



Prototype photo / final appearance may vary

With engineering, manufacturing, assembly and programming all provided by Plast-O-Matic, CAFÉ actuators are available with a wide range of voltage and performance options, as well as mounting and connections for virtually any valve requiring torque up to 20 Nm.

Minimum quantities may apply, depending on level of customization.

# JJD

JJ DOWNS INDUSTRIAL PLASTICS INC.

416.236.1884

[JJDOWNNS.COM](http://JJDOWNNS.COM)

Toronto, ON



## CAFÉ ACTUATOR

### STANDARD CAFE FEATURES

- Multi-Voltage 24-240V AC/DC, 50-60 Hz Input Power with auto-voltage sensing and resettable fuse
- LED status light to indicate operational status of actuator
- Multi-Mode Electronic over-torque protection against valve jam
- Brushless motor with ICP protection
- Thermostatic anti-condensation heater
- Remote position indicator via Programmable relays
- Barrel style visual position indicator
- Weatherproof anti-corrosive and UV protected glass filled polypropylene housing
- Easy mounting with ISO 5211
- All external electrical connections via DIN plugs
- Soft Reset via DIN plugs
- CE marked, IP67 ingress protection
- Plast-O-Matic engineered & assembled in USA

### CAFÉ NITRO FEATURES

- OLED screen
- Over-torque & over-temperature alarms
- (0-20, 4-20) mA or (0-10, 2-10) V DC proportional closed loop control options
- Differential input/output proportional closed loop control options
- Proportional Control Loop with over voltage and overcurrent protection
- Modbus RS485 proportional control option with 13 registers
- Fail-safe option w/battery backup
- Stand alone control option via asynchronous calendar
- Three different drive mode options: Auto, keypad, manual
- Alarm log option
- Run time diagnostic option
- Range of 90° working time from 1 - 30 seconds

## DIMENSIONS

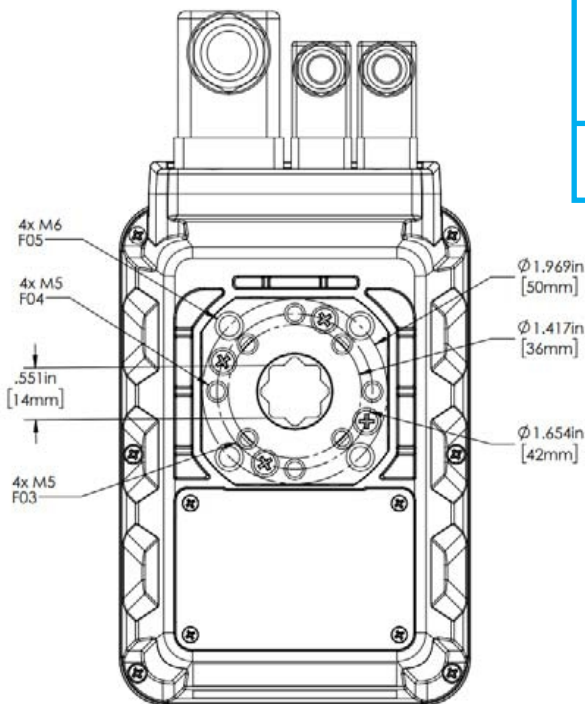
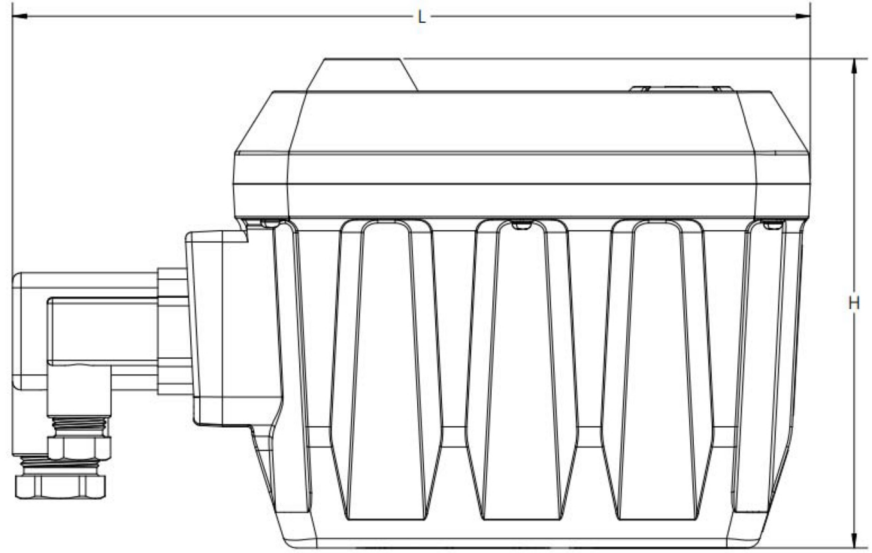
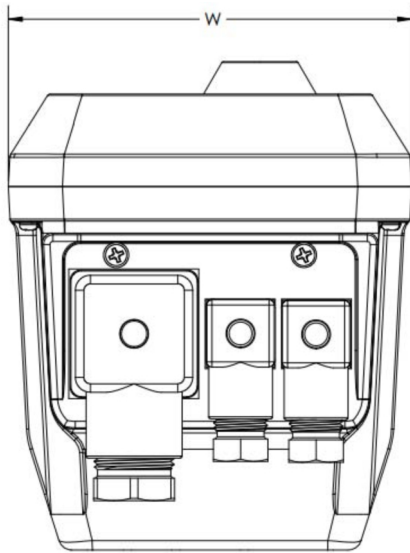

Model	L		W		H	
	IN	MM	IN	MM	IN	MM
CAFÉ	7.40	187.85	3.73	94.62	4.51	114.49

# JJD

JJ DOWNS INDUSTRIAL PLASTICS INC.

416.236.1884

[JJDOWNS.COM](http://JJDOWNS.COM)

Toronto, ON

