

Ball Float Valves

PP

SERIES: BF

SIZES: 1/2" – 1-1/2"

ENDS: Threaded



BF Series Ball Float Valve is a cost effective level control device for water or non-hazardous liquids. The valve may be mounted through a hole in the tank wall and anchored with the lock nut provided.

Features

• For Tank Level Control

All Plastic Construction

- Body components and ball are all plastic construction
- Plastic-coated metal arm for strength and chemical resistance

Easily Maintainable

- Body unscrews from center to expose all internal parts
- Components are all replaceable

Adjustable Float Arm

- No tools needed to adjust the ball
- 5 positions for more accurate level adjustment
- Resolves air gap between liquid level and inlet

Different Bores Available

- Allows for choice in flow rates

Designed for Safety

- Internal plunger seat eliminates fluid escaping from top or rear of arm/pivot
- Threaded outlet into tank for use with standpipe

JJD

JJ DOWNS INDUSTRIAL PLASTICS INC

416.236.1884

JJDOWNS.COM

Toronto, ON



Ball Float Valves

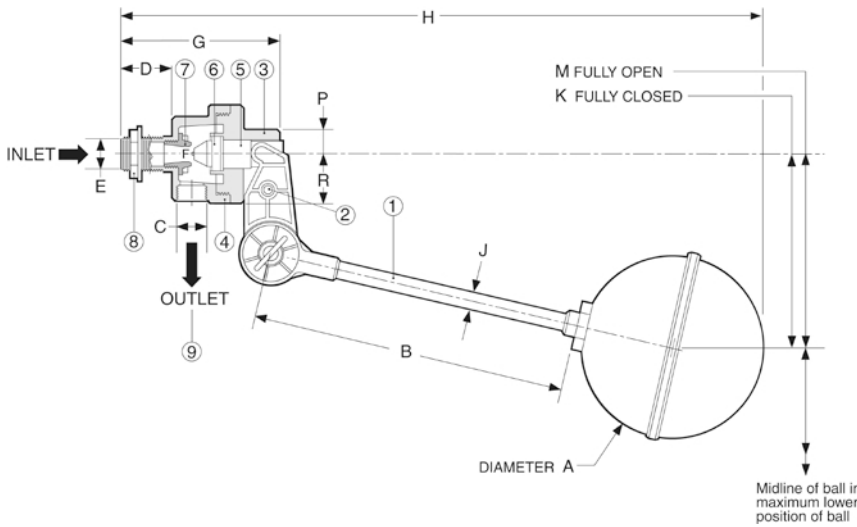

PARTS

▲ Recommended Spare Parts

No.	Part	Pcs.	Materials
1	Float/Arm	1	Polypropylene
2	Screw	1	Polypropylene
3	Body Part "A"	1	Polypropylene
4	Body Part "B"	1	Polypropylene
5	Plunger	1	Polypropylene
6▲	Disc ¹	1	Polyethylene
7▲	Seat	1	Polypropylene
8	Lock Nut	1	Polypropylene
9	Outlet Tube ²	1	Polypropylene

¹ 1", 1-1/2" has PE disc; 1/2" has PP diaphragm

² 3-1/2" long delivery tube is supplied on 1/2" valve outlet only.

TEMPERATURE RANGE

1/2": -20 to 70°C (-4 to 158°F)

1", 1-1/2": -20 to 50°C (-4 to 122°F)

DIMENSIONS INCHES

Size	Type	A	B	C	D	E	Port F	G	H					J
									1	2	3	4	5	
1/2"	Standard	5.0	7.0	3/8" BSP	1.25	1/2" BSP	0.25	2.50	15.75	15.55	15.16	14.37	13.58	0.50
1/2"	High Flow	5.0	7.0	3/8" BSP	1.25	1/2" BSP	0.37	2.50	15.55	15.16	14.37	13.78	12.60	0.50
1"	Standard	7.0	14.5	1" BSP	2.25	1" BSP	0.56	4.37	27.36	26.97	25.59	24.02	21.65	0.75
1"	High Flow	7.0	14.5	1" BSP	2.25	1" BSP	0.81	4.37	27.36	26.77	25.59	23.82	21.46	0.75
1-1/2"	Standard	9.0	15.0	1-1/4" BSP	2.37	1-1/2" BSP	0.87	5.37	31.10	30.71	29.53	28.15	25.79	0.75
1-1/2"	High Flow	9.0	15.0	1-1/4" BSP	2.37	1-1/2" BSP	1.25	5.37	31.10	30.51	29.33	27.56	25.39	0.75

DIMENSIONS INCHES

Size	Type	K Closed					M Open					P	R
		1	2	3	4	5	1	2	3	4	5		
1/2"	Standard	2.36	3.62	5.12	6.89	8.07	8.27	9.65	10.83	12.20	12.99	1.00	1.00
1/2"	High Flow	3.15	5.12	6.38	7.48	8.98	8.27	9.65	10.83	12.20	12.99	1.00	1.00
1"	Standard	5.12	7.87	10.63	13.39	15.75	18.50	20.87	22.83	24.21	25.39	2.01	2.01
1"	High Flow	5.51	8.46	11.42	13.78	16.14	18.50	20.87	22.83	24.21	25.39	2.01	2.01
1-1/2"	Standard	5.12	6.69	10.04	12.80	15.75	21.10	23.03	25.39	27.17	29.53	2.37	2.46
1-1/2"	High Flow	5.51	8.27	12.01	14.76	16.73	21.10	23.03	25.39	27.17	29.53	2.37	2.46

WORKING PRESSURES

FLOW RATES USGPM WATER

Cv VALUES

Size	Type	PSI (Water Level at "K")	vs. Line Pressure – PSI					USGPM at 1 psi ΔP	
			10	30	50	85	100		150
1/2"	Standard	150	2.9	5.0	6.5	8.4	9.1	11.2	0.9
1/2"	High Flow	85	6.5	11.3	14.5	19.0	-	-	2.0
1"	Standard	100	14.1	24.5	31.5	41.2	45.0	-	4.5
1"	High Flow	50	29.5	51.1	65.9	-	-	-	9.3
1-1/2"	Standard	100	22.5	39.0	50.0	65.5	71.0	-	7.0
1-1/2"	High Flow	50	46.4	80.4	103.8	-	-	-	14.6

ORDERING EXAMPLE

Ball Float Valve	BF	B	005	-HF
Body Material	B – PP			
Size	005 – 1/2"	015 – 1-1/2"	010 – 1"	
Flow	Blank – Standard Flow		HF – High Flow	

Example: BF Series Ball Float Valve, PP, 1/2", high flow.

