

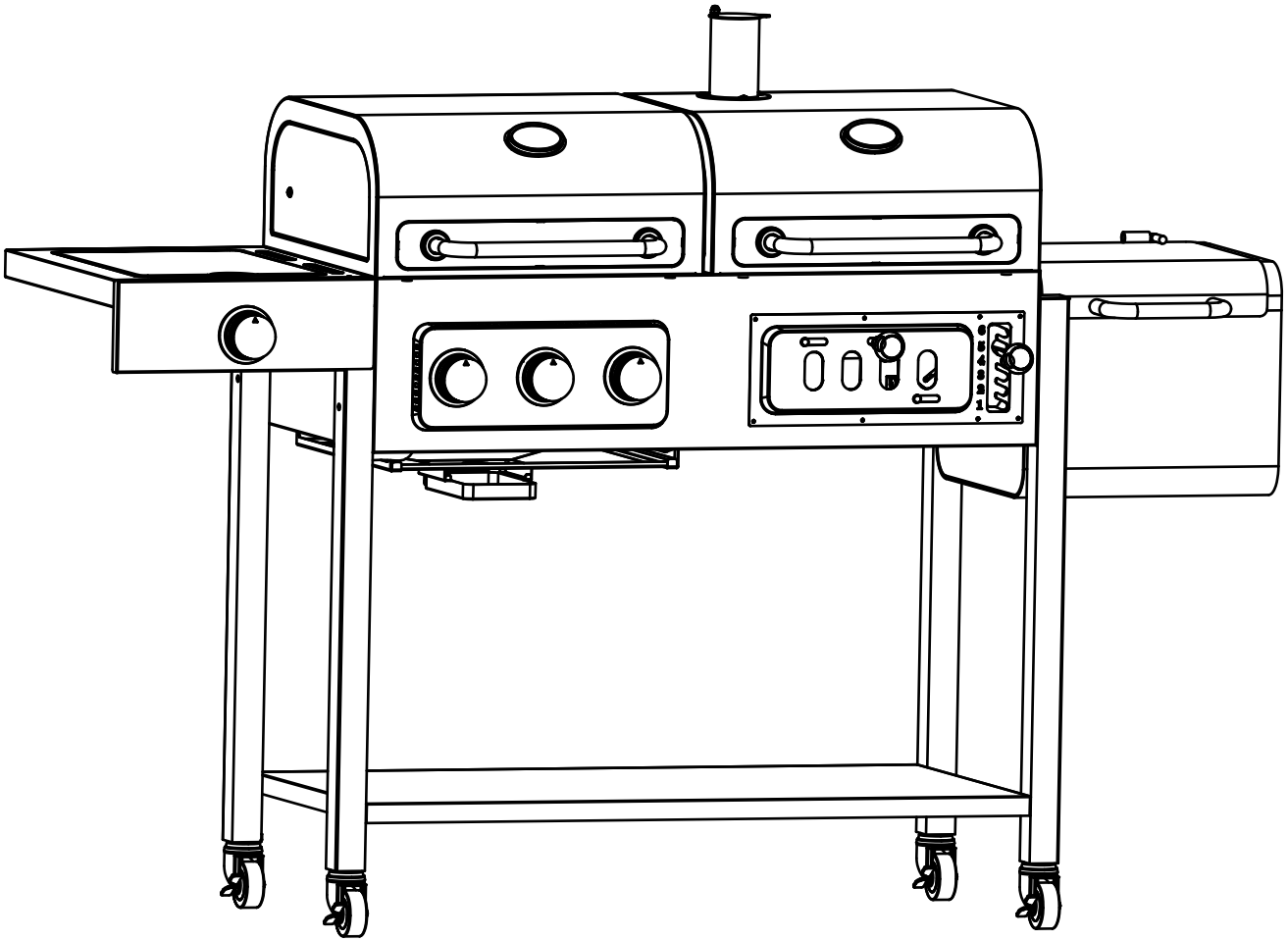

# OWNER'S MANUAL FOR COSMOGRILL 93534

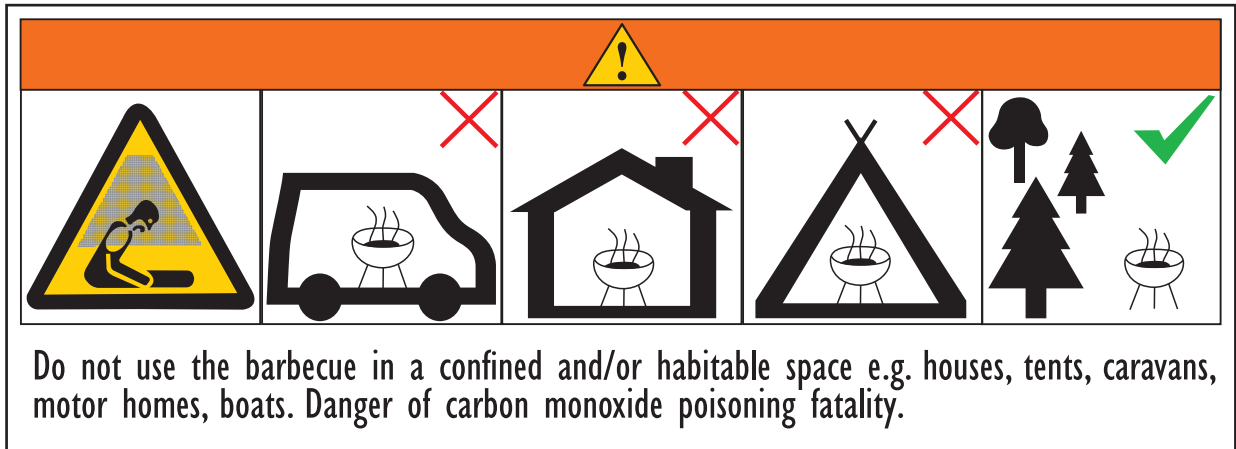

Thank you for purchasing from us! For help with your product please email us on: [Support@cosmogrill.co.uk](mailto:Support@cosmogrill.co.uk)



- For outdoor use only. Not for commercial use.
- Read instructions before using the appliance. Failure to follow instructions could result in death, serious bodily injury, and/or property loss.
- Warning: accessible parts may be very hot. Keep young children away.
- Do not move the appliance during use.
- Any modification of the appliance, misuse, or failure to follow the instructions may be dangerous and will invalidate your warranty. This does not affect your statutory rights.
- Retain these instructions for future reference.

Thank you for purchasing from us! For help with your product please email us on: [Support@cosmogrill.co.uk](mailto:Support@cosmogrill.co.uk)

## Dear customer,

Please take a few minutes before starting operation of the appliance and read the following operating instructions.

Many thanks.

## CONTENTS

SAFETY WARNINGS.....	20
BEFORE FIRST USE .....	22
OPERATION .....	22
COOKING TIPS .....	23
CLEANING AND CARE.....	23
STORAGE AND TRANSPORTATION.....	25
TROUBLESHOOTING .....	25
DISPOSAL .....	26
TECHNICAL DATA .....	26
WARRANTY.....	26

## SAFETY WARNINGS

### GENERAL BARBECUE WARNINGS

1. Assembly time: approx. 45 mins.
2. Retain these instructions for future reference.
3. Use outdoors only.
4. Do not use the barbecue or store gas bottles below ground level. LP gas is heavier than air so if a leak occurs the gas will collect at a low level and could ignite in the presence of a flame or spark.
5. For use with LPG bottled gas only. A suitable regulator must be used for butane, propane or mixes.
6. Remove plastic wrap from any part before lighting.
7. Do not use within 1m of any flammable structure or surface. Do not use under any combustible surface.
8. LP gas cylinders should never be placed directly underneath the barbecue.
9. LP gas cylinders should never be stored or used laid on their side, in the horizontal position. A leak would be very serious and liquid could enter the gas line with serious result.
10. Never store gas bottles indoors.
11. Do not move the appliance during use.
12. Open the barbecue hood before lighting.
13. Do not move the barbecue until it has completely cooled after use.
14. This barbecue must not be left unattended when lit.
15. The hood handle can become very hot. Grip only the centre of the handle. Always use oven gloves when cooking or carrying out any adjustments to the barbecue.
16. Use purpose designed barbecue tools with long and heat resistant handles.
17. Use caution when opening the hood, as hot steam inside is released upon opening.
18. Warning: accessible parts may be very hot. Keep young children away.
19. Turn off the gas supply at the gas cylinder after use.
20. Never cover a barbecue until it has completely cooled.
21. Use this barbecue only on a stable and flat surface.
22. Before use this barbecue, perform a leak test. This is the only safe and sure way to detect any gas leaking from joints and connections of the barbecue after assembly.
23. Leak test annually, and whenever the gas bottle is removed or replaced.
24. Do not store flammable materials near this barbecue.
25. Do not use aerosols near this barbecue.
26. Failure to follow the manual's instructions could result in serious injury or damage.
27. Do not modify the appliance. Modification of this barbecue may be dangerous, is not permitted and will nullify any warranty.
28. This appliance must be kept away from flammable materials during use.
29. All the parts sealed by the manufacturer or his agent shall not be manipulated by the user.
30. If you have any queries regarding these instructions, contact your local dealer.
31. Use Charcoal and a suitable lighting method.
32. **“WARNING! Do not use spirit or petrol for lighting or re-lighting! Use only firelighters complying to EN1860-3!”**



#### ATTENTION!

**This BBQ will become very hot do not move it during operation. Do NOT use indoors.**

**“Warning! Keep children and pets away!”**

**“Caution! Do not use spirit or petrol for lighting or re-lighting! Use only firelighters complying to EN 1860-3”**

### FLARE-UP CONTROL \*VERY IMPORTANT NOTICE\*

Flare-ups occur when meat is barbecued, and its fat and juices fall upon the hot flame tamer. Smoke of course helps give food its barbecued flavour, but it is best to avoid excessive flare-up to prevent food being burned. To control flare-ups, it is ABSOLUTELY ESSENTIAL to trim away excess fat from meat and poultry before grilling, use cooking sauces and marinades sparingly and try to avoid very cheap cuts of meat or meat products as these tend to have a high fat and water content. Also, the burners should always be placed on the low setting during cooking.



Thank you for purchasing from us! For help with your product please email us on: [Support@cosmogrill.co.uk](mailto:Support@cosmogrill.co.uk)

When flare-ups do occur, they can usually be extinguished by applying baking soda or salt directly onto the flame tamer. Always protect your hands when handling anything near the cooking surface of the barbecue and take care to protect yourself from the flames. If a fat fire occurs, please see the instructions given below.

### FAT FIRES

Empty and clean the drip tray, of food debris after each cooking session. If the barbecue is to be used for large gatherings, it will be necessary to turn off and cool the barbecue every two hours to remove food debris from the drip tray, and clean it out. The time between cleaning may need to be reduced if very fatty foods or cheap meat products are being cooked. Failure to do this may result in a fat fire, which may cause injury and could seriously damage the barbecue.

### CARBON MONOXIDE HAZARD

 <b>WARNING</b>	<b>CARBON MONOXIDE HAZARD</b> Danger of carbon monoxide poisoning-NEVER light this product or let it smoulder or cool down in confined spaces
	

### IN THE EVENT OF A FAT FIRE:

- If safe to do so, turn all control knobs to the 'off' position.
- Turn off the gas supply at the gas bottle.
- Keep everyone at a safe distance from the barbecue and wait until the fire has burnt out.
- Do not close the hood or lid of the barbecue.
- NEVER DOUSE A BARBECUE WITH WATER. IF AN EXTINGUISHER IS USED, IT SHOULD BE A POWDER TYPE.
- DO NOT REMOVE THE DRIP TRAY.
- If the fire does not seem to be abating or appears to be worsening, contact your local Fire Brigade for assistance.

### GAS CONNECTIONS / GAS CYLINDER / PRESSURE REGULATOR WARNINGS

This barbecue can use either propane or butane or propane/ butane mixed LPG (liquid petroleum gas) bottled gas. Propane bottles, will supply gas all year round, even on cold winter days. Butane bottles will supply sufficient gas in summer, but it may affect the performance of the barbecue and restrict the heat output available from the burners, particularly once the gas temperature starts to fall below +10 °C. A spanner may be required to change gas bottles.

1. The hose should hang freely with no bends, twisting, tension, folds, or kinks that could obstruct free flow of gas. Always inspect the hose for cuts, cracks, or excessive wear before use.
2. Apart from the connection point, no part of the hose should touch any hot barbecue parts. If the hose shows any sign of damage it must be replaced with a hose suitable for use with LP gas which meets the national standards for the country of use.
3. A suitable hose must comply with EN16436-1, and the length should not exceed 1.5 metres.

For optimal performance, we suggest to use a 5-15kg gas bottle. The maximum dimension of the gas bottle is dia 31.5cm and height 58 cm.

1



Key

1= maximum diameter

2= maximum height

Never mount the gas bottle under the barbecue on the base shelf as this could result in serious injury to the user, other people and/or property. **Always place the gas bottle at the side of the appliance. The gas bottle should be sited as far away from the appliance as possible without straining the hose.** This appliance is only suitable for use with low-pressure butane or propane gas and fitted with the appropriate low-pressure regulator via a flexible hose. The hose should be secured to the regulator and the appliance with hose clips/nut. Use a suitable regulator certified to EN16129. Please consult your LPG dealer for information regarding a suitable regulator for the gas cylinder.

Thank you for purchasing from us! For help with your product please email us on: [Support@cosmogrill.co.uk](mailto:Support@cosmogrill.co.uk)



## **BEFORE FIRST USE**

### **CHOOSING A LOCATION**

This barbecue is for outdoor use only and should be placed in a well-ventilated area, and on a safe and even surface. Never place your barbecue below ground level. Take care to **ensure that the barbecue must be used on incombustible floor**. The sides of the barbecue should NEVER be closer than 1 metre from any combustible surface, including trees and fences and make sure that there are no heat sources near the barbecue (cigarettes, open flames, spark etc.). Keep this barbecue away from any flammable materials!

### **PRECAUTIONS**

Do not obstruct any ventilation openings in the barbecue body. Position the gas bottle on level ground next to the barbecue and safely away from any source of heat. Should you need to install or change the gas bottle, confirm that the barbecue is switched off, and that there are no sources of ignition (cigarettes, open flame, sparks, etc.) near before proceeding.

### **GAS CONNECTIONS**

Confirm all barbecue control knobs are in the off position. Connect the regulator to the gas bottle according to your regulator and bottle dealer's instructions.

### **TESTING FOR GAS LEAKS**

Confirm all control knobs are in the off position. Turn the gas on / open the gas control valve on the gas bottle or regulator. Check for leaks by brushing a solution of ½ water and ½ liquid detergent / soap over all the gas system joints, including gas bottle valve connections, hose connections, and regulator connections. NEVER USE AN OPEN FLAME to test for leaks at any time. If bubbles form over any of the joints there is a leak. Turn off the gas supply at the gas bottle. Retighten all joints. Repeat test. If bubbles form again do not use the barbecue and contact your local distributor for assistance. Always wipe the mixed solution (½ water and ½ liquid detergent / soap) from all joints and connections after leak testing.

## **OPERATION**

### **WARNING**

1. Before proceeding, make certain that you understand the IMPORTANT INFORMATION section of this manual.
2. Your barbecue is not designed to be used with more than 50% of the cooking area as a solid plate — this includes baking dishes. Full coverage will cause excessive build-up of heat and damage the barbecue. This is not covered by warranty.

### **COOKING TIPS**

To prevent foods from sticking to the cooking surface, please use a long handled brush to apply a light coat of cooking or vegetable oil before each barbecuing session. (Note: When cooking for the first time, paint colours may change slightly as a result. This is normal and should be expected.) During use, the protective coating may come off the cooking surface. This is normal and is not harmful. Line the drip pan with aluminium foil. This will make cleanup easy.

### **IGNITING THE GRILL / SIDE BURNER(S)**

#### **IGNITING THE MAIN BURNER(S)**

1. Read the operating instructions first before using the appliance.
2. The lid must be open before lighting the burner.
3. Set all control knobs to "Off" position.
4. Open the gas bottle valve according to operating instruction.
5. Push in and turn the sign burner control knob anti-clockwise until it reaches the ignition sign and a click sound is heard. Then, the burner is lit.
6. After the burner is lit, push in and turn the left and right burners in the sequence stated.
7. Always light the sign burner first, before the next burner on the left or the right.
8. If the burner does not light, turn all control knobs to "Off" position. Then, repeat the lighting procedure after 5 minutes.

#### **IGNITING THE SIDE BURNER**

1. Set all control knobs to "Off" position.
2. Open the gas bottle valve according to operating instruction.
3. Push in and turn the side burner control knob anti-clockwise until it reaches the ignition sign and a click sound is heard. Then, the burner is lit.
4. If the side burner does not light, turn side control knob to "Off" position. Then, repeat the lighting procedure after 5 minutes.

---

Thank you for purchasing from us! For help with your product please email us on: [Support@cosmogrill.co.uk](mailto:Support@cosmogrill.co.uk)

## IGNITING THE CHARCOAL BARBECUE

### Method 1. Charcoal & Lighting Fluid/ Gel

1. Set up your Charcoal BBQ in a safe place. Place enough charcoal in the charcoal grate to a depth of 3 - 5 cm.
2. Taking care not to spill any liquid/ gel onto your hands or clothes. Apply carefully the lighting fluid/ gel over the charcoal.
3. If using lighting fluid, wait for 30 seconds to allow the liquid to soak into the charcoal.
4. Do not light the charcoal if you have spilt fluid or gel onto your clothes. Light the charcoal using a long taper or safety lighter. The charcoal will then burn for a period with flames.
5. When the flames die down, check the charcoal is beginning to glow red. If your coals are going out, you should open all the vents and allow to cool down before trying to apply more liquid.  
**CAUTION: Apply carefully lighting fluid/ gel in small amounts. Over application can be dangerous.**
6. Do NOT squirt liquid onto burning charcoal.
7. After lighting, the fire should be ready for cooking in 30-40 minutes, or when even grey ash is visible by day, or an even red glow is visible by night.

### Method 2. Lighting Blocks

1. Place three or four Lighting Blocks in the centre of the Charcoal grate and light with a match.
2. Place pieces of charcoal around each burning block. Add more charcoal as required, in a pyramid formation.
3. When burning is established, spread the fuel out evenly. After lighting, the fire should be ready, or when even grey ash is visible by day, or an even red glow is visible by night.
4. Make sure that the cooking grill is fully located into the grill supports so that the cross bar supports lock behind the retaining edges.
5. When the charcoal is alight, the smoke and flames have died down and the charcoal has an even layer of grey ash, rake the charcoal into a level layer in the hearth.
6. Small quantities of charcoal may be added on top of the charcoal layer prior to cooking to extend cooking time.
7. To help prevent food sticking, apply a tin coating of cooking oil on the grill prior to cooking.
8. To adjust the airflow using the air vent we recommend to use of a heat resistant glove.
9. ALWAYS WEAR OVEN GLOVES WHEN HANDLING THE CHARCOAL BBQ.
10. Recommend using Maximum 1.5kg of charcoal briquettes on the charcoal grate. Excess charcoal will make the BBQ too hot for cooking.
11. Ensure the barbecue has cooled down completely before removing the charcoal ash.
12. To make it easier to clean your Charcoal BBQ after use, line the firebowl with aluminium cooking foil, shiny side up. Remember to leave ventilation holes clear by piercing the foil where necessary. This process will lengthen the life of your Charcoal BBQ.
13. Charcoal is available in lump wood from (large irregular pieces) and as briquettes (uniformly sized pieces).

## COOKING TIPS

- Thoroughly defrost frozen meat and poultry in the refrigerator before cooking. Keep raw meat and poultry separate from cooked food.
- Ensure that the grill is thoroughly cleaned before cooking and lighting the barbecue.
- Always wash hands after handling raw meat and poultry before handling any ready to eat food.
- Wipe and disinfect surfaces that have been in contact with raw meat and poultry.
- When barbecuing meat and poultry, make sure the barbecue is really hot. Place the larger, thicker portions furthest away from the most intense heat to ensure thorough cooking without burning and turn regularly.
- Use separate utensils for handling raw meat or poultry and cooked food on the barbecue, or wash them thoroughly between use.
- To check whether meat, particularly poultry, is cooked, pierce the flesh with a skewer or fork: the juices should run clear. Ensure the product is piping hot throughout.

## GRILL COOKING

The burners heat up the flame tamer underneath the grill, which in turn heats the food on the grill. The natural food juices produced during cooking fall onto the hot flame tamer below and vaporise. The subsequent rising smoke bastes the food, as it travels upwards, imparting that unique barbecued flavor.

## ROASTING HOOD COOKING

Barbecues equipped with a roasting hood give the option to form an 'oven' for roasting or baking food, such as joints of meat or whole chickens, etc. More even cooking of food will actually be achieved by using the barbecue with the hood down. However, this should only be done with the burners on low.

For best results, place the food you wish to bake or roast on a metal baking tray and set it on one side of the cooking grill.

Turn the burner directly under the food to the OFF position and turn all other burners to a LOW to MEDIUM position.

Close the hood to cook the food 'indirectly'. Avoid lifting the hood unnecessarily as heat is lost every time the hood is opened. If the hood is opened during cooking please allow extra time for the barbecue to regain its temperature and complete the cooking. Use the temperature gauge (if applicable) to monitor the heat of the barbecue.

If the internal heat becomes too high, turn the burners down to the low position. It is not necessary or advisable to have all of the burners on high when the hood is closed.

DO NOT ALLOW YOUR BARBECUE TO OVERHEAT. Take care when opening the hood as hot steam can be released on opening.

## WARMING RACK

Warming racks are a convenient way to keep cooked food warm or to warm items such as bread rolls. It is advisable to place food (particularly fatty foods) to the front of the warming rack to avoid the possibility of juices and fat running down the back of your barbecue. Always check that your warming rack is properly fitted before use.

## CLEANING AND CARE

Please use the charcoal complying to EN1860-2.

- It is not advisable to completely fill the firebowl as the BBQ may become far too hot to cook successfully. As a guide, a 3kg bag of charcoal briquettes should last for at least 2 full BBQ fires.
- If the fires flares up due to dripping fat then douse the flames lightly with a fine water spray.
- When you have finished using the Charcoal BBQ, never pour cold water directly on the coals to extinguish them as this may damage your Charcoal BBQ. Use old cinder, sand or a fine water spray.

Thank you for purchasing from us! For help with your product please email us on: [Support@cosmogrill.co.uk](mailto:Support@cosmogrill.co.uk)

- Empty the bottom bowl of ashes when they are completely cold.
- To clean your Charcoal BBQ, soak the cooking grill and tools in hot soapy water as soon as possible after use. Dry thoroughly and store in a dry place. Do not leave your Charcoal BBQ outside unprotected.

1. the barbecue has to be installed on a secure level base prior to use
2. the barbecue shall be heated up and the fuel kept red hot for at least 30 min prior to the first cooking
3. do not cook before the fuel has a coating of ash

## END OF COOKING SESSION

After each cooking session, turn the barbecue burners to the “high” position and burn for 5 minutes. This procedure will burn off cooking residue, thus making cleaning easier. Make sure the hood is open during this process.

## TURNING OFF YOUR BARBECUE

When you have finished using your barbecue, turn all the control valves fully clockwise to the “Off” position, then switch off the gas supply at the bottle. Wait until the barbecue is sufficiently cool before closing the hood or lid.

Regularly clean your barbecue between uses and especially after extended periods of storage. Ensure the barbecue and its components are sufficiently cool before cleaning. Do not leave the barbecue exposed to outside weather conditions or stored in damp, moist areas.

- Never douse the barbecue with water when its surfaces are hot.
- Never handle hot parts with unprotected hands.

In order to extend the life and maintain the condition of your barbecue, we strongly recommend that the unit be covered when left outside for any length of time, especially during the winter months.

Even when your barbecue is covered for its protection, it must be inspected on a regular basis as damp or condensation can form which may result in damage to the barbecue. It may be necessary to dry the barbecue and the inside of the cover. It is possible for mould to grow on any fat remaining on parts of the barbecue. This should be cleaned off smooth surfaces with hot soapy water.

Any rust that is found that does not come into contact with the food should be treated with a rust inhibitor and painted with barbecue paint or a heat resistant paint. A chrome cleaner may be used on chrome parts if required. To prevent rusting, wipe chrome plated parts with cooking oil after rinsing and drying.

In order to extend the life and maintain the condition of your barbecue, we strongly recommend that the unit be covered when left outside for any length of time, especially during the winter months.

Even when your barbecue is covered for its protection, it must be inspected on a regular basis as damp or condensation can form which may result in damage to the barbecue. It may be necessary to dry the barbecue and the inside of the cover. It is possible for mould to grow on any fat remaining on parts of the barbecue. This should be cleaned off smooth surfaces with hot soapy water.

Any rust that is found that does not come into contact with the food should be treated with a rust inhibitor and painted with barbecue paint or a heat resistant paint. A chrome cleaner may be used on chrome parts if required. To prevent rusting, wipe chrome plated parts with cooking oil after rinsing and drying.

## COOKING SURFACES & WARMING RACK

When the barbecue has cooled, clean with hot soapy water. To remove any food residue, use a mild cream cleaner on a non-abrasive pad. Do not use scouring pads or powders as they can permanently damage the finish. Rinse well and dry thoroughly. Due to the weight of the cooking surfaces, we do not recommend cleaning in a dishwasher.

It is quite normal for surface rust to be present on the cooking surface. If rust appears between uses or in storage, clean with a soft brass wire brush. Be careful not to damage the cooking surface, re-oil and cure.

## BURNER

Provided that they are operating correctly, in normal usage, burning off the residue after cooking will keep the burners clean.

The burners should be removed and cleaned annually, or whenever heavy build-up is found, to ensure that there are no signs of blockage (debris, insects) in either the burner portholes or the primary air inlet of the burners. Use a pipe cleaner to clear obstructions.

When refitting the burners, be careful to check that the neck of the burner fits over the valve outlet. It is quite normal for surface rust to be present on the burners. If rust appears between uses or in storage, clean with a soft brass wire brush.

## FLAME TAMER

Remove any food residue from the flame tamer surface with a plastic or wooden scraper or brass wire brush.

Do not use a steel scraper or wire brush. Clean with hot soapy water and rinse well.

## DRIP TRAY

After every use, empty and clean the drip tray of any fat or food particles, using a plastic or wooden scraper if necessary.

Failure to keep it clean, and excessive build up can result in a fat fire. This can be hazardous and severely damage the barbecue. This is not a fault in the barbecue and is therefore not covered by the terms of the warranty. If required, the tray can be washed in hot soapy water.

## BARBECUE BODY

Regularly remove excess grease or fat from the barbecue body using a cloth wrung out in hot soapy water and dry thoroughly. Excess fat and food debris can be removed from inside the body using a soft plastic or wooden scraper. It is not necessary to remove all the grease from the body. If you need to clean fully, use hot soapy water and a cloth, or nylon-bristled brush only. Do not use abrasives. Remove cooking surfaces and burners before full cleaning. Do not immerse the gas controls or manifold in water. Check burner operation after carefully refitting into body.

A stainless steel cleaner may be used on stainless steel parts if required.

Whenever a barbecue is being assembled for the first time or its burners are being cleaned, make sure each gas valve tip goes into the burner venturi tube completely during the assemble or re-assemble process.

Thank you for purchasing from us! For help with your product please email us on: [Support@cosmogrill.co.uk](mailto:Support@cosmogrill.co.uk)

## BARBECUE HOOD OR LID

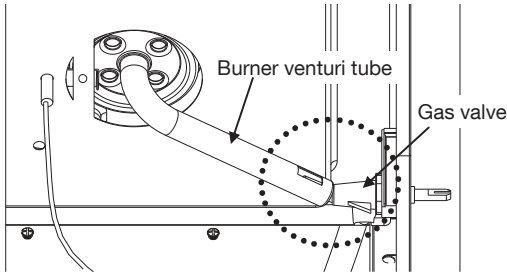

Use a non-abrasive cloth or pad and clean with hot, soapy water. Do not use scouring pads or powders as they can permanently damage the finish.

## TROLLEY

Wipe with a cloth wrung out in hot soapy water and dry.

## FIXINGS

All screws and bolts, etc. should be checked and tightened on a regular basis.

## STORAGE AND TRANSPORTATION

Ensure the barbecue is properly cooled before covering or storing. Store your barbecue in a cool dry place. It must be inspected on a regular basis as damp or condensation can form which may result in damage to the barbecue. It may be necessary to dry the barbecue and the inside of the cover if used.

Mould can grow under these conditions and should be cleaned and treated if required. Any rust that is found that does not come into contact with the food should be treated with a rust inhibitor and painted with barbecue paint or a heat resistant paint.

Warming racks and cooking grills should be coated with cooking oil.

Cover the burners with aluminum foil in order to prevent insects or other debris from obstructing the burner holes.

If the barbecue is to be stored indoors, the gas bottle must be disconnected and left outside. The gas bottle should always be stored outside, in a dry, well-ventilated area, away from any sources of heat or ignition.

Do not let children tamper with the bottle.

When using the barbecue after extended periods of storage follow the cleaning procedures.

## TRANSPORTATION

1. Switch the appliance off and remove the batteries.
2. Attach transportation guards, if applicable.
3. Always push or pull the appliance by its handle / gripping surfaces.
4. Protect the appliance from any heavy impact or strong vibrations which may occur during transportation in vehicles.
5. Secure the appliance to prevent it from slipping or falling over.

## TROUBLESHOOTING

Problem	Possible Cause	Solution
Burner will not light using the ignition system	<ul style="list-style-type: none"> <li>• LP gas cylinder is empty</li> <li>• Faulty regulator</li> <li>• Obstructions in burner</li> <li>• Obstructions in gas jets or gas hose</li> <li>• Electrode wire is loose or disconnected on elec-trode or ignition unit.</li> <li>• Electrode or wire is damaged</li> <li>• Faulty pushbutton ignitor</li> </ul>	<ul style="list-style-type: none"> <li>• Replace with full cylinder</li> <li>• Have regulator checked or replace</li> <li>• Clean burner</li> <li>• Clean jets and gas hose</li> <li>• Reconnect wire</li> <li>• Change electrode and wire</li> <li>• Change ignitor</li> </ul>
Burner will not light with a match	<ul style="list-style-type: none"> <li>• LP gas cylinder is empty</li> <li>• Faulty regulator</li> <li>• Obstructions in burner</li> <li>• Obstructions in gas jets or gas hose</li> </ul>	<ul style="list-style-type: none"> <li>• Replace with full cylinder</li> <li>• Have regulator checked or replace</li> <li>• Clean burner</li> <li>• Clean jets and gas hose</li> </ul>
Low flame or flashback (fire in burner tube— a hissing or roaring noise may be heard)	<ul style="list-style-type: none"> <li>• LP gas cylinder too small</li> <li>• Obstructions in burner</li> <li>• Obstructions in gas jets or gas hose</li> <li>• Windy conditions.</li> </ul>	<ul style="list-style-type: none"> <li>• Use larger cylinder.</li> <li>• Clean burner</li> <li>• Clean jets and gas hose</li> <li>• Use BBQ in a more sheltered position</li> </ul>
Gas valve knob difficult to turn	<ul style="list-style-type: none"> <li>• Gas valve jammed</li> </ul>	<ul style="list-style-type: none"> <li>• Replace gas valve</li> </ul>

Thank you for purchasing from us! For help with your product please email us on: [Support@cosmogrill.co.uk](mailto:Support@cosmogrill.co.uk)

## DISPOSAL



### Environmental Protection

Discarded electric appliances are recyclable and should not be discarded in the domestic waste! Please actively support us in conserving resources and protecting the environment by returning this appliance to the collection centres.



Do not put your used batteries, nickel cadmium, rechargeable, round cell or starter batteries in with your household rubbish. Take them to an appropriate disposal/collection site.

Pb Cd Hg

## TECHNICAL DATA

<b>Model Number</b>	KS203500S				
<b>Pin Number</b>	0359BU1015				
<b>Gas Category</b>	I <sub>3+(28-30/37)</sub>		I <sub>3 B/P (30)</sub>	I <sub>3 B/P (37)</sub>	I <sub>3 B/P (50)</sub>
<b>Gas Pressure</b>	28 - 30 mbar	37 mbar	30 mbar	37 mbar	50 mbar
<b>Injector Size</b>	0.71 mm	0.71 mm	0.71 mm	0.66 mm	0.62 mm
<b>Injector Size (Side burner)</b>	0.89 mm	0.89 mm	0.89 mm	0.84 mm	0.79 mm
<b>Gas Type</b>	Butane	Propane	Butane/Propane / LPG	Butane/Propane / LPG	Butane/Propane / LPG
<b>Total Burner Heat Input</b>	9.35 KW				
<b>3 Burner Heat Input</b>	2.05 KW*3				
<b>Side burner Heat Input</b>	3.2 KW				
<b>Total Gas Consumption</b>	682 g/h				
<b>Country of Destination</b>	I <sub>3+(28-30/37)</sub> for BE, CH, CY, CZ, ES, FR, GB, GR, IE, IT, LV, LT, LU, PT, SK, SI.				
	I <sub>3B/P(30)</sub> for CY, DK, EE, FI, FR, HU, IT, NL, NO, SE, SI, SK, RO, HR, BG, IS, LU, MT.				
	I <sub>3B/P(37)</sub> for PL				
	I <sub>3B/P(50)</sub> for AT, SK, CH, DE, CZ				

## WARRANTY

A statutory warranty applies for this product.

Damages caused by wrong treatment or operation, by false placement or storage, improper connection or installation, as well as force or other external influences are not covered by this warranty. We recommend careful reading of the operating instructions as it contains important information.

### Note:

- In case this product does not function correctly, please firstly check if there are other reasons, e.g. for electrical appliances interruption of the power supply, or generally incorrect handling are the cause.
- Please note that, where possible, the following documents or rather information should be provided together with your faulty product:
  - Purchase receipt
  - Model description/Type/Brand
  - Describe the fault and problem as detailed as possible

Thank you for purchasing from us! For help with your product please email us on: [Support@cosmogrill.co.uk](mailto:Support@cosmogrill.co.uk)

# BEWARE

# CARBON MONOXIDE KILLS

## WHAT IS CARBON MONOXIDE?

Carbon Monoxide (CO) is produced when a fuel such as charcoal, gas or petrol burns incompletely. This could be because an appliance isn't working properly or might simply happen as part of its normal function. Barbecues, for example, produce Carbon Monoxide even when they are working well.

Carbon Monoxide is colourless, odourless and poisonous. In high concentrations it can kill swiftly. In smaller concentrations CO poisoning can give symptoms similar to flu or food poisoning. Look out for headaches, nausea and vomiting, dizziness, drowsiness and weakness - but the best advice is to avoid any chance of being poisoned in the first place.

## SAFETY ADVICE

- Never take a barbecue into an enclosed area, including tents, EVEN IF YOU THINK IT'S COOLED DOWN. A warm, smouldering barbecue gives off plenty of poisonous Carbon Monoxide (CO), which can kill.
- Never use a fuel-burning appliance to heat an enclosed area. Gas and kerosene heaters should only be used outside. Stoves and barbecues are designed for cooking not space heating.
- Never run a gas, petrol or diesel-powered generator within an enclosed area.
- Don't cook inside an enclosed area, unless there's an area specifically designed for this purpose and that provides adequate ventilation.
- Always have gas appliances serviced regularly.
- You cannot smell, taste or detect Carbon Monoxide but it can kill quickly and without warning. Symptoms are similar to flu or food poisoning. Look out for HEADACHES, NAUSEA, VOMITING, DIZZINESS, DROWSINESS and WEAKNESS.

For more information visit [nhs.uk/carbonmonoxide](https://nhs.uk/carbonmonoxide)

Thank you for purchasing from us! For help with your product please email us on: [Support@cosmogrill.co.uk](mailto:Support@cosmogrill.co.uk)

# Parts Diagram

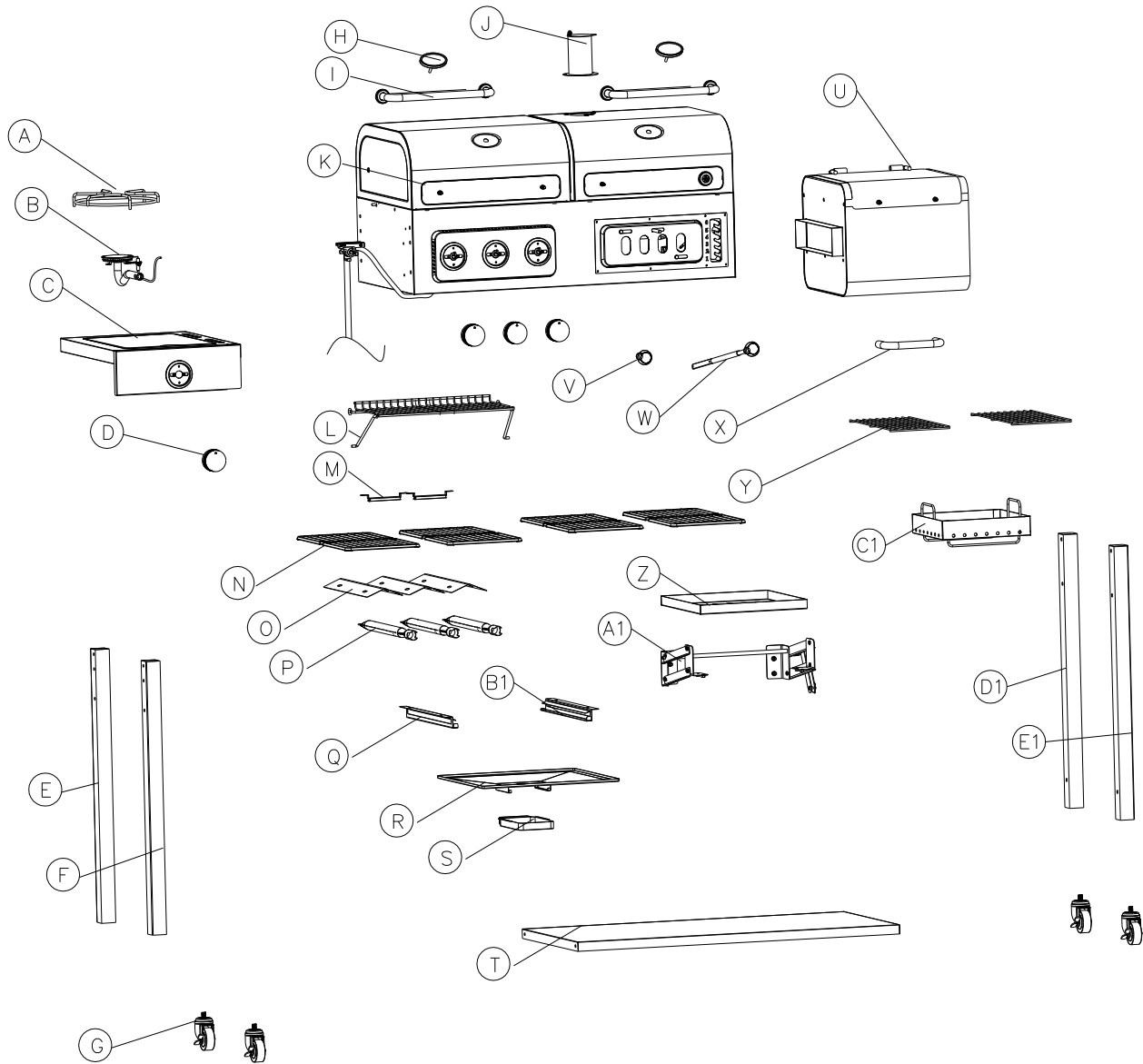

## Parts List

Quantities vary according to model purchased. Specifications subject to change without prior notice. For more details on hardware, please see the corresponding Hardware Reference Diagram for your barbecue model.

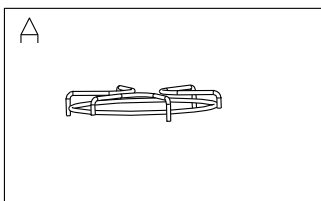

1X

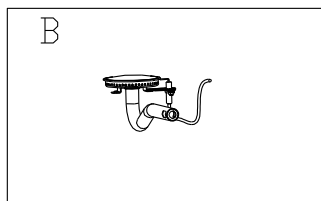

1X

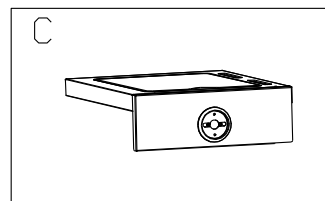

1X

Thank you for purchasing from us! For help with your product please email us on: [Support@cosmogrill.co.uk](mailto:Support@cosmogrill.co.uk)

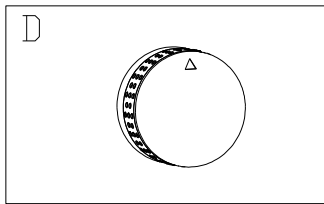

4X

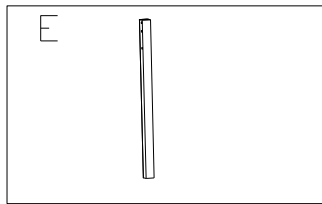

1X

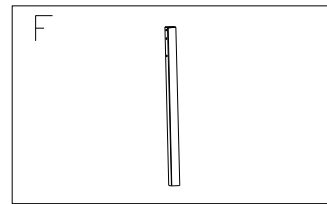

1X

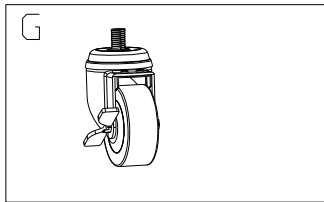

4X

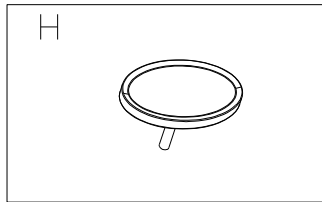

2X

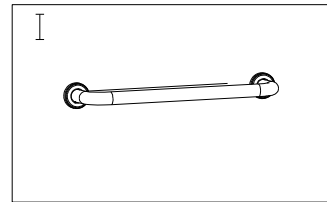

2X

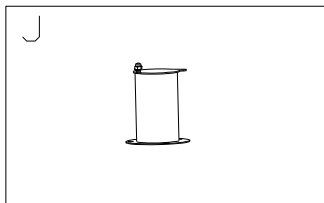

1X

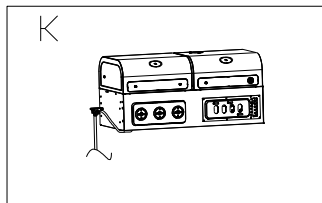

1X

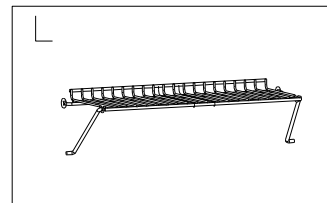

1X

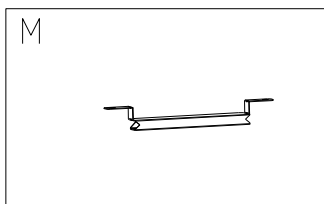

2X

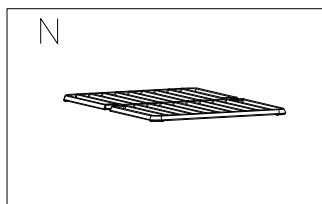

4X

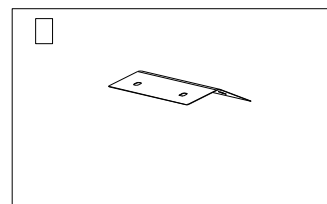

3X

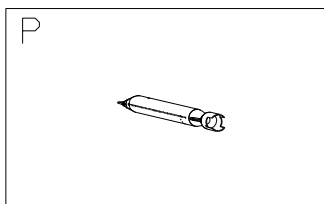

3X

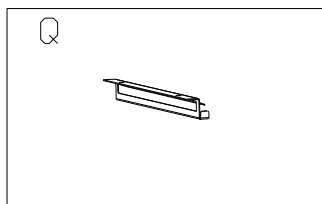

1X

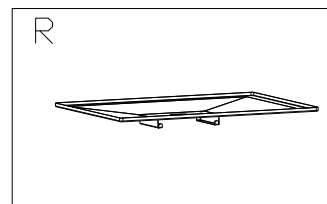

1X

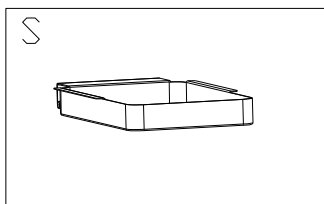

1X

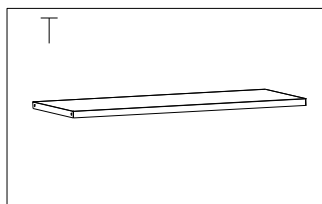

1X

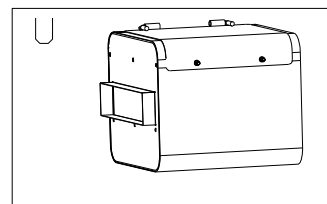

1X

Thank you for purchasing from us! For help with your product please email us on: [Support@cosmogrill.co.uk](mailto:Support@cosmogrill.co.uk)



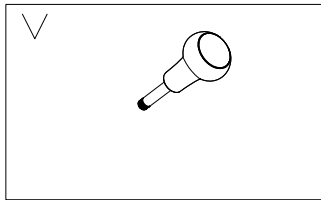

1X

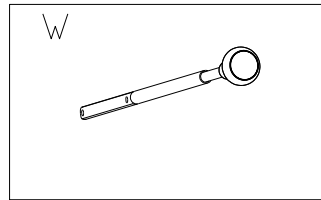

1X

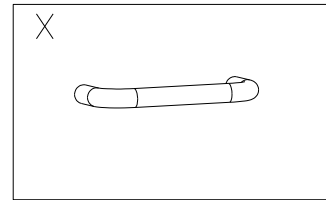

1X

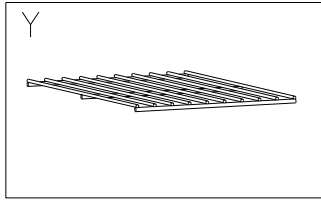

2X

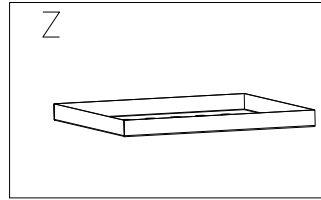

1X

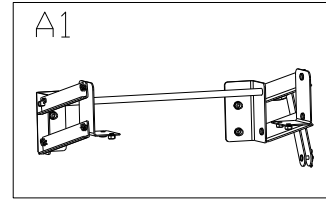

1X

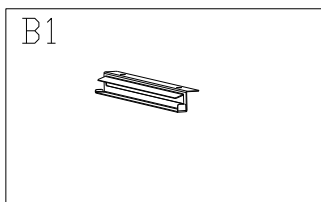

1X

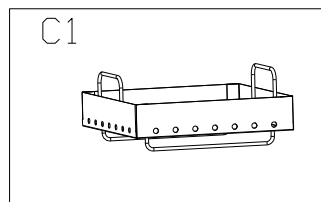

1X

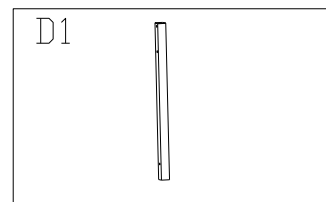

1X

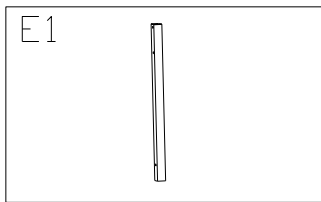

1X

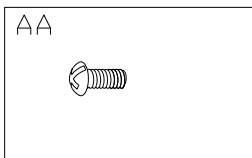

37X M6X15

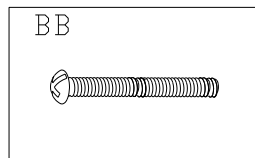

6X M6X55

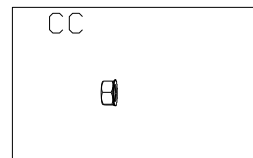

13X M6 KEPS Nut

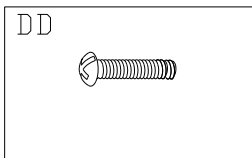

2X M6X35

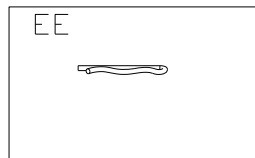

2X R Clips

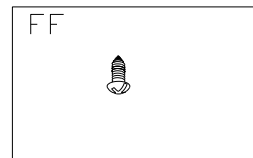

6X M4X10

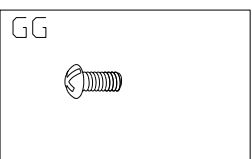

4X M4X8

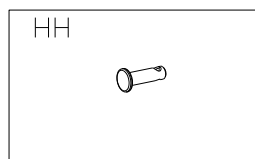

2X Hinge Pin x2

Thank you for purchasing from us! For help with your product please email us on: [Support@cosmogrill.co.uk](mailto:Support@cosmogrill.co.uk)

## ***TOOLS NEEDED FOR ASSEMBLY:***

- Medium size flat blade or Philips/cross-point screwdriver
- Adjustable spanner or metric spanner set

This barbecue requires two people for assembly. Please remove all packaging materials from all individual parts before assembling. Please lay out all nuts and bolts and check lengths before assembling. Whilst every care is taken during the manufacture of this product, care must be taken during the assembly in case sharp edges are present.

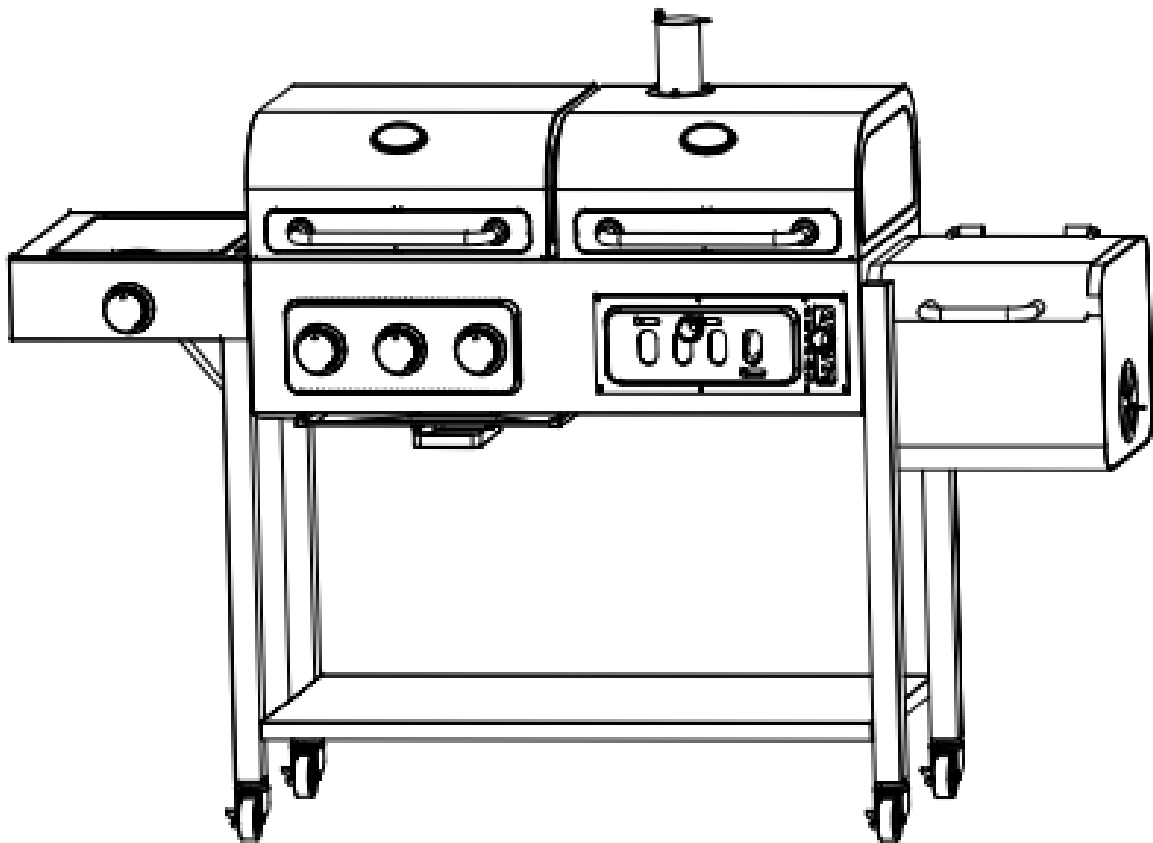

Thank you for purchasing from us! For help with your product please email us on: [Support@cosmogrill.co.uk](mailto:Support@cosmogrill.co.uk)

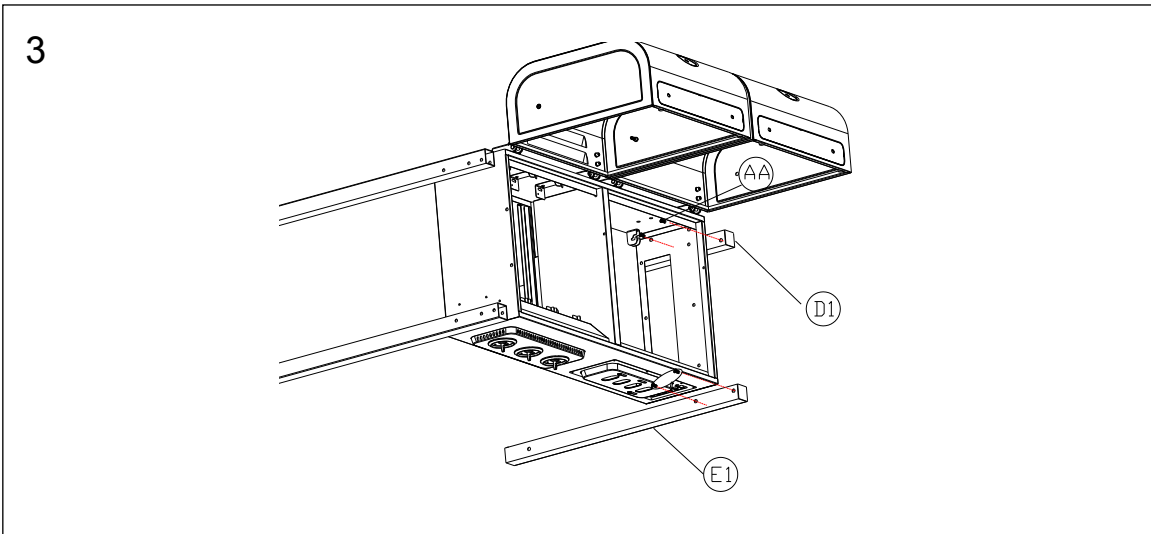
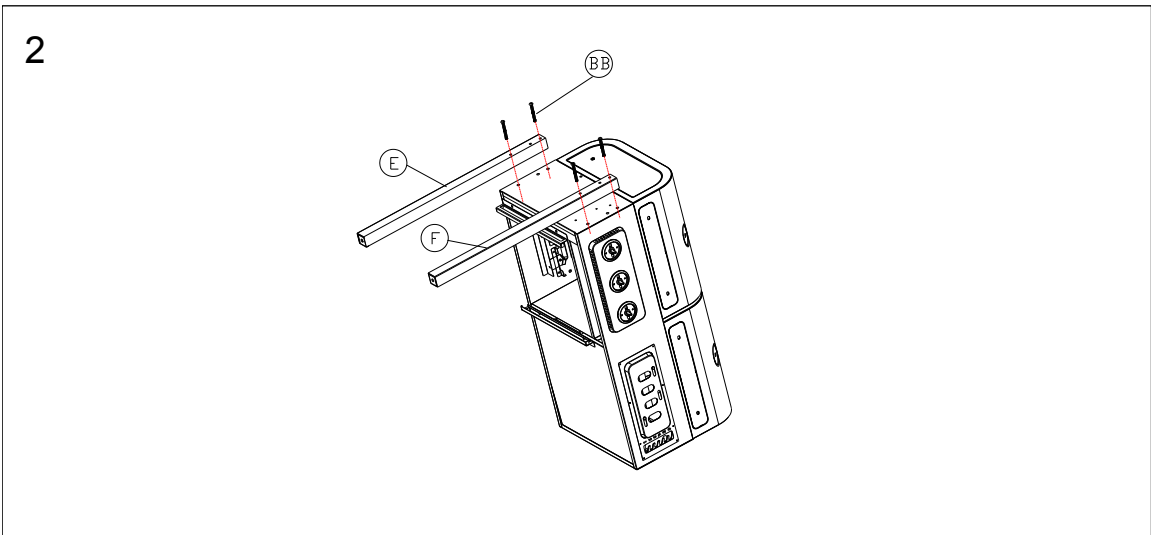
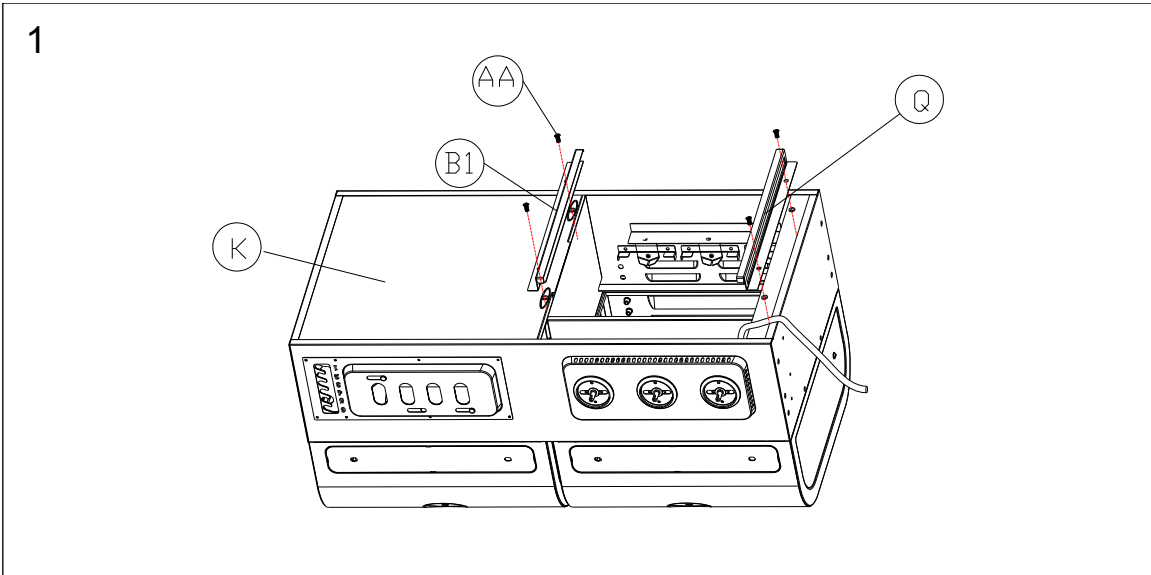

Thank you for purchasing from us! For help with your product please email us on: [Support@cosmogrill.co.uk](mailto:Support@cosmogrill.co.uk)

4

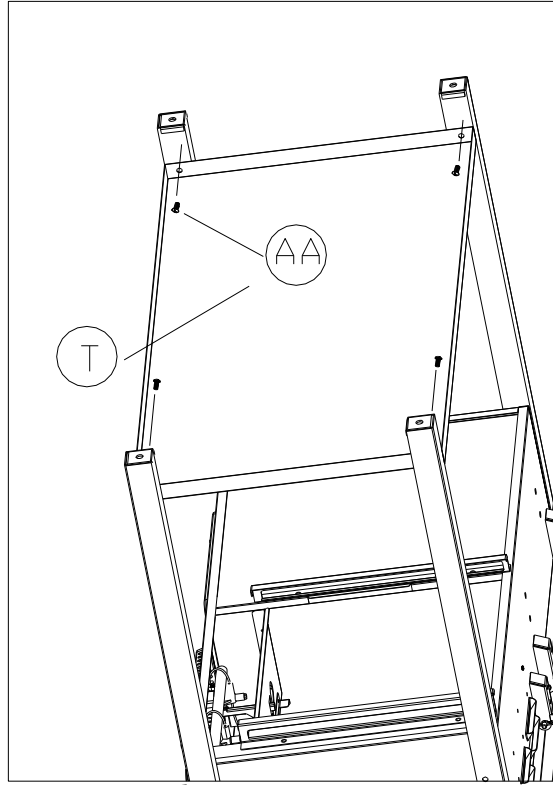

5

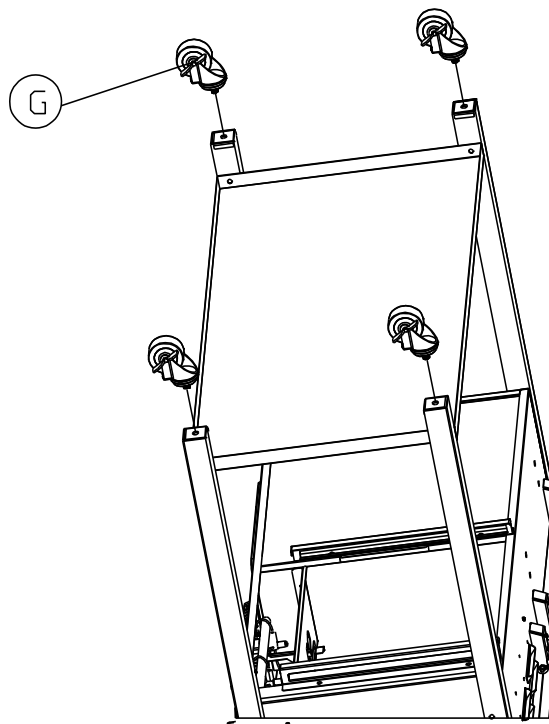

Thank you for purchasing from us! For help with your product please email us on: [Support@cosmogrill.co.uk](mailto:Support@cosmogrill.co.uk)

6

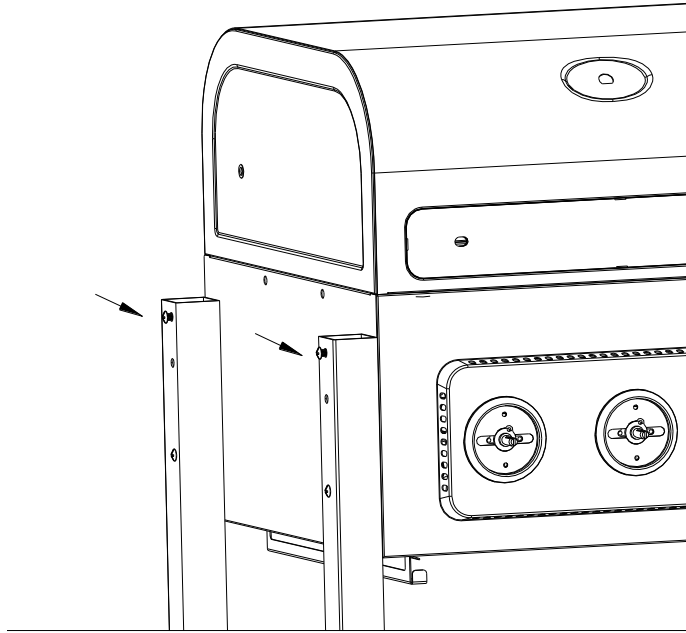

Rotate the pre-set two screws out of 6mm

7

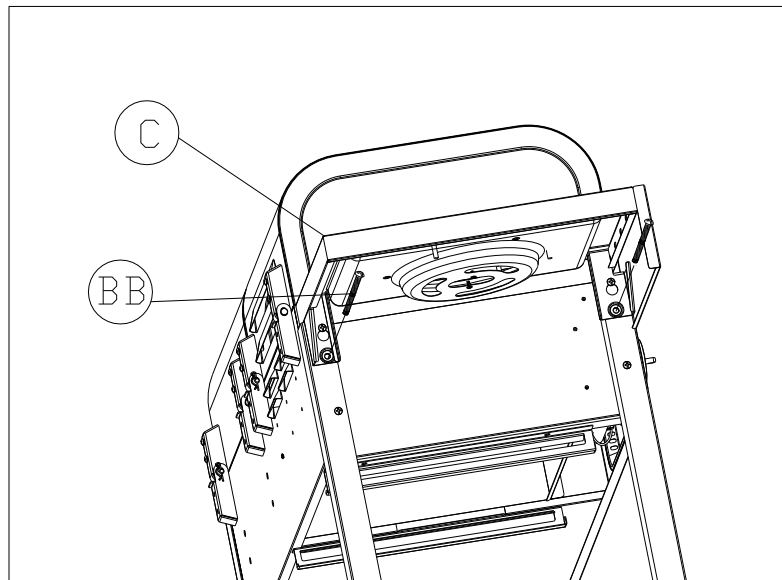

Thank you for purchasing from us! For help with your product please email us on: [Support@cosmogrill.co.uk](mailto:Support@cosmogrill.co.uk)

8

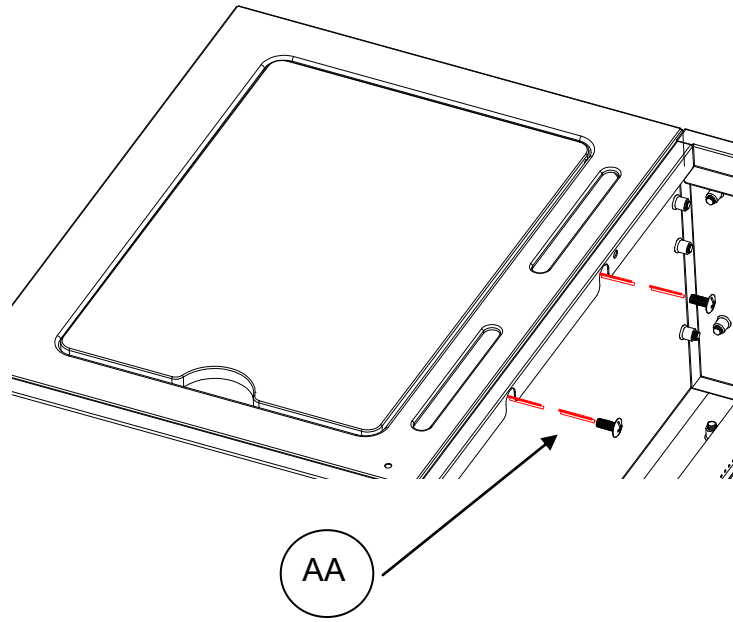

9

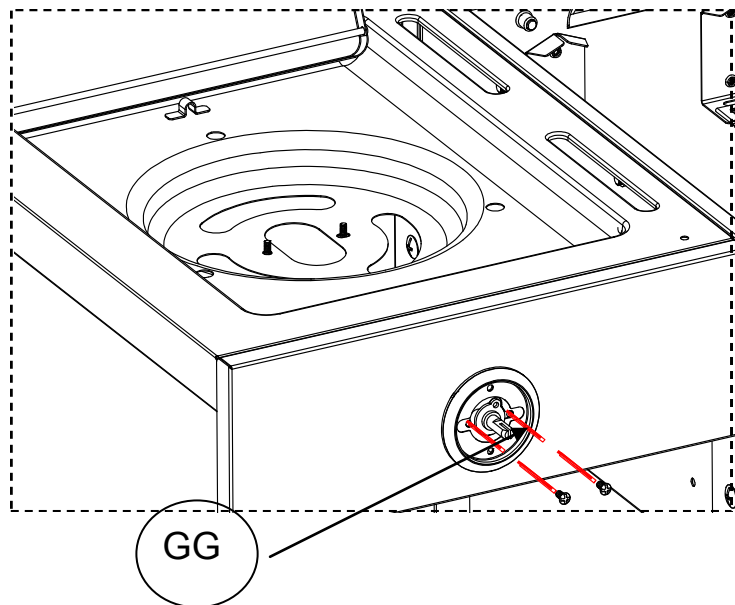

Thank you for purchasing from us! For help with your product please email us on: [Support@cosmogrill.co.uk](mailto:Support@cosmogrill.co.uk)

10

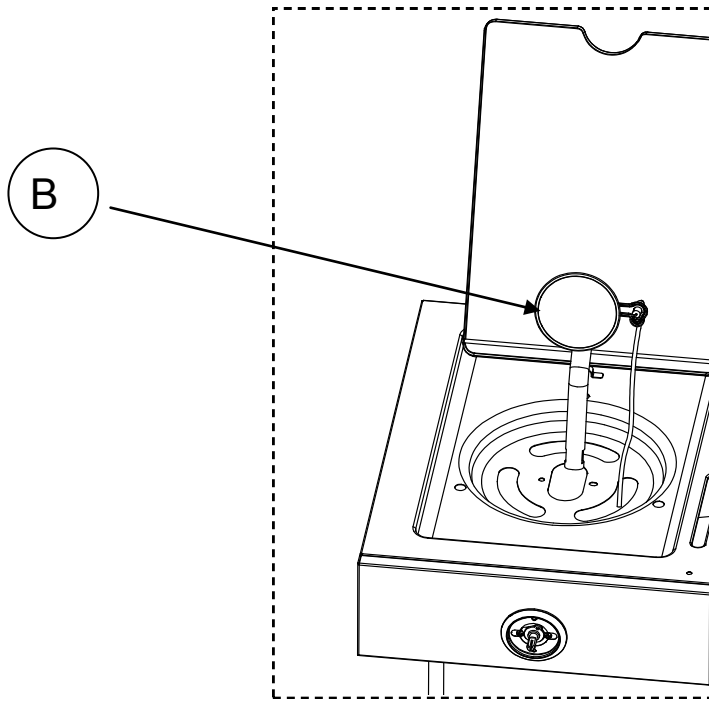

11

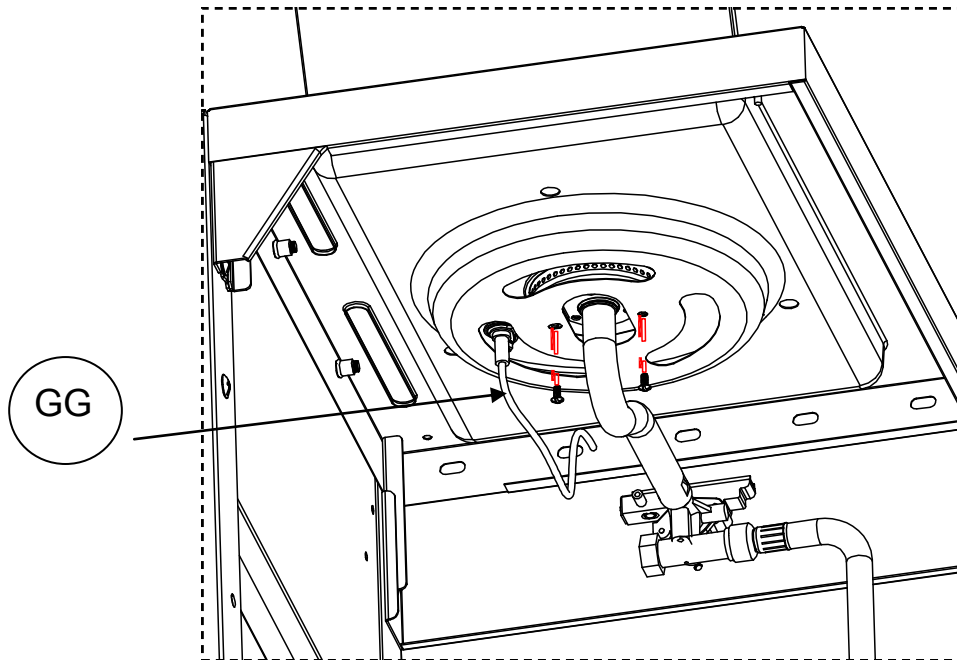

Thank you for purchasing from us! For help with your product please email us on: [Support@cosmogrill.co.uk](mailto:Support@cosmogrill.co.uk)

12

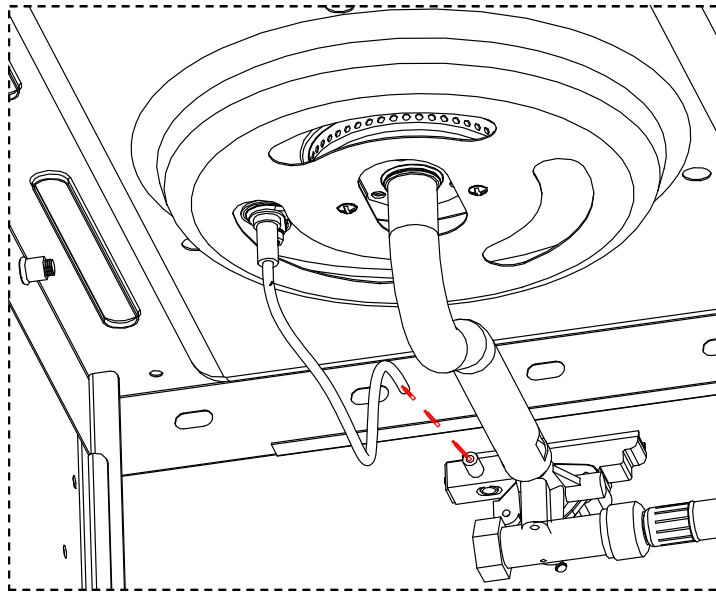

13

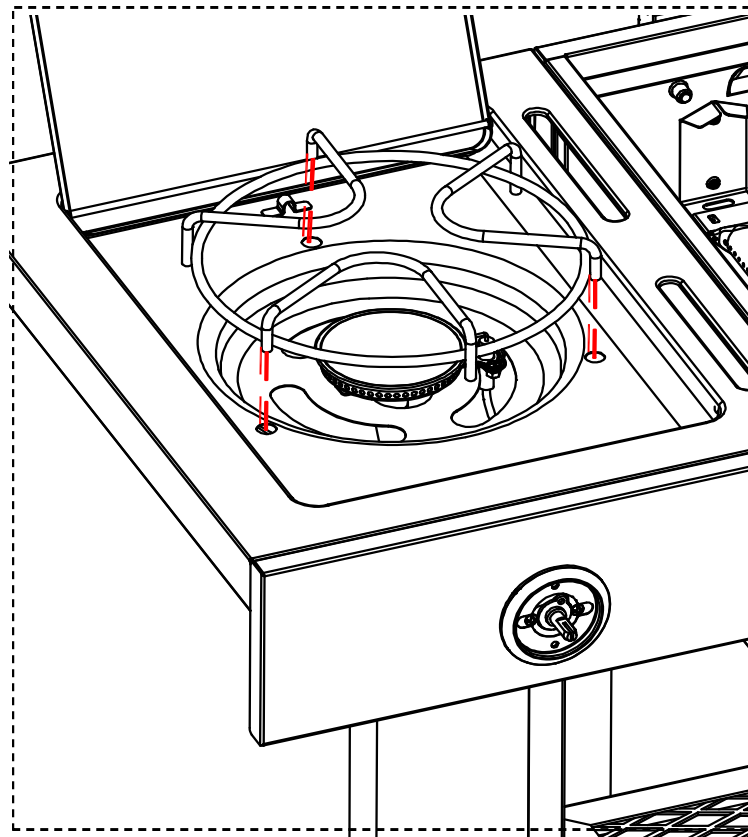

Thank you for purchasing from us! For help with your product please email us on: [Support@cosmogrill.co.uk](mailto:Support@cosmogrill.co.uk)



14

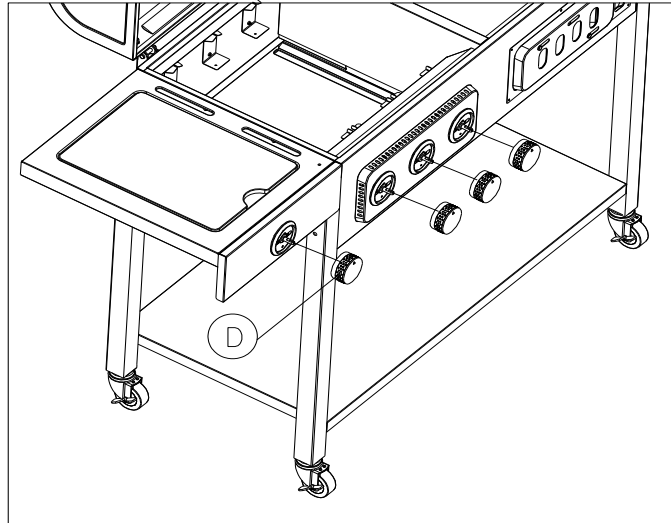

15

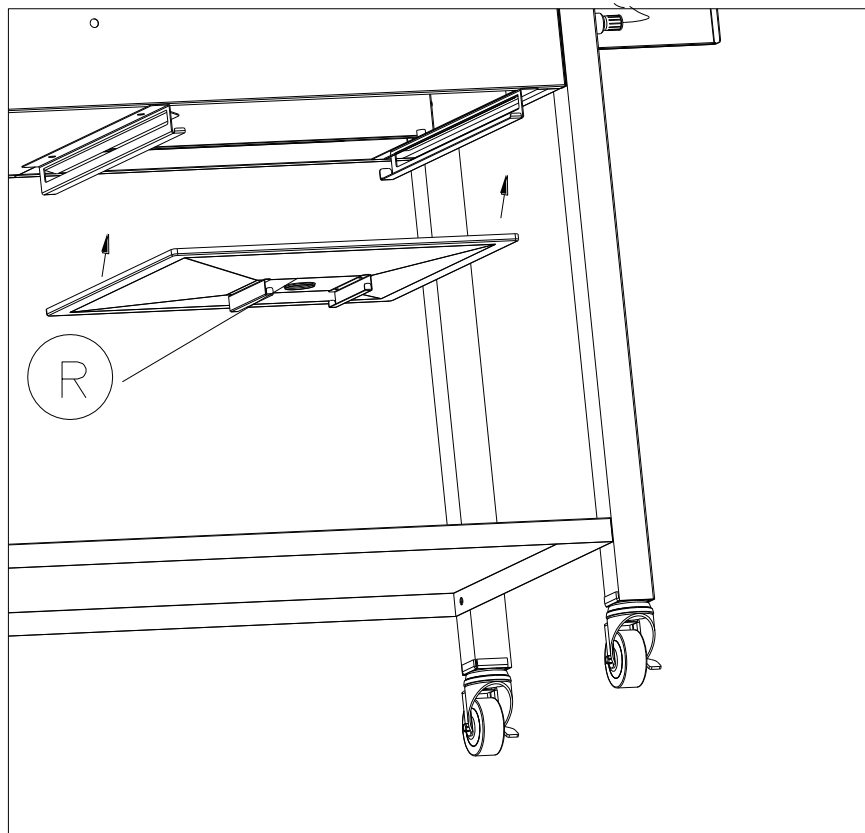

Thank you for purchasing from us! For help with your product please email us on: [Support@cosmogrill.co.uk](mailto:Support@cosmogrill.co.uk)

16

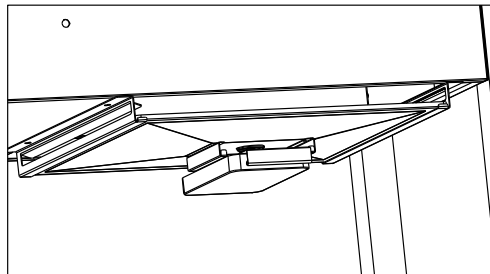
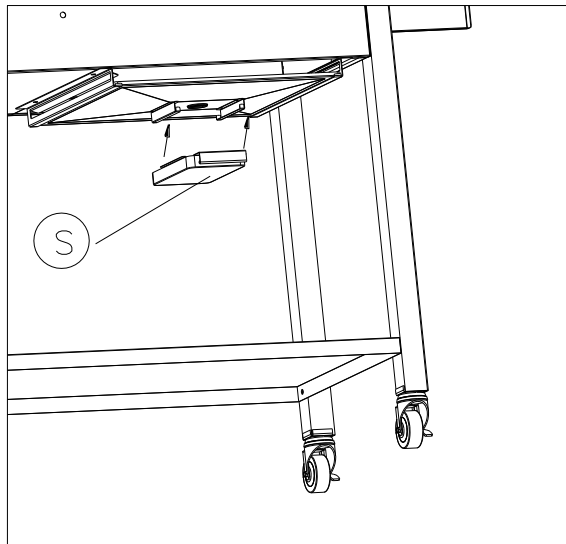

17

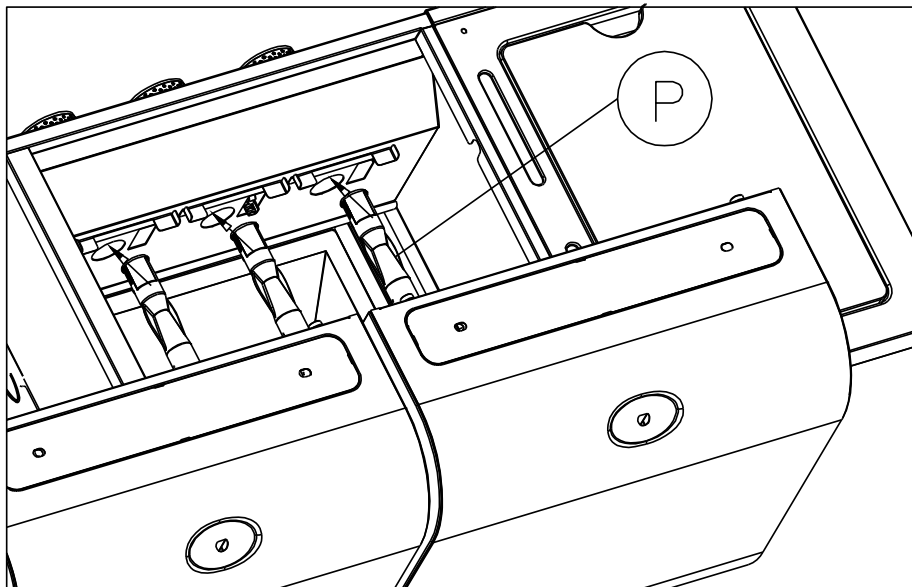

Thank you for purchasing from us! For help with your product please email us on: [Support@cosmogrill.co.uk](mailto:Support@cosmogrill.co.uk)

18

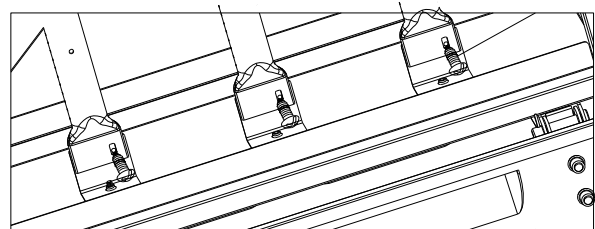
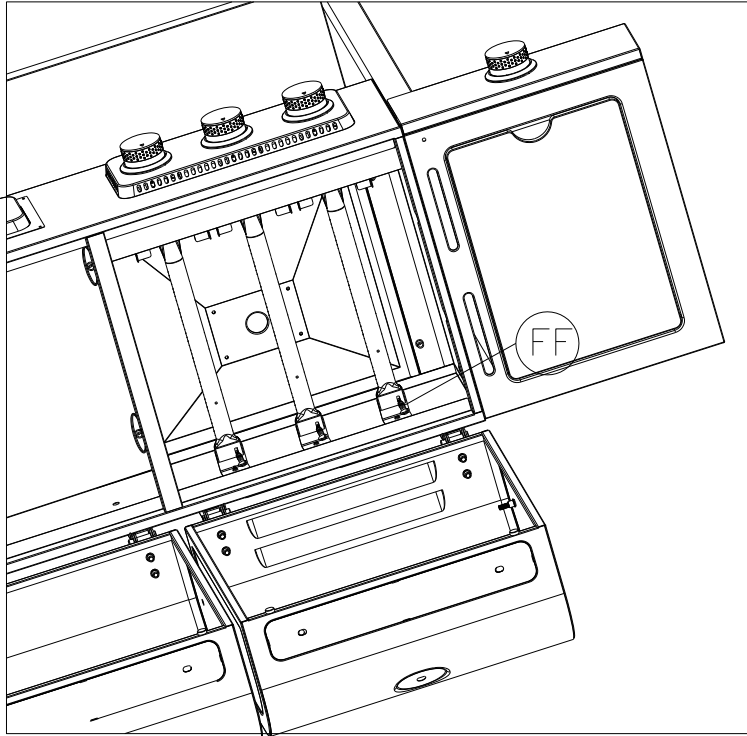

19

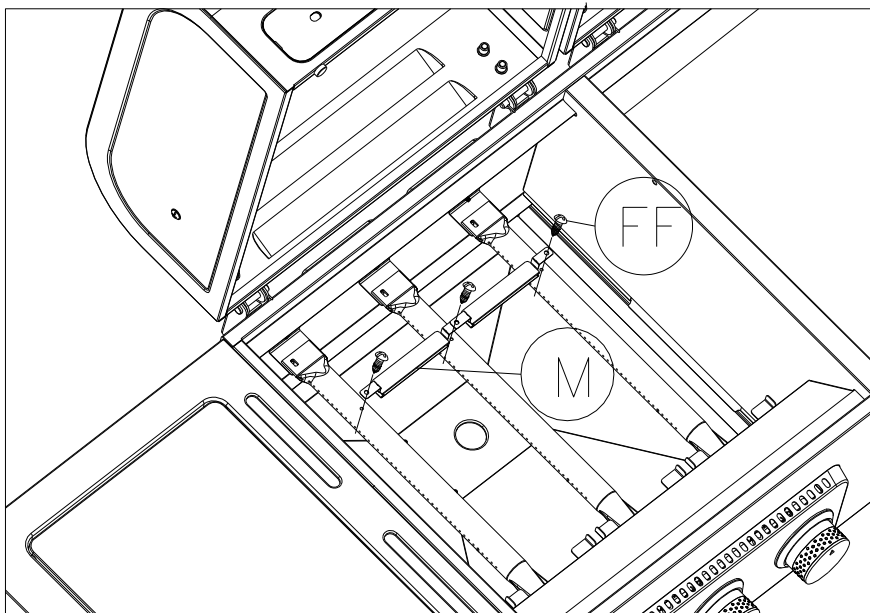

Thank you for purchasing from us! For help with your product please email us on: [Support@cosmogrill.co.uk](mailto:Support@cosmogrill.co.uk)

20

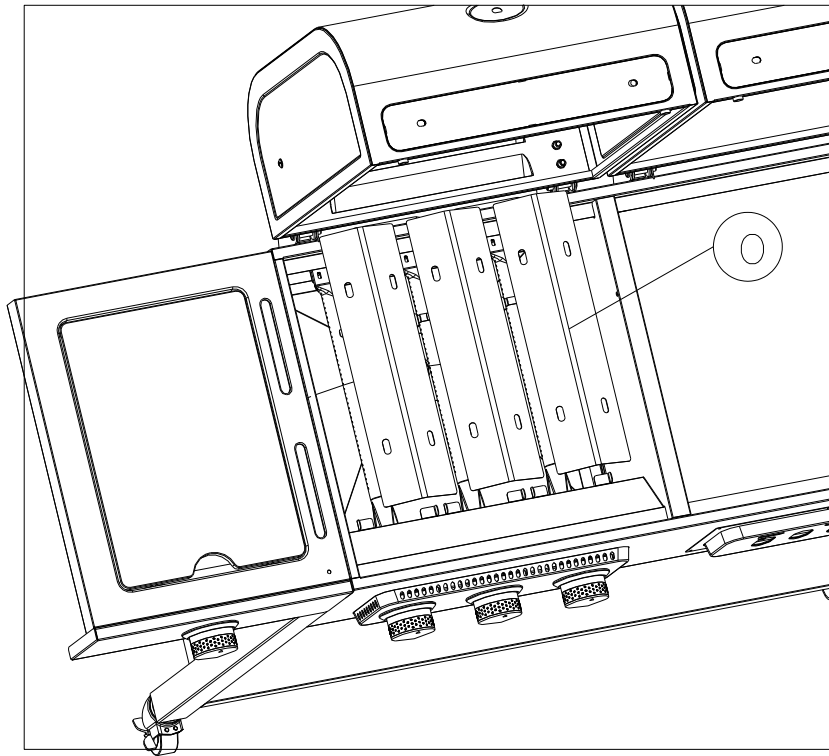

21

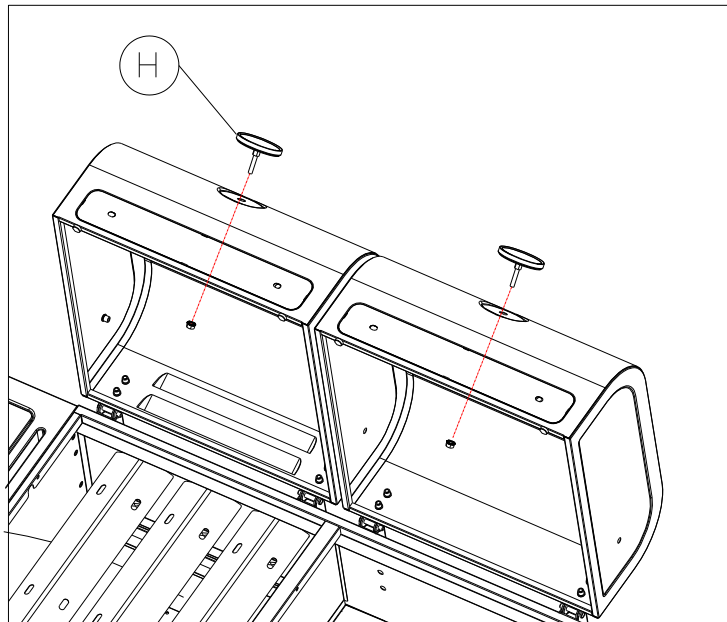

Thank you for purchasing from us! For help with your product please email us on: [Support@cosmogrill.co.uk](mailto:Support@cosmogrill.co.uk)

22

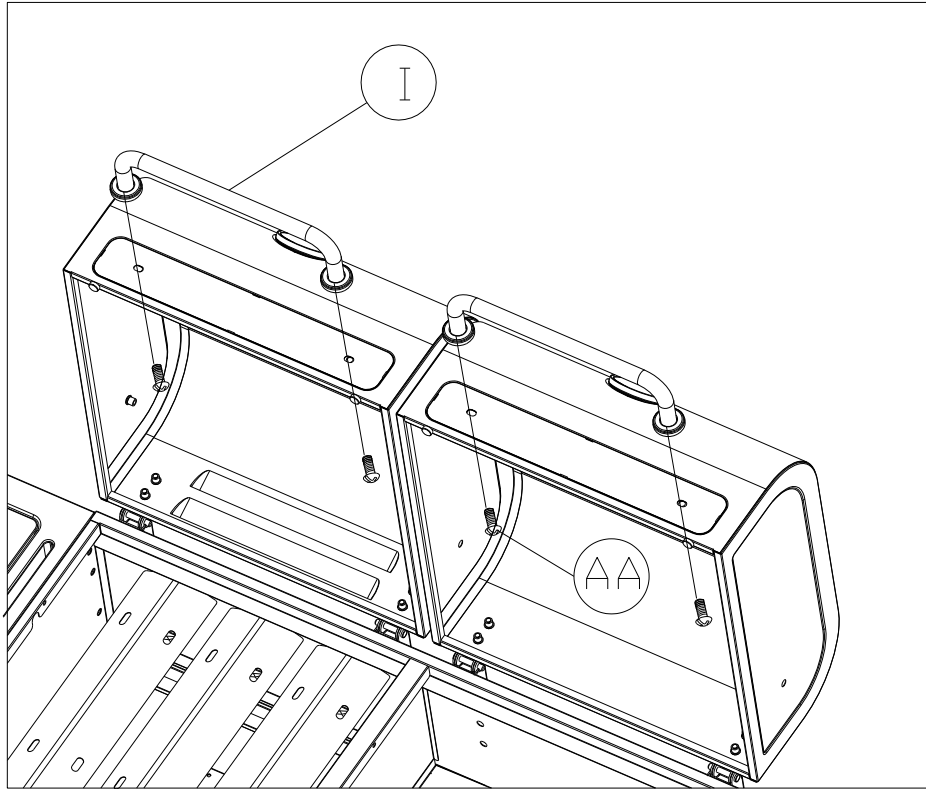

23

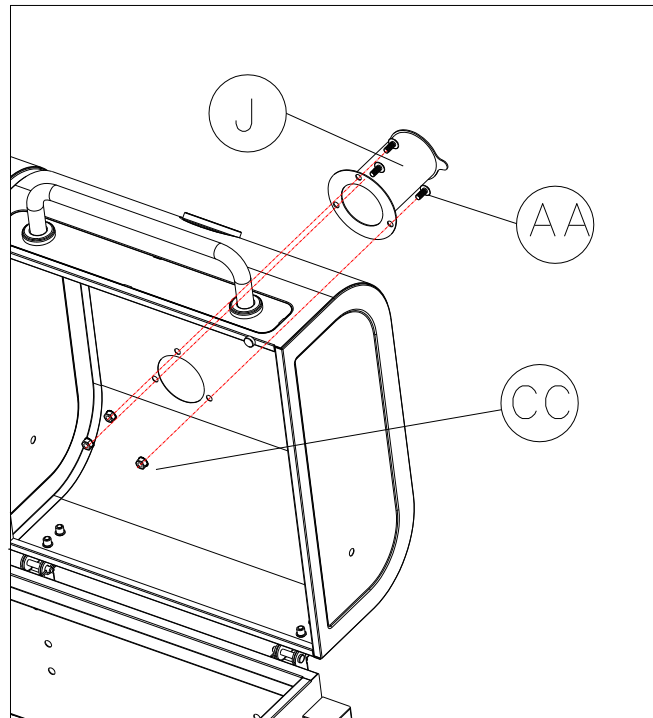

Thank you for purchasing from us! For help with your product please email us on: [Support@cosmogrill.co.uk](mailto:Support@cosmogrill.co.uk)

24

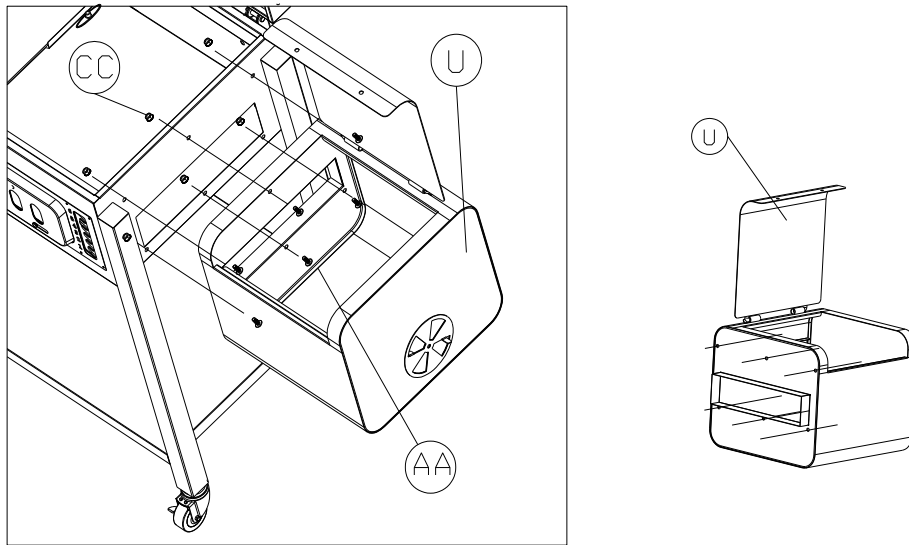

25

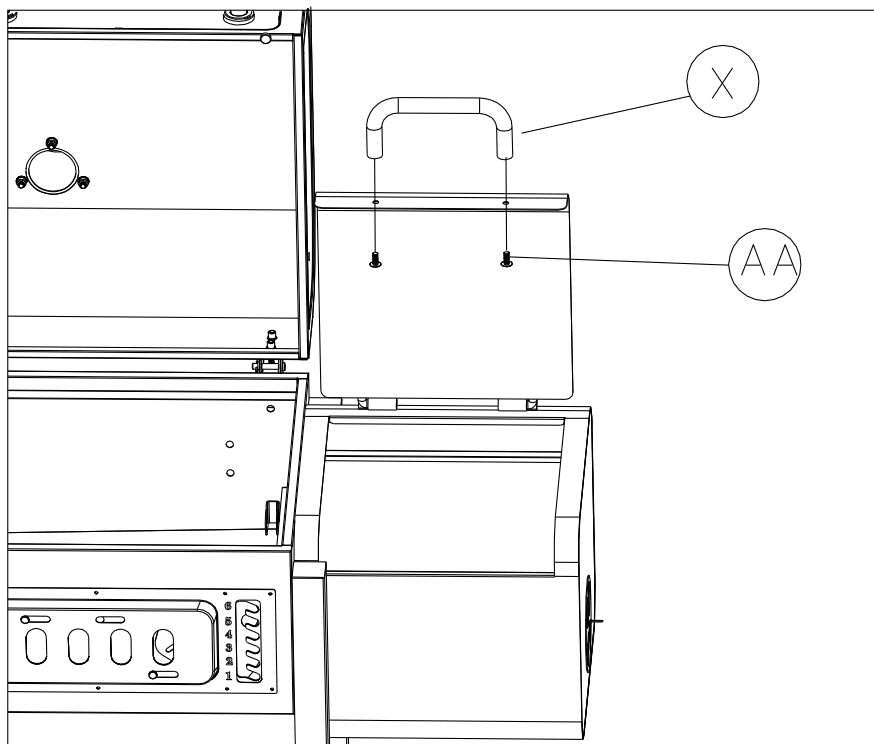

Thank you for purchasing from us! For help with your product please email us on: [Support@cosmogrill.co.uk](mailto:Support@cosmogrill.co.uk)

26

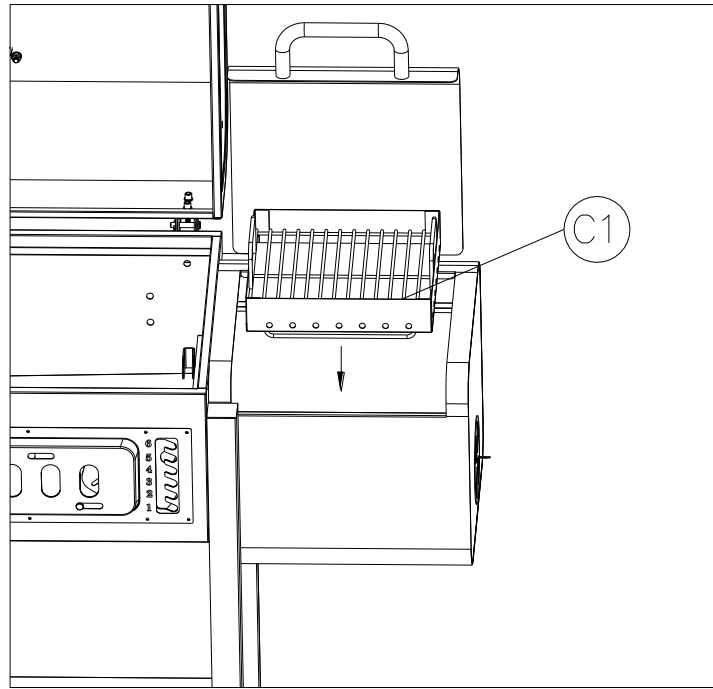

27

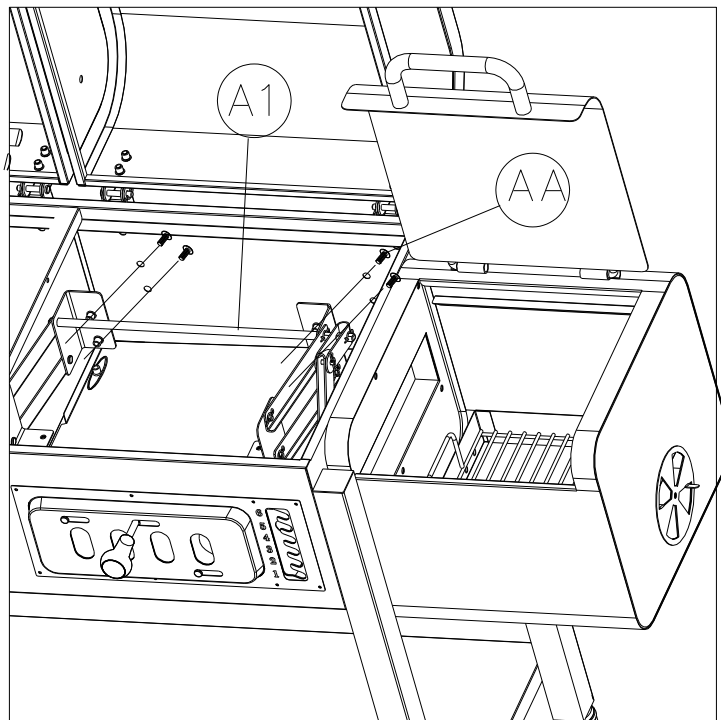

Thank you for purchasing from us! For help with your product please email us on: [Support@cosmogrill.co.uk](mailto:Support@cosmogrill.co.uk)

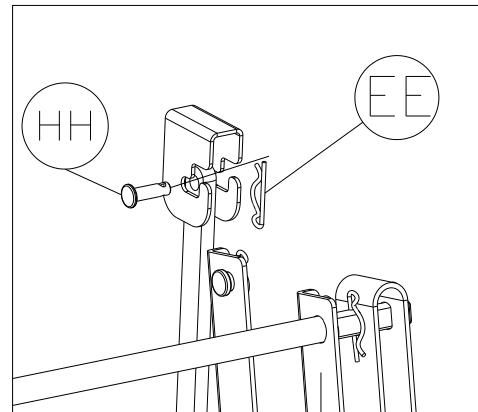
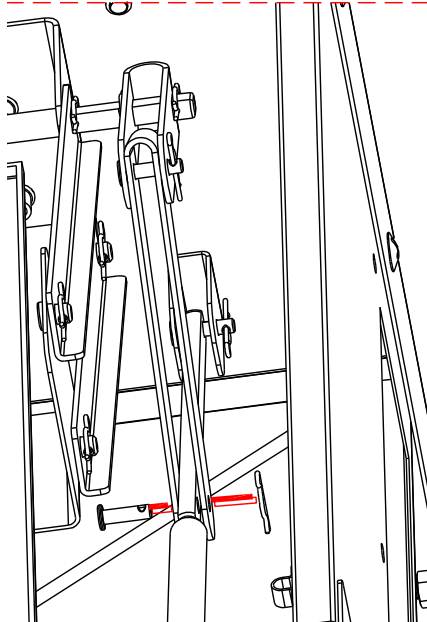
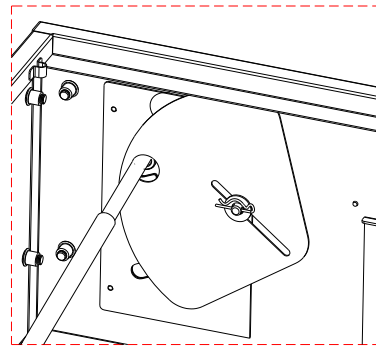
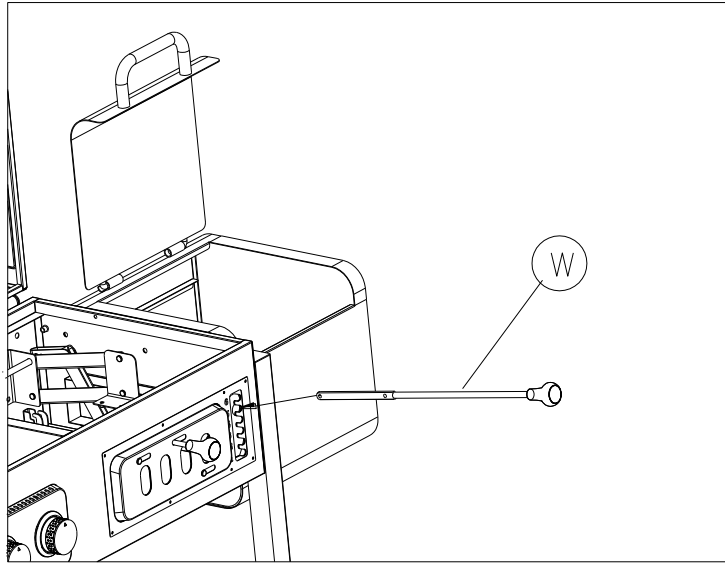

Thank you for purchasing from us! For help with your product please email us on: [Support@cosmogrill.co.uk](mailto:Support@cosmogrill.co.uk)



29

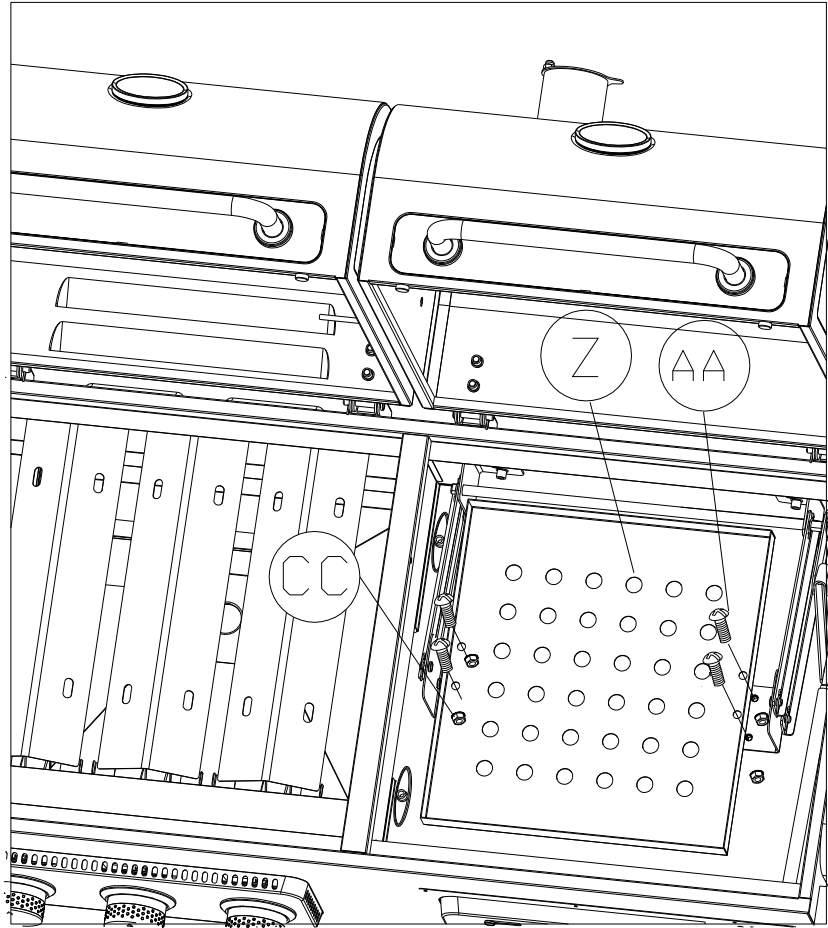

30

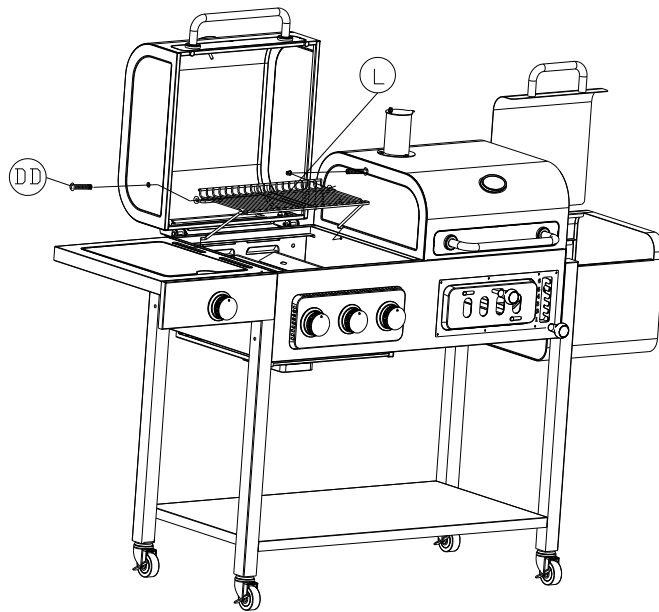

Thank you for purchasing from us! For help with your product please email us on: [Support@cosmogrill.co.uk](mailto:Support@cosmogrill.co.uk)

31

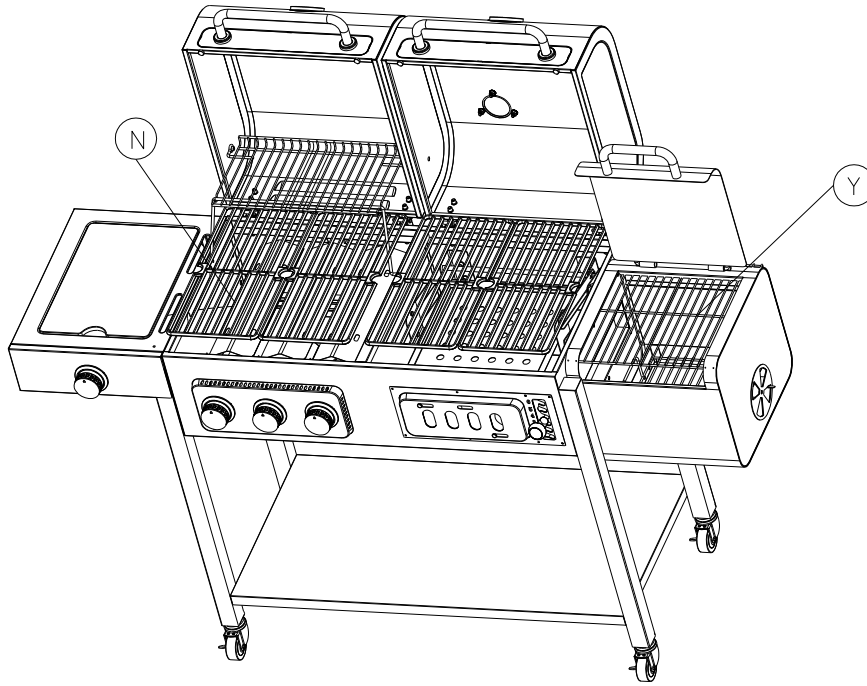

Thank you for purchasing from us! For help with your product please email us on: [Support@cosmogrill.co.uk](mailto:Support@cosmogrill.co.uk)