

Content

Purpose	1
Scope	1
Disposal.....	1
Target Group.....	1
Safety Instructions.....	2
Preface	3
1 Introduction.....	4
1.1 Brief Introduction	4
1.2 Products Features.....	4
2 Product Specification.....	5
2.1 Size and Weight.....	5
2.2 Parameters.....	5
2.3 Interface Setting.....	6
2.3.1 DIP Switch Definition and Description	7
2.4 Batteries Management System(BMS).....	8
2.4.1 Voltage Protection.....	8
2.4.2 Current Protection.....	8
2.4.3 Temperature Protection	9
2.4.4 Other Protection	9
3 Installation and Configuration.....	10
3.1 Ready for installation.....	10
3.1.1 Environmental requirements	10
3.1.2 Tools and data	11
3.1.3 Technical preparation.....	11
3.1.4 Unpacking inspection.....	12
3.1.5 Engineering coordination	13
3.2 Equipment installation.....	13
3.2.1 Installation preparation.....	14
3.2.2 Electrical installation.....	14
3.3 BL3.6 Batteries Connecting Illustration	14
4 Use, maintenance and troubleshooting.....	20
4.1 Batteries system usage and operation instructions.....	20
4.2 Alarm description and processing.....	21
5 Communication with inverter brand.....	23
6 Packing List.....	23

Purpose

This manual describes the assembly, installation, operation and troubleshooting of the unit. Please read this manual carefully before installation and operation. Keep this manual for future reference.

Scope

This manual provides safety and installation instructions as well as information on tools and wiring.

Disposal

The storage, use and disposal of the products shall be carried out in accordance with the product manual, relevant contract or local environmental laws and regulations.

Target Group

This document is intended for qualified individuals; however procedures that do not require qualification may be performed by end users.

A qualified person requires having the relevant know-how and experience in the operation and installations of lithium batteries, and electrical devices (in particular inverters). Additionally, Knowledge of the applicable standards and safety procedures related to the aforementioned installations.

Safety Instructions

The following clause contains important safety and operating instructions please review carefully.



Caution

- **Caution: installing batteries, especially with inverters, carries a high-risk of electrocution or fire.**
- **Installation may only be performed by a qualified person.**
- Connect wires firmly and do not reverse polarity or bridge between poles.
- Do not puncture, drop or cause any physical damage to the batteries.
- Keep the batteries dry at all times, and avoid wet or humid environments where batteries are installed.
- Do not expose batteries to open flames or high temperature environments.
- Shut power off when maintain or removing batteries.
- In case of fire only use dry powder extinguisher or other non-liquid methods to extinguish flames.
- Do not disassemble the batteries.
- If the batteries exhibit any faults please contact the agent or supplier, do not attempt to repair by unauthorised person.
- When installed batteries shall be grounded.
- Only use with compatible devices (especially inverters).
- Do not install the BL3.6 Lithium Batteries with any other lithium batteries.
- When not in use (storage) batteries should be recharged once every 6 months, and the Charge shall not exceed 80% of the rated capacity.
- Working temperatures are between -20°C and 60°C .
- Avoid dust where possible.
- Please charge the batteries as soon as it gets empty because that will help to keep cycle life span.

Failure to comply with any of the above may damage the batteries and void the warranty.

Preface

Manual Declaration

The BL3.6 lithium iron phosphate batteries energy storage system can provide energy storage solutions for photovoltaic power generation users through parallel combination. This user manual details the basic structure parameters, basic procedures and methods of installation and operation and maintenance of the equipment.

1.Introduction

1.1 Brief Introduction

The BL3.6 Lithium Batteries are energy storage devices are intended for the use in backup power and solar energy solutions.

1.2 Products Features:

BL3.6 energy storage product's anode materials are lithium iron phosphate, batteries cells are managed effectively by BMS with better performance, the system's features as below:

- The BL3.6 Lithium Batteries offer high performance with 115A discharge current.
- The batteries are manufacture with a quality lithium iron phosphate (LiFePO4) cells for extended life cycle.
- The batteries' cells are managed by the latest Batteries Management System (BMS) for improved performance and protection against over-discharge / charge / current and high temperatures.
- Our products comply with European ROHS standards, are SGS Certified and are composed of nontoxic environment-friendly materials.
- The batteries are stackable (Maximum of 15 units) for use in large energy storage solutions.
- The batteries offer a high depth of discharge (DOD) and low cut off voltage for maximum use.

2.Prodcut Specification

2.1 Size and Weight

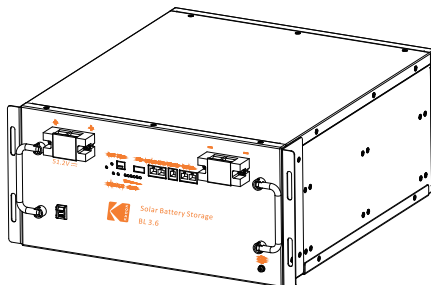

Batteries size: ~442mm*512mm*222mm
Batteries weight: ~42kg

2.2 Parameters

SPECIFICATIONS	
MODEL	BL3.6
Rated Power	5000W
Parallel Capability	Up to 15 units
Basic parameter	
Rated Voltage	51.2V/72Ah
Nominal capacity	3.686kWh
PHYSICAL	
Dimension, D x W x H (mm)	222 x 442 x 512
Net Weight (kgs)	42kg
Communication Interface	RS232/RS485/CAN
Electrical parameter	
Charge mode	CC/CV/CP
Max.Charge Current ¹⁾	50A
Charging cut-off voltage	57.4V
Discharge mode	CC/CP
Discharging cut-off voltage	44.8V
Max.Discharge Current ²⁾	115A
Peak Discharge Current ³⁾	350A(100ms)
ENVIRONMENT	
Humidity	5% to 95% Relative Humidity (Non-condensing)
Operating Temperature	Charge: 0~+45°C/Discharge: -20~+60°C
Storage Temperature	-20~+45°C (three months) /-20~+25°C (one year)
Shipment status	Voltage: 52V~54V SOC: 60%~80%
Warranty	
10 years warranty, > 6000 cycles life	
All information contained in this document is subject to change without notice.	
1)For better battery life cycles,we suggest charge in 36A(0.5C @25°C)	
2)For better battery life cycles,we suggest discharge in 36A(0.5C @25°C)	
3)Peak Current excludes repeated short duration (less than 100ms) of current pattern.	

2.3 Interface Setting

This section details the front interface of the batteries.

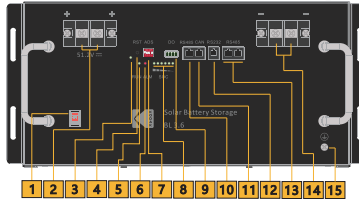

Item	Name	Definition
1	Power switch	ON/OFF, must be in the "ON" state when in use
2	Positive terminal	Batteries output positive or parallel positive line
3	ON/OFF light	Instructions shown as in 4.2
4	Reset	Press this button may awake the batteries when the power switch is "ON"
5	Run	Instructions shown as in 4.2
6	ALM	Instructions shown as in 4.2
7	ADS	DIP switch
8	SOC	Instructions shown as in 4.2
9	DO	Dry Contact
10	RS485	RS485, communication between the batteries and inverter
11	CAN	CAN Communication
12	RS232	RS232 Communication
13	RS485	RS485, communication between batteries
14	Negative terminal	Batteries output positive or parallel negative line
15	Ground	Shell ground connection

2.3.1 DIP Switch Definition and Description

Set the master batteries dip switch 1 to the ON position (up), for the first slave batteries set dip switch 2 ON, for the second slave batteries set dip switch one and two to ON, for the third batteries set dip switch 3 to ON (see illustration below).

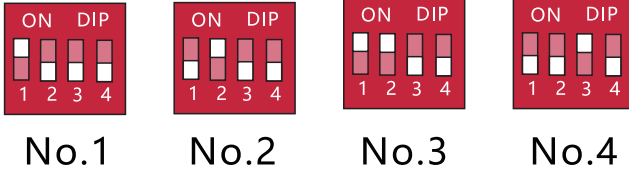

Address	Position of the dial code switch			
	#1	#2	#3	#4
1	ON	OFF	OFF	OFF
2	OFF	ON	OFF	OFF
3	ON	ON	OFF	OFF
4	OFF	OFF	ON	OFF
5	ON	OFF	ON	OFF
6	OFF	ON	ON	OFF
7	ON	ON	ON	OFF
8	OFF	OFF	OFF	ON
9	ON	OFF	OFF	ON
10	OFF	ON	OFF	ON
11	ON	ON	OFF	ON
12	OFF	OFF	ON	ON
13	ON	OFF	ON	ON
14	OFF	ON	ON	ON
15	ON	ON	ON	ON

Table 2—1

Maximum of 15 batteries in parallel is supported, and the address codes for each battery must be different.

2.4 Batteries Management System(BMS)

2.4.1 Voltage Protection

Low-voltage protection

The batteries will disconnect when low-voltage cut off is reached and recover once charged above the low-voltage value.

Over-voltage protection

The batteries will stop charging when max-voltage cut off value is reached, charging will resume once the voltage goes under setting value.

2.4.2 Current Protection

Over-current charge protection

The batteries will stop charging when current exceed the maximum allowed current, charging will resume once the voltage goes under setting value.

Over-current discharge protection

When the discharge current is larger than the protection value, the batteries will stop discharging. And protection will be released after rated delay time.

2.4.3 Temperature Protection

Under/Over temperature protection in charge

When the temperature of the batteries is beyond range of $0^{\circ}\text{C} \sim +55^{\circ}\text{C}$ during charging, temperature protection will be triggered and the batteries will stop charging. The protection will be released when it recovers to rated return range.

Under/Over temperature protection in discharge

The batteries allowed working temperature is between -20°C and 60°C , the batteries will be disconnected if these values are exceeded. The batteries will resume operation once temperature reaches allowed values.

2.4.4 Other Protection

Short Circuit Protection

When there is a short circuit situation, the short-circuit protection will be triggered, and the protection will be released after the load is removed or there's a charging source connected.

Self — Shutdown

When there are no external loads and power supply and no external communication for over 24 hours, the device will dormant standby automatically.

3 Installation and Configuration

3.1 Ready for installation

Safety Requirement

This system can only be installed by personnel who have been trained in the power supply system and have sufficient knowledge of the power system.

The safety regulations and local safety regulations listed below should always be followed during the installation.

- All-circuits connected to this power system with an external voltage of less than 48V must meet the SELV requirements defined in the IEC60950 standard.
- Only use Inverters and other equipment that are compatible with the batteries i.e. 48 volts inverters and inverter which are compatible with lithium batteries.
- Use the suitable cable size for the expected load current.
- Sufficient space is available for the batteries.
- Sufficient ventilation exists as to avoid overheating of the batteries and other equipment.
- Use adequate personal protective equipment (PPE) when installing a batteries.
- If a batteries cabinet or rack is used that it is installed correctly and can carry the batteries weight.
- The power line specification shall meet the requirements of maximum discharge current for each product.

3.1.1 Environmental requirements

Working temperature: $-20^{\circ}\text{C} \sim +60^{\circ}\text{C}$

- Charging temperature range is $0^{\circ}\text{C} \sim +60^{\circ}\text{C}$,
- Discharging temperature range is $-20^{\circ}\text{C} \sim +60^{\circ}\text{C}$

Storage temperature: $-10^{\circ}\text{C} \sim +35^{\circ}\text{C}$

Relative humidity: 5% ~ 85%RH

Elevation: no more than 4000m

Operating environment: Indoor installation, sites avoid the sun and no wind, no conductive dust and corrosive gas.

And the following conditions are met:

- Installation location should be away from the sea to avoid brine and high humidity environment.
- The ground is flat and level.
- There is no flammable explosive near to the installation places.
- The optimal ambient temperature is $15^{\circ}\text{C} \sim 30^{\circ}\text{C}$
- Keep away from dust, high humidity and condensation areas

3.1.2 Tools and data

Hardware tool

Tools and meters that may be used are shown in table 3—1.

Table 3—1 Tool instrument

Name	
Screwdriver	AVO meter
Wrench	Clamp meter
Inclined pliers	Insulating tape
Needle nose pliers	The thermometer
Clip forceps	Wrist strap
Wire stripper	AVO meter
Electric drill	Tape

3.1.3 Technical preparation

Electrical interface check

Devices that connected directly to the batteries can be user equipments, power supplies, and other power supplies.

- Please check if the user's PV power generation equipment, power supplier or other power supply equipment has a DC output interface, and the voltage meet the requirements of the inverter.
- And check the maximum discharge current capability of the DC power interface of the user's photovoltaic power generation equipment, power supply or other power supply equipment should be greater than the maximum charging current of the products.

The security check

3.1.4 Unpacking inspection

- Firefighting equipment should be provided near the equipment, such as portable dry powder fire extinguisher.
- No flammable, explosive and other dangerous articles are placed beside the batteries.
- When the equipment arrives at the installation site, loading and unloading should be carried out according to the rules and regulations, to prevent from being exposed to sun and rain.
- Before unpacking, the total number of packages shall be indicated according to the shipping list attached to each package, and the case shall be checked for good condition.
- In the process of unpacking, handle with care and protect the surface coating of the object.
- After the package is open, the installation package should read the technical documents, verify the list, according to the configuration table and packing list, ensure objects are complete and intact, if the internal package is damaged, examined and recording will be required.

3.1.5 Engineering coordination

Attention should be paid to the following items before construction

- Power line specification:
The power line specification shall meet the requirements of maximum discharge current for each product.
- Mounting space and bearing capacity:
Make sure that the batteries has enough room to install, and that the batteries rack and bracket have enough load capacity.
- Make sure the power line and ground wire are reasonable. Not easy to short-circuit, water and corrosion

3.2 Equipment installation

Table 3-2 Installation steps

Step1	Installation preparation	Confirm that the ON/OFF switch on the front panel of BL3.6
Step2	Mechanical Installation	1. Cabinet placement position determination
		2. Top cable harness pre-installed
		3. Batteries module installation
Step3	Electrical Installation	1. Ground cable installation
		2. Batteries module parallel cable installation
		3. Batteries module total positive cable installation
		4. Batteries module total negative cable installation
		5. Internal RS485 communication interface connection
Step4	Batteries System self-test	1. Press the ON/OFF switch to the "ON" state
		2. BMS system power—on activation
		3. Check the system output voltage
		4. Shut down the system
Step5	Connecting inverter	1. Connect total positive & total negative cable of the
		2. Connect the external RS485 communication cable to the inverter

3.2.1 Installation preparation

1. Prepare equipment and tools for installation
2. Check if the switch of the batteries unit is in the "OFF" state to ensure no live operation.

3.2.2 Electrical installation

Before connecting the power cables, using multimeter to measure cable continuity, short circuit, confirm positive and negative, and accurately mark the cable labels. Measuring methods:

- Cable availability: select the buzzer and use the probe to measure the ends of the same color cable. If the buzzer calls, it means the cable is available.
- Short circuit judgment: choose multimeter resistor file, probe the same end of positive and negative pole, if the resistor shows infinity, means that the cable is available.
- After visual testing of power line is connected well, the positive and negative poles of the batteries shall be connected respectively to the positive and negative poles of the opposite terminal

It is better to add a circuit breaker between the inverter and the batteries system. The selection of the circuit breaker requires:

Voltage: $U > 60V$

$$\text{Current: } I = \frac{\text{Inverter power}}{45V}$$

3.3 BL3.6 Batteries Connecting Illustration

3.3.1 The accessory 3AWG wire of BL3.6 can support current of 115A at most, so, when the inverter is parallel connected, and the output power of the inverter exceeds 5KW, additional main wire may be needed to realize the function of the whole system.

3.3.2 Take the inverter output power of 10KW, 15KW, and 20KW as an example:

- a) When two 5KW inverters are combined in parallel, the total output of the batteries will be 10KW, so the main wire will take 200A current at most. If the accessories, 4AWG or 6AWG wire is used to delivered 200A current, there will be serious heating and even the risk of component failure. Therefore, it is suggested to use design the main wire as designed in the schematics.

The current capacity of the main wire should not exceed 200A, and the batteries and the main wire should be connected point-to-point.

The two inverters communicate with the host batteries 1# through the Hub, as the schematic shows.

b)The wiring of 15KW and 20KW output power of the inverter are similar with 10KW.

Note: the red wire represents the main line of positive electrode, the positive electrode of a single batteries (purple wire) should be connected directly to the main wire; and the black wire represents the main wire of negative electrode, the negative electrode of a single batteries should be connected directly to the main wire.

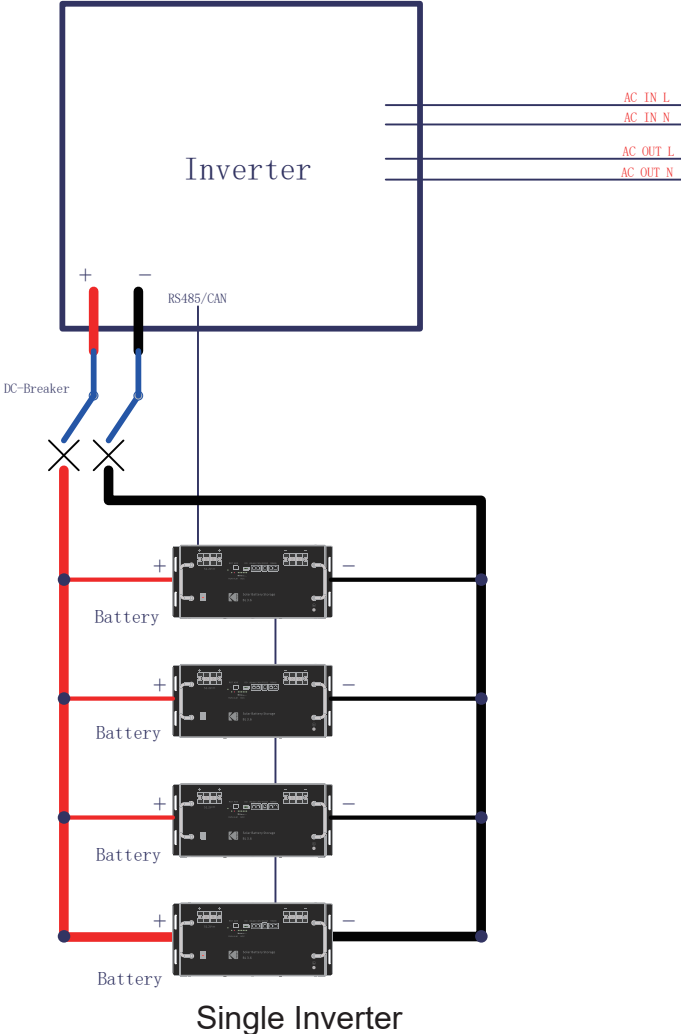

*Busbar Connection Recommended

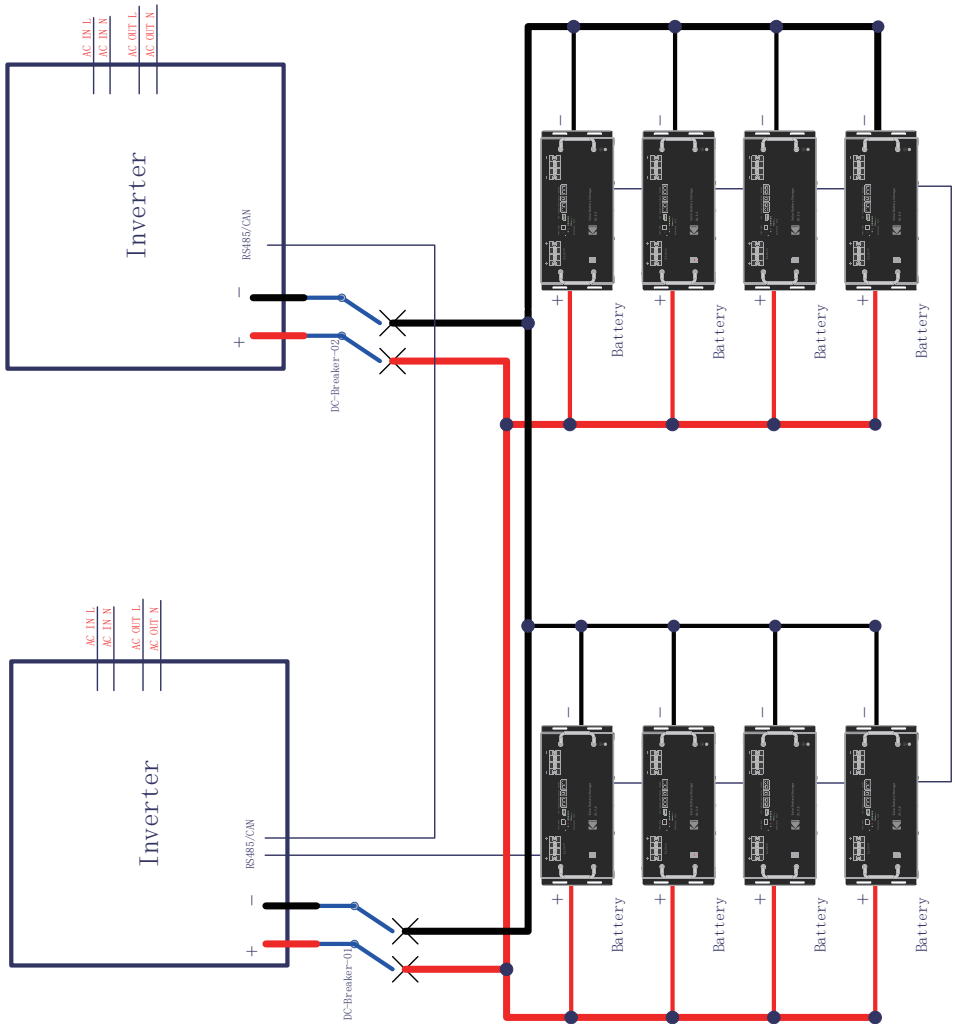

Two Inverters in Parallel

*Busbar Connection Recommended

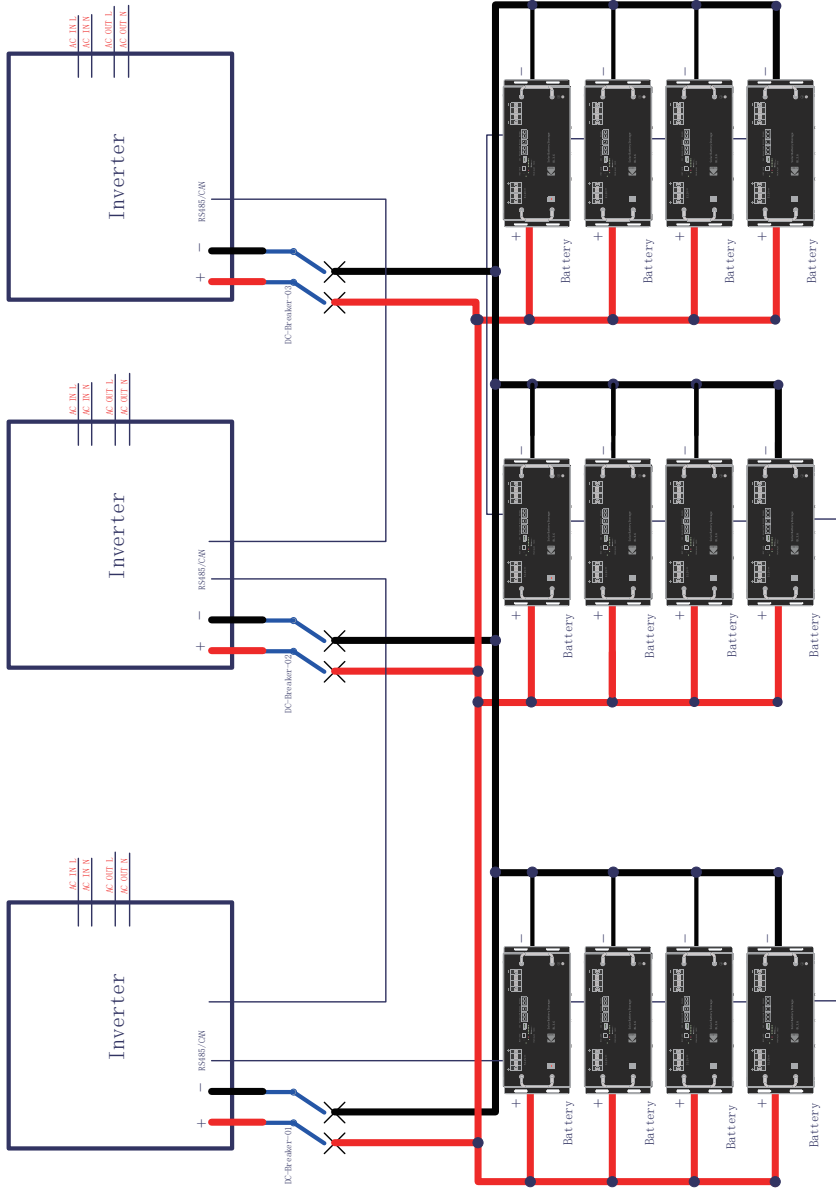

Three Inverters in Parallel

*Busbar Connection Recommended

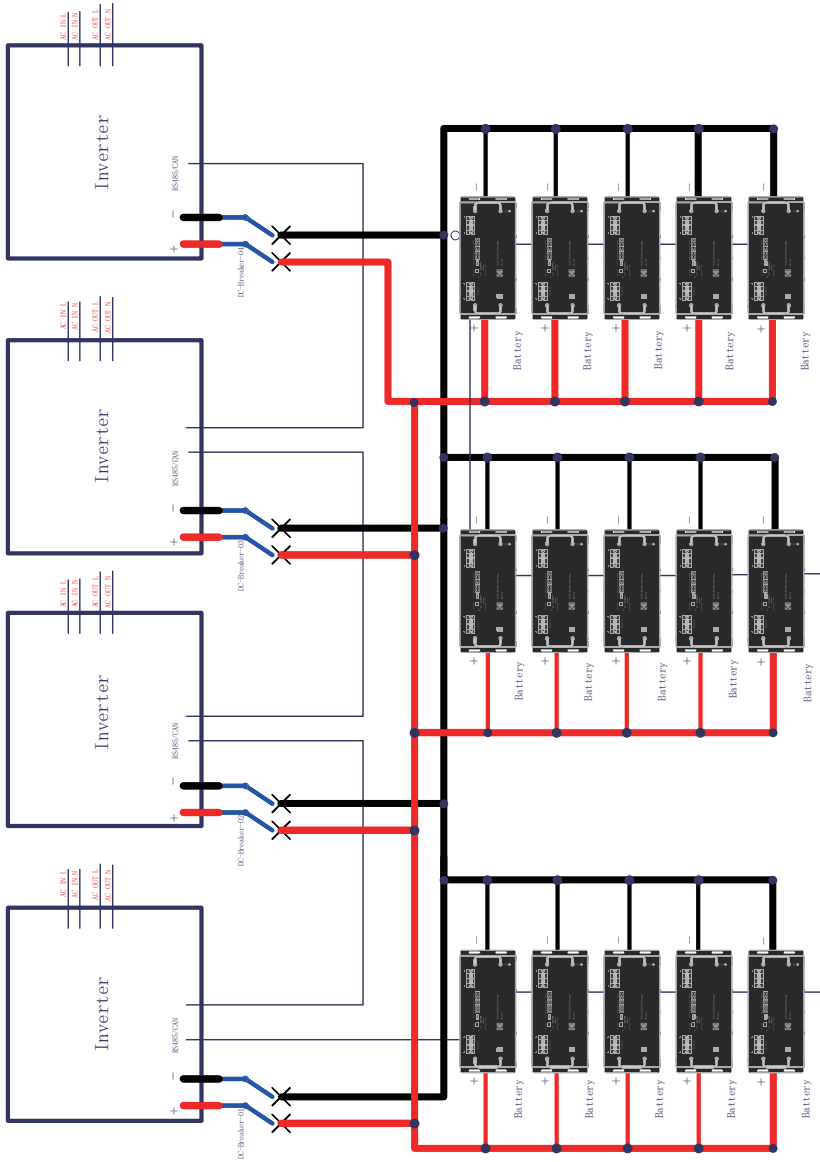

Four Inverters in Parallel

*Busbar Connection Recommended

The circuit breaker is installed between the batteries module and the inverter , as shown in Figure:

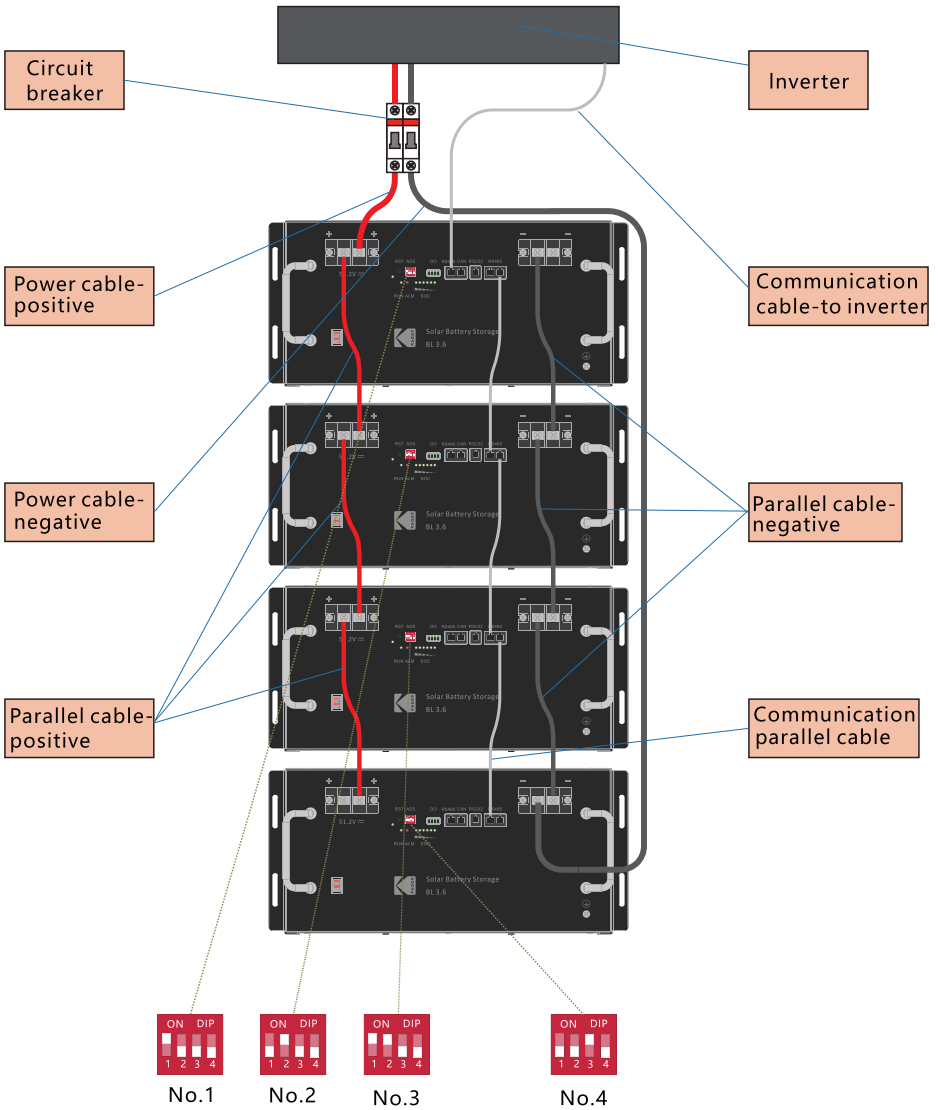

4 Use, maintenance and troubleshooting

4.1 Batteries system usage and operation instructions

After completing the electrical installation, follow these steps to start the batteries system.

- 1.Refer to the description of the DIP switch of 2.3.1 to prepare the batteries module before starting up, then press the ON/OFF button to the ON position.

After the indicator self-test, the RUN indicator will light and the SOC indicator will be on (100% SOC status in the Figure4-1).

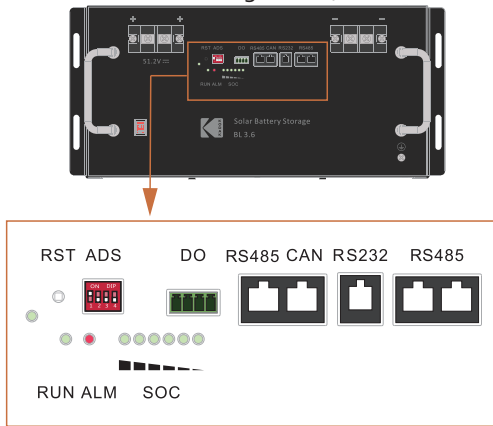









Figure4-1

Note:

- 1.After pressing the power button, if the batteries status indicator on the front panel continues to be red, please refer to the "4.2 Alarm description and processing ". If the failure cannot be eliminated, please contact the dealer timely.
2. Use a voltmeter to measure whether the voltage of the circuit breaker batteries access terminal is greater than 42V, and check whether the voltage polarity is consistent with the inverter input polarity. If the circuit breaker batteries input terminal has a voltage output and is greater than 42V, then the batteries has started normal work.
- 3.After confirming that the batteries output voltage and polarity are correct, turn on the inverter, close the circuit breaker.
- 4 Check if the indicator of the inverter and batteries connection (communication indicator and batteries access status indicator) is normal. If it is normal, successfully complete the connection between the batteries and the inverter. If the indicator light is abnormal, please refer to the inverter manual for the cause or contact the dealer.

4.2 Alarm description and processing

LED instructions

State	Normal/ Alarm/ Protection	ON/ OFF	RUN	ALM	Power Indicator LED						Instructions
											
Shutdown	Sleep	OFF	OFF	OFF	OFF						All OFF
Standby	Normal	ON	Flash1	OFF	According to the gas gauging						Standby mode
	Alarm	ON	Flash1	Flash3							Cell under Voltage
Charge	Normal	ON	ON	OFF	According to the gas gauging, maximum LED flash2						Maximum led flash, ALM not flash when ovp alarm
	Alarm	ON	ON	Flash3							
	OVP	ON	ON	OFF	ON						Switch to standby when there are no electric supply
	Temp/ occ/failure	ON	OFF	ON	OFF						Stop charging
Discharge	Normal	ON	Flash3	OFF	According to the gas gauging						
	Alarm	ON	Flash3	Flash3							
	UVP	ON	OFF	OFF	OFF						Stop discharging
	Temp/ ocd / ascd / failure	ON	OFF	ON	OFF						Stop discharging
Failure		OFF	OFF	ON	OFF						Stop charging/ discharging

State		Charge						Discharge					
Capacity Indicator Light		L6	L5	L4	L3	L2	L1	L6	L5	L4	L3	L2	L1
		●	●	●	●	●	●	●	●	●	●	●	●
Gas gauging	0-16.6%	OFF				Flash2	OFF				NO		
	16.6-33.2%	OFF			Flash2	NO	OFF			NO			
	33.2-49.8%	OFF		Flash2	NO		OFF		NO				
	49.8-66.4%	OFF	Flash2	NO			OFF	NO					
	66.4-83.0%	OFF	Flash2	NO			OFF	NO					
	83.0-100%	Flash2	NO				NO						
Running light		NO					Flash3						

LED flash instructions

Flash way	Light on	Light off
Flash1	0.25s	3.75s
Flash2	0.5s	0.5s
Flash3	0.5s	1.5s

Note: The LED indicator can be enabled or disabled through the upper computer, which is enabled by default

5.Communication with inverter brand

No.	Brand of Inverter
1	Sunsynk
2	Kodak

6.Packing List

No.	Item	Quantity(pcs)	Note
1	Batteries BL3.6	1	51.2V 72Ah
2	Communication cable-to inverter	1	Optional
3	Positive cable-to inverter	1	Optional
4	Negative Cable--to inverter	1	Optional
5	Parallel cable- positive	1	
6	Parallel cable- negative	1	
7	Communication parallel cable	1	
8	Ground Wire	1	
9	User Manual	1	

Warranty Claim Form

Note: Signature or Seal stamp required. Please print it, sign or stamp and then email to Distributor. Distributor shall have no obligation for unqualified application such as incorrect information or missing necessary information.

Product Model		SerialNumber(S/N)	
Company Name			
Contact Person		Contact Number	
Contact Email			
Company Address			
Name of End user			
Date of Installation			
Installation Location (Outdoors and indoors)			

Fault Description

Can the battery start up	Communication is normal	LED status (Quantity and color)

Warranty Claim Authorized Signature:

The following information must provide after faulty battery been replaced
Replacement Information

Replaced by		Replace Date	
-------------	--	--------------	--

Replacement Information Authorized signature:	
Contact Distributor :	
Distributor Name: (With stamp for confirmation)	
Contact Email:	
Telephone #:	

For further information visit www.bluemountainpv.com

@ 2021 Blue Mountain Energy LTD . The Kodak trademark , logo and trade dress are used under license from Kodak .
Blue Mountain Energy Ltd.Crown House , 27 Old Gloucester Street , London WC1N 3AX
Made in China. All information contained in this document is subject to change without notice.

