

# SPECIFICATIONS



**DP100P5S**

**SOUND-PROOF TYPE**

**DIESEL GENERATOR SET**

[www.powerlinkworld.co.uk](http://www.powerlinkworld.co.uk)

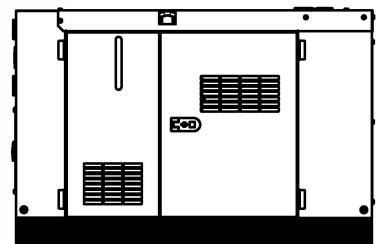

## 1 Standards & Conditions

### Design Standards

The designs and the productions are in conformity with:

- Conformance Européenne (CE)
- ISO8528-5:2005
- AS 3000-2018
- AS 3010-2017

### Environmental Operating Conditions

- Installation place: Outdoors or indoors (well ventilated).
- Ambient temperature: -25°C to 45°C. The coolant heater is needed when the temperature is below 5°C
- Humidity: Less than 80%.
- Altitude: Below one thousand (1000) meters above sea Level.

### Factory Inspection

- Inspection items.
- Protection devices working test.
- Starting ability in normal temperature.
- 50% rated power load moment capability.
- Voltage deviation and speed variation: 0%, 25%, 50%, 75%, 100%, 110% Load.

### Painting Process

- Painting process specifications and colors are based on the manufacturer's standard.
- The customer could also choose the color which the manufacturer offers.

## 2 General Features

- Perkins engine 1104C-44TAG2
- Close coupled to Stamford alternator UCI274C
- Microprocessor control module PLC-7420
- Main circuit breaker: 160A
- Rotate speed governor: Electrical governor
- Excitation system: Self excited,SHUNT
- A.V.R model: AS440
- Key switch
- Emergency stop switch
- ATS(automatic transfer switch)receptacle

- Remote run connector
- 2x12V/72AH sealed for life maintenance free battery
- Lockable battery isolator switch
- Powder coated canopy
- 45°C radiator
- Steel base frame
- Vibration isolators between the engine/alternator and base frame
- Dry type air filter
- Base fuel tank for 7 hours running
- Drain points for fuel tank
- Operation Manual / Specifications

## 3 Equipment Specification

### General technical data

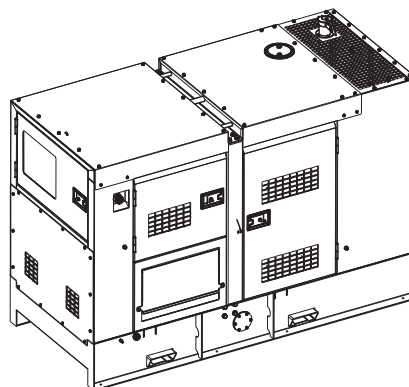

Model.....DP100P5S  
 Tank capacity..... 165L  
 Dry weight..... 1869kg  
 Noise level @7m .....70.1dB(A)  
 Dimensions L×W×H.....2500×1100×1813mm  
 Standby Power ..... 110kVA/88kW  
 Prime Power ..... 100kVA/80kW

Voltage	380V	400V	415V	440V	
Ampere	152A	144A	139A	131A	
<b>Genset Fuel Consumption</b>					
Frequency/Load	25%	50%	75%	100%	110%
50Hz (L/h)	N/A	11.2	17.1	22.6	24.9

## Power System

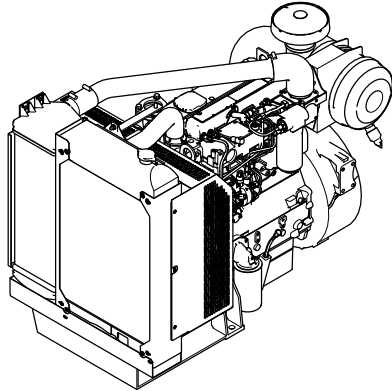

Engine Manufacturer/Brand.....	Perkins
Engine Model.....	1104C-44TAG2
Dimensions L×W×H.....	1259×721×966mm
Dry Weigh (approx.) .....	401kg
Number of Cylinders.....	4
Bore.....	105mm
Stroke.....	127mm
Displacement.....	4.4L
Compression Ratio.....	18.23
Type of Injection .....	Direct
Intake System.....	Turbocharged, air-to-air charge cooled
Intake Resistance.....	≤8.0kPa
Cooling System .....	Water cooled
Fan .....	Pusher
Battery Voltage.....	12V
Type of Fuel.....	EPA2D 89.330-96
Type of Oil .....	API-CC/SE or CCMC-D1
Oil Capacity .....	8.0L
Type of Coolant .....	Glycol mixture
Coolant Capacity.....	12.6L
Back Pressure.....	≤18kPa
Standby Power .....	103kW
Prime Power.....	93.6kW
Fuel Consumption(100%load).....	22.6L/h

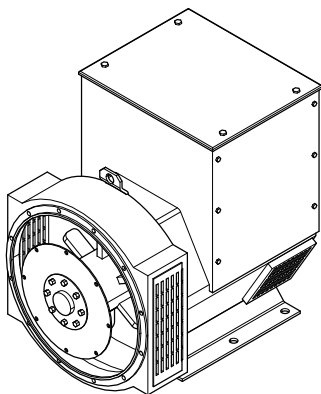

Alternator Manufacturer/Brand .....	Stamford
Alternator Model .....	UCI274C
Exciter.....	Brushless
Cooling Fan .....	Cast alloy aluminum
Windings.....	100% copper
Insulation Class .....	H
Winding Pitch.....	2/3
Terminals .....	12
Drip Proof .....	IP23
Altitude.....	≤1000m
Overspeed .....	2250 rpm
Air Flow.....	0.514m³/s(50HZ),0.617m³/s(60HZ)
Voltage Regulation .....	±1.0%
Total harmonic TGH / THCat no load < 1.5 % - on load < 5%	
Telephone Interference.....	THF<2%;TIF<50

## PLC-7420 Control System

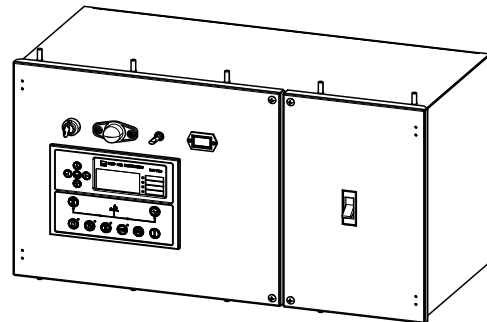

PLC-7420 is an advanced control module based on micro-processor, containing all necessary functions for protection of the genset and the breaker control. It can monitor the mains supply, and automatically start the engine when the mains is abnormal. Accurately measure various operational parameters and display all values and alarms information on the LCD. In addition, the control module can automatically shut down the engine and indicate the engine failure.

- Microprocessor control, with high stability and credibility
- Monitoring and measuring operational parameters of the mains supply and genset
- Indicating operation status, fault conditions, all parameters and alarms
- Multiple protections; multiple parameters display, like pressure, temp. etc.
- Manual, automatic and remote work mode selectable
- Real time clock for time and date display, overall runtime display, 250 log entries
- Overall power output display
- Integral speed/frequency detecting, telling status of start, rated operation, overspeed etc.
- Communication with PC via RS485 OR RS232 interface, using MODBUS protocol

## 4 Overall Dimensions

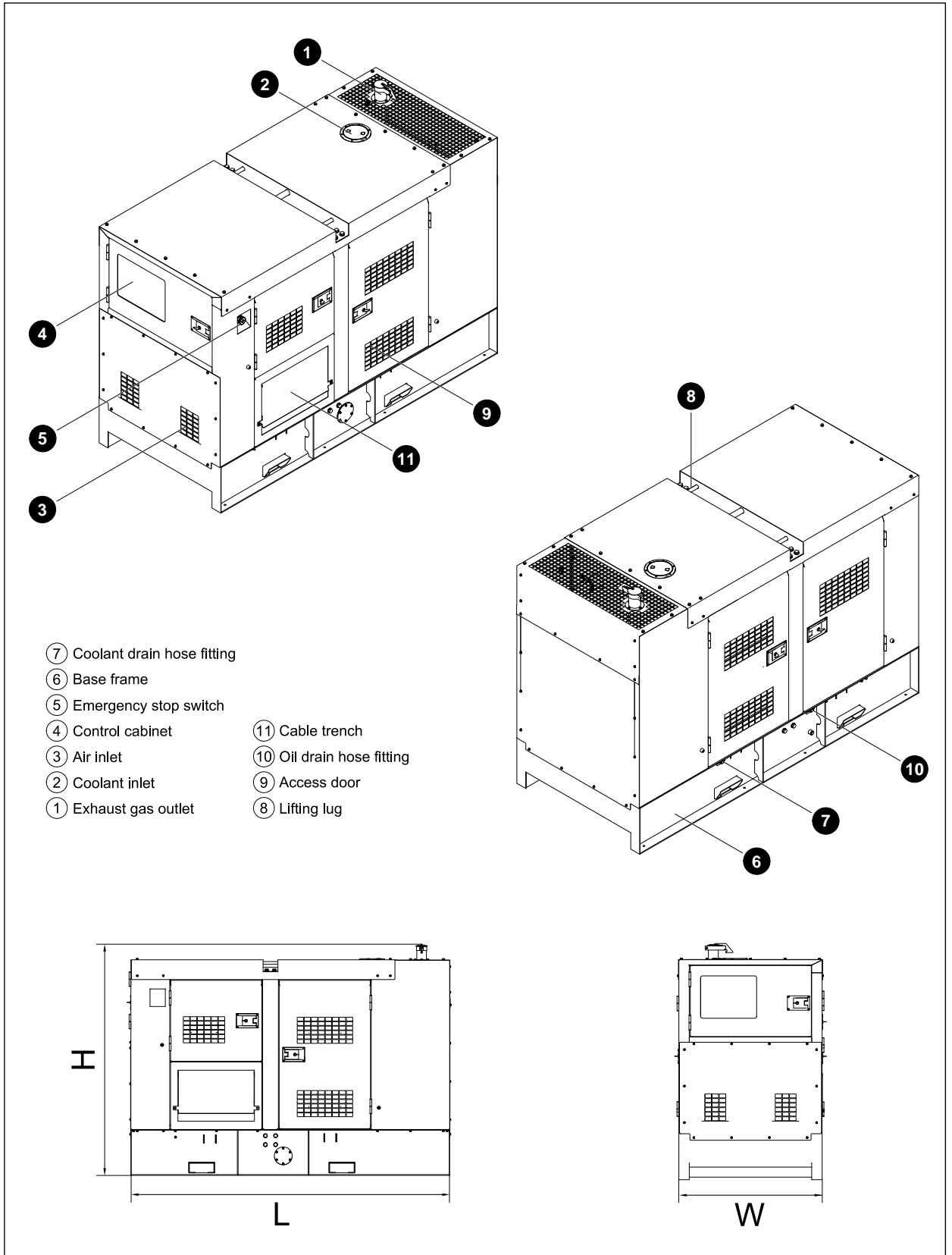

## 5 Control System

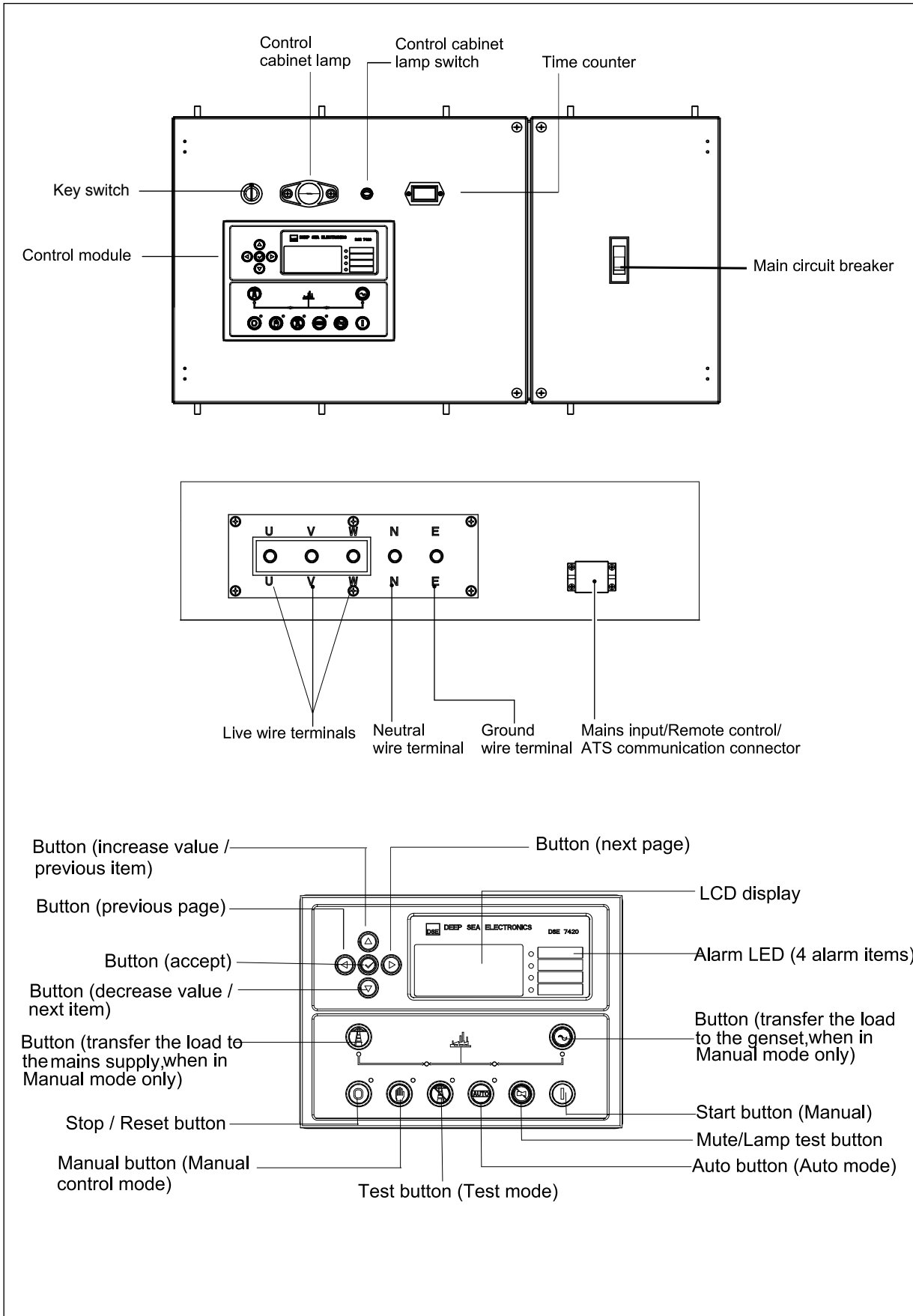

20003460
11.2022