

GR500 Roller Shutter Door Lock Data Sheet

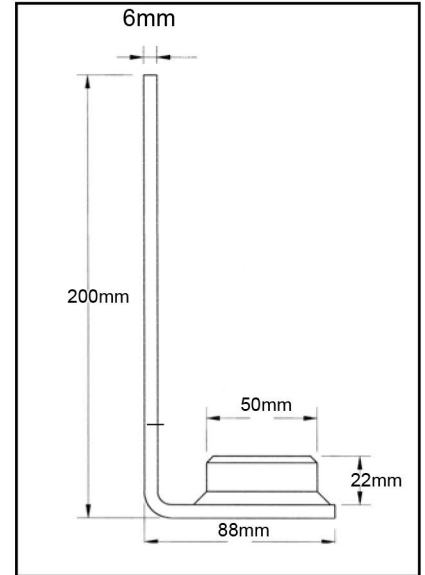

Features:

- Bolt on 'L' shaped bracket to fit to either inside or outside of roller shutter door.
- Re-inforcing plate supplied in kit to strengthen door. 75mm x 110mm x 6mm thick.
- Uses Bulldog Super Lock Bolt, no padlocks. (See separate sheet).
- M10 x 75mm coach bolts supplied for attaching bracket to door.
- Lock tube fits flush into ground, no protruding parts.
- When locked, the roller shutter door is physically held to the ground making prising of the door very difficult.
- Excavation required to fit lock tube:
depth approx 125mm, diameter approx 60mm
- Weight = 4.2kg

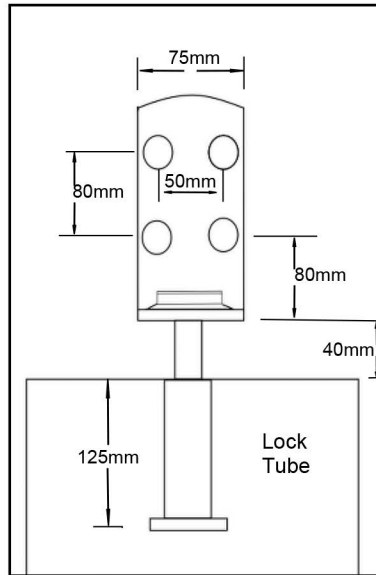
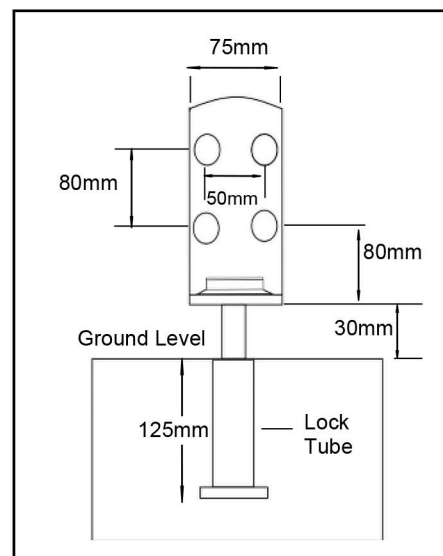
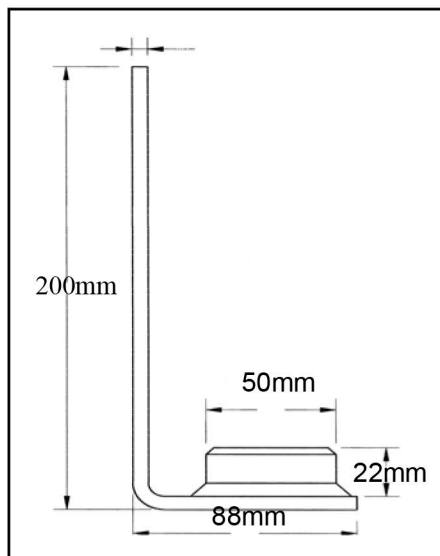

Fitting

Please note that the Lock tube has to be installed in a solid base material such as concrete slab. There will be insufficient anchorage if it is fitted into soft ground. When positioning, take care to check for buried cables or pipes.

1. Hold the angle bracket against the lower edges of the door and decide if it should be fitted on the **inside** or **outside**. In the case of some doors, your decision may be determined by the thickness of the rail which runs along the bottom of the inner framework. Although a clearance is needed between the underside of the Angle Bracket and the floor surface, it must not exceed 40mm. If the thickness of the door rail causes this clearance distance to be greater than 40mm, the lock bolt mechanism would not be able to engage in the ground tube. In this situation the bracket should be fitted to the **outside** face of the door instead.
2. When its position is established the angle bracket should be held in place and the four drilling points marked with a pencil. Usually the bracket will be fitted at a **mid point** in the lower side of a roller shutter door.
3. The four holes must now be drilled in the door material to accept the 10mm bolts. In a metal door, it will be necessary to centre-punch each hole so that the drill centres accurately. It is also advisable to drill pilot holes first with a small drill bit, enlarging them later to the finished diameter of 10mm. You may also find it helpful to complete one hole first and then to bolt the plates temporarily into position. This enables you to double-check the marking position of the other holes and to modify if necessary.
4. The angle bracket and back plate can now be finally bolted together on either side of the door using the 4 coach bolts, washers and nyloc nuts provided in the kit. Make sure that the round heads of the bolts are on the **outside** of the door to prevent unauthorised removal of the four fixings.
5. Once the bracket assembly has been fitted, it will then be used to ensure that the ground tube is fitted in a position that assures a precise location with the locking bolt.
6. A hole approximately 60mm diameter x 125mm deep should now be cut into the concrete floor. The hole can be formed quite quickly if a pneumatic hammer tool is available and these can be hired from most Tool Hire specialists.
7. A base of gravel, topped with sand should be laid in the bottom of the hole and tamped down until it is compact. This provides support for the base of the ground tube during the final stage of the installation.
8. The ground tube should now be surrounded in concrete and its final position must locate with the locking bolt. To verify its location you should close the door, insert the bolt and make certain that it matches exactly before the concrete starts to set. This final check will also ensure that the ground tube has been cast in a **vertical** position. Fit the yellow dust cap to prevent concrete or dirt damaging the lock.
9. An hour or so later you can carefully remove the bolt, open the door and trowel-off the surface to match the rest of the floor slab. However, it is recommended to close the door and to re-engage the bolt after this has been done. The concrete should then be left for **at least 2 days** to set completely - although exact setting time varies according to the weather.

Lock Lubrication.

IMPORTANT - To ensure free movement of the lock, spray lock mechanism & ball bearings with WD40 (or equivalent) minimum every four months.