

**ID-Nr. 39354-247**  
**Model IO90.078.059.057.U9.S**



**BATTERY CHARGE charging cabinet ION-CHARGE-90**  
**Model IO90.078.059.057.U9.S, body colour anthracite grey (RAL 7016), with drawer in gentian blue (RAL 5010)**

**Safe storage and charging of lithium-ion batteries**

**Function / construction:**

- **User-friendly:** drawer remains open in any position, interior of drawer completely visible – access to all containers
- **Safe:** drawer fitted with earthing wire incl. clamp as standard, seal welded sump, drawers are self-closing in the event of fire
- **No unauthorised use:** drawer lockable with cylinder lock and locking state indicator (red/green)
- **Easy transport:** integrated transport base for internal transportation
- **All-around protection:** 90 minute fire protection from outside to inside (type 90 / type tested in accordance with EN 14470-1) and for more than 90 minutes fire resistance for fires from inside to outside



Dimensions	
Width (external)	593.00 mm
Depth (external)	574.00 mm
Height (external)	780.00 mm
Width (internal)	470.00 mm
Depth (internal)	452.00 mm
Height (internal)	582.00 mm

The available internal dimensions can vary depending on the interior equipment package.

Weight / Load	
Weight without interior equipment	130 kg
Distributed load	461.00 kg/m <sup>2</sup>
Maximum load	300 kg

Ventilation	
Frequency	50/60 Hz
Nominal voltage	230 V

Outlet strips (Charging power)	
Fuse (1-phase)	16 A
Power max. (1-phase)	3,68 kW

Colouring / Surface finish	
Body colour code	RAL 7016
Body colour	anthracite grey
Body surface finish	textured
Door / Drawer colour code	RAL 5010
Door / Drawer colour	gentian blue
Door / Drawer surface finish	textured

General Information	
Number of drawers	1
Entry width transport base	548 mm
Entry height transport base	95 mm
Customs tariff number	94032080

**Front view**

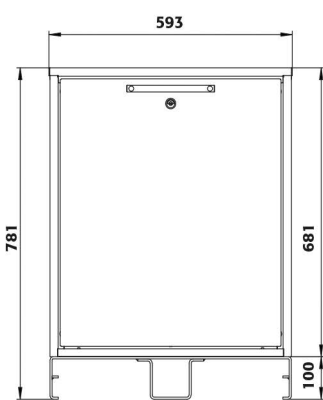

**Side view**

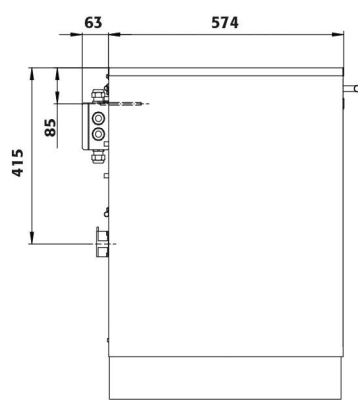

**Sectional view**

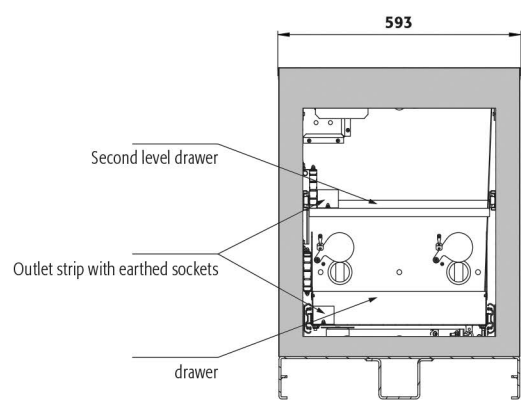

**Top view**

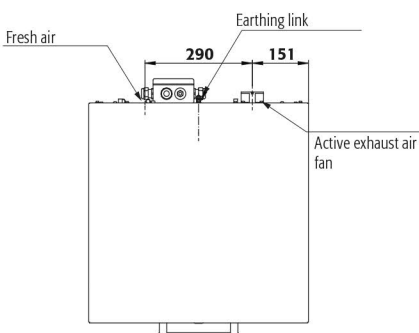

**Fire and Safety Centre**

**Available From:**

Fire and Safety Centre  
 15 Atkinsons Way, Foxhills Industrial Estate  
 Scunthorpe, North Lincolnshire, DN15 8QJ  
**Tel:** 01724 281044 **Web:** [www.fireandsafetycentre.co.uk](http://www.fireandsafetycentre.co.uk)  
**Email:** [sales@fireandsafetycentre.co.uk](mailto:sales@fireandsafetycentre.co.uk)