

INSTRUCTION MANUAL

TATSOUL 370-S

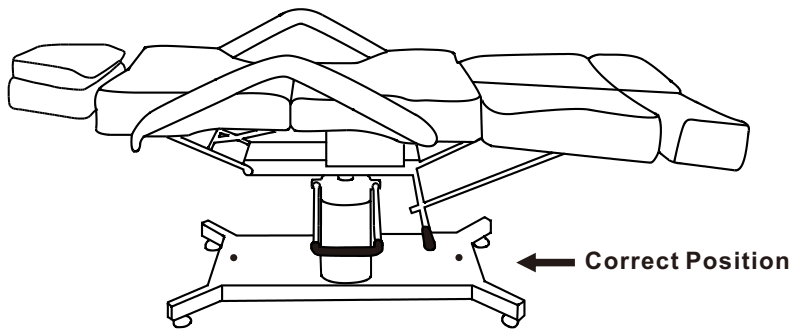

When a client is getting on the chair, **ALWAYS** have the chair locked and the bed set in a parallel position to the base as shown.

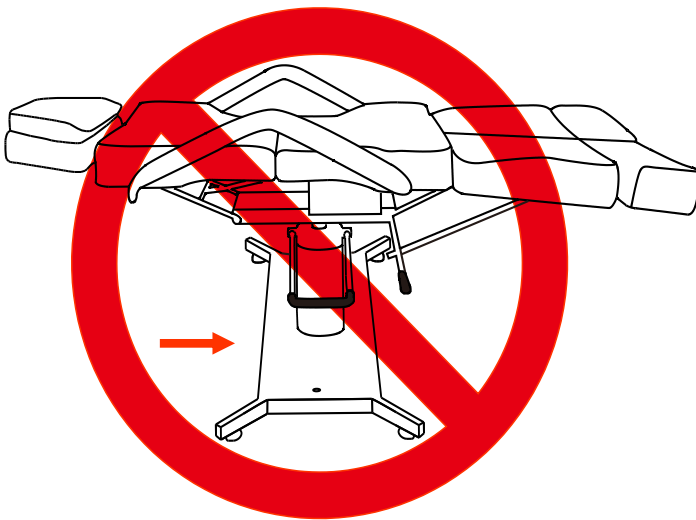

CONTENTS

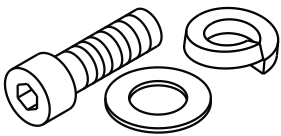
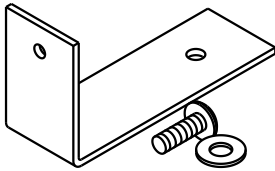
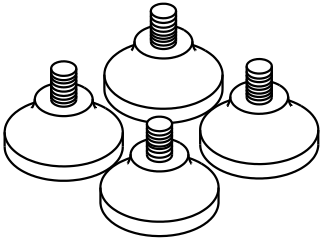
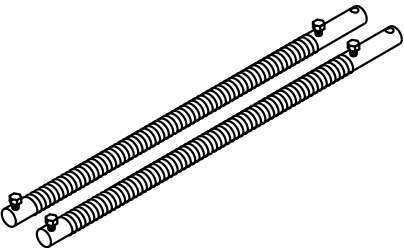
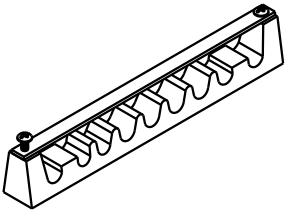
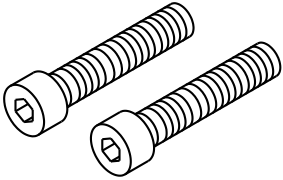
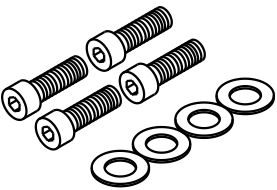
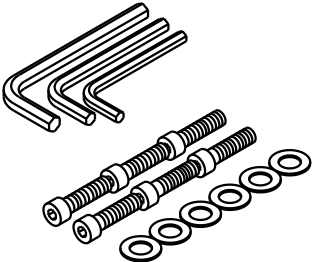
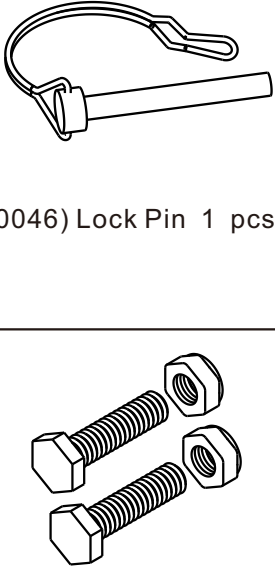
 <p>P1(60027) Connector Bolt M10x25 1 pcs P2(60028) Connector Washer φ 10X20X1.5 1 pcs P3(60029) Split Lock Elastic Gasket φ 10 1 pcs</p>	 <p>S1 (60030) Spring Hook 1 pcs S2 (60031) Connector Washer φ 6x13x1 1 pcs S3 (60032) Hook Screw M6x16 1 pcs</p>	 <p>W (60040) Adjustable Foot Pegs φ 48x10x30 4 pcs</p>
 <p>Y (60042) Leg Bars 2 pcs</p>	 <p>X2 (60037) Back Teeth 1 pcs</p>	 <p>X1(60041) Back Teeth Bolts M8x45 2 pcs</p>
 <p>T1 (60033) Base Bolt M8x20 4 pcs T2 (60034) Base Washer φ 8X17X1.5 4 pcs</p>	 <p>U1 (60035) Top Frame Bolt M8x30 6 pcs U2 (60036) Top Frame Washer φ 8X17X1.5 6 pcs Z1 (60043) M5 Allen Wrench 1 pcs Z2 (60044) M6 Allen Wrench 1 pcs Z3 (60045) M8 Allen Wrench 1 pcs</p>	 <p>Z4 (60046) Lock Pin 1 pcs</p> <p>O1 (60047) Connector Bolts M10x40 2 pcs O2 (60048) Since The Lock Nuts M10 2 pcs</p>

ASSEMBLY INSTRUCTIONS

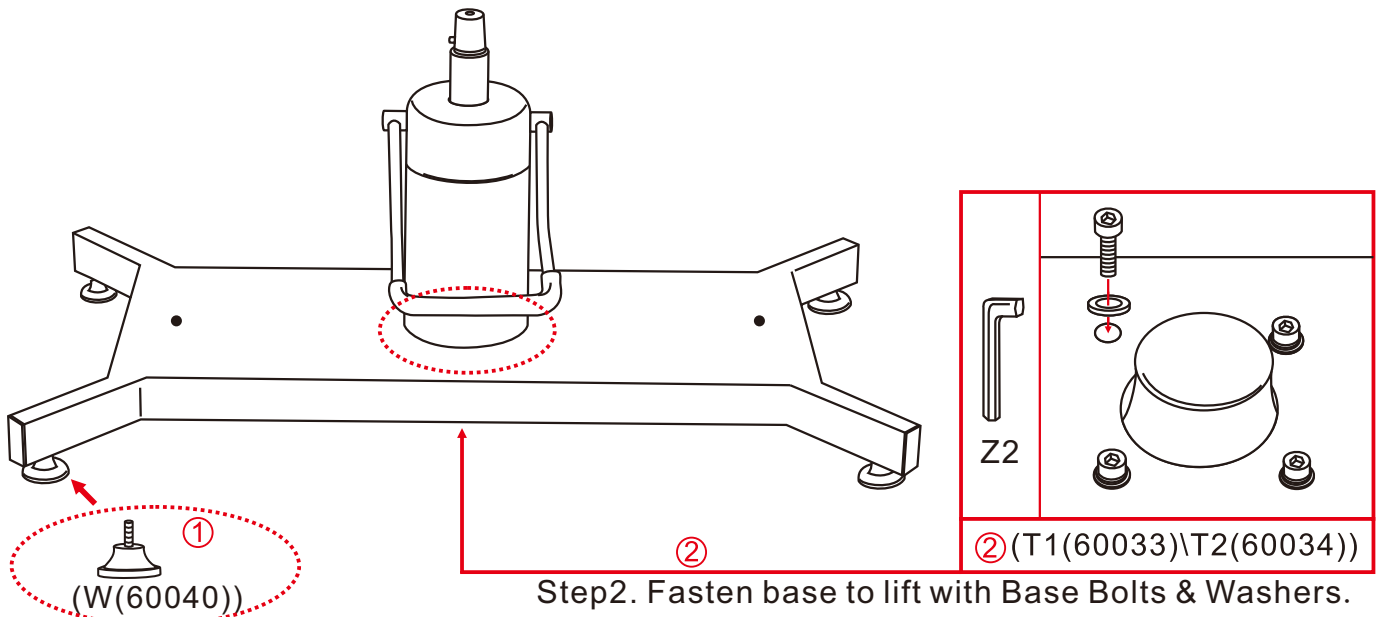

Step1. Screw foot pegs into base.

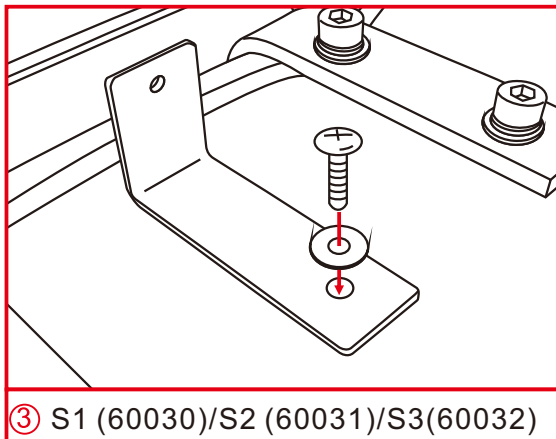
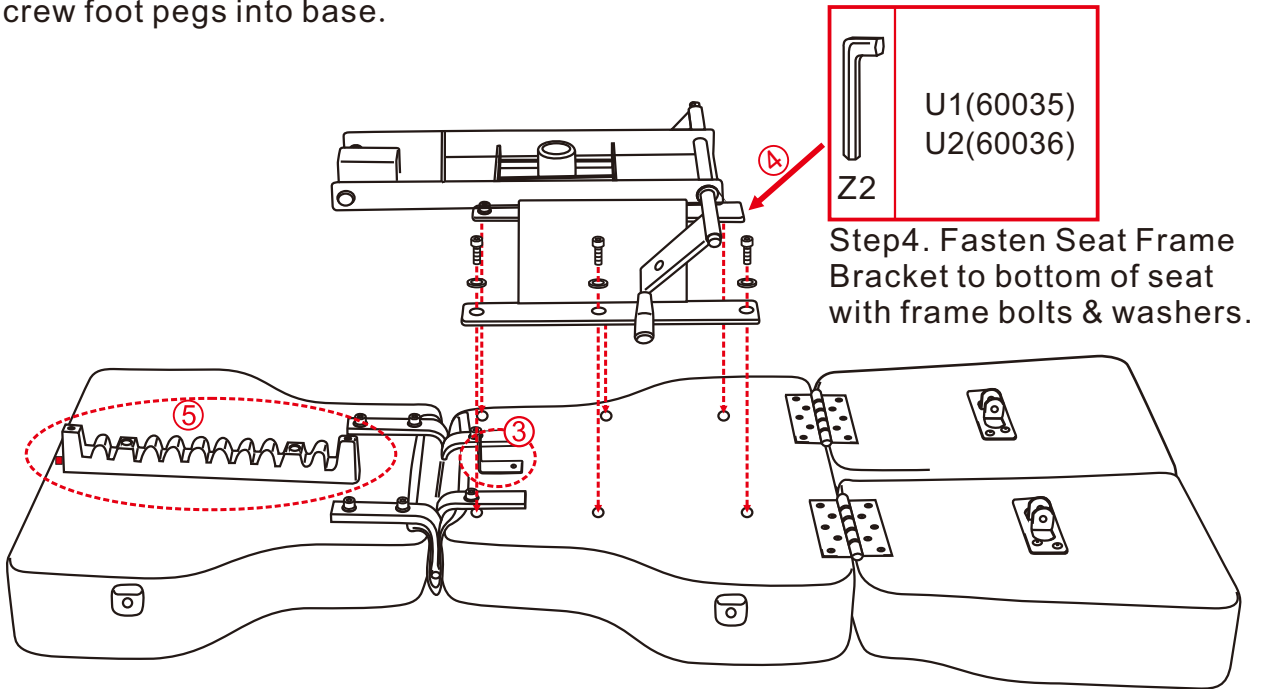

Step3. Fasten Spring Hook Bracket to bottom of seat with spring hook bracket bolt & washer.

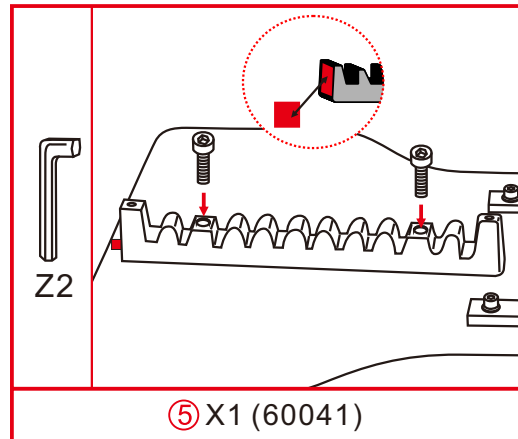

Step5. Fasten Back Teeth to seat back with back teeth bolts.

ASSEMBLY INSTRUCTIONS

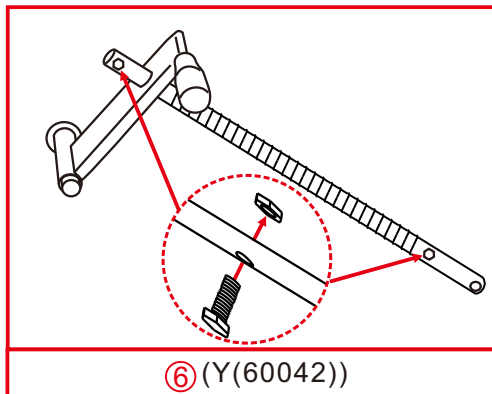
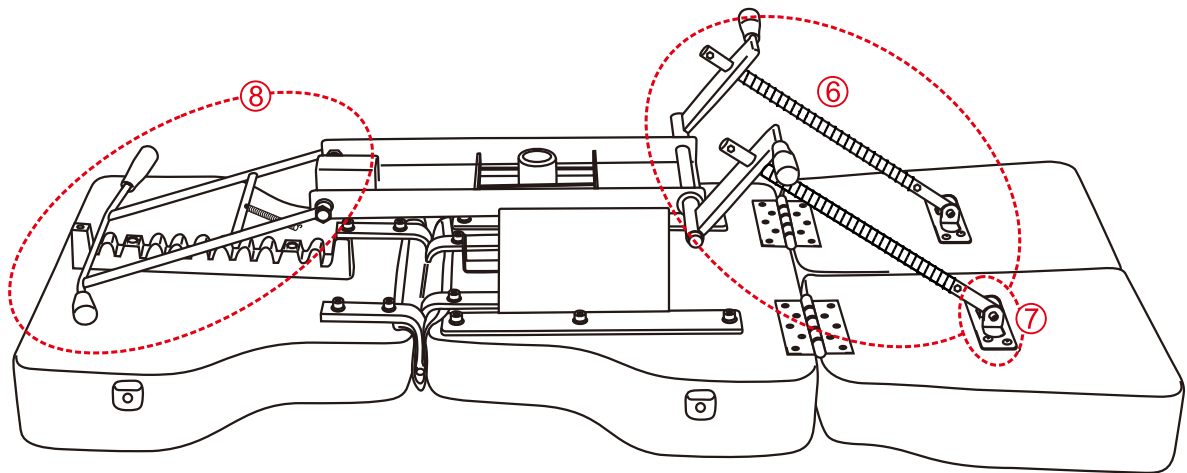

⑥ (Y(60042))

Step6. Insert Leg Rest Bars into handle of seat frame and fasten stopper bolt and washer.

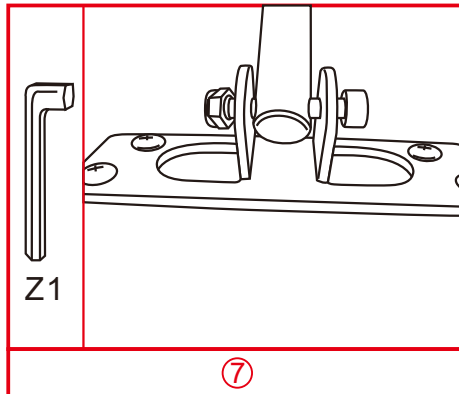

⑦

Step7&8. Tighten Hinge Bolt on leg rest bars.

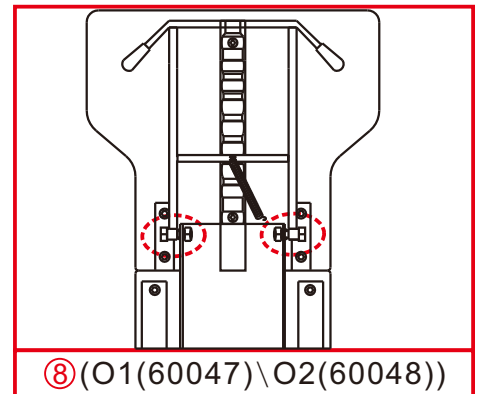

⑧ (O1(60047) \ O2(60048))

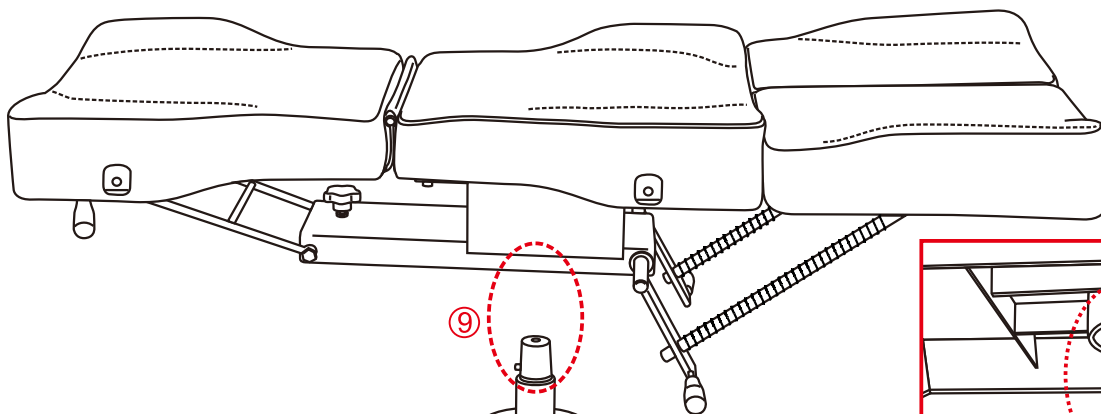

⑨

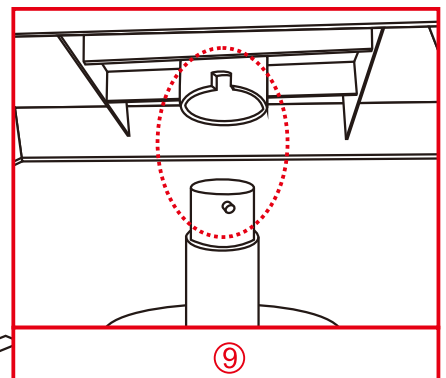

⑨

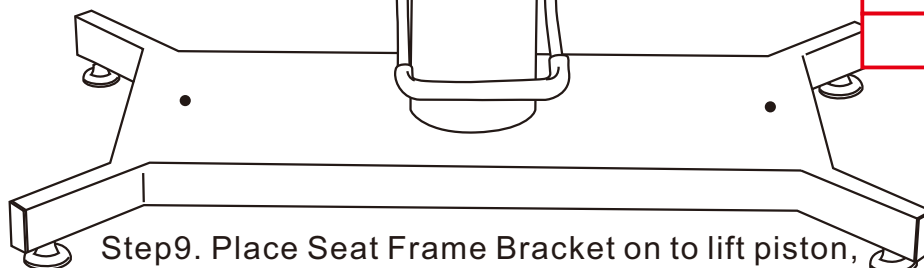

Step9. Place Seat Frame Bracket on to lift piston, aligning seat frame notch with piston peg.

ASSEMBLY INSTRUCTIONS

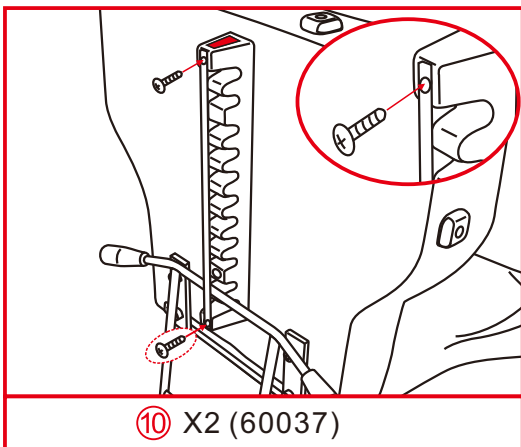
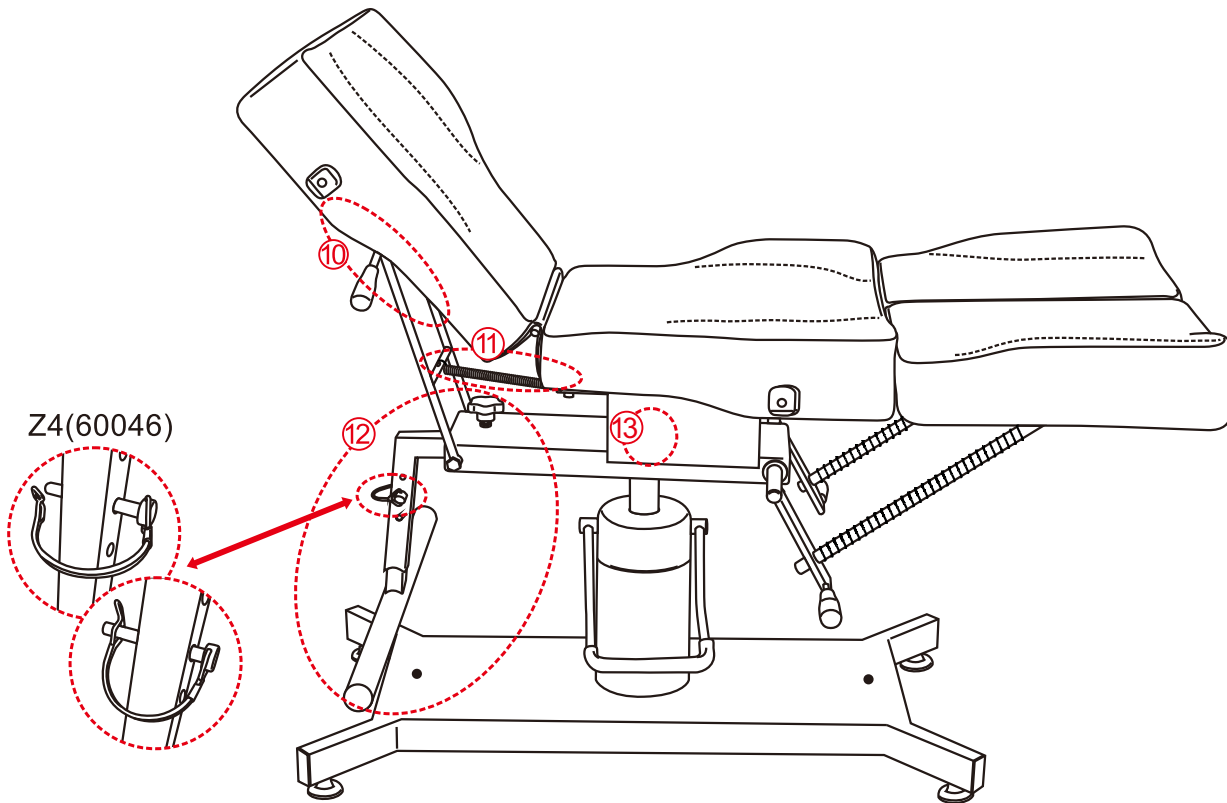

⑩ X2 (60037)

Step 10. Insert Back Adjustment Bar into Back Teeth, then fasten back teeth crossbar over top with cross bar mounting screws.

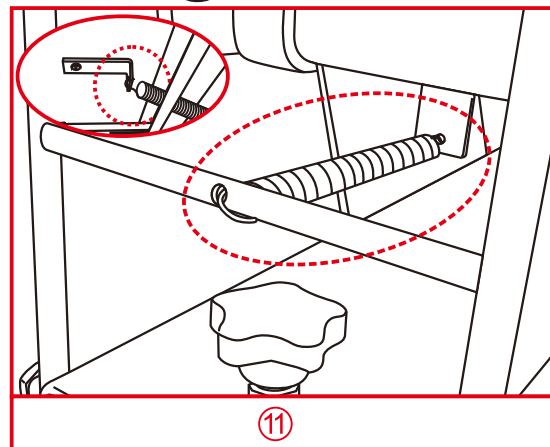

⑪

Step 11. Attach Spring to Seat Back Adjustment Bar and Spring Hook Bracket.

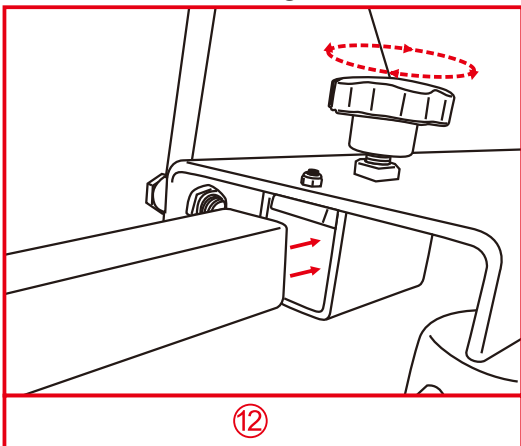

⑫

Step 12. Insert Adjustable Foot Rest into seat frame bracket and tighten lock knob. Insert locking pin into foot rest height adjustment holes.

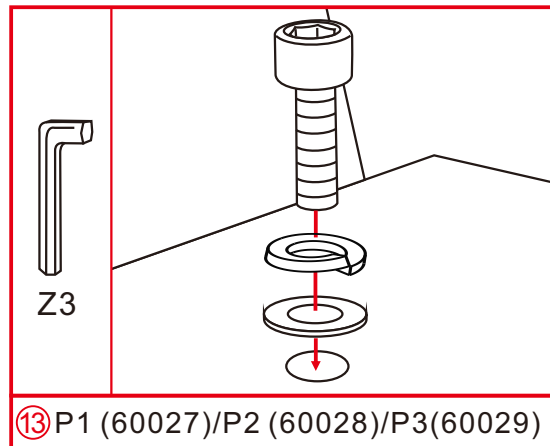

⑬ P1 (60027)/P2 (60028)/P3(60029)

Step 13. Fasten Seat Frame Bracket to Lift Piston, using connector bolt with washer and gasket.

OPERATING INSTRUCTIONS

HEADREST IS ADJUSTABLE AND REMOVABLE

ARM REST IS ADJUSTABLE AND REMOVABLE

LEG REST EXTENDER IS ADJUSTABLE AND REMOVABLE

ADJUSTABLE FOOT REST

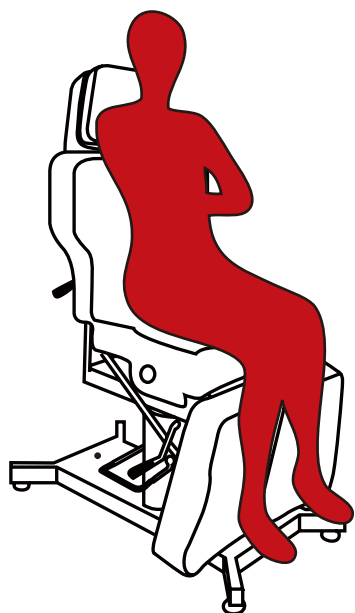
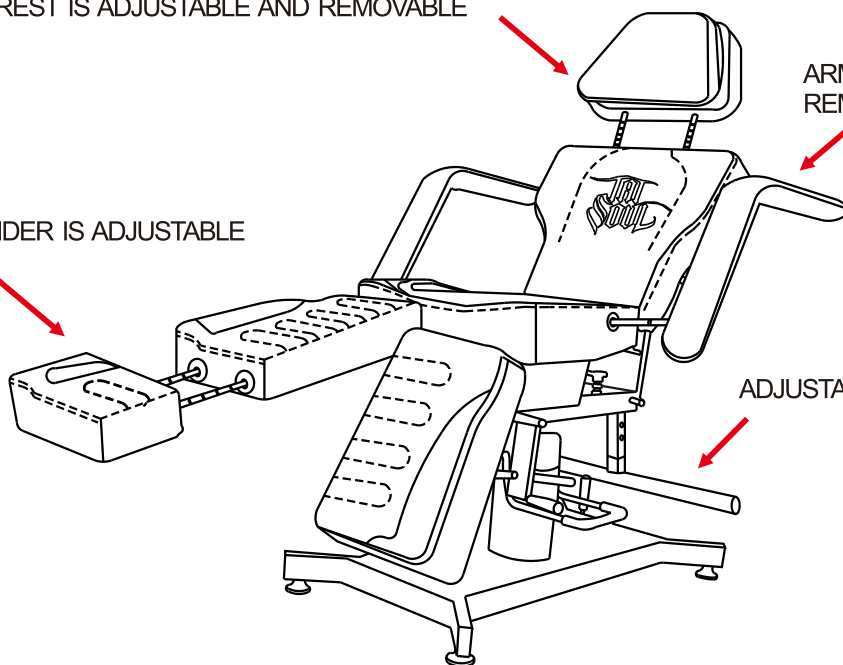

CHAIR POSITION



STRADDLE POSITION

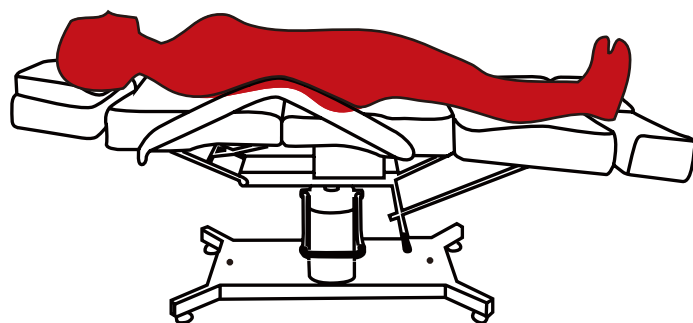

BED POSITION

WARNING:

DO NOT POSITION CHAIR IN BED FORMAT PERPENDICULAR TO LONG PORTION OF BASE!

OPTIONAL ACCESSORIES

Face Cradle

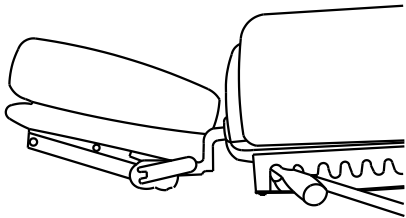

TATSoul Landing Gear Retractable Wheels

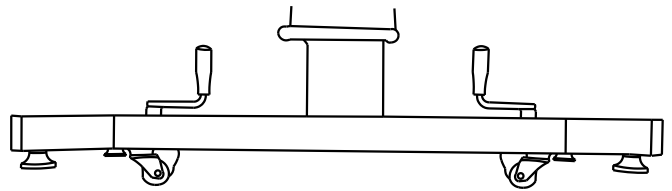

370 Wing Extensions

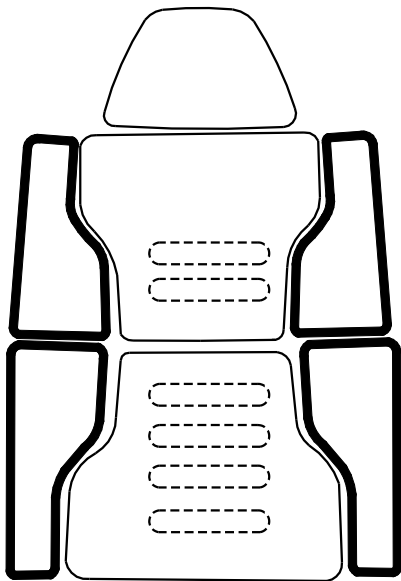

370 Protective Covers



VINYL AFTERCARE

1. Use soft cleaning implements. Only clean your vinyl seats with soft sponges, dish cloths, and soft-bristled brushes. This will ensure your vinyl seats last for many years. Using steel wool, sharp cleaning tools, or similarly abrasive cleaning implements could cause your vinyl seating to tear.

2. Wash your vinyl with soapy water. Mix a small amount of mild dish soap with warm water until the mixture is sudsy. Dip a soft-bristled brush or soft cloth in the water. Scrub the vinyl seats until clean.

3. Do not use abrasive cleaning compounds. Undiluted bleach, for instance, is too caustic to use on vinyl. Over time, cleaning your vinyl seats with bleach will cause them to break down.^[6] Likewise, avoid cleaning compounds containing:^[7]

- concentrated detergents
- silicone oils
- waxes
- petroleum distillates
- dry cleaning fluids
- solvents
- acid-based cleaners

CONTACT INFORMATION:

If you have any questions about our products, feel free to contact us via email or by phone. We are available via telephone during PST business hours. We try to respond to emails within a few hours of their receipt, even during evenings and weekends.

General Information:

Email: sales@tatsoul.com

Fax: 1-800-768-5643

Sales:

Email: sales@tatsoul.com

Telephone: 1-888-TAT-SOUL
(1-888-828-7685) Option 1

Technical Support:

Email: support@tatsoul.com

Telephone: 1-888-TAT-SOUL
(1-888-828-7685) Option 2