

User's Manual

INFIRAY OUTDOOR

BOLT TH50C V2

Bolt Action Optimized Thermal Rifle Scope



WARNING! ITAR REQUIREMENTS

These products may be subject to export and foreign trade control laws of the United States and may not be exported without prior approval of the U.S. Department of State. Learn more at irayusa.com/ITAR.

FCC ID 2AYGT-2D00

This device complies with part 15 of the FCC Rules. Operation is subject to the following two conditions: (1) This device may not cause harmful interference, and (2) this device must accept any interference received, including interference that may cause undesired operation.

CAUTION: Changes or modifications not expressly approved by IRayUSA could void the user's authority to operate the equipment.

NOTE: This equipment has been tested and found to comply with the limits for a Class B digital device, pursuant to part 15 of the FCC Rules. These limits are designed to provide reasonable protection against harmful interference in a residential installation. This equipment generates, uses and can radiate radio frequency energy and, if not installed and used in accordance with the instructions, may cause harmful interference to radio communications. However, there is no guarantee that interference will not occur in a particular installation. If this equipment does cause harmful interference to radio or television reception, which can be determined by turning the equipment off and on, the user is encouraged to try to correct the interference by one or more of the following measures:

- Reorient or relocate the receiving antenna.
- Increase the separation between the equipment and receiver.
- Connect the equipment into an outlet on a circuit different from that to which the receiver is connected.
- Consult the dealer or an experienced radio/TV technician for help.

This device was tested for typical body-supported operations and use. To comply with RF exposure requirements, a minimum separation distance of 0.5cm must be maintained between the user's body and the handset, including the antenna. Third-party belt-clips, holsters, and similar accessories used by this device should not contain any metallic components. Body accessories that do not meet these requirements may not comply with RF exposure requirements and should be avoided. Use only the supplied or an approved antenna.

WARNING: CHOKING HAZARD

Children under 3 years old can choke or suffocate on small parts of this product. This product is not a toy; keep out of reach of children.

TABLE OF CONTENTS

1. Overview	2
2. Features	2
3. Tech Specs	3
4. Accessories	4
5. Components and Controls	5
6. Description of Control Buttons & Shortcuts ...	6
7. Quick Start Guide	8
8. Charging the Built-in Battery Pack	10
9. Installing an Auxiliary Battery	11
10. Battery Status Indicators	12
11. Switching the Battery Power Supply.....	13
12. Battery Safety Precautions	13
13. External Power Supply	14
14. Mounting the BOLT TH50C V2.....	15
15. Operating Instructions	16
16. Zeroing the BOLT TH50C V2.....	22
17. Non-Uniformity Correction	23
18. Photography and Video Recording	24
19. Accessing the Internal Memory	26
20. Using the InfiRay Outdoor App	27
21. Digital Zoom.....	28
22. Picture in Picture (PIP).....	28
23. Bluetooth Laser Rangefinder	29
24. Stadiametric Rangefinder	29
25. Ultra-clear Mode	30
26. Main Menu Options and Descriptions	30
27. Basic Inspection	46
28. Basic Maintenance	46
29. Warranty.....	47
30. General Troubleshooting	48
31. Notes	50

1. OVERVIEW

The InfiRay Outdoor BOLT TH50C V2 expands on the success of the TH50C with the addition of improved audio recording and an optional Bluetooth laser rangefinder module. InfiRay's industry-leading 12 μm 640 \times 512 Micro II sensor, 1.03-inch large-format 2560 \times 2560 resolution display, and Shutterless Calibration feature are now more powerful than ever, while still maintaining the proven combination of a manual focus lens, dual battery design, and tactile control turret. The BOLT TH50C V2's traditional look and flexibility of a 30 mm ring mounting interface also guarantee the perfect fit on your favorite hunting rifle.

2. FEATURES

- 12 μm iRay Micro II thermal sensor
- 1.03-inch large-format AMOLED display with ultra-high 2560 \times 2560 resolution
- Aluminum alloy housing
- 2400-yard detection range
- Stepped digital zoom from 1.0 \times to 4.0 \times
- Dual power supply solution for extended operation
- Multiple zero profiles and ranges
- Traditional 30 mm diameter housing design
- Compatible with ILR-1200-1 Bluetooth Laser Rangefinder Module (optional/not included)
- Stadiametric rangefinder
- High frame frequency: 50hz
- Built-in 32 GB storage to support image capture and video recording
- Built-in Wi-Fi module
- Mobile device App compatible
- Built-in digital compass and gravity sensor
- Multiple reticle types and color options
- Ultra-clear mode for advanced image detail
- Picture in Picture (PIP)
- Defective pixel correction
- Extended eye relief
- Cold and warm image temperature options
- User-friendly interface

3. TECH SPECS

BOLT	TH50C V2
SENSOR	
Resolution	640 \times 512
Pixel Size	12 μm
Frame Rate	50hz
Image Processing	MATRIX III
Core	InfiRay Micro II 640
OPTICS	
Objective Lens	50 mm f/1.1
Magnification	3.5 \times
Digital Zoom	4 \times , Stepped
Field of View	8.8 $^{\circ}$ \times 7.0 $^{\circ}$
Detection Range	2400 Yards
Display Type	1.03-inch Large-format AMOLED
Display Resolution	2560 \times 2560
Color Palettes	White Hot, Black Hot, Red Hot, Color, Highlight
Reticle Types	7 (2 Dynamic, 5 Static)
Reticle Colors	Black, White, Red, Green
Mounting System	30 mm Rings
P.I.P	Yes
Rangefinder	Stadiametric, Bluetooth ILR-1200-1 LRF (Optional/Not Included)
Eye Relief	50 mm
Diopter Range	-5 to +3.5
ELECTRONICS	
Onboard Recording	Video and Image
Onboard Storage	32 GB
Wireless Connectivity	Video and Image via App
Data/Power Connector	USB-C
Power Supply	USB-C External, Built-In Battery Pack (8+ Hours), 18500 Battery (2+ Hours), 18650 Battery (3.5+ Hours)
Start Up Time	<10 Seconds, Instant from Standby
PHYSICAL	
Size	14.5" \times 3.34" \times 2.95"
Weight	33.15 Oz
ENVIRONMENTAL/WARRANTY	
Warranty	5 Years
Housing Material	T-6061 Aluminum
Ingress Protection	IP67
Operation Temperature	-4 $^{\circ}\text{F}$ \sim 122 $^{\circ}\text{F}$
Max. Recoil	1000 g/s ² (300 Win./7mm Mag)

4. ACCESSORIES

The BOLT TH50C V2 ships with everything you need to get out and hunt. The included items are as follows:

- BOLT TH50C V2 Thermal Imaging Rifle Scope
- Objective lens cap
- Eyeshade
- 30mm ring mounts for Picatinny rail
- Soft case
- USB-C cable for data/video
- Wall adapter
- Lens cloth
- User manual



Optional accessories, such as the IRAY-AC96 ILR-1200-1 Bluetooth Laser Rangefinder Module, IRAY-AC30 18500 Battery for BOLT, and IRAY-AC37 18650 Battery Extender, as well as various replacement accessories, including cables and factory mounts, are available for purchase. Contact 800-769-7125 or irayusa.com/support.

5. COMPONENTS AND CONTROLS

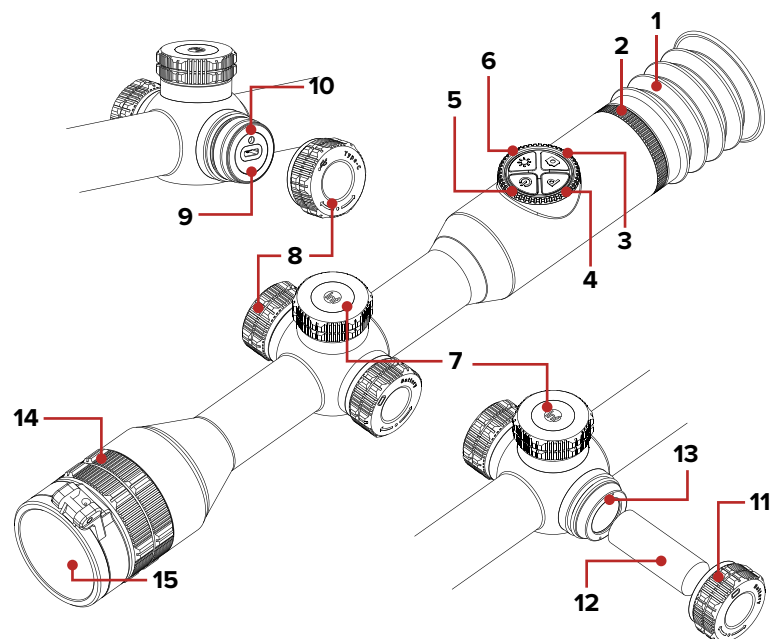

- 1 Eyeguard
- 2 Eyepiece Diopter Adjustment Ring
- 3 Photo Button
- 4 Palette Button
- 5 Power Button
- 6 Brightness Button
- 7 Tactile Control Turret
- 8 USB-C Port Cover
- 9 USB-C Port
- 10 LED Status Indicator
- 11 Auxiliary Battery Cover
- 12 18500/18650 Auxiliary Battery (optional/not included)
- 13 Auxiliary Battery Compartment
- 14 Objective Lens Focus Ring
- 15 Objective Lens Cap

6. DESCRIPTION OF CONTROL BUTTONS AND SHORTCUTS

Power Button 		
Current Screen / Menu or Device Status	Short Press	Long Press
Device off	---	Power on the device
Home screen	Perform a manual non-uniformity correction	Power off the device; enter standby mode
In standby mode	Exit standby mode	---
Main menu	Return to previous without saving changes	---
Defective pixel correction interface	Add or remove defective pixel from the "to be corrected" list	---
Reticle zeroing interface	Exit interface and return the reticle to the last saved zero position	---

Palette Button 		
Current Screen / Menu	Short Press	Long Press
Home screen	Switch the color palette	Turn PIP window on / off

Brightness Button 		
Current Screen / Menu	Short Press	Long Press
Home screen	Adjust the screen brightness	Enter / exit the stadiametric rangefinder

Photo Button 		
Current Screen / Menu	Short Press	Long Press
Home screen	Take a photo	Start / stop recording video

Photo + Palette Button 		
Current Screen / Menu	Short Press	Long Press
Reticle zero interface	---	Freeze image to keep reticle centered on aiming point; press again to clear frozen image

Photo + Brightness Button 		
Current Screen / Menu	Short Press	Long Press
Home screen	---	Activate / deactivate the reticle
Reticle zero interface	---	Return reticle to the center

Control Turret			
Current Screen / Menu	Short Press	Long Press	Rotate
Home screen	Enter quick menu	Enter main menu	Adjust digital zoom level
Quick menu	Adjust parameters for a menu item	Return to home screen	Switch menu options; move menu cursor; move reticle position Clockwise: Move left / down Counterclockwise: Move right / up
Main menu	Confirm changes; open the submenu	Save changes and exit to home screen	
Reticle zero interface	Switch between X and Y	Save changes and exit to home screen	
Defective pixel correction interface	Switch between X and Y	Save changes and exit to home screen	

NOTE: Consult the manual that comes with your ILR-2000-1 Laser Rangefinder Module (optional/not included) for rangefinder shortcuts.

7. QUICK START GUIDE

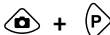
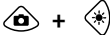
Step 1: Preparing to Use the BOLT TH50C V2



1. Compare the box contents to the accessories list and examine each for any shipping damage. See **Accessories** on page 4.
2. Check the lens to ensure there are no smudges or dirt present. Clean with the included lens cloth, as needed.
3. Charge the built-in battery pack before using the TH50C V2 for the first time. See **Charging the Built-in Battery Pack** on page 10.
4. Install the eyeguard (1).
5. Mount the TH50C V2 to the weapon using the included 30 mm rings. See **Mounting the BOLT TH50C V2** on page 15.

Step 2: Turn On and Adjust the Focus

1. Open the objective lens cap (15).
2. Long press the **Power**  **Button** for 2 seconds to power on the TH50C V2. The InfiRay logo will appear.
3. Rotate the diopter adjustment ring (2) of the eyepiece until the interface icons are clearly visible.
4. Rotate the objective lens focus ring (14) to focus on the object being observed.

WARNING: Do not point the objective lens toward intense energy sources, such as the sun. This may render the electronic components inoperative. The warranty does not cover damage caused by improper operation.



Step 3: Activate and Customize the Reticle



The reticle may be inactive when the TH50C V2 is powered on for the first time. To activate the reticle, press and hold the **Photo**  and **Brightness**  **Buttons** at the same time for at least 15 seconds.

1. From the home screen, short press the **Control Turret** to enter the quick menu (see **Using the Quick Menu** on page 20):
 - a. Select the reticle type, from 1–6.
 - b. Select the reticle color, white, black, red, or green.

Step 4: Adjust the Image Settings

From the home screen:

1. Short press the **Palette**  **Button** to set the color palette to white hot, black hot, red hot, highlight, or color.
2. Short press the **Brightness**  **Button** to adjust the screen brightness, from 1–5. The screen brightness  icon and the selected brightness level appear at the bottom of the screen.

3. Short press the **Control Turret** to enter the quick menu to adjust the image sharpness, from 1–5. See **Using the Quick Menu** on page 20.
4. Short press the **Power**  **Button** to perform a non-uniformity correction, as needed. See **Non-Uniformity Correction (NUC)** on page 23.
5. Rotate the **Control Turret** to zoom in and out on the observed object. See **Digital Zoom** on page 28.
6. Long press the **Palette**  **Button** to turn on the PIP window. See **Picture in Picture (PIP)** on page 28.
7. Long press the **Control Turret** to enter the main menu to:
 - a. Turn on Ultra-clear mode to enhance the image contrast in inclement weather. See **Main Menu > Ultra-clear** on page 31.
 - b. Set the image temperature to warm or cold. See **Settings Menu > Image Hue** on page 44.

Step 5: Adjust Rifle Scope Settings

1. From the home screen, long press the **Control Turret** to enter the main menu to:
 - a. Turn on the digital compass. See **Main Menu > Compass** on page 32.
 - b. Turn on the gravity sensor. See **Main Menu > Gravity Sensor** on page 32.
 - c. Change the non-uniformity correction (NUC) mode to automatic, manual, or background. See **Main Menu > Calibration** on page 37.
 - d. Calibrate the digital compass. See **Main Menu > Compass Calibration** on page 41.
 - e. Set the date and time. See **Settings Menu > Date** and **Settings Menu > Time** on page 42.
 - f. Set the units of measurement to meters or yards. See **Settings Menu > Units of Measure** on page 43.

Step 6: Zero the TH50C V2

1. Zero the rifle scope following the instructions in **Zeroing the BOLT TH50C V2** on page 22.
 - a. Select the zeroing profile, A, B, or C. See **Main Menu > Zeroing Profile** on page 33.
 - b. Select, or customize, a preset zero distance that matches the target distance. See **Reset Zeroing Distance Menu > Zero Distance** on page 34.
 - c. Zero the reticle. See **Reset Zeroing Distance Menu > Reticle Zeroing** on page 34.

8. CHARGING THE BUILT-IN BATTERY PACK

The BOLT TH50C V2 has a dual power supply: a built-in rechargeable li-ion battery pack and an optional auxiliary battery (18500 or 18650 with adapter; batteries not included). The dual battery system supports a run time of 8 hours out of the box and 10+ hours when using an auxiliary battery.

The built-in battery pack is not removable or replaceable. Please ensure the battery pack is fully charged before the first use.

To charge the battery pack:

1. Remove the USB-C port cover (8) by turning it counterclockwise.
2. Connect the smaller USB-C end of the data cable (16) to the USB-C port (9).
3. Connect the standard USB end of the data cable to:
 - a. Any standard USB 3.0 port on a laptop/computer; OR
 - b. A 5V–2A USB power adapter and plug the power adapter into an electrical outlet.
4. While charging, the LED status indicator (10) above the USB-C port will turn red. When the indicator LED turns green, the battery is fully charged.

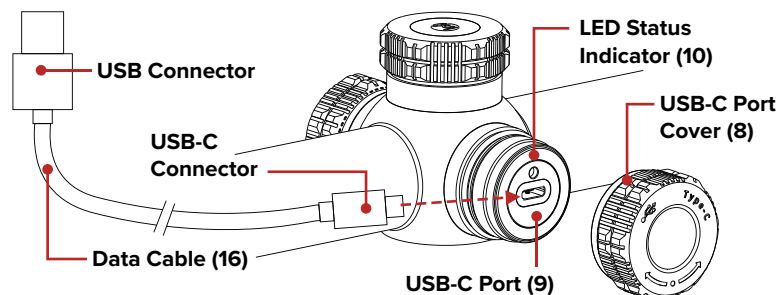

5. When fully charged, disconnect the data cable from the USB-C port and replace the USB-C port cover.
 - a. It takes about 3–5 hours to charge the battery. Do not overcharge.
 - b. See **Battery Status Indicators** on page 12 for additional battery information.

WARNING: Never charge the battery pack with a USB adapter that is greater than 5V–2A.

NOTES:

- You may charge and operate the TH50C V2 at the same time.
- When the battery status icon turns red and only one bar remains, charge the battery right away to avoid over-discharge and a reduction in battery capacity or service life.
- When the built-in battery pack is charging, a charging ⚡ icon appears above the battery status indicator in the bottom-right corner of the screen.
- Only the built-in battery pack will be charged while connected via the USB-C port.

9. INSTALLING AN AUXILIARY BATTERY

The optional auxiliary battery compartment allows the run-time of the TH50C V2 to be expanded to 10+ hours. 18500, or 18650 with adapter, rechargeable li-ion batteries (optional/not included) are compatible with the TH50C V2.

Ensure the 18500/18650 auxiliary battery is fully charged before using with the TH50C V2 for the first time.

To install an auxiliary battery:

1. Remove the auxiliary battery cover (11) by turning it counterclockwise.
2. Insert a 18500 battery (or 18650 plus adapter) (12) into the auxiliary battery compartment (13) following the polarity markings inside the compartment. The positive [+] battery terminal faces in and the negative [-] terminal faces out.
3. Replace the battery cover.

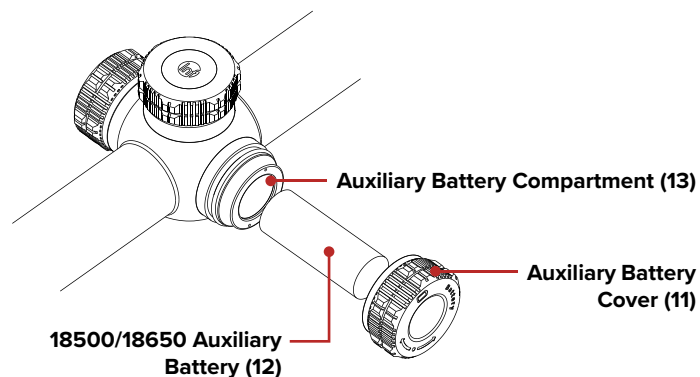

NOTE: If using a 18650 battery, replace the standard auxiliary battery cover (11) with the IRAY-AC37 18650 Battery Extender (optional/not included).

10. BATTERY STATUS INDICATORS

The status indicator for the built-in battery pack appears in the bottom-right corner of the screen.

If an optional auxiliary battery is installed in the TH50C V2, a status indicator for the auxiliary battery appears in the bottom-left corner.

The status indicator for the active battery (the battery currently being used to power the TH50C V2) is displayed in color, while the status indicator for the inactive battery is displayed in gray.

Each battery status indicator has 5 bars which indicate the current battery charge level. The color of the indicator bars for the active battery also indicates the current charge. See the table below.

When charging the built-in battery via the USB-C port, a charging ⚡ icon appears above its battery status indicator.

Charge the built-in battery pack promptly when it reaches one bar (5–20%) to avoid over-discharge and potential damage to the battery.

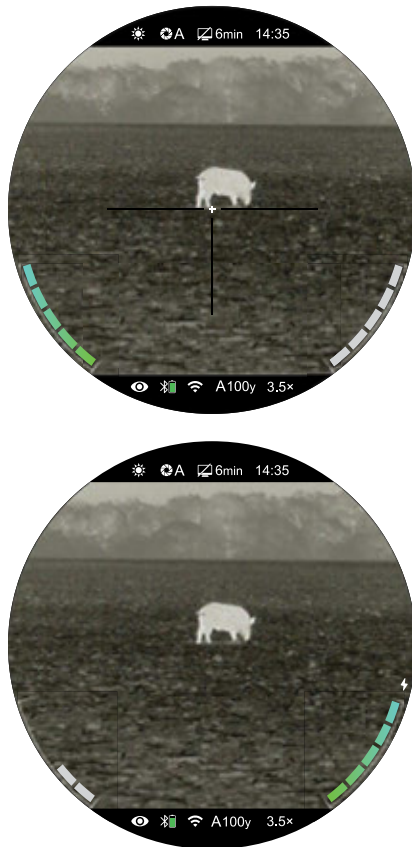

11. SWITCHING THE BATTERY POWER SUPPLY

The BOLT TH50C V2 has a dual power supply system with a built-in li-ion battery pack and an auxiliary battery option. 18500, or 18650 with adapter, rechargeable li-ion batteries (optional/not included) are compatible with the TH50C V2.

Using with the Optional Auxiliary Battery

- When both the built-in battery pack and the auxiliary battery are fully charged, the TH50C V2 will automatically select the auxiliary battery as its primary power source.
- If the power of the auxiliary battery is low, or the auxiliary battery is removed, the TH50C V2 will automatically switch to the built-in battery pack as its primary power supply. Operation will not be interrupted during this time.
- When the TH50C V2 is in use, you may insert (or replace) an auxiliary battery without powering off. Power will automatically switch to the built-in battery during replacement of the auxiliary battery.

Using with an External Power Source

When the data cable is used to connect the TH50C V2, via the USB-C port, to a computer or external power source (such as a standard wall outlet or an external power supply), the rifle scope will switch to the external power source and begin charging the built-in battery pack. See **External Power Supply** on the next page for more information.

When charging the built-in battery via the USB-C port, a charging ⚡ icon appears above the battery status indicator for the built-in battery. See **Battery Status Indicators** on page 12.

NOTE: Only the built-in battery pack will be charged while connected via the USB-C port.

12. BATTERY SAFETY PRECAUTIONS

WARNING: Only use the USB charging/data cable provided in the kit to charge the built-in battery pack. Only charge the TH50C V2 with a standard USB adapter (5V–2A), as included in the TH50C V2 kit. Using any other types of adapters may lead to irreversible damage to the battery, adapter, or rifle scope. This damage is not covered under warranty.

WARNINGS:

- Do not use a power adapter or USB cable that has been modified or damaged.

BARS	COLORS	BATTERY STATUS
5 Bars	Green to Blue	81% – 100%
4 Bars	Green to Blue	61% – 80%
3 Bars	Green to Blue	41% – 60%
2 Bars	Yellow to Orange	21% – 40%
1 Bar	Orange to Red	5% – 20%; charge the battery promptly
Charging Icon ⚡		The built-in battery pack is charging (external power supply or computer is connected via the data cable)

- Do not expose the battery pack to high temperatures or flames and do not immerse in water.
- Do not leave the TH50C V2 unattended while charging the battery pack.
- Do not leave the battery pack charging for long periods after full charge is reached. Charging time should not exceed 24 hours.
- Keep the battery pack and rifle scope out of the reach of children and pets.
- The built-in battery pack is equipped with short-circuit protection. However, any situation that may cause short-circuiting should be avoided.
- Do not connect the battery pack to any external device with an electrical current that exceeds permitted levels.
- Do not disassemble, modify, hit, or drop the battery pack.
- Do not connect an external device with a current supply that exceeds 3.0 USB port.
- Only use compatible 18650, or 18500 and adapter, rechargeable batteries (not included/optional) in the auxiliary battery compartment.

To maintain optimal battery capacity and service life:

- Avoid storing a fully charged or discharged battery for long periods. Partially charging the battery is necessary if the battery will be stored for an extended period.
- If your TH50C V2 has been stored for an extended period, it should be charged before initial use.
- Do not charge an extremely cold battery without bringing it into a warm environment. Let the battery warm up for 45 minutes before charging.
- Charge the battery at a temperature range from 30°F to 100°F; otherwise, the service life of the battery may be reduced.
- The recommended operation temperature range is -4°F to 122°F. Avoid using the battery pack above the maximum or below the minimum recommended temperature range as this may decrease the battery pack capacity or service life.

13. EXTERNAL POWER SUPPLY

The BOLT TH50C V2 supports the use of an external power supply, such as a 5V power bank for a mobile phone. The external power supply may be used with or without the optional auxiliary battery installed.

To connect the TH50C V2 to an external power supply:

1. Remove the USB-C port cover **(8)** by turning it counterclockwise.
2. Connect the smaller USB-C end of the data cable to the USB-C port **(9)**.

3. Connect the larger USB end of the data cable to the external power supply. The TH50C V2 will automatically switch to using the external power supply for power and it will begin charging the internal battery pack.
 - a. A charging ⚡ icon appears above the battery status indicator for the built-in battery pack in the bottom-right corner of the screen, indicating that the battery is charging.
 - b. The number of bars and color of the battery indicator will change to reflect the current charge level. See **Battery Status Indicators** on page 12.
4. When the external power supply is turned off, the TH50C V2 will switch to the auxiliary battery without turning off.
5. If no auxiliary battery is installed or the auxiliary battery level is low, the TH50C V2 will switch to the built-in battery pack, instead of shutting down.

NOTE: Do not connect the TH50C V2 to an external device with a power supply that exceeds the 3.0 USB cable.

14. MOUNTING THE BOLT TH50C V2

To ensure accurate results, please first properly mount the BOLT TH50C V2 on your rifle.

The TH50C V2 rifle scope is mounted using traditional 30mm ring mounts, such as the ring mounts included in the package. Follow the ring manufacturer's installation instructions and torque the ring caps to 20 in/lbs. A torque driver is required to control the torque.

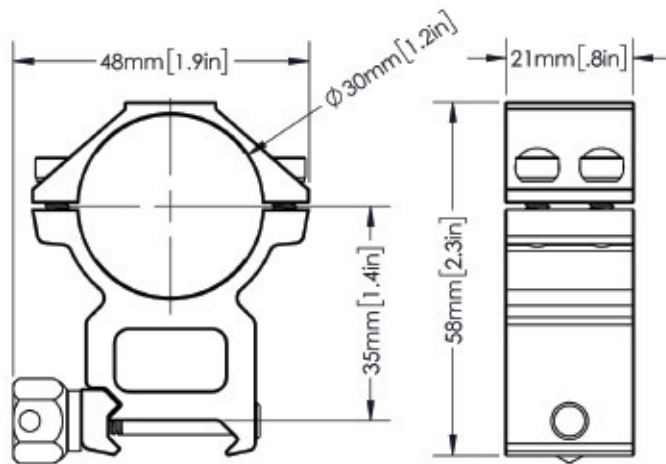

MOUNTING NOTES:

- When mounting the TH50C V2 on a rifle, adjust its position so that proper eye relief (50 mm) is achieved. Failure to comply with this recommendation may result in injury to the shooter by the eyepiece when shooting.

- It is recommended to install the TH50C V2 as low as possible for a proper cheek weld; however, make sure to avoid contact with the barrel or receiver.
- After mounting, but before hunting with the TH50C V2, zero the rifle scope. See **Zeroing the BOLT TH50C V2** on page 22 for instructions.

15. OPERATING INSTRUCTIONS

WARNING!

Don't point the objective lens towards any intense energy sources, such as laser radiation or the sun. This may render the electronic components inoperative. The warranty does not cover damage caused by improper operation.

Control Features

The BOLT TH50C V2 is operated via four control buttons and a large metal tactile control turret. The large, easy-to-find control turret provides audible and tactile feedback when twisted or pressed.

The control buttons can be used to perform shortcut operations from the home screen, as well as in the menu and full-screen interfaces. See **Description of Control Buttons and Shortcuts** on page 6 for shortcut button details.



Powering On / Starting

1. Open the objective lens cap (15).
2. Long press the **Power**  **Button** for 2 seconds to power on the TH50C V2.

To determine the current charge of the built-in battery pack, check the battery level indicator in the bottom-right corner of the screen. See **Battery Status Indicators** on page 12.



Powering Off / Stopping

To power off the TH50C V2:

1. Press and hold the **Power**  **Button**. The standby screen will open, showing a 3-second countdown.
2. Continue holding the **Power**  **Button** until the 3-second countdown completes.



3. “Data saving...” appears on the screen and the TH50C V2 will shut down automatically after the data finishes saving.

NOTE: Releasing the **Power**  **Button** at any time before the countdown reaches zero will stop the shutdown process and the rifle scope will enter standby mode. Short press the **Power**  **Button** to exit standby.

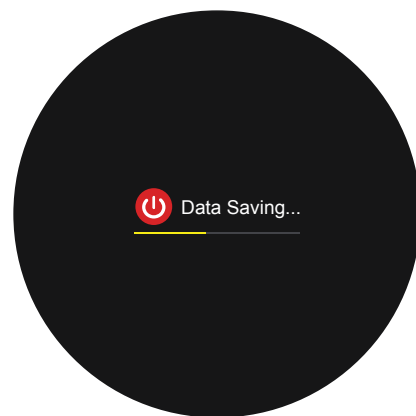

WARNING: If using an external power supply, do not disconnect the power supply when saving data, otherwise the data may not be saved.

STANDBY MODE

Standby mode may be activated to conserve the battery life of the rifle scope. When in standby mode, short press the **Power**  **Button** to exit standby and return to the home screen.

Automatically Enter Standby Mode

In the main menu, the TH50C V2 may be set to automatically enter standby mode after a specified length of inactivity (2, 4, or 6 minutes). See **Main Menu > Standby** on page 37 for detailed instructions.



1. In the main menu, select the desired standby time, 2, 4, or 6 minutes.
2. The standby icon  and status (2min, 4min, 6min, or off) appear in the top status bar.
3. Once set, the TH50C V2 will automatically enter standby mode, after the set length of inactivity, to conserve battery life.

NOTES:

- When **2min**, **4min**, or **6min** is selected:
 - The TH50C V2 will enter standby mode automatically when it is tilted up or down at an angle of more than 70° or left or right at an angle of more than 30°.
 - The TH50C V2 will not enter standby mode while it is in a level position.
- When **off** is selected, standby mode is turned off and the rifle scope will operate until the batteries run out.

Manually Enter Standby Mode

The user may enter standby mode manually at any time.

1. From the home screen, long press the **Power**  **Button** to bring up the shutdown/standby screen.
2. Release the **Power**  **Button** before the 3-second countdown finishes to enter standby.

Adjusting the Focus

ADJUSTING THE DIOPTER/EYEPIECE

1. Rotate the eyepiece diopter adjustment ring **(2)** at the rear of the rifle scope right or left until the onscreen user interface is clear.
2. Look closely to ensure all icons, the status bars at the top and bottom of the screen, and the reticle appear sharp and in focus. No additional diopter adjustments are required unless the user wishes to make changes.

NOTES:

- After this initial adjustment, there is no need to rotate the eyepiece adjustment ring **(2)** for long distances or any other conditions.
- If necessary during standard use, you may rotate the objective lens focus ring **(14)** to adjust fine focus on the target object being observed. See **Focusing the Objective Lens** below.

FOCUSING THE OBJECTIVE LENS



To adjust the focus on the target object:

1. Rotate the objective lens focus ring **(14)** left or right to focus on the target object being observed.

NOTE: Re-adjusting the focus will be needed if the distance to your target changes.

Activating / Deactivating the Reticle







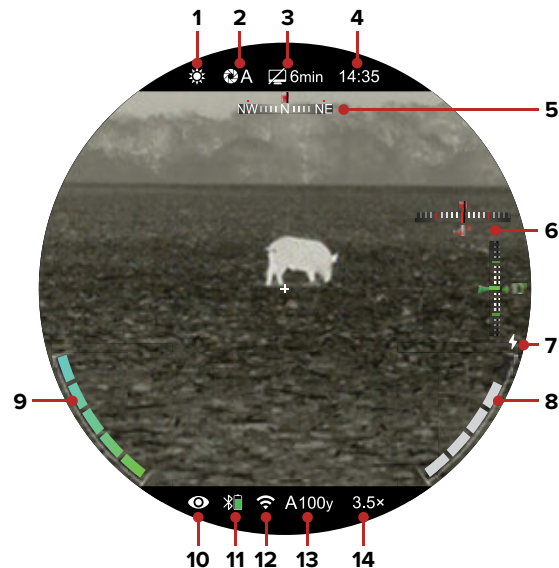

The reticle may be inactive when the TH50C V2 is powered on for the first time. To activate the reticle, or to deactivate it at a later time:









1. From the home screen, press and hold the **Photo**  and **Brightness**  **Buttons** at the same time for at least 15 seconds.

Status Bar Overview

The status bars at the top and bottom of the screen show information on the operating status of the BOLT TH50C V2:





- 1 Color Palette:** Shows the set color palette, white hot , black hot , red hot , color , or highlight . White hot is the default.
- 2 Non-Uniformity Correction (NUC) Mode:** Shows the non-uniformity correction (NUC)  icon and selected mode, automatic **(A)**, manual **(M)**, and background **(B)**. Automatic is selected by default. A countdown timer will appear instead of the NUC mode when 5 seconds remain until an automatic NUC.
- 3 Standby:** Shows the standby  icon and status, 2min, 4min, 6min, or off. Standby is off by default.
- 4 Time:** Shows the current time in 24-hour format.
- 5 Digital Compass:** Displays when the compass is turned on. Compass is off by default.
- 6 Gravity Sensor:** The two gravity sensor indicators (tilt and pitch) display when the gravity sensor is turned on. The gravity sensor is off by default.
- 7 Battery Charging:** The battery charging  icon appears above the battery status indicator for the built-in battery pack when the TH50C V2 is connected to an external power source.
- 8 Built-in Battery Status Indicator:** Shows the battery status of the built-in battery pack. When the TH50C V2 is receiving power from the battery pack, the battery indicator is in color; when inactive, the battery indicator is gray.
- 9 Auxiliary Battery Status Indicator:** Shows the battery status of the rechargeable auxiliary battery. When the TH50C V2 is receiving power from the auxiliary battery, the battery indicator is in color; when inactive, the battery indicator is gray.



- 10 **Ultra-clear Mode:** Shows the Ultra-clear status, on  or off . Ultra-Clear mode is off by default.
- 11 **Bluetooth:** Shows the Bluetooth status:  (off),  (on and successfully connected to the ILR-1200-1 Bluetooth Laser Rangefinder; optional/not included), or  (on but not connected to the laser rangefinder). Bluetooth is off by default. The vertical battery icon  indicates the current battery level of the laser rangefinder module.
- 12 **Wi-Fi:** Shows the Wi-Fi status, on  or off . Wi-Fi is off by default.
- 13 **Zeroing Profile & Distance:** Shows the selected zero profile (A, B, or C) and the zero distance.
- 14 **Total Magnification:** Shows the real-time amplification, 3.5–14.0x.

Using the Quick Menu

In the quick menu, the reticle type and color, image sharpness, and zeroing distance may be quickly adjusted.



1. From the home screen, short press the **Control Turret** to enter the quick menu.
2. Rotate the **Control Turret** to switch between the quick menu items, described below. The selected menu item is back-highlighted in green.
 - a.  (**Reticle Type**): Short press the **Control Turret** to change reticle type, from 1–6. The reticle changes as the cursor moves through the reticle types. See **Reticle Types** on the next page.
 - b.  (**Reticle Color**): Short press the **Control Turret** to change the reticle color between white, black, red, and green. The reticle changes as the cursor moves through the color options.

- c.  (**Image Sharpness**): Short press the **Control Turret** to change the image sharpness level, from 1–5.
 - d.  (**Zeroing Distance**): Short press the **Control Turret** to change the selected zeroing distance within the currently selected zeroing profile. Only the zero distances in the selected profile will be available for selection. The selected zero profile and distance appear in the bottom status bar.
3. Long press the **Control Turret** to save changes and exit the quick menu.

NOTE: After 5 seconds of inactivity, the quick menu will close automatically, saving any changes made.

Reticle Types

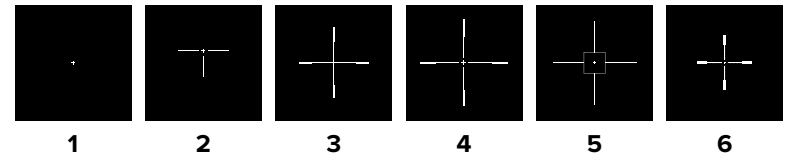

Navigating the Main Menu

From the home screen, long press the **Control Turret** to enter the main menu.





In all menu interfaces:

- Menu icons and text turn green to indicate the current selection and cursor position in the main menu.
- Submenu options are back-highlighted in green to indicate the current position in the submenu.
- Use the **Control Turret** to navigate the menu:
 - **Rotate** to move up and down through the menu to switch between the menu options.

- **Short press** to change the current parameters for the selected menu option, enter the submenu, or confirm submenu changes.
- **Long press** to save any changes and exit to the home screen.
- Short press the **Power**  **Button** to return to the previous menu without saving.
- After 15 seconds of inactivity, the menu will automatically close and the interface will return to the home screen. Changes are NOT saved automatically (except changes to toggle on / off menu items, such as Ultra-clear and Wi-Fi).
- Upon exiting from the main menu, the cursor location is stored for a single working session (until the TH50C V2 is turned off). After restarting the TH50C V2 and entering the menu, the cursor position will be at the first menu item.

16. ZEROING THE BOLT TH50C V2

BOLT TH50C V2 features a “freeze” zeroing method. To zero the TH50C V2:

1. Set a suitable target at the desired zero distance.
2. Confirm that the rifle is empty, safe, and pointed in a safe direction, with no ammunition near the weapon.
3. Adjust the image and device settings following the steps in the Quick Start Guide on page 8, if you have not done so already.
4. Select the zeroing profile, A, B, or C. See **Main Menu > Zeroing Profile** on page 33.
5. Based on the distance to the target you wish to zero, select a preset zero distance, OR customize one of the preset zero distances to match. The TH50C V2 supports custom zeroing distances of 1 to 999 meters or 1 to 999 yards. See **Reset Zeroing Distance Menu** on page 34.
6. Ensure a stable platform and natural shooting position is achieved behind the rifle.
7. Load ammunition, aim, and take one good shot at the target.
8. Make your rifle safe and observe the location of impact on the target.
9. If the point of impact does not match the point of aim (the center of the reticle), adjust the X/Y position of the reticle. See **Reset Zeroing Distance Menu > Reticle Zeroing** on page 34.
10. In the submenu for the selected zero distance, center the reticle on the aiming point and long press the **Photo**  and **Palette**  **Buttons** at the same time to freeze the image. The image freeze  icon appears at the bottom of the screen.

11. Select the axis (X or Y) along which to move the reticle by short pressing the **Control Turret** to toggle between X and Y.
12. Adjust the X/Y position of the reticle until the reticle matches the point of impact.
 - a. Rotate the **Control Turret** counterclockwise to move in the positive direction: X= Right and Y= Up.
 - b. Rotate the **Control Turret** clockwise to move in the negative direction: X= Left and Y= Down.
 - c. Upon moving the reticle, a white dot appears onscreen, representing the original position of the reticle.
13. Long press the **Control Turret** to save the reticle position.
14. Take a confirmation shot—the point of impact should now match the point of aim. If not, adjust the X/Y position of the reticle again.

For detailed Zeroing instructions, please see **Reset Zeroing Distance Menu > Reticle Zeroing** on page 34.

17. NON-UNIFORMITY CORRECTION

A non-uniformity correction (NUC) allows a thermal imager’s sensors to correct its pixels and eliminate any image defects caused by pixel drift. A NUC will be performed automatically each time the BOLT TH50C V2 is powered on.

The TH50C V2 has three NUC modes, automatic (**A**), manual (**M**), and background (**B**). The selected NUC mode (**A**, **M**, or **B**) appears in the top status bar. For instructions on setting the NUC mode in the main menu, see **Main Menu > Calibration** on page 37.

Automatic Mode

In automatic mode (**A**), the TH50C V2 will perform a NUC automatically according to the internal software algorithm. There is no need to close the objective lens cap (**15**) as the TH50C V2’s internal shutter covers the sensor.

A countdown timer will appear in the top status bar instead of the calibration mode when 5 seconds remain until an automatic NUC is performed. Short press the **Power**  **Button** before the countdown concludes to cancel the automatic NUC. The timer will appear only after the microbolometer temperature has stabilized—after approximately 10 minutes of continuous operation of the TH50C V2.

NOTE: A manual NUC (see below) may be performed at any time while in Automatic (**A**) mode.

Manual Mode

In manual mode (**M**), the user independently determines the need to perform a NUC based on the quality of the observed image. It is not necessary to close the objective lens cap (**15**) during a manual NUC, as the internal shutter covers the sensor.

To perform a manual NUC while in manual mode (or automatic mode):

1. From the home screen, short press the **Power**  **Button**.
2. A manual NUC is performed instantly.

Background Mode

In background mode (**B**), the user independently determines the need to perform a background NUC based on the quality of the observed image. A background NUC uses less power than an automatic or manual NUC because it does not use the imager shutter to cover the sensor; instead, the user must close the lens cap (**15**).

To perform a background NUC while in background mode:

1. Close the objective lens cap (**15**).
2. From the home screen, short press the **Power**  **Button**.
3. A prompt to close the lens cap appears onscreen. The background NUC starts after about 4 seconds.

NOTE: If the lens is not properly covered, a temporary “image burn” will remain in the image until the next non-uniformity correction. This “image burn” is temporary and is not a defect or sign of permanent damage.



18. PHOTOGRAPHY AND VIDEO RECORDING

The TH50C V2 is equipped with video recording and image capture. All videos and photos are automatically saved on the internal 32 GB memory storage.

NOTE: Photo and video files are named with the time and date; therefore, it is recommended to set the date and time before using the photo and video functions. See **Settings Menu > Date** and **Settings Menu > Time** on page 42. Alternatively, the date and time may be synchronized with one button in the InfiRay Outdoor App.

Photography

To take a photo:



1. From the home screen, short press the **Photo**  **Button**.
2. The image will freeze for 0.5 seconds and the camera  icon will appear briefly in the upper-left corner of the screen.



NOTE: An red warning icon  appears next to the camera icon in the upper-left corner of the screen when insufficient memory storage is available. Transfer video and image files to other storage media to free up space on the memory card.

Video Recording

To record video:

1. From the home screen, long press the **Photo**  **Button** to start a video recording.
2. When the video recording starts, the video recording timer, in HH:MM:SS (hour: minute: second) format, appears in the upper-right corner of the screen.
3. When recording, short press the **Photo**  **Button** to take a photo.
4. Long press the **Photo**  **Button** to stop and save the video recording.



Video and Photography Tips

- You may enter and navigate the menu as normal during video recording. Only the reticle appears in recorded photos and video; the user interface (status bar and menu) is not captured.
- Recorded photos are saved to the internal memory card in .jpg format, videos are saved in .mp4 format.
 - Photos are saved in IMG_HHMMSS_XXX.jpg format.
 - Videos are saved in VID_HHMMSS_XXX.mp4 format.
 - HHMMSS is hour/minute/second.
 - XXX is a 3-digit counter number.

- The counter used for the names of multimedia files cannot be reset.
- If a file is deleted from the list, its counter number is not taken by another file.

CAUTION:

- The maximum duration of a recorded video file is 10 minutes. After this time, video recording will begin a new file automatically.
- The number of recorded files is limited only by the capacity of the internal memory.
- Check the available space of the internal storage card regularly and transfer video footage and images to other storage media to free up the memory card space.

19. ACCESSING THE INTERNAL MEMORY

When the TH50C V2 is turned on and connected to a computer via the included data cable, it is recognized by the computer as a flash memory (USB) drive. This allows the user to access the saved multimedia files and copy or delete any desired files.

To access the internal memory:

1. Turn on the TH50C V2 and remove the USB port cover (8).
2. Connect the smaller USB-C end of the data cable to the USB-C port (9).
3. Connect the larger USB end of the data cable to your computer.
4. Double-click **My Computer** on the desktop of your computer.
5. Double-click to open the USB drive named **Infiray**.
6. Double-click to open the folder named **Internal Storage** to access the built-in memory.
 - a. The device shows the available space (in GB) remaining of the total memory storage.
 - b. Recorded photos and videos are separated by date into folders.
 - c. Folders are named by date, in YYYYMMDD (year/month/day) format.
7. Select the desired files or folders to copy or delete.

20. USING THE INFIRAY OUTDOOR APP

The BOLT TH50C V2 can be operated using the InfiRay Outdoor App when the rifle scope is connected to a smartphone or tablet via Wi-Fi.



1. Download and install the App to your smartphone or tablet:
 - a. Scan one of the QR codes above to download the InfiRay Outdoor App from the App Store or Google Play; **OR**
 - b. Download the App for free via any app store.
2. Connect the TH50C V2 to Wi-Fi:
 - a. In the main menu, turn on Wi-Fi. See **Main Menu > Wi-Fi** on page 31 for detailed instructions.
 - b. Open the App and press the **ViewFinder**  icon on the home screen.
 - c. Click the **Connect Device WiFi** button.
 - d. On the mobile device, go to **Settings > Wi-Fi**.
 - e. Select the TH50C V2 from the list of Wi-Fi networks. It will appear in the list as “TH50C_XXXXXX”, where XXXXXX is the six-digit device serial number.
 - f. Enter the Wi-Fi password and tap the **Join** button. The default password is 12345678.
3. Operate the TH50C V2 via the App:
 - a. Take real-time photos and videos, with or without audio.
 - b. View, share, download, and delete photos and videos taken via the App, which are saved to the mobile device.
 - c. Change the Wi-Fi password and SSID.
 - d. Synchronize the date and time from the mobile device to the TH50C V2.
 - e. Update the TH50C V2 firmware.

NOTE: When a factory reset is performed, the Wi-Fi password and SSID are reset to the defaults, 12345678 and TH50_XXXXXX. See **Settings Menu > Factory Reset** on page 45.

21. DIGITAL ZOOM

The BOLT TH50C V2 uses stepped zoom and can quickly increase the base magnification from 3.5× to 14.0× by enlarging the image from 1 to 4 times digitally.

To use digital zoom:

1. From the home screen, rotate the control turret to zoom in and out on the observed object.
 - a. Rotate clockwise to zoom in and counterclockwise to zoom out.
 - b. Each rotation click zooms in / out in increments of 0.35×.
2. The real-time amplification number, 3.5–14.0×, appears in the bottom status bar.



22. PICTURE IN PICTURE (PIP)

The PIP (Picture in Picture) function opens a small floating window with a magnified image-view at the top of the screen. PIP allows for improved aiming while still being able to see the wide field of view in the main body of the screen.

To activate PIP mode:

1. From the home screen, long press the **Palette Button**.
2. A 2× zoomed image, centered on the reticle, will appear at the top of the screen. Please note that the PIP image is 2× that of the total zoom shown in the bottom status bar.
3. To exit PIP mode, long press the **Palette Button**.

NOTE: When the image in the main body of the screen is magnified via digital zoom, the PIP image will enlarge accordingly.

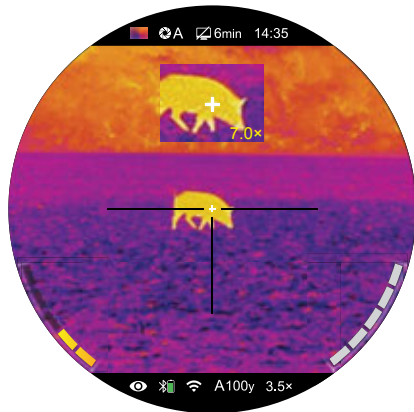

23. BLUETOOTH LASER RANGEFINDER

The BOLT TH50C V2 is compatible with the IRAY-AC96 ILR-1200-1 Bluetooth Laser Rangefinder Module (optional/not included). Please consult the documentation included with the ILR-1200-1 for information on its operation.

When the optional ILR-1200-1 is connected to the TH50C V2 via Bluetooth, the stadiametric rangefinder is unavailable.

24. STADIAMETRIC RANGEFINDER

The BOLT TH50C V2 is equipped with a stadiametric rangefinder, which allows the user to calculate the approximate distance to an object if its size is known.

To enter the stadiametric rangefinder:

1. From the home screen, long press the **Brightness Button**.

2. The stadiametric rangefinder interface has the following features:

- 1 Stadia Lines:** The two horizontal lines in the center of the screen can be adjusted to measure the size of the target object.
- 2 Icons and Distances:** Icons and distance values for three pre-configured objects will be displayed on the left side of the screen. The pre-configured objects are Deer: 5.6' tall, Hog: 3.0' tall, and Rabbit: 0.7' (7.9") tall.

Calculate the approximate distance of the observed object:

3. Rotate the **Control Turret** to expand or contract the space between the horizontal lines until they touch the top and bottom edges of the target object.
 - a. Rotate clockwise to expand the space between the lines.
 - b. Rotate counterclockwise to shrink the space between the lines.
 - c. As you adjust the space between the horizontal lines, the rangefinder distance values on the left side of the screen are automatically recalculated.
4. Long press the **Brightness Button** to exit the stadiametric rangefinder mode.

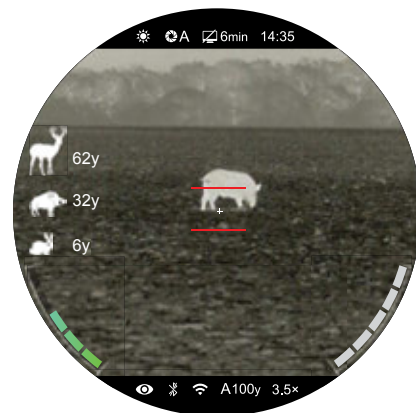

NOTES:

- The horizontal stadia lines are centered on the reticle, which remains onscreen.
- To change the units of measurement (meters or yards), see **Settings Menu > Units of Measure** on page 43.

25. ULTRA-CLEAR MODE

Ultra-clear mode improves the image quality in inclement weather conditions, such as rain, fog, high humidity, or high temperatures as these conditions all result in lower thermal contrast. Ultra-clear mode enhances the NETD value of the thermal sensor and improves the sensor's response rate to these challenging environmental conditions.

Ultra-clear mode provides:

- Improved image quality and clarity; images are crisper and sharper.
- Increased image detail.
- Improved recognition of observed targets.

See **Main Menu > Ultra-Clear** on the next page for instructions.

26. MAIN MENU OPTIONS AND DESCRIPTIONS

Menu and submenu options, from top to bottom are:



- **Main Menu:** Ultra-clear, Wi-Fi, Bluetooth, Gravity Sensor, Compass, Laser Calibration, Zeroing Profile, Reset Zeroing Distance, Calibration, Standby, Pixel Defect Correction, Compass Calibration, Settings.
 - **Reset Zeroing Distance Menu:** The three preset zero distance options.
 - **Zero Distance Submenu:** Reticle Zeroing, Custom Zero Distance.
 - **Settings Menu:** Date, Time, Language, Units of Measure, Status Bar, Image Hue, Factory Reset, Info.

Menu option details, descriptions, and navigation instructions are listed in order on the following pages.

Ultra-clear

Turn Ultra-clear mode on / off

Ultra-clear mode improves the image quality in inclement weather conditions, such as rain or fog.

1. Long press the **Control Turret** to enter the main menu.
2. Rotate the **Control Turret** to select the Ultra-clear  menu item. Ultra-clear is selected by default when the menu is accessed for the first time.
3. Short press the **Control Turret** to toggle Ultra-clear mode on / off. Ultra-clear mode is off by default.
4. The Ultra-clear status, on  or off , appears in the bottom status bar.
5. Long press the **Control Turret** to save and return to the home screen.



NOTE: When Ultra-clear mode is turned on and off, the TH50C V2 will automatically perform a shuttered non-uniformity correction.



Wi-Fi

Turn Wi-Fi on / off

Turn on Wi-Fi to manipulate the TH50C V2 via the InfiRay Outdoor App.

1. Long press the **Control Turret** to enter the main menu.
2. Rotate the **Control Turret** to move through the menu to select the Wi-Fi  menu item.
3. Short press the **Control Turret** to toggle Wi-Fi on / off. Wi-Fi is off by default.
4. The Wi-Fi status, on  or off , appears in the bottom status bar.
5. Long press the **Control Turret** to save and return to the home screen.



Bluetooth

The Bluetooth function of the BOLT TH50C V2 requires an IRAY-AC96 ILR-1200-1 Laser Rangefinder Module (optional/not included). Please consult the documentation included with your ILR-1200-1 for more information on its operation.

Gravity Sensor

Turn the gravity sensor on / off

1. Long press the **Control Turret** to enter the main menu.
2. Rotate the **Control Turret** to move through the menu to select the gravity sensor  menu item.
3. Short press the **Control Turret** to toggle the gravity sensor on / off. The gravity sensor is off by default.
4. When the gravity sensor is on, the tilt angle (red and gray indicator) and pitch angle (green and gray indicator) appear on the right side of the screen.
5. Long press the **Control Turret** to save and return to the home screen.



Compass

Turn the compass on / off

1. Long press the **Control Turret** to enter the main menu.
2. Rotate the **Control Turret** to move through the menu to select the compass  menu item.
3. Short press the **Control Turret** to toggle the compass on / off. The compass is off by default.
4. When the compass is on, it appears just below the top status bar.
5. Long press the **Control Turret** to save and return to the home screen.



Laser Calibration

The laser rangefinder function of the BOLT TH50C V2 requires an IRAY-AC96 ILR-1200-1 Laser Rangefinder Module (optional/not included). Please consult the documentation included with your ILR-1200-1 for more information on its operation.

Zeroing Profile

Select the zeroing profile

To zero the TH50C V2, you must first select a zeroing profile to adjust. Each of the three zeroing profiles, A, B, and C, have three zero distances.

1. Long press the **Control Turret** to enter the main menu.
2. Rotate the **Control Turret** to move through the menu to select the zeroing profile  menu item.
3. Short press the **Control Turret** to enter the zeroing profile submenu.
4. Rotate the **Control Turret** to move through the zeroing profile options, A, B, and C.
5. Short press the **Control Turret** to confirm the selection and return to the main menu.
6. The selected zeroing profile, A, B, or C, appears in the bottom status bar.



Reset Zeroing Distance

Select or customize zero distance

In the reset zeroing distance menu, you can select a preset zero distance, customize a preset zero distance, and adjust the reticle position for the selected zero distance. The BOLT TH50C V2 supports custom zeroing distances of 1 to 999 yards or 1 to 999 meters.





NOTE: Before selecting or customizing a zero distance, you must set a zeroing profile (A, B, or C). See **Main Menu > Zeroing Profile** on the previous page.

1. Long press the **Control Turret** to enter the main menu.
2. Rotate the **Control Turret** to move through the menu to select the reset zeroing distance  menu item.
3. Short press the **Control Turret** to enter the reset zeroing distance submenu. There are three zero distances available in the submenu.

ZEROING MENU > ZERO DISTANCE SUBMENU

Select or customize a preset zero distance

1. In the zeroing menu, rotate the **Control Turret** to select a zero distance.
2. Short press the **Control Turret** to enter the submenu for the selected zero distance.
3. In the submenu for the selected zero distance, you may:
 - a. Enter the reticle zeroing interface  to adjust the X/Y position of the reticle at the selected zero distance. See **Reticle Zeroing** below.
 - b. Customize the selected preset zero distance . See **Customize Zero Distance** on page 36.



ZEROING MENU > ZERO DISTANCE SUBMENU > RETICLE ZEROING

Adjust the reticle position of the selected zero distance.

In the reticle zeroing interface, the X/Y position of the reticle may be adjusted to match the point of impact. Refer back to **Zeroing the BOLT TH50C V2** on page 22, as needed.

1. In the submenu for the selected zero distance, the reticle zero  menu item is selected by default. Short press the **Control Turret** to select and enter the reticle zeroing interface.





2. The reticle zeroing interface has the following features:

- 1 **X:** Horizontal point of impact change (in cm or inches).
- 2 **Y:** Vertical point of impact change (in cm or inches).
- 3 **Freeze Icon:** Appears when the image is frozen.
- 4 **Reticle:** Shows the new reticle position.
- 5 **White Dot:** Indicates center of initial reticle position.



NOTE: The red “X” indicates the point of impact. It is shown in the figure for illustration purposes and is not an interface element.

3. Center the reticle on the aiming point and long press the **Photo**  and **Palette**  Buttons at the same time to freeze the image. The image freeze  icon will appear above the X/Y coordinates.
4. Select the axis (X or Y) along which to move the cursor:
 - a. Short press the **Control Turret** to switch between X and Y. The selected axis is back-highlighted in green. The X-Axis is selected by default.
5. Adjust the X/Y position of the reticle until the reticle matches the point of impact.
 - a. **X** (horizontal) is the windage and **Y** (vertical) is the elevation.
 - b. Upon moving the reticle, a white dot appears onscreen, representing the original position of the reticle.
6. Rotate the **Control Turret** counterclockwise to move in the positive direction: X= Right and Y= Up.
7. Rotate the **Control Turret** clockwise to move in the negative direction: X= Left and Y= Down.
8. Rotate one click to move the reticle in the corresponding direction by 1 pixel. One full rotation (20 clicks) is equivalent to 20 pixels.

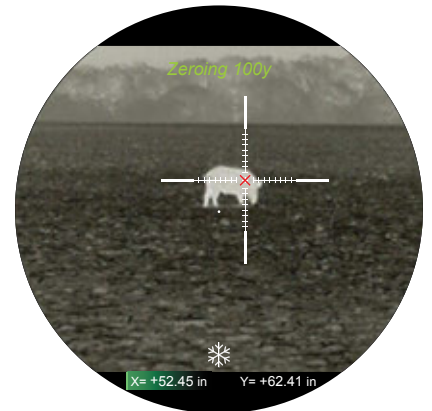

- f. When adjusting your zero at a distance of 50 yards, one click will change the impact point by 0.22" as shown in the X and Y coordinate displays. At 100 yards that same click moves 0.43". At 200 yards one click moves 0.87".
 - g. Changing your zero distance will change the distance of your X/Y adjustments automatically. If your selected zero distance has a correction of 1.30" at 100 yards, it will automatically change to 2.60" if you change the zero distance to 200 yards.
6. Short press the **Power**  **Button** to clear the reticle position and exit the reticle zeroing interface; **OR**
 7. Long press **Control Turret** to save the reticle position and return to the home screen. A 5-second countdown appears on the screen, followed by "Saved Successfully."
 8. Take a confirmation shot—the point of impact should now match the point of aim. If not, adjust the X/Y position of the reticle again.

ZEROING MENU > ZERO DISTANCE SUBMENU > CUSTOMIZE ZERO DISTANCE

Customize a preset zero distance

The BOLT TH50C V2 supports custom zero distances of 1 to 999 yards or 1 to 999 meters.

1. In the submenu for the selected zero distance, rotate the **Control Turret** to select the distance customization  menu item.
2. Short press the **Control Turret** to customize the zero distance. The selected distance is back-highlighted in green and white arrows appear above and below the first digit.
3. Rotate the **Control Turret** to increase or decrease the value of the first digit, from 0–9.
4. Short press the **Control Turret** to switch between the three digits. The two triangle icons will move to indicate the selected digit.
5. Long press the **Control Turret** to save the custom zero distance and return to the zero distance submenu.
6. The new zero distance appears in the bottom status bar.



Calibration

Select non-uniformity correction mode

The BOLT TH50C V2 has three non-uniformity correction (NUC) modes: Automatic (A), Manual (M) and Background (B).

1. Long press the **Control Turret** to enter the main menu.
2. Rotate the **Control Turret** to move through the menu to select the calibration  menu item.
3. Short press the **Control Turret** to enter the calibration submenu.
4. Rotate the **Control Turret** to move through the submenu options, Automatic (A), Manual (M), and Background (B). Automatic (A) is selected by default.
5. The selected NUC mode, A, M, or B, appears in the top status bar.
6. Long press the **Control Turret** to confirm the selection and return to the home screen.



Standby

Set automatic standby status and time

To conserve battery, the TH50C V2 may be set to automatically enter standby mode after a specified length of inactivity (2, 4, or 6 minutes).

1. Long press the **Control Turret** to enter the main menu.
2. Rotate the **Control Turret** to move through the menu to select the standby  menu item.



3. Short press the **Control Turret** to enter the standby submenu.

4. Rotate the **Control Turret** to move through the standby options, off, 2min, 4min, and 6min.



5. Short press the **Control Turret** to confirm the selection and return to the main menu.

6. The standby icon  and status (2min, 4min, 6min, or off) appear in the top status bar.

7. When 2, 4, or 6 minutes is selected, the TH50C V2 will automatically enter standby mode, after the set length of inactivity to conserve battery life.

8. When in standby mode, short press the **Power**  **Button** to exit and return to the home screen.

NOTES:

- When **2min**, **4min**, or **6min** is selected:
 - The TH50C V2 will enter standby mode automatically when it is tilted up or down at an angle of more than 70° or left or right at an angle of more than 30°.
 - The TH50C V2 will not enter standby mode while it is in a level position.
- When **off** is selected, standby mode is turned off and the rifle scope will operate until the batteries run out.
- Standby mode may be manually activated from the home screen at any time:
 - Long press the **Power**  **Button** to bring up the shutdown/standby screen. Release the **Power**  **Button** during the 3-second shutdown countdown to manually enter standby mode.
 - Short press the **Power**  **Button** to exit standby and return to the home screen.



Pixel Defect Correction

Select and correct defective pixels

Defective pixels are pixels that do not change correctly compared to the other image pixels—they are either brighter or darker than surrounding pixels. The BOLT TH50C V2 has a tool that corrects defective pixels on the sensor using its internal software.

1. Long press the **Control Turret** to enter the main menu.

2. Rotate the **Control Turret** to move through the menu to select the pixel defect correction  menu option.

3. Short press the **Control Turret** to enter the defective pixel correction interface.

4. The pixel correction interface has the following features:

- 1 X:** Select to move the cursor horizontally.
- 2 Y:** Select to move the cursor vertically.
- 3  00:** Shows the number of defective pixels in the “to be corrected” list.
- 4 Cursor:** Move the cursor to the position of the defective pixel. The cursor appears in the center of the screen in place of the reticle.
- 5 PIP Window:** Shows a close-up of the cursor location, and appears at the bottom of the screen.

5. Select the axis (X or Y) along which to move the cursor:

- a. Short press the **Control Turret** to switch between **X** and **Y**. The selected axis is back-highlighted in green. The X-Axis is selected by default.

6. Move the cursor along the selected axis to the location of the defective pixel:

- a. Rotate the **Control Turret** counterclockwise to move in the positive direction: X= Right and Y= Up.

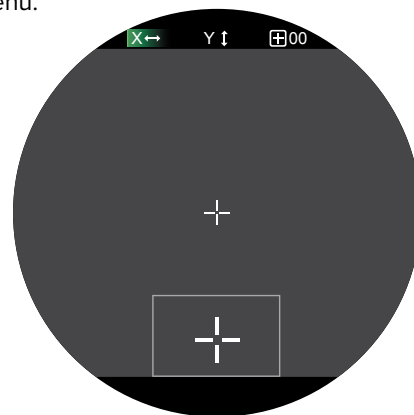
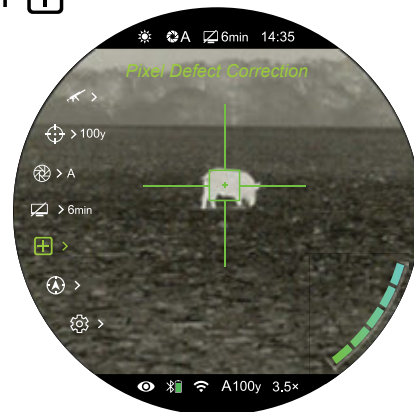



- b. Rotate the **Control Turret** clockwise to move in the negative direction: X= Left and Y= Down.
- c. Rotate one click to move the cursor in the corresponding direction by 1 pixel. One full rotation (20 clicks) is equivalent to 20 pixels.

7. Repeat steps 5–6 to move the cursor along the second axis.

8. With the cursor in position, short press the **Power**  **Button** to add the defective pixel to the “to be corrected” list.

- a. **Add** will briefly appear in the bottom-right corner of the PIP window.

- b.  00 will change to  01 to indicate that one pixel has been added to the correction list.

9. If the defective pixel has been added in error, short press the **Power**  **Button** a second time from the same X/Y coordinates (do not move the cursor) to remove the pixel from the “to be corrected” list. **Del** will briefly appear in the PIP window.

10. Repeat steps 5–9 to add additional defective pixels, as needed.

11. When all defective pixels have been added to the list, long press the **Control Turret** to confirm changes.

12. A popup window shows the message “Do you want to keep these settings?” and two options, Yes and No. Yes is selected by default.

13. Short press the **Control Turret** to select **Yes** to correct the saved list of defective pixels and exit to the home screen. A 5-second countdown appears on the screen, followed by a “Saved Successfully” ; **OR**

14. Rotate the **Control Turret** to move to **No** and short press the **Control Turret** to exit to the main menu without correcting any defective pixels.

NOTE: The PIP window will move to the top of the screen when the cursor moves into the bottom of the screen.

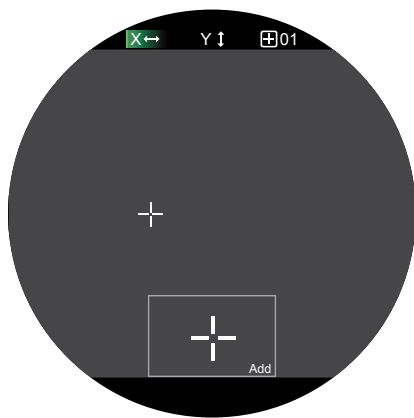

Compass Calibration

Calibrate the digital compass

1. Long press the **Control Turret** to enter the main menu.
2. Rotate the **Control Turret** to move through the menu to select the compass calibration  menu item.
3. Short press the **Control Turret** to begin compass calibration. A triaxial coordinate prompt will appear on the screen.
4. Follow the prompt to rotate the TH50C V2 at least 360 degrees along each axis, X, Y, and Z. Rotations must be completed within the 15-second calibration time.
5. After 15 seconds, the calibration is finished and the system will exit to the home screen.



Settings

Set general settings

1. Long press the **Control Turret** to enter the main menu.
2. Rotate the **Control Turret** to move through the menu to select the settings  menu item.
3. Short press the **Control Turret** to enter the settings submenu. There are eight submenu items: date, time, language, units of measure, status bar, image hue, factory reset, and info.
4. To make changes to any of the submenu items, use the **Control Turret**: rotate to navigate to the selected submenu item, short press to select it, rotate to change menu options, and long press to save any changes.



SETTINGS MENU > DATE

Set the date

1. In the settings submenu, the date  menu item is selected by default.
2. Short press the **Control Turret** to edit the date. White triangle icons will appear above and below the year value. The date is displayed in YYYY.MM.DD format.
3. Rotate the **Control Turret** to select the correct value for each digit (year, month, and day).
4. Short press the **Control Turret** to switch between digits. The two triangle icons move to indicate the selected digit.
5. Long press the **Control Turret** to save the date and return to the home screen.



SETTINGS MENU > TIME

Set the time

1. In the settings submenu, rotate the **Control Turret** to select the time  menu item.
2. Short press the **Control Turret** to edit the time. White triangle icons will appear above and below the hour value. The time is displayed in 24-hour format, HH:MM.
3. Rotate the **Control Turret** to select the correct value for each digit (hour and minute).
4. Short press the **Control Turret** to switch between digits. The two triangle icons move to indicate the selected digit.
5. Long press the **Control Turret** to save the time and return to the home screen.
6. The time appears on the top status bar.



SETTINGS MENU > LANGUAGE

Select the language

1. In the settings submenu, rotate the **Control Turret** to select the language  menu item.
2. Short press the **Control Turret** to enter the language submenu.
3. Rotate the **Control Turret** to move through the language options, English, German, and Russian. English is selected by default.
4. Short press the **Control Turret** to confirm the selection and return to the settings submenu.



SETTINGS MENU > UNITS OF MEASURE

Select the units of measure

1. In the settings submenu, rotate the **Control Turret** to select the units of measure  menu item.
2. Short press the **Control Turret** to enter the units of measure submenu.
3. Rotate the **Control Turret** to move through the options, meters and yards. Meters are selected by default.
4. The selected units of measure (**m** or **y**) will display, along with the selected zero profile and distance, in the bottom status bar.
5. Short press the **Control Turret** to confirm the selection and return to the settings submenu.



SETTINGS MENU > STATUS BAR

Turn status bar auto hiding on / off

This function enables all interface information, aside from the reticle, to be automatically hidden for unobstructed image-view.

When auto-hide is turned on, after 8 seconds of inactivity the status bar, digital compass, and all interface icons will be automatically hidden. Shortcut buttons and the menu are disabled until the entire interface is again displayed (press any button to un-hide the user interface).

NOTE: When auto-hide is on and the main menu is open, the menu will hide after 15 seconds of inactivity and the rest of the user interface will hide after an additional 8 seconds.

1. In the settings submenu, rotate the **Control Turret** to select the status bar  menu item.
2. Short press the **Control Turret** to enter the status bar submenu.
3. Rotate the **Control Turret** to move through the options, hide and show. Show is selected by default.
4. Short press the **Control Turret** to confirm the selection and return to the settings submenu.



SETTINGS MENU > IMAGE HUE

Set the image temperature

1. In the settings submenu, rotate the **Control Turret** to select the image hue  menu item.
2. Short press the **Control Turret** to enter the image hue submenu.
3. Rotate the **Control Turret** to move through the hue options, warm and cold. Cold is selected by default.
4. Short press the **Control Turret** to confirm the selection and return to the settings submenu.



SETTINGS MENU > FACTORY RESET

Reset to factory settings

1. In the settings submenu, rotate the **Control Turret** to select the factory reset  menu item.
2. Short press the **Control Turret** to enter the factory reset submenu. Two options, Yes and No, appear; Yes will restore factory settings and No will cancel the operation. Yes is selected by default.
3. Short press the **Control Turret** to select **Yes** to confirm the factory reset. Factory settings will be restored and the TH50C V2 will reboot automatically; **OR**
4. Rotate the **Control Turret** to move to **No** and short press the **Control Turret** to cancel the factory reset and return to the submenu.



NOTES:

- A factory reset cannot be undone.
- The settings listed below will be reset to the factory defaults:
 - Color Palette: White Hot
 - Display Brightness: 3
 - Image Sharpness: 3
 - Magnification: 3.5x
 - Reticle Type: 1
 - Reticle Color: Black
 - Ultra-clear mode: Off
 - Wi-Fi: Off
 - Bluetooth: Off
 - Gravity Sensor: Off
 - Digital Compass: Off
 - Calibration: Automatic
 - Standby: Off
 - Language: English
 - Units: Meters
 - Status Bar: Show
 - Image Hue: Cold
 - Wi-Fi SSID: TH50_XXXXXX
 - Wi-Fi Password: 12345678

SETTINGS MENU > INFO ⓘ

Show device information

1. In the settings submenu, rotate the **Control Turret** to move through the submenu and select the info ⓘ menu item.
2. Short press the **Control Turret** to enter the info submenu which displays the following information about the TH50C V2: GUI version, SYS Info, boot version, FPGA, PN and SN number, and hardware version.
3. Long press the **Control Turret** to return to the settings submenu.



- Cleaning the exterior of the lens should only be done with the included microfiber lens cloth or a similar product. Only clean the lens when it is visibly soiled. Frequent wiping or cleaning can degrade the anti-reflective lens coating.

27. BASIC INSPECTION

It is recommended to carry out a technical inspection before each use. Please check the following:

- The rifle scope appearance: there should be no cracks in the body or visible damage.
- The condition of the objective lens and eyepiece: there should be no cracks, greasy spots, dirt, or other deposits on the lens.
- The internal rechargeable battery pack should be fully charged.
- The control buttons and turret should be in working order.
- The mount should be tight and correctly installed on the rail.

28. BASIC MAINTENANCE

Always replace the objective lens cap (15) after use to avoid damaging or scratching the lens. Never touch the lens directly; oil from your skin can damage the lens coating and surface.

Basic maintenance should be carried out at least twice a year and includes the following steps:

- Wipe the surface of the external metal and plastic components with a clean, dry cotton cloth. Do not use chemical, corrosive, or abrasive cleaners. Canned air may also be used to clean the external components.
- Clean the electric contacts and battery slots on the rifle scope using a non-greasy organic solvent.
- Check the lens and eyepiece. If necessary, remove any dirt or sand from the optics; a non-contact cleaning method is preferred.

29. WARRANTY

At iRayUSA we're first and foremost hunters and users of our products and we understand that failure isn't an option. We also understand that having to wait extended periods for repair isn't something that a customer should have to put up with when something does go wrong. During your published warranty period, iRayUSA will repair or replace, at its discretion, any optic that becomes defective during normal use. Additionally, if we cannot fix your optic in less than one week, we will offer to replace it with a replacement product in like or better condition. If you would rather wait for your specific optic to be repaired, we can handle that too.

We know you've never seen this from a thermal manufacturer, neither have we, and that's why we started iRayUSA.

Our warranty follows the product and is not tied to the original owner. The warranty period is tied to the date of sale to the dealer. This warranty only covers normal use and does not cover cosmetic damage, normal wear, intentional damage, theft, loss, any act of God, or a condition caused by use other than intended. Any product that is modified, opened, or tampered with will void any warranty coverage. Any serial number damage or alteration on the product will be considered a modification. Be sure to register your BOLT TH50C V2 rifle scope at irayusa.com/register.

To return a product for repair:

1. Go to irayusa.com/warranty and click the **Request an RMA button** to request an RMA number. Returns will not be accepted without an RMA.
 2. The customer is responsible for shipping the product to iRayUSA, per the instructions included with the RMA. iRayUSA will return the product at no cost.
- The one-week timeline starts from the time of receipt of the product at iRayUSA.
 - iRayUSA is not liable for any damages or loss incurred when shipping to iRayUSA.
 - This warranty gives you specific legal rights, and you may also have other rights which vary from state to state.

Please give us a call at **800-769-7125**, visit irayusa.com/warranty, or email info@irayusa.com with any questions.

30. GENERAL TROUBLESHOOTING

The troubleshooting table below lists issues that may occur when operating the BOLT TH50C V2. Carry out the recommended troubleshooting steps in the order shown in the table. Please contact iRayUSA at 800-769-7125 or irayusa.com/support or an authorized vendor for assistance before attempting to perform any modifications or repairs beyond the scope of the troubleshooting procedures in this manual. Unauthorized repairs or modifications will void your warranty.

ISSUE	POSSIBLE CAUSES
The TH50C V2 will not turn on.	The built-in battery pack is very low or has completely discharged.
The TH50C V2 can not connect to a computer or external power supply.	External power supply has completely discharged.
	Computer is turned off.
	Data cable is damaged.
The TH50C V2 can not connect to the mobile device (smartphone or tablet).	Wi-Fi is not turned on.
	Wrong Wi-Fi password entered.
	Too many Wi-Fi signals near the TH50C V2.
Wi-Fi signal is lost or interrupted.	Smartphone or tablet is out of range of a strong Wi-Fi signal, or there are obstacles between the TH50C V2 and the mobile device.
The image is fuzzy, not clear, not balanced, with artifacts.	Non-uniformity correction is required.
The image is too dark.	Display brightness level is too low.
The GUI is clear, but the image is fuzzy.	The lens is not focused.
	There is dust on the interior or exterior optical surfaces of the lens.
	There is condensation on the interior or exterior optical surfaces of the lens.

TROUBLESHOOTING STEPS
Charge the built-in battery pack.
Check the external power supply and charge it if necessary.
Power on the computer.
Replace the USB-C to analog RCA/USB data cable.
Turn on the Wi-Fi in the main menu. See Main Menu > Wi-Fi on page 31.
On the mobile device, go to Settings > Wi-Fi and enter the correct password. The default password is 12345678. See Main Menu > Wi-Fi on page 31.
Move the TH50C V2 and mobile device to an area with no or fewer Wi-Fi signals.
<ul style="list-style-type: none"> • Try again when Wi-Fi signal is stable. • Relocate the TH50C V2 closer to the Wi-Fi signal.
Perform a non-uniformity correction. See Non-uniformity Correction on page 23.
From the home screen, short press the Brightness button to adjust the display brightness.
<ul style="list-style-type: none"> • Adjust the focus on the target by rotating the Objective Lens Focus Ring (14) • Adjust the image sharpness in the quick menu. See Using the Quick Menu on page 20.
<ul style="list-style-type: none"> • Wipe the outside optical surfaces with the included microfiber lens cloth.
<ul style="list-style-type: none"> • Wipe the outside optical surfaces with the included microfiber lens cloth. • Allow the TH50C V2 to dry by leaving it in a warm, dry environment for at least 4 hours.

ISSUE	POSSIBLE CAUSES
The aiming reticle shifts after firing rounds.	The TH50C V2 is not mounted securely or the mount is not secured on the TH50C V2.
The image of the object being observed is missing.	Looking through glass.
The TH50C V2 will not focus.	Image settings are not optimal for the current environmental conditions or the object being observed.
Image quality is too low or the detection range is reduced.	These issues may occur due to the weather conditions, such as snow, rain, humidity, and fog.
When the TH50C V2 is used in low-temperature conditions, the image quality of the surroundings is worse than in warm-temperature conditions.	Environmental conditions.

TROUBLESHOOTING STEPS
<ul style="list-style-type: none"> • Check that the TH50C V2 has been securely mounted. • Make sure you are using the same brand, type, and weight of the bullets as when the TH50C V2 and weapon were initially zeroed. • If the TH50C V2 was zeroed in different environmental conditions, a slight shift of the zero is possible.
Remove any glass windows from the field of view.
<ul style="list-style-type: none"> • Check the outer surfaces of the objective lenses and eyepiece and, where necessary, wipe away any dust, condensation, frost, etc. • In cold weather, you can use special anti-fogging coatings, such as those made for corrective glasses. • Adjust the focus on the target by rotating the Objective Lens Focus Ring (14). • Adjust the image sharpness in the quick menu. See Using the Quick Menu on page 20. • Adjust the image and device settings. See Quick Start Guide on page 8. • Turn on Ultra-clear mode. See Main Menu > Ultra-clear on page 31.
Turn on Ultra-clear mode. See Main Menu > Ultra-clear on page 31.
In warm-temperature conditions, objects being observed (surroundings and background) heat up differently because of thermal conductivity, thereby generating a high temperature contrast. Accordingly, the image quality produced by the rifle scope will be higher. In low-temperature conditions, the background will cool down to roughly the same temperature, and thus the temperature contrast is substantially reduced and image detail can go down as there is less contrast in the scene. This is a normal function of a thermal imager and is no indicator of actual detector performance.

31. NOTES

iRAYUSA

800-769-7125

682-499-0047

info@irayusa.com

PN: IRAY-PR151