

***NEWPORT***

***NK300***

Kayak Motor

---

User's Manual

Please read and retain this manual before using product

# Contents

<b>1 Product Overview</b> .....	<b>5</b>
1.1 Product Identification .....	5
1.2 Included in Your Box.....	6
<b>2 Technical Data</b> .....	<b>8</b>
<b>3 Safety Information</b> .....	<b>9</b>
3.1 Critical Safety Information.....	9
3.2 Before Use .....	11
3.3 During Use .....	11
3.4 After Use.....	12
<b>4 Installation</b> .....	<b>12</b>
4.1 Installation of the Bracket .....	12
4.1.1 Installation Using Existing Threaded Inserts.....	12
4.1.2 Installation With Drilling Holes Using a Template.....	13
4.1.3 Installation With an Adapting Plate.....	14
4.2 Setting up Your Steering.....	15
4.2.1 Setup With Control Cords at the Top.....	15
4.2.2 Adjusting Motor Depth of Water After Setup.....	16
4.2.3 Inserting the Motor Supporting Drum in the Bracket ...	17
4.2.4 Connecting the Cords .....	18
4.2.4.1 Cables to Control the Direction.....	18

4.2.4.2	Cable to Perform Reverse Lock .....	19
4.2.4.3	Cable to Lift the Motor.....	20
<b>4.3</b>	<b>Complete the Cord Setup.....</b>	<b>21</b>
<b>4.4</b>	<b>Using External Steering System .....</b>	<b>22</b>
<b>4.5</b>	<b>Adjust the Motor Trim Angle .....</b>	<b>23</b>
<b>4.6</b>	<b>Connect to the Speed Controller.....</b>	<b>23</b>
<b>4.7</b>	<b>Connect to the Battery .....</b>	<b>24</b>
<b>5</b>	<b>Controller Display.....</b>	<b>25</b>
<b>5.1</b>	<b>Overview of Multi-Function Display.....</b>	<b>25</b>
<b>5.2</b>	<b>Battery Display .....</b>	<b>26</b>
5.2.1	Estimated Percent of Remaining Battery Power .....	26
5.2.2	Switching Between Battery Types .....	27
<b>5.3</b>	<b>Error Status Display .....</b>	<b>28</b>
<b>5.4</b>	<b>Error Codes and Solutions.....</b>	<b>29</b>
<b>6</b>	<b>Operation.....</b>	<b>31</b>
<b>6.1</b>	<b>Start the Motor.....</b>	<b>31</b>
<b>6.2</b>	<b>Travel Forward/Reverse .....</b>	<b>32</b>
<b>6.3</b>	<b>Steering the Motor .....</b>	<b>33</b>
<b>6.4</b>	<b>Emergency Stop.....</b>	<b>34</b>
<b>6.5</b>	<b>Stopping the Motor.....</b>	<b>35</b>
<b>6.6</b>	<b>Tilting the Motor.....</b>	<b>35</b>
<b>6.7</b>	<b>Finishing the Trip.....</b>	<b>36</b>
<b>6.8</b>	<b>Stow and Park the Motor .....</b>	<b>36</b>
<b>6.9</b>	<b>Remove the Motor From the Kayak.....</b>	<b>37</b>

<b>7 Care and Service</b> .....	<b>38</b>
7.1 Care of Motor Components.....	<b>38</b>
7.2 Corrosion Protection.....	<b>38</b>
7.3 Care of Battery Usage.....	<b>38</b>
7.4 Replacing the Fin.....	<b>39</b>
7.5 Replacing the Propeller.....	<b>40</b>
7.6 Recalibrate the Throttle.....	<b>41</b>
<b>8 Customer Support</b> .....	<b>43</b>

# 1 Product Overview

The Newport kayak motor NK300 is designed with direct-drive and field-oriented-control technology to deliver the ultimate efficiency in a compact package. The propulsive power of the NK300 is roughly equivalent to a 3hp petrol outboard motor, but with silent and emission free power delivery.

The Newport kayak motor NK300 is compatible with conventional 36V deep cycle batteries, 36V LFP lithium battery, and 36V lithium cobalt oxide batteries. The battery type can be changed at the press of a button.

## 1.1 Product Identification

Check the figure below to find the serial number of your product. You will need this as a reference to access after-sale services.

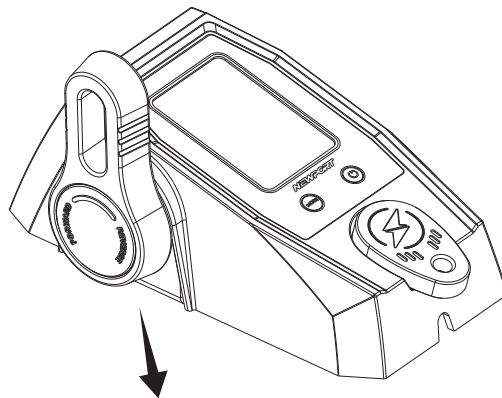

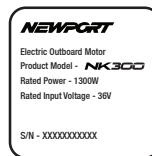

Serial No. is at the back of the controller

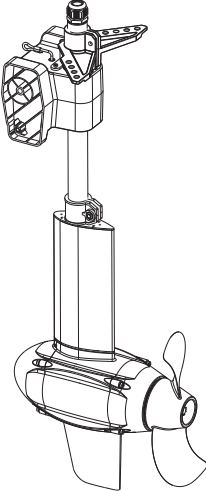
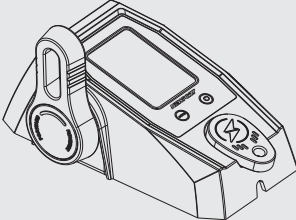
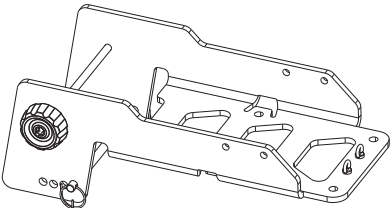

## 1.2 Included in Your Box

Here is what should be included in your Kayak Motor NK180. Please contact us directly if something is missing from this list of contents.

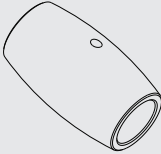
Items	Qty	Figure
Motor Unit	1 pc	
Controller	1 pc	
Motor Mount	1 pc	

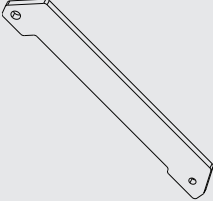
Items	Qty	Figure
Cable Handle	2 pcs	
Emergency Stop Key	2 pcs	
Swing Arm	1 pc	
Nylon Lift/Reverse Cable	2 pcs	
Battery Extention Cable	1 set	
Stainless Biner	4 pcs	
SS Steering Cable	2 pcs	
Installation Kit	1 set	
Signal Cable	1 pc	
User Manual	1 pc	

## 2 Technical Data

Specification	
Rated Input Power(static)	1300W
Comparable Petrol Outboard	3 HP
Battery Type	<ul style="list-style-type: none"> <li>• Deep cycle marine battery</li> <li>• LFP lithium battery</li> <li>• Lithium cobalt oxide battery</li> </ul>
Battery Input voltage	<ul style="list-style-type: none"> <li>• 36V-Deep cycle marine battery</li> <li>• 36V-LFP Lithium battery</li> <li>• 36V-Lithium cobalt oxide battery</li> </ul>
Max. Overall Efficiency	50%
Rated Rotation Speed	1500 rpm
Total Weight	22 lbs (10kg)
Shaft Length	21.7 in. (550 mm)
Steering	Cable steering
Control System	Digital control with accelerator lever
Stow Method	Cable lift with pulley
Trim Angle	Manual, 0°, 9°, 18°, 27°
Propeller Diameter	10.6 in. (270 mm)



## 3 Safety Information

### 3.1 Critical Safety Information

Please read all safety information before installing or operating your electric motor. Severe injury, damage, or even death can occur as a result of improper usage.

**⚠ DANGER!** There is a risk of death or severe injury from electric shock- use caution and do not touch any uninsulated wires or damaged parts.

- Do not use damaged batteries.
- If wiring is frayed or broken, do not touch it.
- If repair work is needed to the electrical components of your product, do not attempt to do it yourself.
- If there is any problem with the system, turn off the power immediately and avoid touching the metal components.

**⚠ DANGER!** There is a risk of explosion which could result in death, serious injury, or property damage due to the production of oxyhydrogen gas from the battery.

- If the battery becomes submerged in water deeper than one meter for a short period of time, do not attempt to recover the battery, and refer to the safety instructions provided by the battery manufacturer.
- If the battery has been submerged in shallow water, less than a meter, for more than 30 minutes, do not attempt to recover the battery, and refer to the safety instructions provided by the battery manufacturer.

**⚠ DANGER!** Electromagnetic radiation may cause death or severe injuries to people with **cardiac pacemakers**. Those with pacemakers should not get too close to the motor and should consult their physician about the proper distance for safety.

**⚠ WARNING!** There is inherent danger in using a boat- always prepare for the unexpected. A boat which is out of control can easily result in severe injuries or death by drowning.

- Always check weather predictions and water conditions before a trip on the water, and also familiarize yourself with a map of the area you'll be traversing.
- Depending on the size of your boat, make sure you bring any proper safety equipment. Paddle(s) and a communication device are a must for any size of boat, and if appropriate, also bring an anchor and extra drive.
- Always check your motor and system for any damage and ensure they are running properly before leaving the dock.

**⚠ WARNING!** Use caution around rotating components to avoid possible injury or even death.

- Do not wear loose clothing or jewelry near the motor shaft or propeller and tie up long hair.
- Never attempt maintenance or cleaning of the motor shaft or propeller without first shutting off the system.
- Power down the motor when there are people too near the propeller or motor shaft.
- Do not use the propeller out of the water.

**⚠ CAUTION!** Batteries can cause severe physical harm or even death in many different ways. Always read and follow all safety guidelines and instructions provided by your battery manufacturer.

- Never use third-party chargers for batteries, it could start a fire.
- If the battery catches fire during use, use water to cool the battery and prevent fire from spreading; however water will not extinguish a lithium fire- if possible, use sand to smother the fire.

**⚠ CAUTION!** Parts may be hot enough to cause burns. Do not touch the components or battery immediately after use; allow to cool sufficiently before handling the components.

**⚠ CAUTION!** Danger of crushing when tilting the motor- keep fingers, hands, and all body parts away from mechanical parts and the area of the motor when tilting the motor.

### 3.2 Before Use

- This motor should only be operated by an adult who has thorough understanding and command of the motor, including steering functions, emergency stop switch, and throttle.
- Always operate your boat and this motor in compliance with local safety regulations.
- Always carry a paddle on board at all times, especially when using an electric motor as your primary method of propulsion.
- All passengers should wear approved life jackets at all times.
- Check the status and condition of your motor and battery before each trip. We recommend starting every trip with a full battery charge.
- Do not operate the motor outside of the water.
- Do not modify the motor with non-original parts.

### 3.3 During Use

- Stop the motor immediately if someone is over board.
- Propellers are dangerous- use extra caution when operating the motor near areas where people may swim. Always be alert and aware of your surroundings when operating the motor.
- Do not exceed the recommended loading and power limitations of your boat as suggested by its manufacturer.

### 3.4 After Use

- Disconnect the motor from the battery after use.
- Flush the motor carefully with freshwater after each usage, especially after use in **saltwater**.
- Do not carry the kayak/boat by lifting with the bracket. This can cause damage to the boat and potentially to the bracket.

## 4 Installation

Installation Overview: The next several pages will give you detailed instruction on how to install your motor, one piece at a time. Please read all instructions carefully and refer to the diagrams.

### 4.1 Installation of the Bracket

First, remove the motor supporting drum from the bracket by opening the quick release lever and slightly loosening the bolt on the quick release axle.

#### 4.1.1 Installation Using Existing Threaded Inserts

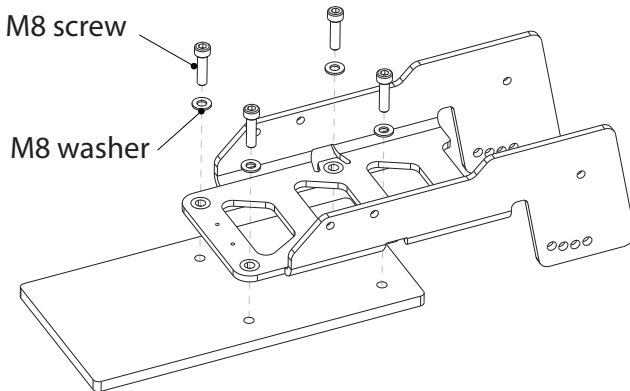

1. Place the bracket above the threaded inserts, align the holes on the bracket with threaded inserts

2. Place four M8 screws and four washers over the threaded inserts, as shown in the diagram above, and tighten the screws to mount the bracket. Make sure the screws are tightened and the bracket is flush and secure.

**NOTE:** We recommend applying torque of 140 in-lb (16Nm) to the screws.

#### 4.1.2 Installation With Drilling Holes Using a Template

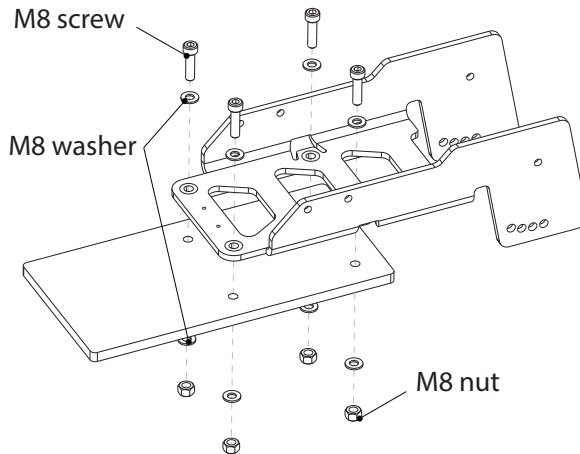

1. Find a proper location on your boat to drill holes. The typical suggested location is the end of the boat/kayak.
2. Drill holes 0.31in (8 mm) in diameter.
3. Place the bracket above the drilled holes, align the holes on the bracket with the drilled holes.
4. Place four M8 screws with washers over the holes, and four washers with four nuts beneath the holes, and tighten the screws to secure the bracket. Make sure the screws are tight and the bracket is flush on the deck and secure.

**NOTE:** We recommend to apply a torque of 140 in-lb (16Nm) to the screws.

Different kayaks may require different installation hardware. If your kayak requires installation hardware other than what is included in this kit, please find it at your local hardware store. Newport does not carry every possible hardware combination necessary to fit all brands and models of kayaks; however any additional mounting hardware needed for your individual craft should be standard, easy to find, and low-cost.

### 4.1.3 Installation With an Adapting Plate

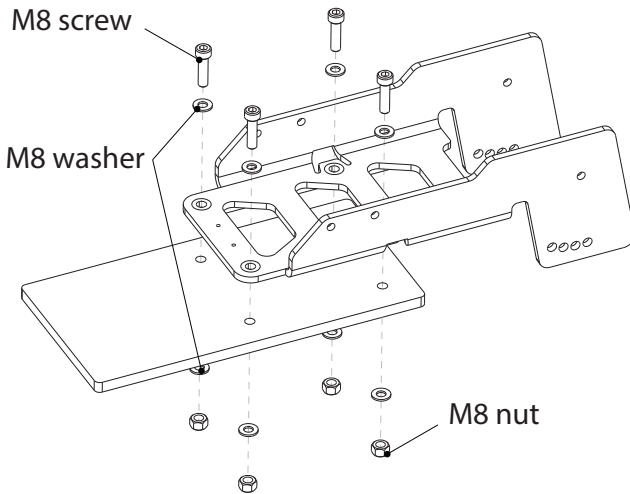

1. Place the bracket above the adapting plate and align the holes on the adapting plate with the holes on the bracket.
2. Place four M8 screws and four washers over the holes, four washers and four nuts beneath the holes, and tighten the screws to secure the bracket. Make sure the screws are tight and the bracket is secure.
3. Install the adapting plate in the intended location and make sure the adapting plate is correctly installed and secure.

**NOTE:** We recommend to apply a torque of 140 in-lb (16Nm) to the screws.

## 4.2 Setting up Your Steering

Kayaks feature many different cable routing systems, while some more basic models have no cable routing. To add cable routing to your particular boat, contact the boat manufacturer for recommendations.

Kayak cable routing can generally be broken down into two categories: cables routed above the deck of the kayak, and cables routed below the deck of the kayak.

Cables routed above deck will usually demand the steering triangle be mounted at the top of the shaft.

This mount is designed to work with high routing setups on kayaks equipped with integrated cable routing.

For kayaks with cable routing requiring you to use the high position, see section **Setup with Control Cords at the Top** on page 14.

In some cases, further tweaks may be required to refine the operation. See [www.newportvessels.com/kayak-motor-cable-routing/](http://www.newportvessels.com/kayak-motor-cable-routing/) for more information.

### 4.2.1 Setup With Control Cords at the Top

If you have a kayak setup with control cords running on the top of the kayak, follow the steps below to finish the motor control cords setup:

1. Assemble the swing arm and steering triangle as shown above, then insert the screw, washer, and nut as shown and attach loosely- don't tighten yet.
2. Place the screw, washer and nut on the clamping ring as figure shows, connect them loosely and don't tighten yet.
3. Slide the preassembled clamping ring onto the motor shaft.
4. Insert the motor shaft into the motor supporting drum with the clamping ring below the drum, as shown.
5. Slide the preassembled steering triangle onto the motor shaft above the drum, as shown.

6. Make sure the steering triangle is aligned with the direction of the motor. If the triangle is an arrow, it should point towards the front of the boat, while the propeller should face back.

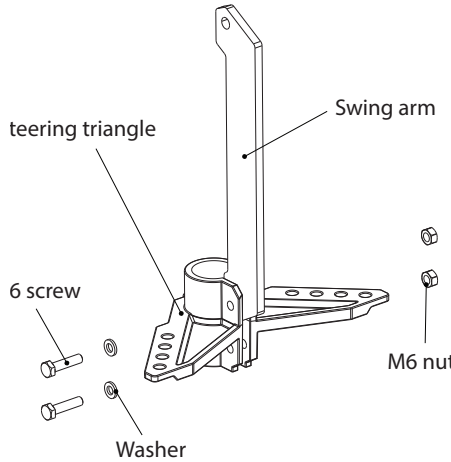

7. Tighten the screws on the clamping ring and the steering triangle.

In this setup, the steering triangle determines the depth of the motor. Make sure the propeller can be at least 2 inches (5 cm) below the water surface.

#### 4.2.2 Adjusting Motor Depth of Water After Setup

1. Hold the motor firmly and loosen the screw on either the clamping ring or the steering triangle, whichever is topmost on the shaft in your set up.
2. Adjust shaft position to find the optimum motor depth in water.
3. Tighten the screws on the clamping ring or the steering triangle (whichever you have on the top of the shaft).

**NOTE:** Be aware, the screw on the steering triangle or the clamping ring must be tightened well, otherwise the motor may fall into the water!



### 4.2.3 Inserting the Motor Supporting Drum in the Bracket

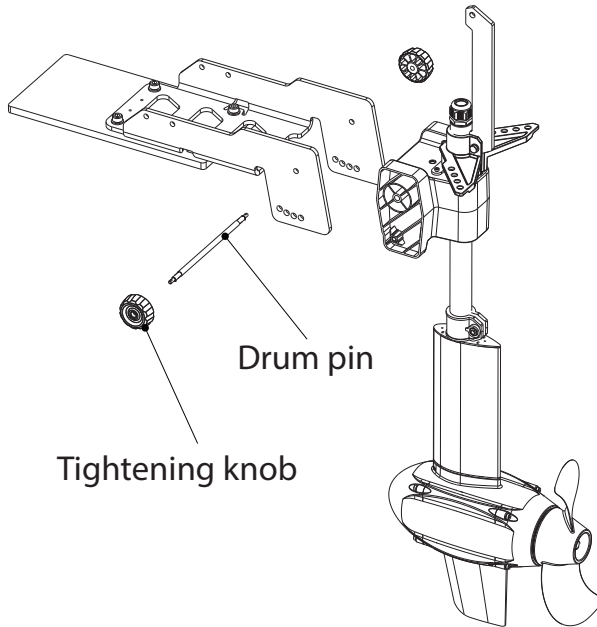

1. Place the motor assembly at the desired position, align the hole on the drum to the hole on the bracket.
2. Insert the drum shaft, make sure the shaft is centered.
3. Install the knobs on the both sides of the shaft. tighten the knobs.
4. Install the cotter pin on the both sides of drum shaft.

## 4.2.4 Connecting the Cords

### 4.2.4.1 Cables to Control the Direction

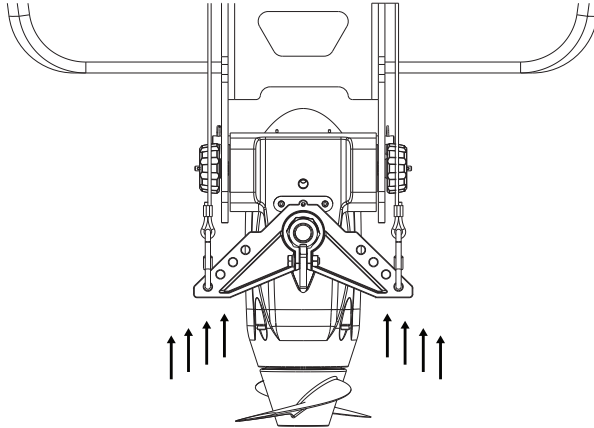

Directional control has 4 options to adjust steering fitment, feel and sensitivity

1. Secure the cable on one side of the stainless steel biner.
2. Attach the stainless steel biner to the steering triangle.
3. There are four options for steering sensitivity. Attaching the cable to the outer holes will mean direction changes happen more gradually, while attaching it to the inner holes will make direction changes more sudden. It is recommended that you start by hooking the stainless steel biner to the outermost holes.

#### 4.2.4.2 Cable to Perform Reverse Lock

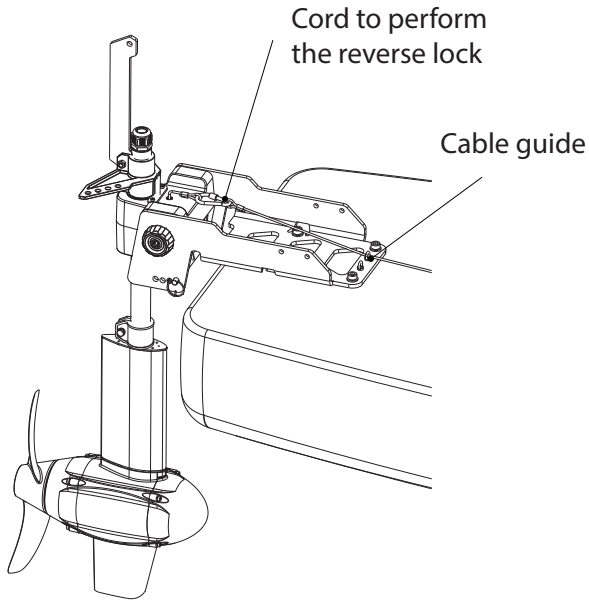

The reverse lock secures the motor when it is being used in reverse. It needs to be activated when motor is used in reverse to keep the motor from rotating up and out of water.

1. Tie the cable securely to one side of the biner.
2. Attach the S biner to the reverse lock cord as shown.
3. Thread the cord through the cable guide on the bracket as shown.
4. Install the handle at the other end of the cable.
5. Place the end of the cable where you can access it easily.
6. You may choose to create a dedicated guide for this cable near the handle location as well. See [www.newportvessels.com/kayak-steering-accessories/](http://www.newportvessels.com/kayak-steering-accessories/) for more products.

#### 4.2.4.3 Cable to Lift the Motor

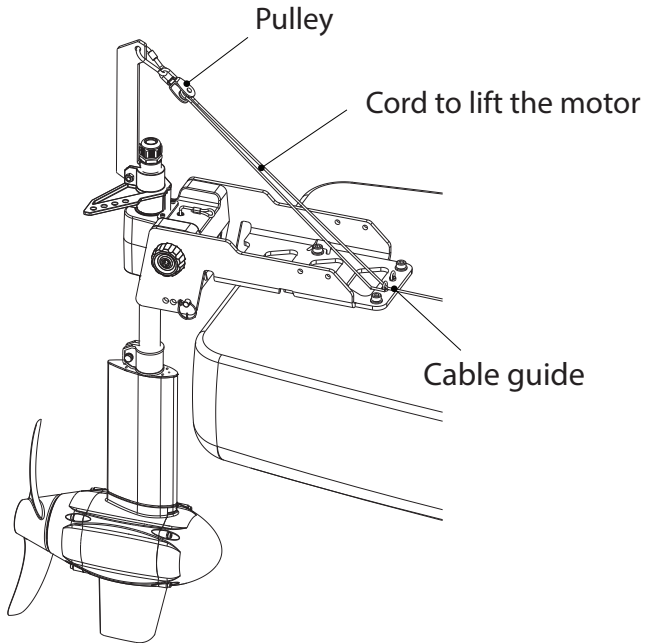

1. Tie the nylon cable securely to one of the eye nut.
2. Attach the stainless steel biner to the swing arm as shown.
3. Attach the pulley to the stainless steel biner on the swing arm.
4. Thread the cord through the pulley, and then the cable guide (eye nut) on the bracket- this is necessary to ensure proper function of raise/deploy function.
5. Install the handle on the other end of the cable.

### 4.3 Complete the Cord Setup

This is the overall setup of the motor after all control cables have been installed.

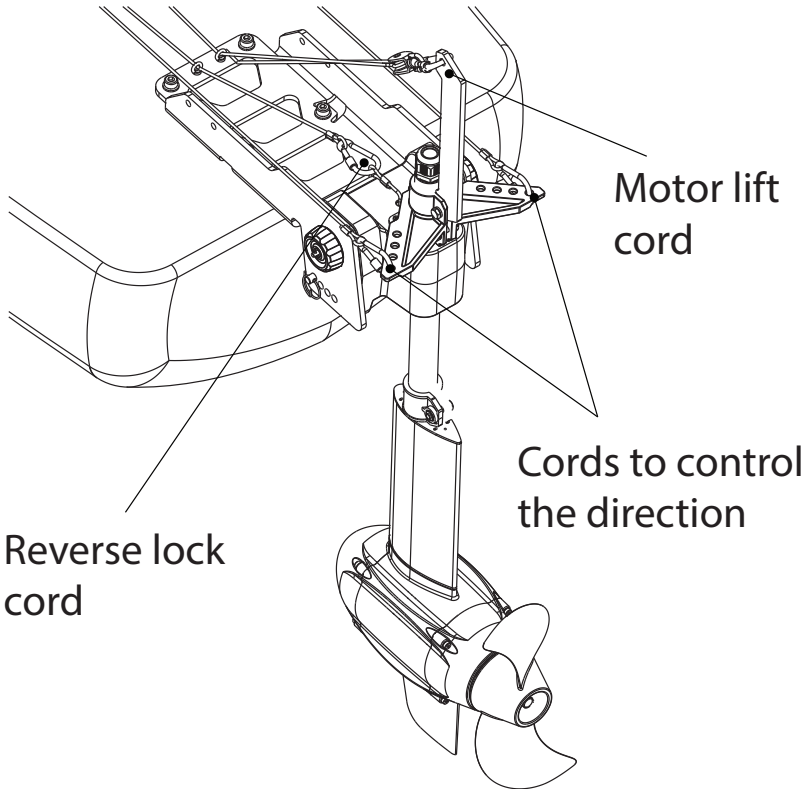

## 4.4 Using External Steering System

If you are planning on using the motor only for forward/reverse propulsion and are using other methods to steer such as a paddle, you can fix the motor direction with the following steps:

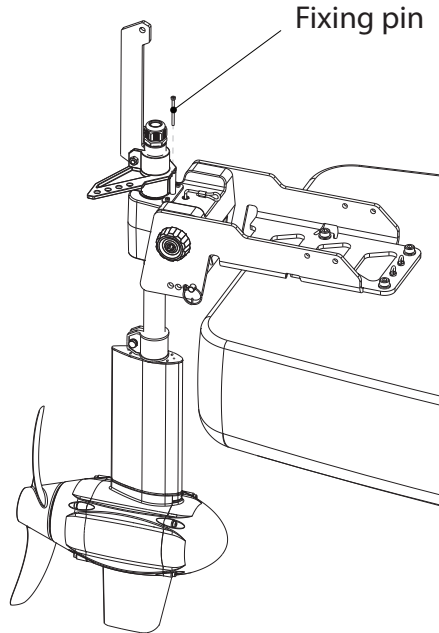

1. Remove the cords on the steering triangle.
2. Insert the fixing screw into the hole as shown.
3. Use the M3 Allen key to tighten the screw securely.
4. Now the direction of the motor is fixed.

## 4.5 Adjust the Motor Trim Angle

You can adjust the angle between water surface and the motor using the motor trim angle adjustment design. Follow the steps below if you would like to change the angle of the motor.

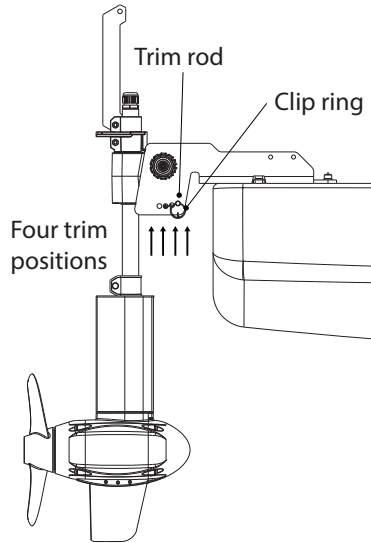

1. Tilt the motor up and hold it firmly.
2. Remove the R shaped cotter pin from the trim rod and pull the trim rod out from the current trim position of the bracket.
3. Adjust the motor to the desired angle.
4. Reinsert the trim rod through one of the four positions on the bracket, and insert the R shaped cotter pin to secure the trim rod.

**NOTE:** Be careful of finger pinching. You can use a flat head screw driver or needle nose pliers to help remove the cotter pin.

## 4.6 Connect to the Speed Controller

1. Find the signal cable coming from the motor shaft and connect it to the speed controller. Make sure the cable is tightly connected.

2. It is recommended to fit the cable into the cable tidy slot underneath of the speed controller.
3. You can choose to mount the speed controller at the most convenient location for operation. There are two M4 mounting holes with nuts pre-installed on the back of the speed controller which can be used to mount when needed.

## 4.7 Connect to the Battery

The motor is adaptable with 36V (three 12V batteries connected in series) deep cycle marine battery package, 36V LFP lithium battery (including three 12V LFP lithium batteries connected in series) and 36V lithium cobalt oxide battery package. Please follow the steps below to complete the battery connection.

1. Find the battery cables from the motor; there should be a red and a black cable.
2. Connect the red cable to the positive battery terminal and the black cable to the negative battery terminal.
3. Make sure the battery cables are connected to the correct terminal. The motor will not operate if battery cables are installed incorrectly.
4. Tighten the connection of the battery cables to the battery terminals. Make sure the connection is solid and secure.

**⚠ WARNING!** Be sure all switches are in the OFF position before connecting to battery or batteries. Electrical arcing near the battery could cause an explosion. The battery produces hydrogen and oxygen gases while charging. This potentially explosive mixture escapes through the fill vent cell caps and may form an explosive atmosphere around the battery for several hours after it has been charged. Electrical arcing or flames can ignite the gas and cause an explosion, which may shatter the battery and could cause blindness or other serious injury.



# 5 Controller Display

## 5.1 Overview of Multi-Function Display

The speed controller screen features motor and battery information for the operator to monitor.

There are two buttons on the speed controller to control the motor.

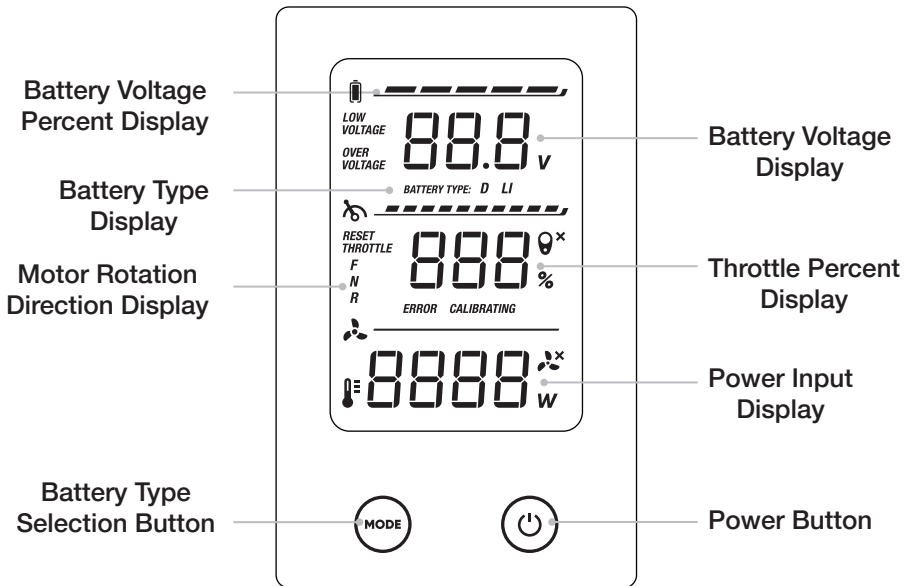

## 5.2 Battery Display

### 5.2.1 Estimated Percent of Remaining Battery Power

The battery bar has 6 different status levels to display the estimated remaining battery percentage.

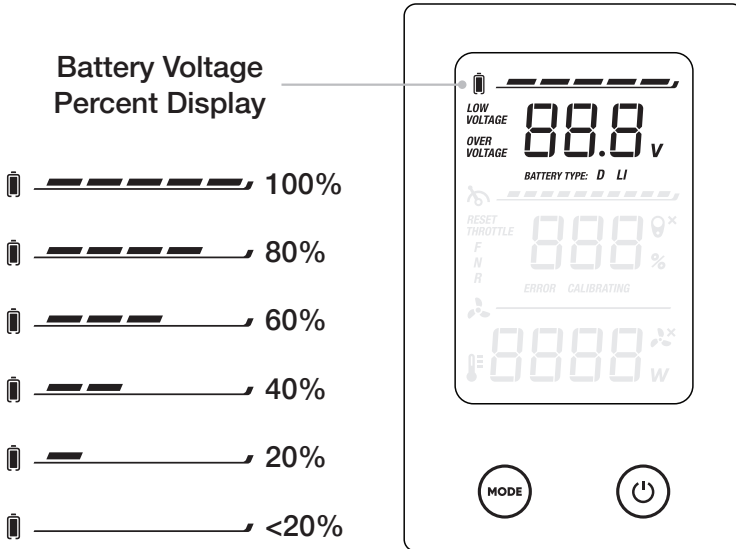

**CAUTION!** Do not overestimate the remaining battery range; this could result in severe harm or even death.

- Before you leave the dock, know the area you are traveling, how far you plan to go, and make sure to have an alternate plan for safely getting back if anything goes wrong with your motor or battery. Always bring a paddle.
- Monitor the battery level indicator during your trip and always leave a buffer for getting back to shore.

## 5.2.2 Switching Between Battery Types

This motor can run on a 36V deep cycle battery setup, a 36V LFP lithium battery setup, or a 36V lithium cobalt oxide battery.

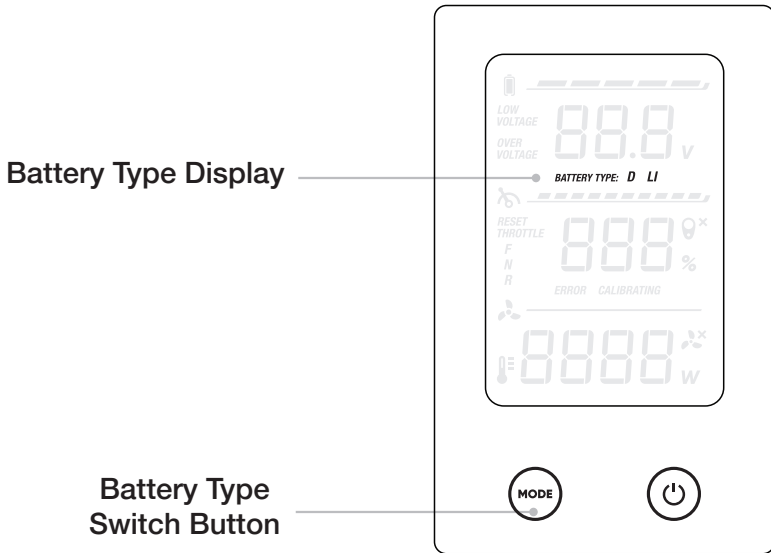

You will need to select which type of battery you are using with your motor for accurate results on the LCD screen. When the battery is connected to the motor, press the MODE button to toggle between the Li (LFP Lithium Battery or Lithium Cobalt Oxide Battery) or D (Deep Cycle Battery) battery options.

### 5.3 Error Status Display

The icons indicated on the LCD screen above show three possible error statuses of the motor. When a fault occurs, there will be a corresponding code on screen to help diagnose the problem. See section **5.4 Error Codes and Solutions**.

Motor Overvoltage: If the input voltage is too high, this icon will light

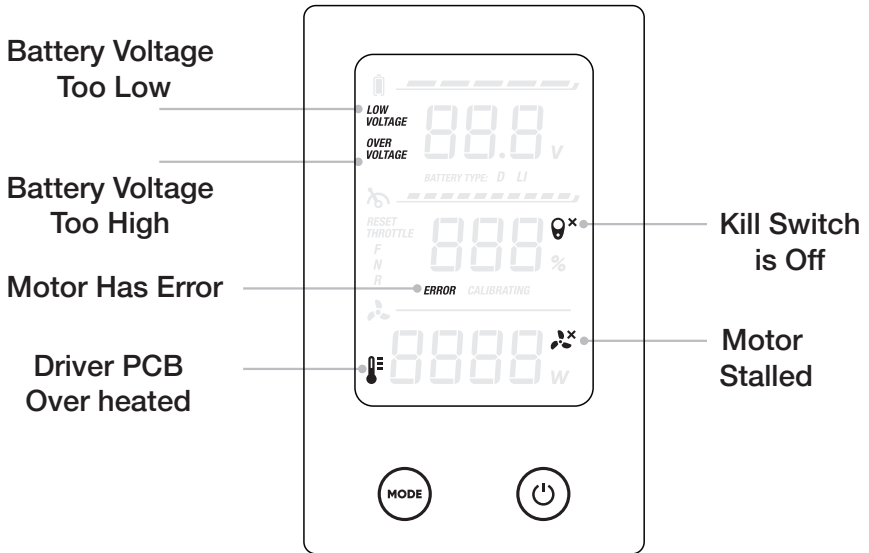

up and keep flashing. Please make sure the input voltage to the motor is correct (36V or 38.4V). Ensure the correct battery option is selected (D or Li).

Motor overheated: If the motor driver PCB is over heated, this icon will light up.

Motor stalled: If the motor is stalled, this icon will light up. Please disconnect from the battery and check to see if the propeller has been tangled in weeds or fishing line- these can also get wrapped behind the propeller. Clean the propeller and resume running.

## 5.4 Error Codes and Solutions

If there is an issue with the motor function, the display will show an error code to help diagnose the problem and find the solution.

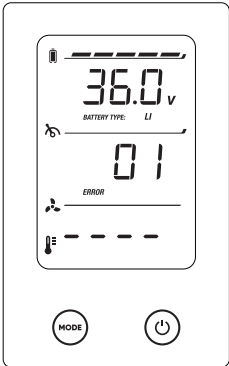
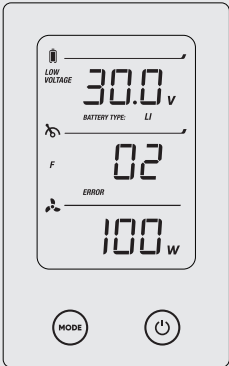
Error Code	Description	Solution
E-01	<p>The drive PCB is overheated.</p> 	<p>The motor drive PCB is overheated.</p> <p>Press the Power button for 2 seconds to reset the system. If the error code still shows up, wait until the motor cools down or contact customer support about repairs.</p>
E-02	<p>The voltage is too low or the battery is running up.</p> 	<p>The voltage of battery is too low to power the motor, replace or recharge the battery.</p> <p>The throttle will still work. Press the Power button for 2 seconds to reset the system and if the voltage is within operational range again the error code will disappear.</p>

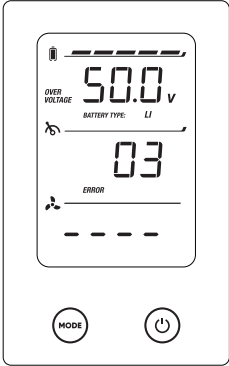
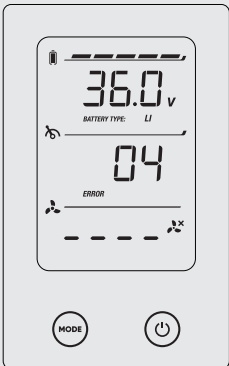
Error Code	Description	Solution
E-03	<p>Motor is overvoltage</p> 	<p>The voltage of the battery is too high to power the motor, if the battery is normal, make sure to setup correct battery type on the motor. Please follow <b>5.2.2 Switching Between Battery Types</b> to operate correctly.</p> <p>Press the Power button for 2 seconds to reset the system and if the voltage is within operational range again the error code will disappear.</p>
E-04	<p>Motor is stalled.</p> 	<p>The motor is stalled and stopped. Please lift the motor and check if there's anything blocked the propeller.</p> <p>Press the Power button for 2 seconds to reset the system. If the propeller is clear and the error still remains, contact customer support about repairs.</p>

## 6 Operation

### 6.1 Start the Motor

To start the motor please follow the steps below:

1. Place the magnet kill switch on the tiller.
2. Select the battery mode according to the battery type used.  
Please follow **5.2.2 Switching Between Battery Types** to operate correctly.
3. Press the power button on the panel.
4. You can now begin to power your motor.

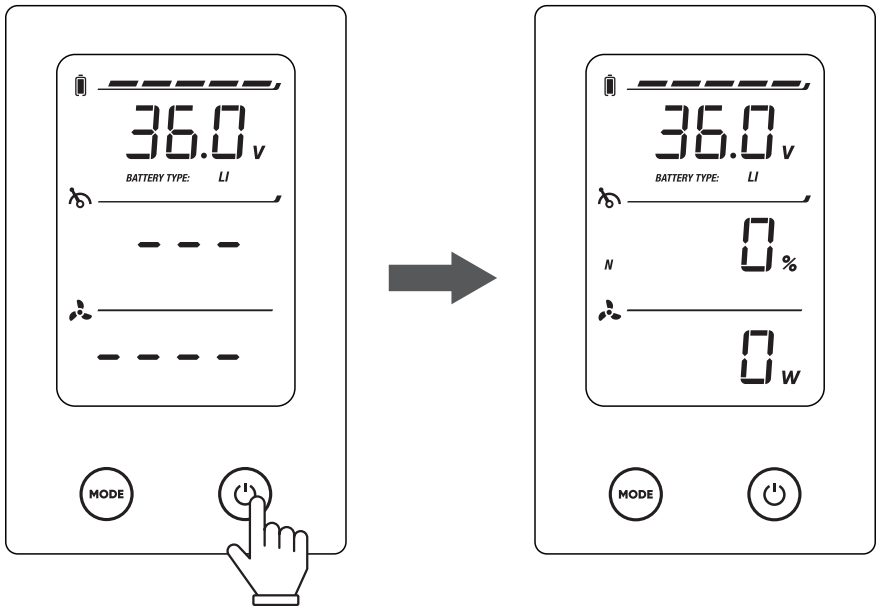

## 6.2 Travel Forward/Reverse

The motor's forward/reverse motion is controlled by the accelerator lever on the speed controller. Please refer to the diagram below which demonstrates how to operate.

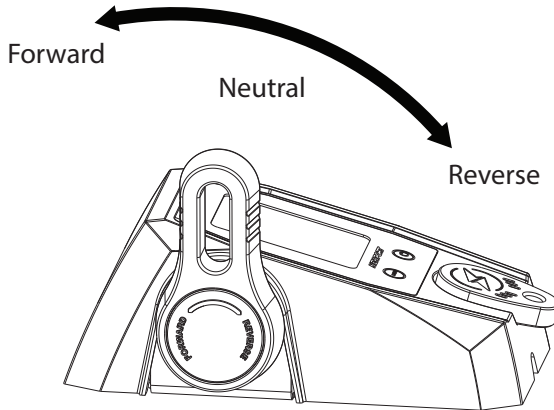

When switching to reverse, please pull the reverse lock cable to lock the motor and prevent it from tilting up and out of the water. If the motor tilts up, briefly engage the forward throttle while pulling the reverse lock; once the lock is engaged, return throttle to reverse.

If the reverse lock is hard to achieve, adjust your setup and try again.



### 6.3 Steering the Motor

While the motor is operating, pull the steering cords to control the kayak/boat's direction.

To make the kayak/boat turn left, pull the left cord on the steering triangle.

To make the kayak/boat turn right, pull the right cord on the steering triangle.

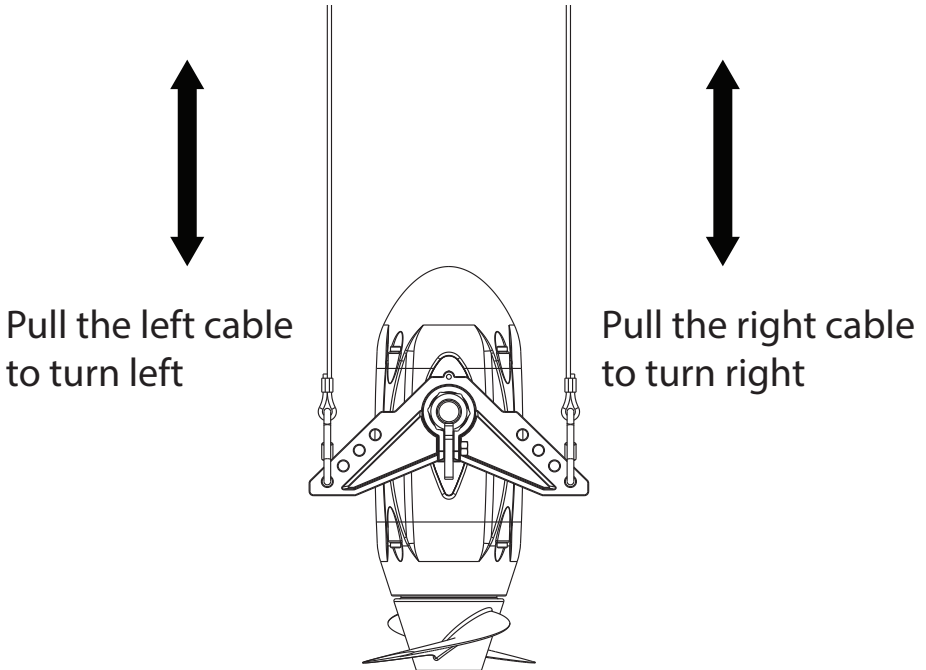

## 6.4 Emergency Stop

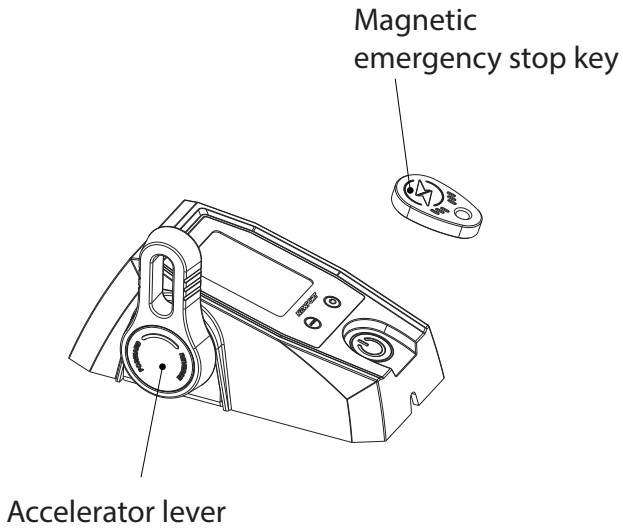

To stop immediately you can:

Pull off the magnetic emergency stop switch from the speed controller to stop the motor.

Move the accelerator lever on the speed controller to neutral to stop the motor.

If you want to restart the motor after the emergency kill switch is pulled off, move the accelerator lever to the neutral position, return the kill switch, and power on.

## 6.5 Stopping the Motor

To stop the motor, follow the steps below:

1. Move the accelerator lever on the speed controller to the neutral position.
2. Press the On/Off button on the speed controller.
3. Remove the emergency kill switch.

## 6.6 Tilting the Motor

When needed, the motor can be tilted up to stow away or to avoid underwater obstacles. To do this, pull the cord on the swing arm shown in the figure below until the motor pulls out of the water and secure the cord in the forward position, keeping the motor out of water. Make sure you secure the cord so that the motor will not drop down when you let go.

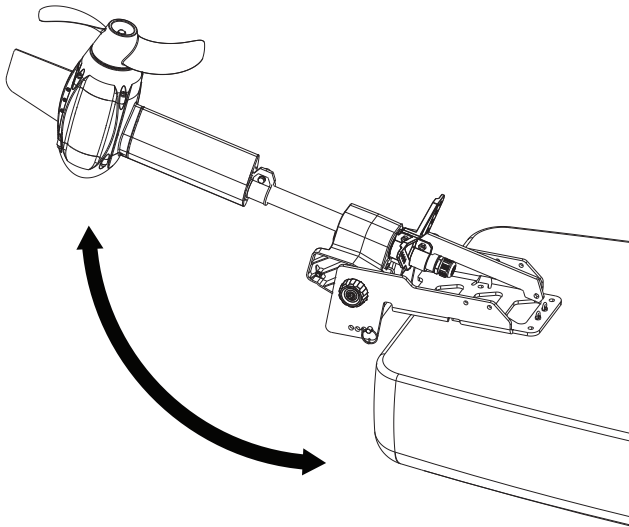

## 6.7 Finishing the Trip

When the trip is finished, please disconnect the motor from the battery and take the motor out of water. If the motor was used in the saltwater, thoroughly rinse the motor with fresh water. This will help prevent corrosion and salt buildup. Only wash the motor; do not get the speed controller wet.

## 6.8 Stow and Park the Motor

When the motor needs to be stowed and parked, tilt the motor up and use string or bungee cord to bind the motor on the bracket. Please use the figure below for reference.

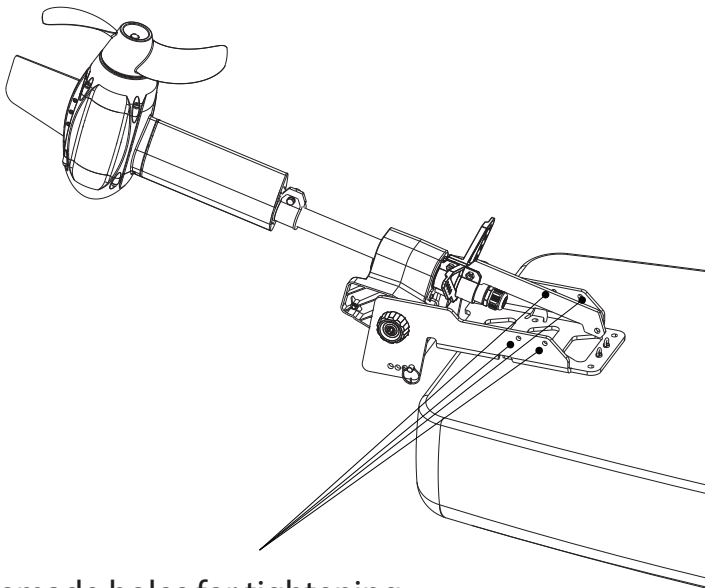

Premade holes for tightening  
motor in the stowed/ parked position

## 6.9 Remove the Motor From the Kayak

It is very easy to remove the motor from the bracket for travel, however you will want to leave the mount installed. Follow the steps below:

1. Move the accelerator lever to the neutral position, and turn off the motor.
2. Disconnect the motor from the speed controller and battery.
3. Detach all the control cords from the motor.
4. Loosen the knobs on the motor support drum, take out the drum shaft and lift the motor from the bracket.

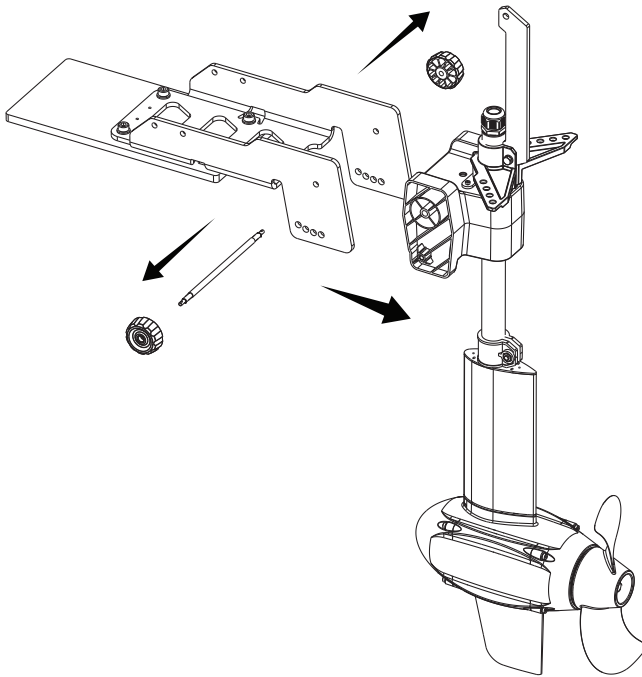

## **7 Care and Service**

### **7.1 Care of Motor Components**

- Please regularly follow all maintenance tips to keep your motor in optimal working condition.
- Do not start the motor in shallow water as it may damage the propeller.
- After each use, check between the plastic propeller and metal motor housing for fishing line, weeds, or other debris. ALWAYS DISCONNECT from power before working near the propeller.
- Lubricate all the pivot points with a non-aerosol lubricant. Never use an aerosol lubricant, as many types contain harmful propellants that can cause damage to various parts of your electric motor.

### **7.2 Corrosion Protection**

- After the motor is used in the saltwater, flush the motor thoroughly with fresh water.
- Before storing the motor, make sure the motor is completely dry and clean.
- Keep cable connectors and plugs in good condition.
- Use a wire brush to remove corrosion when necessary.

### **7.3 Care of Battery Usage**

- Check tightness of the battery lead connections.
- Never connect the wires to the wrong battery terminal. You must disconnect the battery during maintenance.
- Recharge batteries after each use. Follow the battery manufacturer's recommendations for battery maintenance.

## 7.4 Replacing the Fin

You can replace the fin component if it is damaged. To do this, follow the steps below:

1. Release the three M3 screws and nuts.

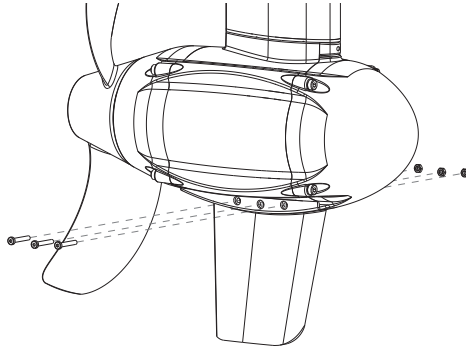

2. Remove the old fin component.

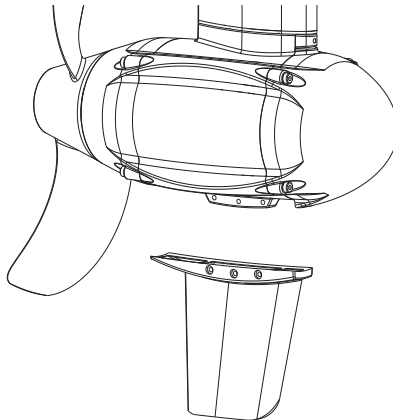

3. Insert the new fin component.
4. Insert three M3 screws and tighten them.

## 7.5 Replacing the Propeller

You can replace the propeller if it is damaged. To do this, follow the steps below with the assembly diagram:

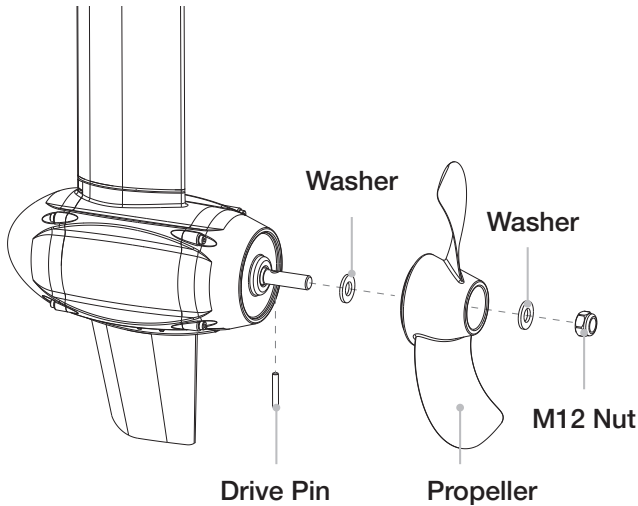

1. Attach the washer.
2. Insert the drive pin into the hole on the motor output shaft.
3. Rotate the propeller until the drive pin is seated correctly in the corresponding channel on the backside of the propeller.
4. Place the washer on the motor shaft after the propeller.
5. Tighten the hex locknut with 17mm socket wrench.



## 7.6 Recalibrate the Throttle

You can recalibrate the throttle when the throttle display is inaccurate. To do this, follow the steps below:

Press and the MODE button for 5 seconds, the controller will enter the throttle recalibration mode. You will notice the CALIBRATING sign starts to flash.

While the screen displays the F icon, move the handle to the full throttle forward position.

Press the MODE button again.

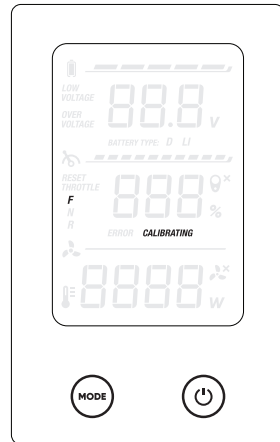

While the screen displays the R icon, move the handle to the full throttle reverse position.

Press the MODE button again.

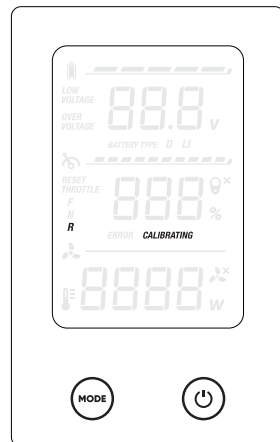

While the screen displays the N icon, move the handle to the Neutral (middle) position.

Press the MODE button again. And the throttle recalibration is complete.

You will notice the CALIBRATING sign stops to flash, press the POWER button to exit the recalibration mode.

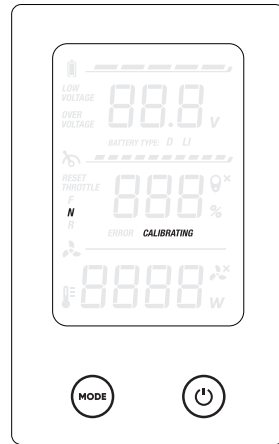

When the CALIBRATING sign flashes, it means the recalibration is not finished yet, exiting the throttle recalibration mode will not change the current throttle setup.

To exit the throttle recalibration mode at any steps during the process, press the POWER button.

## **8 Customer Support**

If you have questions that are not answered in this manual or your troubleshooting is not successful, please contact Newport Vessels! Our California based customer service team is standing by to assist you.

### **Customer Support**

**Phone: (866)721-0002**

**E-mail: [support@newportvessels.com](mailto:support@newportvessels.com)**

**Hours: 8:30am-4:30pm Pacific Time (west coast)**