



Electric Trolling Motor

Pontoon Series

User's Manual

Please read and retain this manual before using product

REACH RoHS



Contents

1	General Information	4
2	Specifications	4
3	Wiring and Battery Recommendations	5
3.1	Battery Type.....	5
3.2	Circuit Protection.....	5
3.3	Cable Size.....	5
4	Safety Information	6
5	First Time Running	7
6	Mounting Bracket Installation	8
7	Motor Operation	12
7.1	Battery Connection Method (12 Volt only)	12
7.1.1	Connection With One Battery (12V DC).....	12
7.1.2	Connection With Two Batteries in Parallel (12V DC)...	12
7.2	Battery Connection Method (24 Volt only)	13
7.2.1	Connection With Two Batteries in Series (24V DC)....	13
7.3	How To Control The Motor	13
7.3.1	On/Off Speed Control.....	13
7.3.2	Adjust Handle Position.....	14
7.3.3	Battery Level Indicator.....	14

7.3.4	Adjusting Motor Depth	14
7.3.5	Adjusting Steering Tension	14
8	How to Replace the Propeller	15
9	Daily Maintenance	16
10	Trouble Shooting	17
10.1	Loss of Power	17
10.2	Motor Makes Excessive Noise or Vibration.....	17
10.3	Motor Fails to Run.....	17
10.4	Motor Loses One or More Speeds.....	18
11	About Circuit breaker	18
11.1	Function of the circuit breaker.....	19
12	Declaration of Conformity for Recreational Craft	20
13	Customer Support.....	20

1 General Information

Thank you for purchasing our product. We hope that you enjoy it!

Newport Vessels trolling motors are designed and developed by professional engineers and the design is continually honed and improved. There are a wide range of Newport Vessels outboard motors, from 36lbs to 86lbs, to suit every customer’s requirements and uses.

Please read and retain this manual before using this electric motor. This manual contains information that describes the procedure for safe operation and daily maintenance of your electric motor. Safe operation will prevent personal injury and damage to the product.

2 Specifications

Item No.	Thrust in LBS	Thrust in KG	Input	Input Power
Pontoon-55	55	25.0	12V, 52A	624W
Pontoon-86	86	37.2	24V, 48A	1152W

Since speed depends on many factors, such as loading, water condition, hull type, wind speed, etc., it is difficult to give accurate speed ratings. Instead refer to the thrust and power ratings provided above.

3 Wiring and Battery Recommendations

3.1 Battery Type

Recommended battery(s): 12-volt Deep Cycle battery or Marine battery. To extend running time, either a larger capacity or an additional battery can be used. See section on battery connection method. NOTE: 86lbs model requires a 24-volt battery.

3.2 Circuit Protection

It is recommended to install a manual reset circuit breaker in the electric outboard motor leads within 72 Inches (1.8m) of the battery(s).

3.3 Cable Size

If extending the standard battery cable supplied with the product, Newport Vessels recommends the use of 8-gauge wire (13mm² wire).

⚠ WARNING Be sure all switches are in the OFF position before connecting to battery or batteries. Electrical arcing near the battery could cause an explosion. The battery produces hydrogen and oxygen gases while charging. This potentially explosive mixture escapes through the fill vent cell caps and may form an explosive atmosphere around the battery for several hours after it has been charged. Electrical arcing or flames can ignite the gas and cause an explosion, which may shatter the battery and could cause blindness or other serious injury.

⚠ WARNING Batteries contain sulfuric acid, which can cause severe burns. Avoid contact with skin, eyes and clothing.

4 Safety Information

- Do not allow children to operate the electric outboard motor.
- Do not modify the unit in any way or add accessories not intended for this product.
- Never fully submerge the unit. If unit is accidentally submersed, disconnect battery and leave to dry.
- To prevent accidental damage to the fiberglass shaft, do not over tighten the mounting bracket.
- Only use this product between the temperatures -4F° to +113F° (-20°C to +45°C).
- **User(s) should always wear approved life jackets.**

⚠ WARNING Always disconnect power from the motor when replacing propeller, removing debris around the prop, charging batteries, transporting boat, or when the motor is not in use.

5 First Time Running

1. Place Electric Outboard onto the back of the vessel in the Stow away position.
2. Loosely tighten the Transom Mounting Screws until they grip the Transom Mount.
3. Press the Tilt Lever and slowly let the motor enter the water.
4. Use the Depth Adjuster Collar to adjust the height of motor. Recommended running depth is between 6in to 12in (15cm to 30cm) below the waterline.
5. When you are satisfied that the motor is at a safe depth, and isn't too close, or in danger of hitting the bottom of the water way, you may proceed to tighten the Transom Mounting Screws.
6. Once this is done it should be safe to connect the battery to the motor. Ensure that the twist grip is in the neutral position and that the nuts are tight on the terminals to prevent a poor connection.
7. Select the desired speed and direction using the twist grip on the tiller arm.
8. Do not go from full forward speed to full reverse speed without letting the propeller stop turning first or motor damage may occur.

6 Mounting Bracket Installation

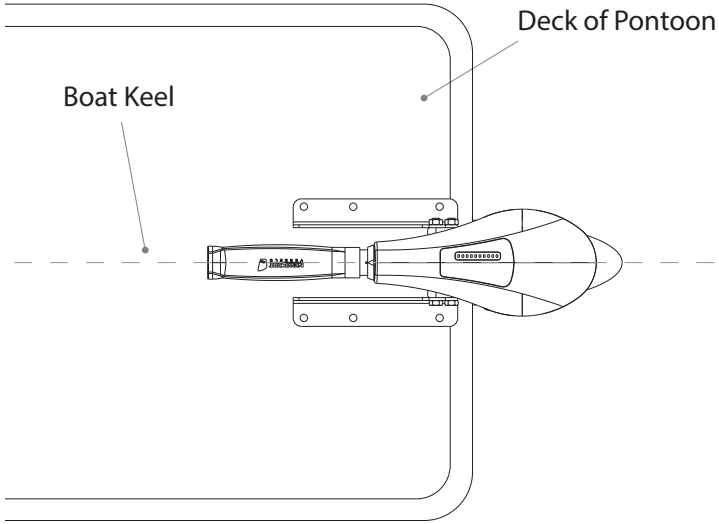

We recommend installing the motor along the centerline or keel of the pontoon boat. Before the installation, remove the motor assembly first and place the mounting bracket at the desired position.

⚠ WARNING Before installing the mounting bracket make sure the motor is disconnected to the battery or other power source.

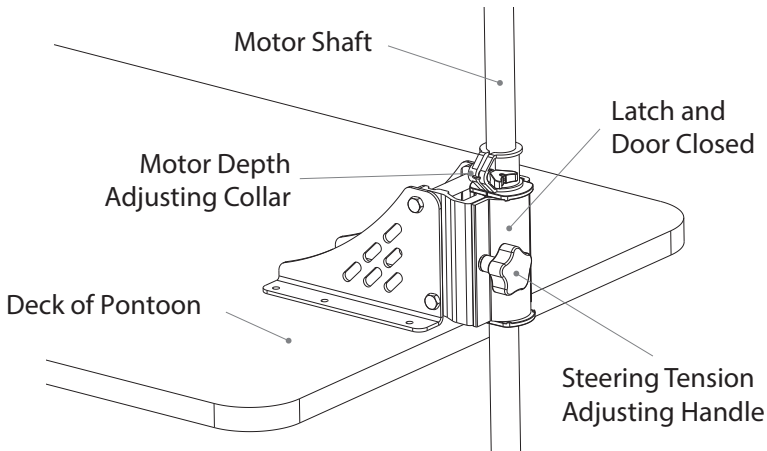

Loosen the steering tension adjusting handle and open the latch and door to remove the motor assembly from the mounting bracket.

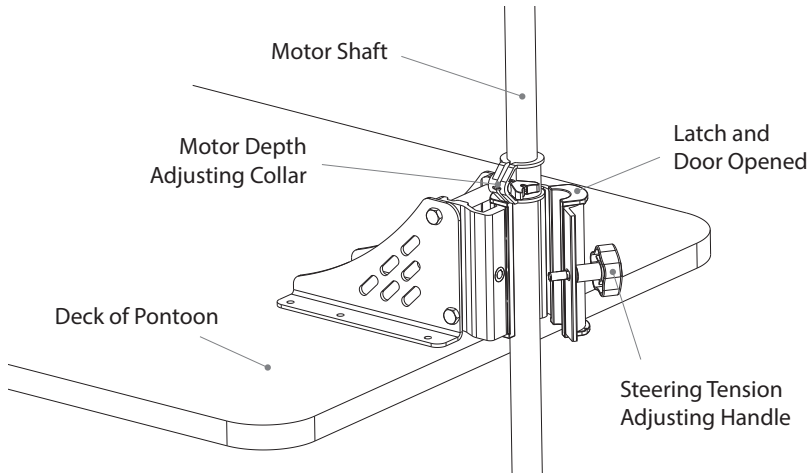

Close the latch and door on the mounting bracket and loosely tighten the steering tension adjusting handle. Place the motor aside.

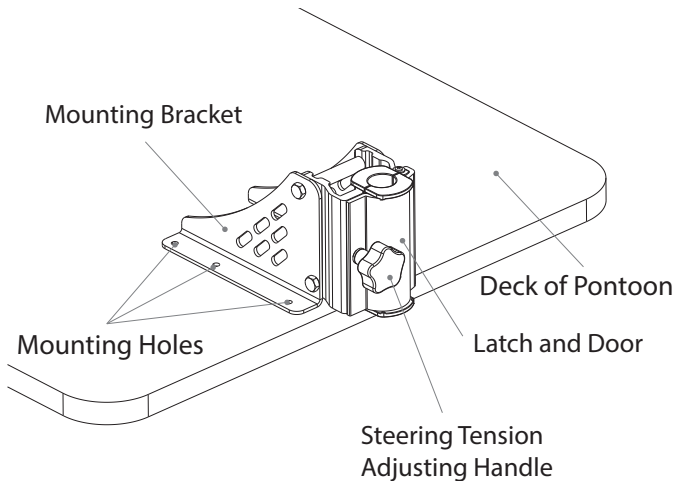

You can choose from two options to secure the mounting bracket.

Option1: Drill holes on the deck of the pontoon boat through the mounting holes on the mounting bracket. Insert the M6 x 75 screws, washers, and nuts as indicated in the diagram below and tighten the screws to secure the mounting bracket.

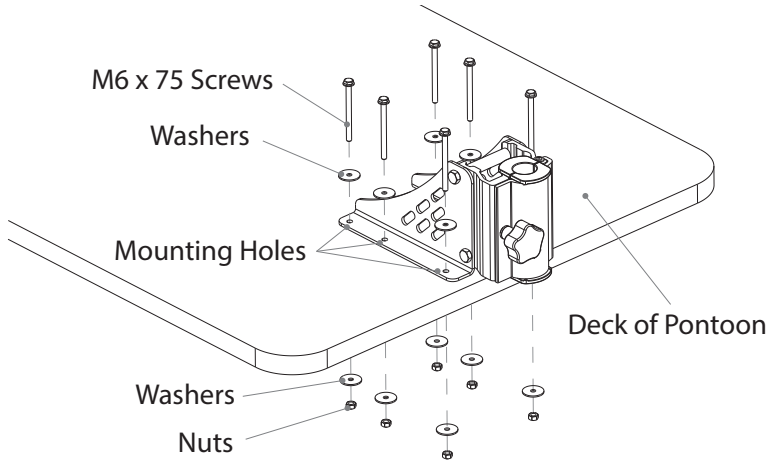

Option2: Place the M6 x 60 Self-tapping screws and washers as shown in the diagram below and tighten the screws directly into the deck to secure the mounting bracket. (Only for use on deck materials that can safely accept self-tapping screws.)

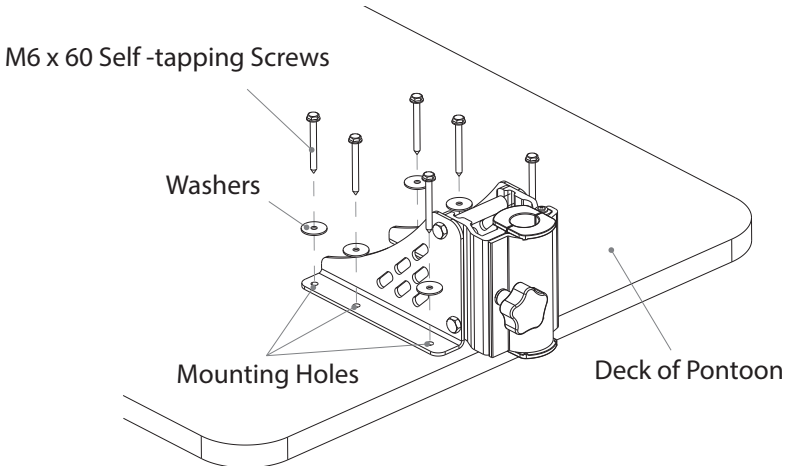

Loosen the steering tension adjusting handle to open the latch and door, and replace the motor assembly inside as shown below, making sure the motor depth adjusting collar is above the mounting bracket.

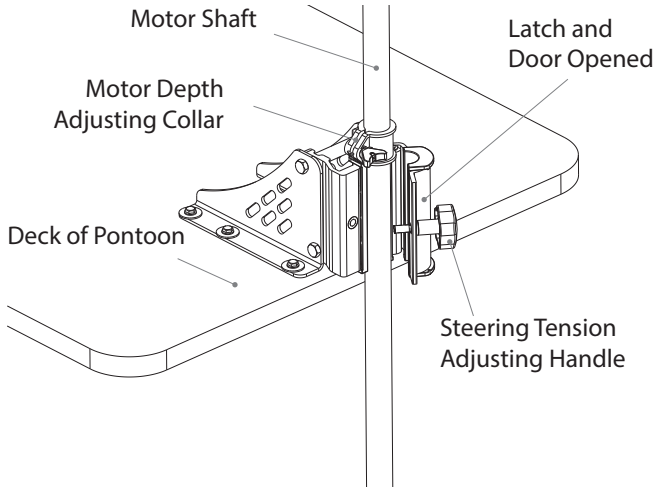

Close the latch and door and tighten the steering tension adjusting handle, making sure the motor assembly is in place properly.

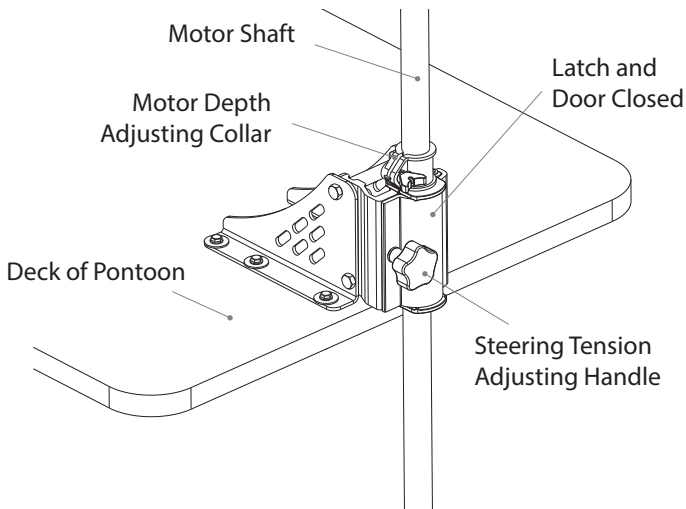

7 Motor Operation

This product does not include batteries; please choose a battery with 12V (24V for 86LBS motor output to fit this motor). The recommended type of battery is a deep cycle battery or marine battery, as they will last much longer and are specifically designed for this application.

7.1 Battery Connection Method (12 Volt only)

7.1.1 Connection With One Battery (12V DC)

The red wire should connect to positive; the black wire should connect to negative. (It is recommended to install circuit breaker on the positive wire.)

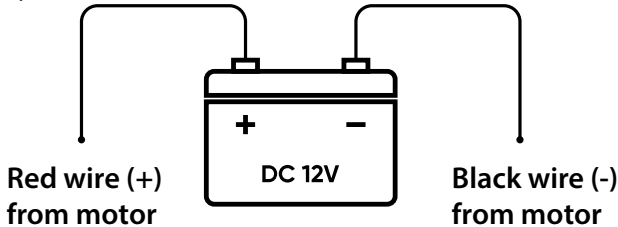

7.1.2 Connection With Two Batteries in Parallel (12V DC)

The red wire should connect to positive; the black wire should connect to negative. (It is recommended to install circuit breaker on the positive wire.)

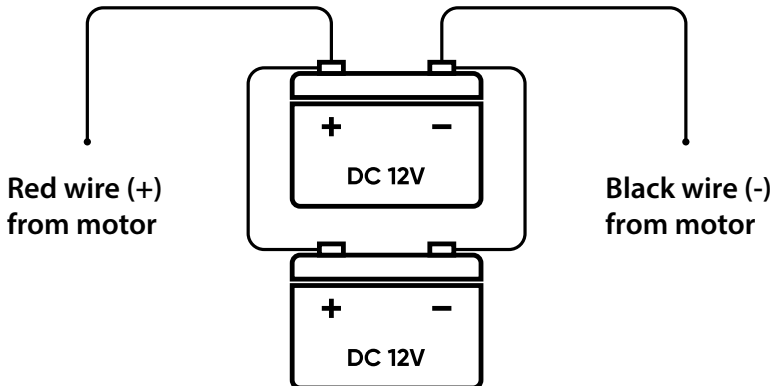

7.2 Battery Connection Method (24 Volt only)

7.2.1 Connection With Two Batteries in Series (24V DC)

The red wire should connect to positive; the black wire should connect to negative. (It is recommended to install circuit breaker in line with positive lead.)

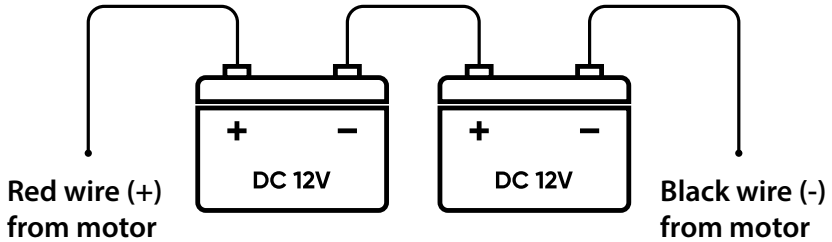

⚠ WARNING Remember to always disconnect from the battery(s) once the motor leaves water as a rotating propeller can cause personal injury.

7.3 How To Control The Motor

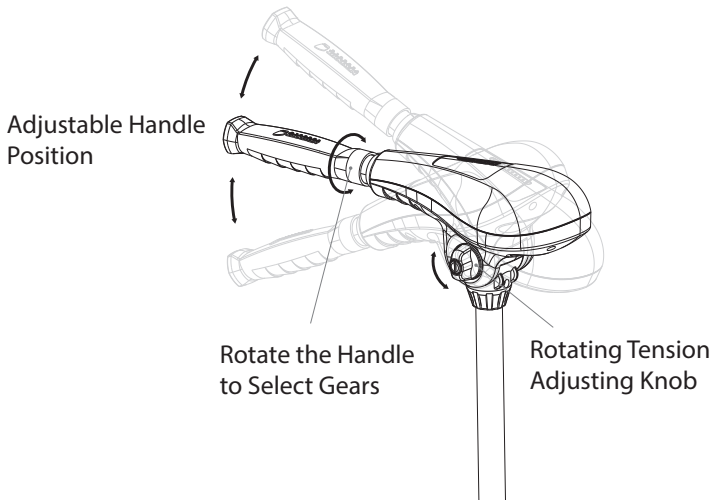

7.3.1 On/Off Speed Control

Rotate handle clockwise to obtain any of the 5 forward speeds. Rotate

handle counter-clockwise for any of the 3 reverse speeds. To stop the motor from running, position the handle matching the arrow marker on level 0.

7.3.2 Adjust Handle Position

To adjust the position of the handle, loosen the rotating tension adjusting knob, adjust to desired position, and then re-tighten. Tighten the rotating tension adjusting knob to preferred level of resistance, or all the way to lock the handle.

7.3.3 Battery Level Indicator

There are ten LED lights on the top cover. When seven LED's are out, the meter is indicating that the input voltage is less than 9.5V (normal voltage draw is 12V). At this point it is advised to disconnect the motor from the battery to prevent damage to the battery and recharge.

7.3.4 Adjusting Motor Depth

Position the depth adjustment collar so the propeller blades are sub-merged 6inches - 12inches (15cm - 30cm) below the surface of the water.

7.3.5 Adjusting Steering Tension

Tighten or loosen the steering tension adjusting handle to increase or decrease the steering tension. You can also lock the motor direction by tightening the steering tension adjusting handle firmly.

⚠ WARNING Remember to wash the motor with fresh water after being used in salt water, as it can greatly reduce the possibility of corrosion.

8 How to Replace the Propeller

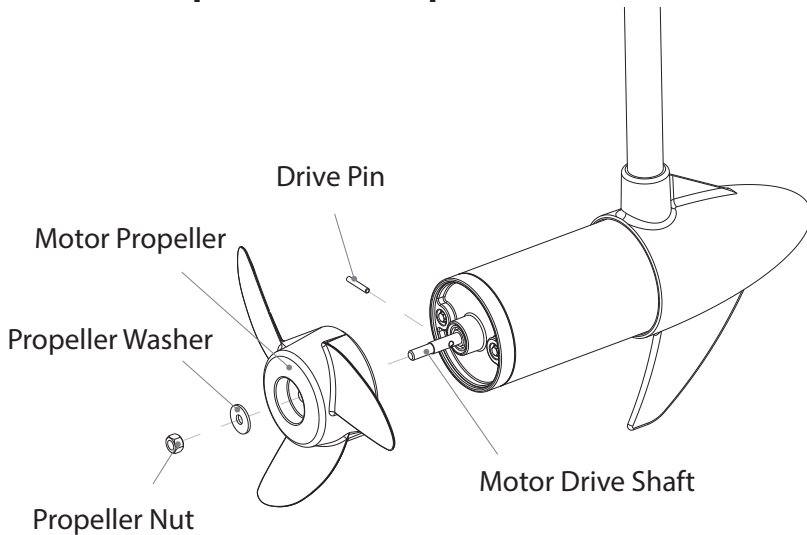

⚠ WARNING Make sure that the motor has been disconnected from batteries before handling the propeller.

Please visit <https://newportvessels.com/propeller-installation-guide/> to get more details.

Hold the propeller blade and loosen the propeller nut using the prop spanner supplied or a set of needle-nose pliers. Remove the propeller nut. Pull the propeller straight off. If prop is stuck, grasp one blade with one hand and tap on the backside of the opposite blade lightly with a rubber mallet, until the propeller comes off. If the propeller pin is bent, replace it. Align the new propeller with the propeller pin. Reinstall the propeller nut and tighten firmly by hand, then tighten with spanner another 1/4 turn.

⚠ WARNING Do not strike bent prop pin with hammer to remove pin. Damage to motor armature may occur that would not be covered by warranty.

9 Daily Maintenance

1. Check behind the propeller after each day for weeds, fishing line or other debris that may get wrapped behind the propeller.
2. Lubricate all the pivot points with a **non-aerosol** lubricant. Never use an aerosol lubricant as many types contain harmful propellants that can cause damage to various parts of your electric motor.
3. Check tightness of the battery lead connections.
4. Visually check condition of main battery cables.
5. Inspect for loose or corroded wiring connections.
6. Always thoroughly rinse your electric outboard motor with fresh water after every use in salt water. Only rinse the areas that have been in contact with salt water, avoid getting the top cover wet as this may damage the circuitry inside.
7. Inspect tightness of all nuts, bolts and screws.
8. Recharge batteries after each use. Follow the battery manufacturer's recommendations for battery maintenance.
9. During freezing temperatures, when your electric motor is not being used, it should be stored in an area where it will not freeze.
10. Never connect the wires to the wrong battery terminal. You must disconnect the battery during maintenance.

10 Trouble Shooting

10.1 Loss of Power

- Propeller may be damaged. Remove propeller, clean and replace.
- Battery connections may be corroded.
- Battery has low voltage. Recharge.
- Battery may be faulty, recharge and check.
- Insufficient wire size from battery to motor wiring. 6 gauge wire/ 13mm² thickness recommended.
- Bad or faulty connection in boat wiring or electric motor wiring.
- Permanent magnet cracked or chipped. Motor will whine or grind.

10.2 Motor Makes Excessive Noise or Vibration

- Propeller may be damaged or unbalanced.
- Check to see if propeller is secured.
- Bent armature. Remove propeller, set at medium speed, turn unit on and check for armature wobble.
- Turn propeller by hand. It should turn freely with a slight magnetic drag.
- Bearing bushes may be worn out.

10.3 Motor Fails to Run

- Check fuse circuit breaker on boat for electric motor.
- Check for loose or corroded connections.
- Check plug for loose or bad connection.
- Test main rotary switch.
- Turn prop by hand. It should turn freely with a slight magnetic drag.

- Total battery failure. Recharge and check voltage.
- Propeller damaged.

10.4 Motor Loses One or More Speeds

- Loose wire on rotary switch. Check wiring diagram.
- Loose connection in top housing.
- Rotary switch damaged.
- Speed coils in lower unit may be burned.

11 About Circuit breaker

During the usage of the electric outboard motor, the propeller can sometimes get stuck in weeds, fishing lines, or fishing nets. Sometimes, due to the variance of the water depth, the propeller can become covered in silt. If those situations occur, quickly disconnect the battery and clean the propeller. (Please DO NOT increase the thrust of electric outboard motor to solve the problem, or it may cause permanent damage to the electric outboard motor.)

The characteristics between the electric outboard motor and gasoline outboard motor are different. If the propeller of the motor gets stuck, the gasoline outboard motor will shut down to not cause any permanent damage to the motor itself. However, the electric outboard will draw extremely large current due to the motor stall and can generate large amounts of heat that can damage important components in the motor such as switch, rotor and other connecting parts or even cause serious battery explosions.

In some muddy water areas, it can be hard for the user to recognize that the motor is stalled. To prevent these situations from occurring, it is strongly recommended to use circuit breaker to protect the electric outboard motor. If the current draw of the electric outboard motor exceeds the limit of normal usage, the circuit breaker will cut off the power automatically to prevent any possible damage to the electric outboard

motor. The circuit breaker has a reset button and is therefore reusable.

To prevent the rotor coil damage from exceeding current, it is highly recommended to use a circuit breaker to protect electric outboard motor.

11.1 Function of the circuit breaker

During the usage of the electric outboard motor, when the propeller is stuck by the weeds, small stones, fishing lines, etc., the circuit breaker will cut off the power automatically to prevent the damage of the motor's electrical parts.

If the circuit breaker cuts off the power, please disconnect the battery first, then check and clear any obstacles. Finally, press the reset button on the circuit breaker and reconnect the battery. The electric outboard motor will now be able to continue functioning properly.

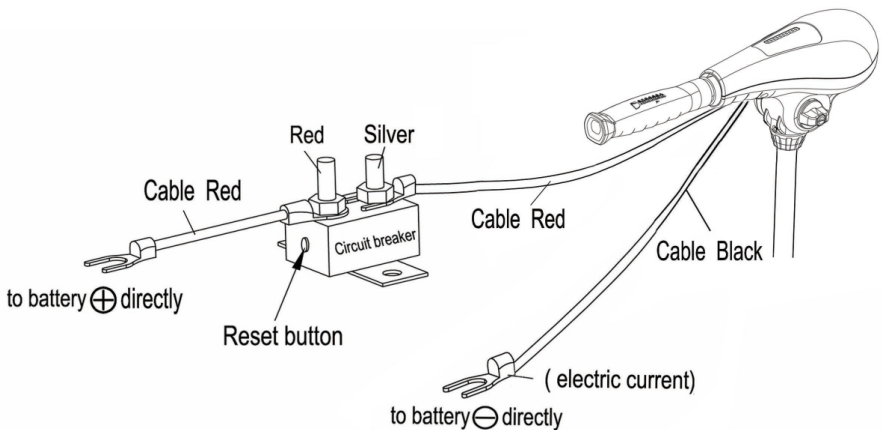

12 Declaration of Conformity for Recreational Craft

**Propulsion Engine with the requirements of Directive
89/392/EEC as amended by 89/336/EEC.**

Engine type approved according to: Directives 89/392/EEC, 89/336/EE

Description of Engine(s) and Essential Requirements

Engine Type: Outboard Engine

Fuel Type: Electric

This declaration of conformity is issued under the sole responsibility of the manufacturer. I declare on behalf of the manufacturer that the motor(s) is (are) in conformity with the type(s) for which above mentioned EC, EMC and ROHC type-examination or type approval certificate(s) has (have) been issued and it will meet the requirements of Directive 89/392/EEC, 89/336/EEC as amended when installed in a recreational craft, in accordance with the manufacturer's supplied instructions.

13 Customer Support

If you have questions that are not answered in this manual or troubleshooting is not successful, please contact Newport Vessels! Our California based customer service team is standing by to assist you.

Customer Support

Phone: (866)721-0002

Email: support@newportvessels.com

Hours: 8:30am-4:30pm Pacific Time