

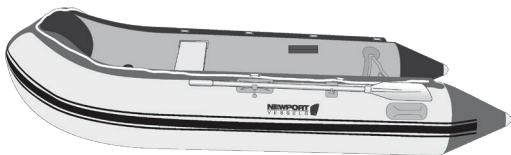

**OWNER'S MANUAL AND
SAFETY INSTRUCTIONS**



⚠ WARNING

WARNING: This product contains chemicals known to the State of California to cause cancer and birth defects or other reproductive harm.

WWW.NEWPORTVESSELS.COM

Toll-free: (866) 721-0002



Dear Valued Customer,

Congratulations! You are now the proud owner of a Newport Vessels inflatable boat.

This full owner's manual can be downloaded from the Newport website (www.newportvessels.com/downloads). In addition, we invite you to visit the Newport Vessels "Video Library" or "FAQ's". We have put together an extensive collection of short video tutorials as well as answers to FAQ's. We've found that videos can be more detailed, viewed faster, and a lot of fun to watch, so we invite you to browse the Video Library at the link listed below.

1. Visit: www.newportvessels.com
2. Hover over the top heading: "ABOUT NV"
3. Click "Video Library" or "FAQs"

If you have any questions or concerns, send us a chat message or give us a call!

Enjoy your Newport Vessels inflatable boat and happy boating!

Sincerely,

The Newport Vessels Team

CONTENTS

1. Boat Models & Specs	6
2. Conformity Declarations	6
3. Parts	6
4. Assembly	7
Assembly Preparation	7
Seat Installation	8
Finish Inflation	9
Oar Assembly	9
Disassembly	9
Air Pressure Guidelines	10
Air Chamber Failure	10
5. Operation Information	10
Operation Safety	10
6. Safety Guidelines:	11
Aspects of Environmental Protection	12
Loading	12
Operation: Rowing	12
Operation: Outboard Motor	12
Towing - Anchoring - Mooring	13
Water Hazards	13
Beaching	13
Storage	13
Use in High Altitudes	13
7. Repair Procedure	14
Small Tears, Cuts, and Punctures	14
Large Repairs of Skin, Seams, Bulkheads, and Transom	14
EC Declaration of Conformity	14
8. Warranty	14
Warranty Claim	14
9. Glossary of Terms	15

1. BOAT MODELS & SPECS

AIR FLOOR MODELS	INFLATED LENGTH	INFLATED WIDTH	CHAMBERS	WEIGHT	MAX POWER	MAX LOAD	MAX PERSONS
CARMEL	7'7"	4.5'	3 + 1	80 lbs	4 HP	805 lbs	2
SEASCAPE	9'	5'	3 + 1	93 lbs	10 HP	1067 lbs	3
SANTA CRUZ	10'	5'	3 + 1	99 lbs	15 HP	1124 lbs	4

2. CONFORMITY DECLARATIONS

EN ISO 6185 for boats below 2.5m length EC Approvals for boats larger than 2.5m according to EC directive 94/25/EC.



ATTENTION! Do not use a compressed air source (such as a compressor) to inflate boats. Over-inflation through the use of compressed air may result in ruptured seams and/or bulkheads.

3. PARTS

Before starting, layout all of the box contents to ensure that you have all of the parts.

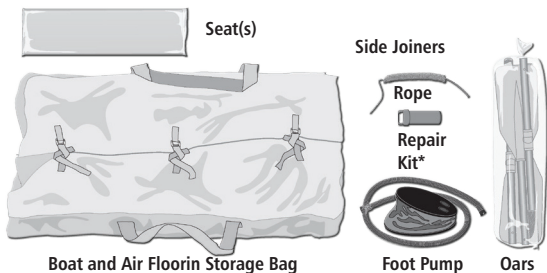

4. ASSEMBLY

ASSEMBLY PREPARATION

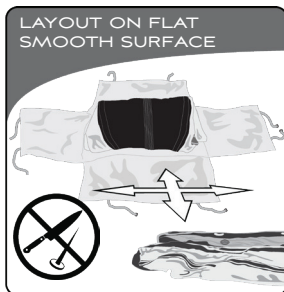

- Find a smooth flat surface.
- Remove any sharp objects from the flat surface where the boat will be assembled and inflated.
- Unfold and spread out the boat flat.

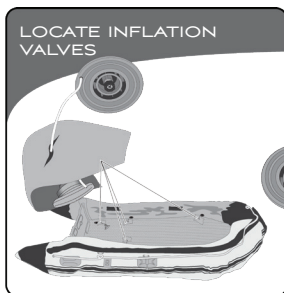

- Locate the inflation valves which are tagged with a bright orange flag.
- The valve retainer cap is inside of the orange flag.

NOTE: The one-way valve makes inflation easy. The inner valve design allows air to flow into the hull but not out. Make sure the plastic stem is in the lock position for inflation, by pushing it in and turning clockwise. To unlock the valve and release air, push in and turn counter-clockwise.

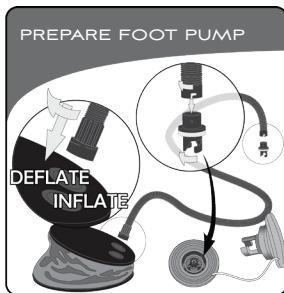

- Attach the nozzle which is fixed to the hose to the pump by screwing it clockwise into the port marked "INFLATE".
- Attach the nozzle with the twist lock (as shown) to the other end of the hose.

NOTE: When you want to prepare the boat for storage, attach the fixed end to the port marked "DEFLATE" to pump to remove all air from the boat.

NOTE: When using the boat for the first time, fully inflate it by attaching the foot pump to each of the hull chamber valves, one at a time, and when pumping, ensure that a balance of pressure between the chambers is maintained until the boat has been fully inflated.

When the boat is fully inflated, unscrew the valves and allow approximately 70% of the air to escape. Close valves again, and continue assembling the boat.

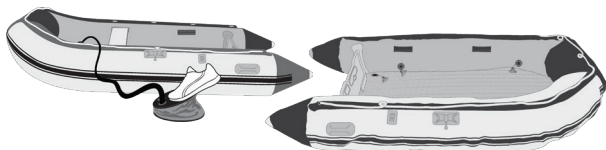

Learn more in the "Air Pressure Guidelines" on page 10

ATTENTION! For the rest of the assembly process - the boat should only be filled to approximately 30% air capacity.

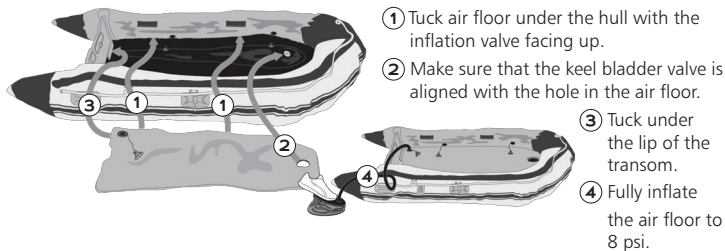

SEAT INSTALLATION

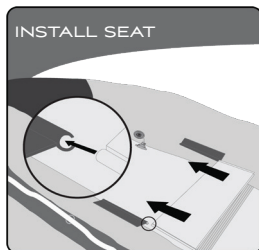

- Install the seat (or seats) by sliding the seat on to the seat mounts on either side of the boat.
- Slide both sides simultaneously until centered on the mounts.
- The seat will be held securely in place once the boat is fully inflated.

FINISH INFLATION

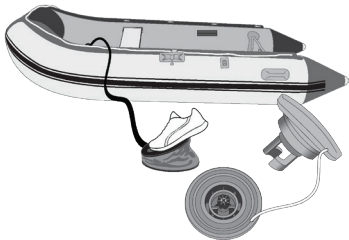

- Finish inflating the air chambers one after the other in order to maintain equal amount of air.
- Install valve caps.
- Inflate the keel and screw on valve cap.

NOTE: DO NOT inflate any chamber to full capacity at one time.

NOTE: Make sure the plastic stem is in the lock position. Screw cap on each valve.

OAR ASSEMBLY

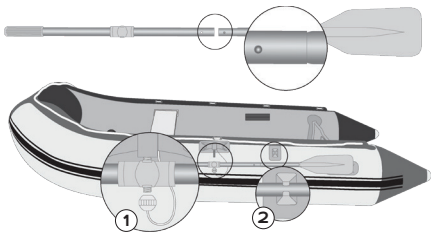

- Push two halves of the oar together with button aligned with hole.
- Push button in and continue sliding halves together until the button pops up.

- ① Secure oar to the oar attachment fixture.
- ② Snap oar into the oar keep when not in use.

DISASSEMBLY

1. Unscrew all air valves to deflate the boat.
2. Remove the seat.
3. Remove air floor and deflate.
4. Using the foot pump as a suction device, remove excess air from each chamber, including air floor.
5. With the boat now flat, ① fold the back end cones over the transom. ② Fold the hull sides in toward the center. ③ Roll the transom over itself toward the bow.

NOTE: The boat should be clean and dry before rolling up for storage. Remove any sand and debris.



CLEANING PROCEDURES

Rinse your boat, after each use. At the end of a season, wash it completely with soapy water or with a mild detergent. Rinse, let dry then apply talcum powder before folding up the boat. Store in a dry place.

Important: DO NOT use a vinyl-preserving agent on fabric surfaces. Chemicals in such agents will dry out the fabric.

AIR PRESSURE GUIDELINES

1. Inflate the boat with the foot pump supplied.

NOTE : When using a foot pump, the boat can never be over-inflated. If using an electric inflator, finish the inflation procedure with the pump supplied to obtain the correct inflation pressure.

2. The maximum inflation pressure is 3.6 PSI for the boat and 4.5 PSI for the keel and 8 PSI for the inflatable floor. Depending on climate and operating conditions, the pressure may require monitoring during boat use to maintain a correct inflation level.
3. A boat inflated for 2 to 3 days may lose pressure and require topping off to the correct operating pressure.

WARNING: DO NOT use a compressed air source (i.e. compressor) to inflate the boat. Over-inflation may result in ruptured seams and/or bulkheads.

4. When inflating, maintain a balance of air between air chambers to prevent damage to air chamber bulkheads.

AIR CHAMBER FAILURE

1. Should an air chamber get punctured, shift the weight to the opposite side. Prevent, as much as possible, further air leakage (by hand or with webbing) and immediately proceed to the nearest shore.
2. Check that on-board loads are not chafing or puncturing the boat skin.

5. OPERATION INFORMATION OPERATION SAFETY

Beware of offshore winds and currents!

It is the responsibility of the boat's operator to know all laws applicable to boats and to comply with those laws when equipping and operating the boat.

Rules and regulations may vary depending on the following conditions: The location of the boat's operation and the requirements of local authorities; the use of the boat, the particular time of the day during which the boat is being used, the conditions under which the boat is being operated, and the size, speed, course, kind of boat (power, oars, etc.) and mode of operation.

In addition to knowing and following the applicable laws, please note the following:

1. Each passenger should wear the appropriate clothing and wear an approved life jacket.
2. Ensure that all basic equipment is on board the boat, including paddles / oars and an inflation pump. Be aware of the possible necessity of additional safety equipment.

3. A boat should not be operated by an individual under the influence of drugs or alcohol.
4. Weight must be distributed evenly. If your motor-equipped boat is lightly loaded, do not accelerate suddenly. Stability and handling problems can occur if the operator mishandles the craft.
5. The carrying capacity, engine power, and maximum weight must not be exceeded.
6. Outboard motors are dangerous and can cause injury and death when improperly operated. Never equip or operate your boat with a motor that is not approved for use with the boat. Never approach a swimmer in the water or allow a swimmer to approach the stern of the boat while the engine is running.
7. Attention should be given to winds, currents, and tides, which can affect fuel consumption.
8. When boating in unknown waters, it is always a wise precaution to obtain local knowledge before setting out.
9. Always tell someone your time and place of departure, your proposed route and the time you expect to return.
10. The display of navigation lights may be required. The user should ensure that the boat should not be operated during darkness or other hazardous weather conditions unless correct navigational lighting has been fitted and is operating properly.
11. Safety courses on boat handling are available in most countries from national or local organizations. Operators should acquaint themselves with the general rules of the

waterways and the local water conditions before taking a boat out.

12. On extended voyages due consideration must be given to safety equipment such as flares, first aid kit, anchors, etc.

6. SAFETY GUIDELINES:

When boating: learn and respect local regulations and practices. Do not neglect the safety rules, this could jeopardize your life and the lives of others.



CAUTION! DO NOT EXCEED AUTHORIZED NUMBER OF PERSONS OR WEIGHT.



NO ALCOHOL / DRUGS: Do not drink alcohol or take drugs before or while operating your boat. Ensure that all passengers remain sober.



If using outboard motor, Always use the stop switch lanyard: Your outboard comes equipped with a stop switch safety lanyard to prevent a runaway boat in case the operator falls overboard. Attach it to the operator, it could save a life. **THE PROPELLER IS DANGEROUS. KEEP HANDS AWAY FROM THE PROPELLER.**



Use personal flotation device (PFDs): PFDs are compulsory equipment. Wear them.



Make sure your passengers remain seated: sitting on the buoyancy tubes may be comfortable at rest or at low speeds provided your passengers use the grab line. At planing

speeds, in rough water or during sharp turns, all passengers should position themselves in seats or on the floor. We will take no responsibility if this warning is disregarded.



No bow riding: Bow riding is illegal in most areas and is extremely dangerous. Be especially careful when docking: arms and legs may be injured if they are outside the boat.



Keep clear of swimmers and divers: Always avoid areas where divers/swimmers are in the water. Keep a sharp lookout especially when operating near

beaches and launch sites. Shut off the motor when operating near someone in the water.

OBSERVE THE RULES OF THE SEA. LEARN TO CONTROL YOUR BOAT CORRECTLY AND TO RESPECT THE NAVIGATION RULES. TAKE A BOATING SAFETY COURSE TO IMPROVE YOUR KNOWLEDGE. ALWAYS OPERATE WITH COURTESY AND RESPECT.

ASPECTS OF ENVIRONMENTAL PROTECTION

To protect waterways from the spread of invasive species, always clean your boat after each use to remove unwanted hitchhikers such as Zebra Mussels and other aquatic pests.

In case of oil and fuel leakage, or in polluted or dirty waters, clean or recuperate the waste in a manner appropriate to the local environment. Excessive noise and exhaust emission should be avoided. Particular care should be used in the disposal of residues, e.g. of paint, paint removing substances or other cleansing agents.

LOADING

1. DO NOT EXCEED THE WEIGHT CARRYING CAPACITY INDICATED ON THE BOAT IDENTIFICATION PLATE.
2. Each person in the boat should wear a life jacket (personal flotation device).
3. Oars or paddles, and a repair kit should be carried on board for emergencies.
4. All loads placed in the boat should be distributed evenly for proper boat trim.

OPERATION: ROWING

1. Inflatable boats are equipped with oars and thole-pins; certain models also come with a rowing-seat as standard. Ensure seat is properly installed.
2. Install oars in thole-pins, attach thole-pin cap screws.

NOTE : DO NOT use oars as levers: they could break!

3. Local water conditions must be taken into account before operating the boat with oars or a small outboard motor. Boat power may not be strong enough to overcome currents in tidal inlets, small channels or shallows of shoal water regions.

OPERATION: OUTBOARD MOTOR WARNING!

- DO NOT OVERPOWER AND EXCEED THE MAXIMUM WEIGHT OF THE MOTOR! Overpowering can result in severe handling and/or stability problems with serious consequences or loss of motor.
1. Loose motor mounting screws will cause erratic boat operation and possibly the loss of your outboard motor!
 2. Read the manual carefully before assembling or operating the boat.

TOWING - ANCHORING - MOORING

1. The inflatable boat **MUST BE EMPTY** when it is towed by another boat. The towing line should be secured to the "D"- rings on each side of the inflatable boat. The boat must be under constant supervision when it is being towed.
2. Anchoring and mooring lines should be secured to the bow "D-ring".

Warning: For towing use only the Towing Bridle. Never tow your tender by the bow ring. The bow ring should only be used to attach a mooring line.

WATER HAZARDS

1. Wrecks, reefs, rocky shores, sandbanks, and shallows should be avoided or approached with caution.
2. When boating in unfamiliar waters, obtain information on local water hazards before setting out.

BEACHING

1. It is recommended not to use an engine when beaching. Do not drag the boat across rocks, sand, gravel or on a pavement as damage to the boat skin may result.
2. If the boat is to be temporarily left on a beach, part of the boat should be left in the water so that the internal heat caused by exposure to sunlight can escape and so that air pressure in the tubes can decrease.
3. Cover the boat to block direct exposure to sunlight if the boat is to be removed from the water for an extended period of time.

STORAGE

1. After use, the boat and all components should be washed with a mild soap and rinsed with fresh water. Dry all parts before storing in the carrying bag. This will help prevent mold or mildew.
2. Wooden parts should be inspected for damage or deterioration. Surface scratches or abrasions should be covered with a marine grade varnish.
3. To keep the boat looking new, store the boat in a cool and dry place and avoid excessive exposure to direct sunlight. UV exposure will degrade PVC and can result in adhesive failure.

IMPORANT: Waxes or cleaners

containing alcohol SHOULD NOT be used on the boat fabric. Alcohol will prematurely dry out the boat fabric. PVC has a low resistance to chemicals. Use MEK and other harsh cleaners lightly.

4. To avoid damaging the boat during storage, do not place heavy objects on it.
5. Store off the ground. Rodents may find their way into your boat, creating nests and chewing through the PVC materials.
6. High humidity may affect the adhesive on the boat. It is best to store your boat in a climate controlled area.

USE IN HIGH ALTITUDES

1. Normal full inflation pressure is 3.6 PSI for the tubes and 4.5 PSI for the keel and 8.0 PSI for the drop stitch inflatable floor. If the boat is inflated when at sea level (low altitude) and is brought to a high altitude (i.e. for use in a mountain lake), the air pressure must be reduced at the higher altitude to prevent over inflation.

7. REPAIR PROCEDURE

SMALL TEARS, CUTS, AND PUNCTURES

1. The repair of a small leak or puncture less than ½ inch (12.7mm) can be done with a round patch, 3 inches (76.2mm) diameter, minimum.
2. Both patches and surface on the boat must be dry and free of dirt and grease.
3. Apply 3 thin, even coats of adhesive to the surface of the boat and the patch. Wait 5 minutes between each coat. After the 3rd coat, wait 10-15 minutes before placing the patch on the boat skin.
4. Wait for at least 24 hours before re-inflating the boat.

LARGE REPAIRS OF SKIN, SEAMS, BULKHEADS, AND TRANSOM

For all repairs it is recommended to visit the video library at www.newportvessels.com/video-library/ for instruction.

EC DECLARATION OF CONFORMITY

According to EC Directive "Recreational Craft" 94/25/EC, Boat XV

We hereby declare that the boat described below, at the time it is placed on the market, meets, in its design, type and construction, the basic safety requirements of the; EC Directive for Recreational Craft

In the event of alterations, modifications made to the boat which have not been agreed by us and which affect the "basic safety requirements", this declaration no longer applies to that boat and is therefore null and void.

Designation of the boat: Inflatable Boat

Boat Type: The Seascope and The Santa Cruz.

Main Dimensions: (9' x 5') and (10' x 5')

Design Category: C (designed for voyages in coastal waters, large bays, estuaries, lakes and rivers where conditions up to, and including, wind force and significant wave heights up to, and including 2m may be experienced.)

Certification Module: AA

Application Directive: EC-Dir. (94/25/EC) Recreational Craft

The product described above meets the essential requirements of Directive 94/25/EC Annex 1, points 3.2 and 3.3

Certificate of Conformity No.: 88.01.0618, 88.01.0626, 88.01.0629, 88.01.0630, 88.01.0632, 88.01.0633, 88.01.0635, 88.01.0635, 88.01.0636, 88.01.0638, 88.01.0639, 88.01.0640, 88.01.0641, 88.01.0645, 88.01.0646

8. WARRANTY

View www.newportvessels.com/warranty-info/ for all warranty information.

WARRANTY CLAIM

5 steps to Complete Warranty Claim:

1. Visit: www.newportvessels.com
2. Click "Warranty Claim" at the bottom footer
3. Fill in all information and click "Submit":

When boating: learn and respect local regulations and practices. Do not neglect the safety rules, this could jeopardize your life and the lives of others.

9. GLOSSARY OF TERMS

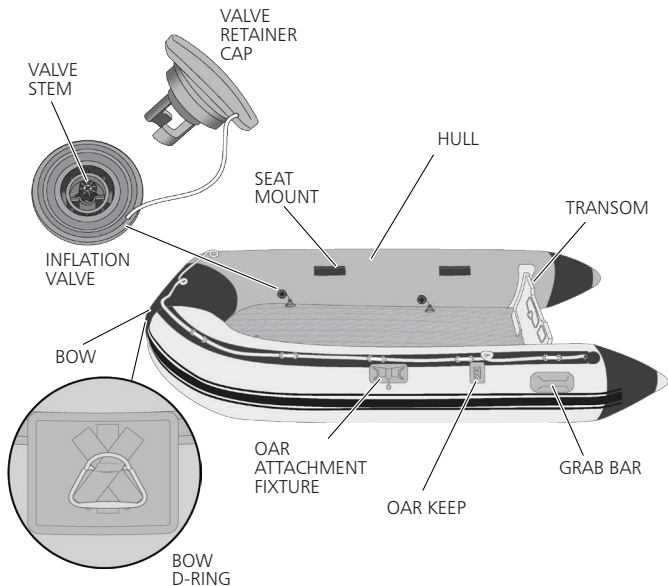

NOTE: The one-way valve makes inflation easy. The inner valve design allows air to flow into the hull but not out. Make sure the plastic valve stem is in the lock position for inflation, by pushing it in and turning clockwise. To unlock the valve and release air, push in and turn counter-clockwise.

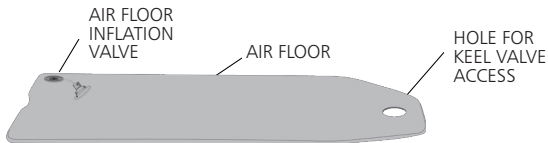

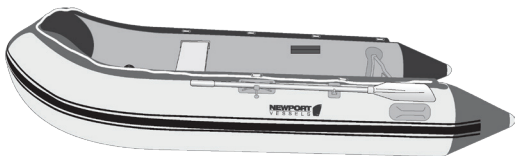

NEWPORT
VESSELS 

The logo for Newport Vessels. The word "NEWPORT" is in a bold, blue, sans-serif font. Below it, the word "VESSELS" is in a lighter blue, spaced-out, sans-serif font. To the right of the text is a blue graphic element consisting of a stylized wave or sail shape.

sales@newportvessels.com

Toll-free: (866) 721-0002

8:30 am - 4:30 pm PT