

STÛV 21

INSTALLATION MANUAL

Keep these instructions for future reference



Important: UNLOCK the door and remove all items before installing

These products are tested in accordance with AS/NZS 2918:2001. All installations must be carried out by an S.F.A.I.T (Solid Fuel Authorised Technician). In New Zealand, the Stuv 21 must be bolted to the base to comply with the seismic restraint provisions of AS/NZ 2918:2001

REQUIRED TOOLS



Grinder



Hammer



Crowbar



Knife with retractable blade



Measuring tape



Cutting pliers



Level



Impact driver



Flat screwdriver

REQUIRED HARDWARE



5 mm hex socket

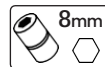

8 mm hex socket



10 mm hex socket



No. 2 square bit



No. 2 phillips bit

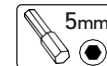

5 mm hex bit



Torx 20 bit



Torx 25 bit



Torx 30 bit

REQUIRED MATERIAL



12mm or 18mm non combustible board e.g Promatect H

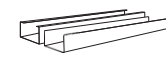

Metal framing

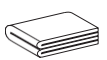

Protective fabric or cardboard



Floor and wall finishing

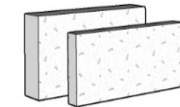

75mm Hebel or 40mm Skamotec



Construction wood



Stuv handle

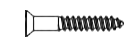

No. 8 Wood screws



Flue kit



You have chosen a Stûv fireplace : we thank you for it! It has been designed to offer maximum pleasure, comfort and safety. The utmost care has been taken in manufacturing it.

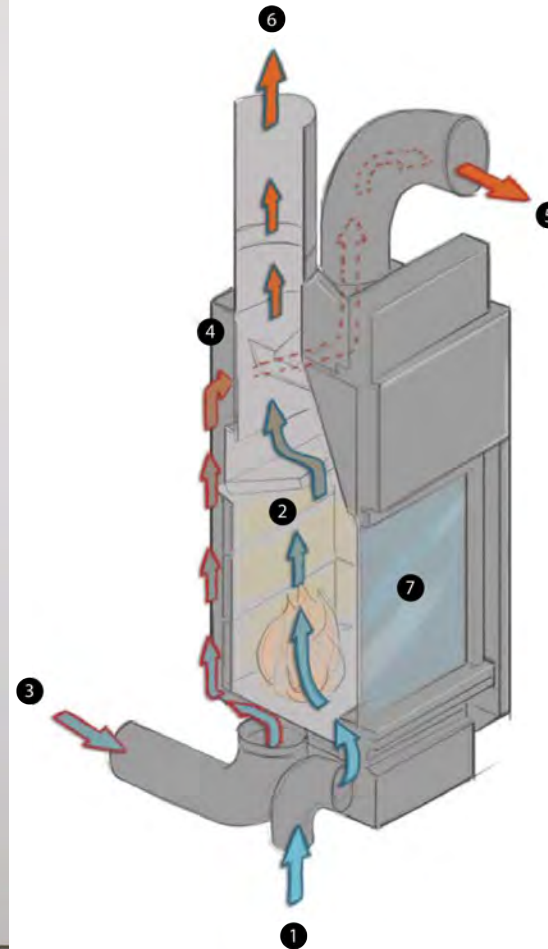

1. Combustion air.

Illustration with direct air intake under the stove. The outside air intake can also be located at the rear of the stove.

2. Combustion.

The air intake, the combustion chamber and smoke exhaust form an airtight system.

3. The air is taken into the room then heated by the stove.

4. The hot air is exchanged with the convection air which flows along the combustion chamber.

5. Heated air is spread throughout the room thanks to natural convection.

6. Burnt gases are released via the flue. Illustration with vertical discharge.

7. The window cleaning system involves an air supply that takes flue gasses away from the glass. This means that you can have flickering flames at all times.



IMPORTANT

Before installing this Stûv unit, inquire with your dealer about all the requirements that need to be met.

TABLE OF CONTENTS

1. CERTIFICATION



4

- 1. Safety Instructions 5
- 2. Marking labels 6

2. COMPONENTS



7

- 1. List of components 8
- 2. Optional Kits 11

3. DIMENSIONS



12

- 1. Single face 13
- 2. Double face 14
- 3. Cavity Ventilation 15
- 4. Floor protection 16
- 5. Framework characteristics 17
- 6. Non-combustible material cut-out plan 17
- 7. Hebel plan 18
- 8. Air Supply 21
- 9. Fitted television 23
- 10. Shelf made of combustible material 23
- 11. Hearth extension 24
- 12. Risk area 25

4. INSTALLATION



26

- 1. Unpacking 27
- 2. Option: Adjustable stands 30
- 3. Option: Airtight box 32
- 4. Door and pulleys 34
- 5. Preparing for convection 35
- 6. Leveling the unit 39
- 7. Interior of combustion chamber 40
- 8. Convection installation 44
- 9. Finishing without a front panel 46

5. CHIMNEY



47

- 1. Dimensions and certification 48
- 2. Typical installation 49
- 3. Flue termination 50

6. USE



51

- 1. Wood selection 52
- 2. Do not use 53
- 3. Firescreen 54
- 4. Starting the fire 55
- 5. Reloading the fire 56
- 6. Ash Removal 57

7. MAINTENANCE



56

- 1. Regular maintenance 57
- 2. Annual maintenance 58
- 3. Creosote and chimney-sweeping 59
- 4. Pulleys and counterweights 60
- 5. Components replacement 61

8. WARRANTY



65

- 1. Warranty details 66
- 2. Warranty form 67

1

CERTIFICATION

1.	SAFETY INSTRUCTIONS	5
2.	TECHNICAL SPECIFICATIONS	6
3.	MARKING LABELS	7



Tested by Australian Solid Fuel Testing Test Report No - ASFT18044

The Stûv 21 Inbuilt appliance installed with a triple skin flue system, conforms to the requirements of Australian/New Zealand Standard 2918:2001, with respect to floor, side wall and rear wall surface temperatures, when tested in accordance with Appendix B of AS/NZS2918:2001.

This wood heater must be installed in accordance with standard AS/NZS 2918:2001, the Installation Code for Solid-Fuel-Burning Appliances and Equipment, the applicable building code and standards applicable to the structure in which the insert will be installed.

The instructions for the installation of this wood heater comply with the above-mentioned standards. They must be closely followed to eliminate the risk of serious problems.

This Stûv unit must be installed by a qualified professional. Improper installation could result in a fire.

To reduce the risk of fire, read this manual carefully before installing or using the wood heater. If the installation instructions are not followed and the wood heater is improperly installed, the risk of incident increases. This can result in fire, property damage, bodily injury and even death.

Keep these instructions for future reference.

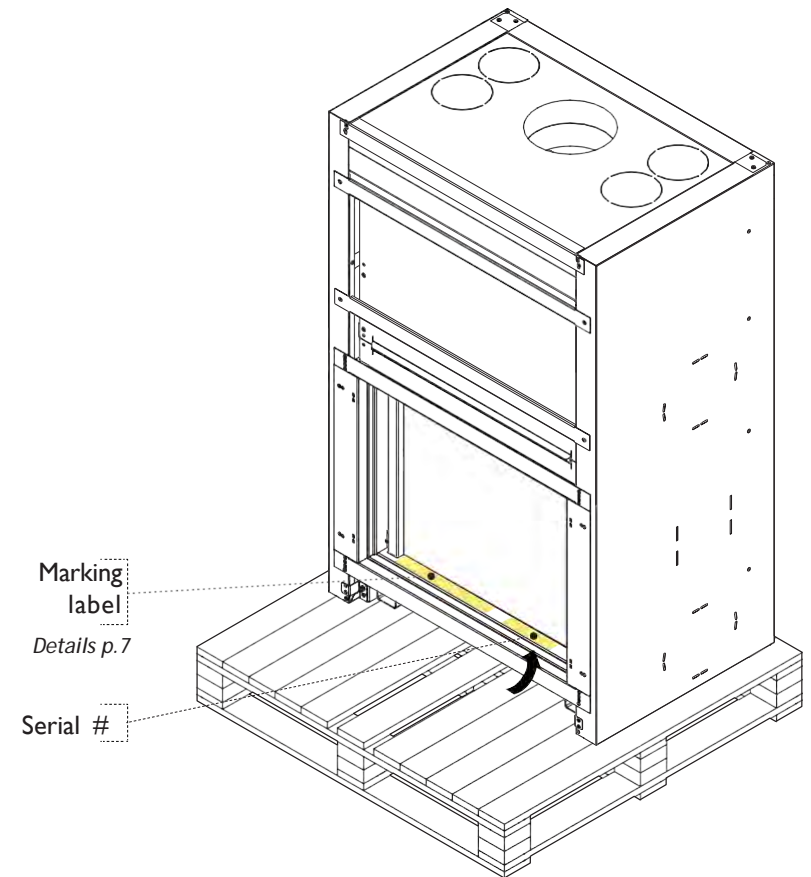

NOTE

We strongly recommend that our products be installed and maintained by professionals certified by the NZHHA (New Zealand Home Heating Association)

The marking label is located on the cap shown above. The product serial number can be found on the riveted label above the hearth. You will find all the information you need to register your product.



CAUTION

- It is essential that the installation of this Stûv be carried out by a qualified professional.
- The instructions for the installation of this unit comply with the abovementioned standards. They must be closely followed to eliminate the risk of serious problems. Any use contrary to the user manual is a violation of federal law.
- Improper installation of this Stûv unit could result in a fire. To reduce the risk of fire, follow the installation instructions to the letter. Failure to follow the instructions in this manual may result in property damage, bodily injury or death.
- This unit requires periodic inspection and maintenance for proper operation (minimum three times during the heating season).
- Any modifications made to this unit may pose a hazard and will void the warranty. Should repairs be necessary, use only Stûv replacement parts.
- Combustible materials such as firewood, wet clothing, etc. placed too close to the unit could catch fire.
- We recommend storing solid fuels in a clean, dry environment. Do not place this type of fuel within the risk area or in the loading/ash removal area.
- Never leave the fireplace unattended when the door is open.
- Always close the door after the ignition period.
- Do not burn garbage, plastic, petroleum-based materials, gasoline, rubber, industrial solvents, flammable liquids such as naphtha and motor oil, paper, cardboard, wood extracted from salt water and dried, painted wood or any substance that emit dense fumes and strong odours.
- Make sure the home is equipped with a smoke and carbon monoxide detector.
- Do not connect this appliance to a chimney flue serving another appliance.
- This unit is hot when in use. Keep children, clothing and furniture at a safe distance. Touching the appliance while it is in operation may cause burns.
- Some parts of the fireplace can be very hot when operated at rated capacity.
- Do not allow the fireplace to heat to the point where parts become red.
- Do not use a grate or other methods to elevate the fuel. Burn firewood directly on the firebricks.
- Do not overheat the unit. Attempting to exceed the single burn rate of this unit may permanently damage it.
- Conduct regular maintenance of the fireplace as previously recommended.
- Never use chemicals or other liquids such as gasoline, gasoline-based lantern fuel, kerosene, charcoal liquid, or similar liquids to start or feed a fire in the fireplace. Keep all such liquids away from the unit while it is in operation.
- Do not install this unit in a mobile home.
- The air inlets and outlets must remain free of obstacles at all times.
- The installation of the unit must comply with all local and national regulations.
- Inspect and sweep the chimney frequently. In certain operating conditions, creosote can build up quickly. Inspect and repair the insert to ensure proper operation.
- Objects placed in front of the unit must be kept at a distance of at least 1200mm from the unit's glass face.

1 .2 TECHNICAL SPECIFICATIONS

SINGLE FACE	21-95 SF	21-105 SF	21-125 SF	21-135 SF
Maximum power	15kW*	19kW*	21kW*	20kW*
Performance	76%	84%	76%	76%
Max log length	700mm	800mm	1000mm	1000mm
Weight	292kg	224kg	305kg	286kg
Fuel	SOFTWOOD			

DOUBLE FACE	21-95 DF	21-125 DF
Maximum power	22kW	27kW
Performance	76%	72%
Max log length	700mm	1000mm
Weight	310kg	310kg
Fuel	SOFTWOOD	

* These nominal heat outputs were obtained according to a European testing protocol.

2

COMPONENTS

1.	LIST OF COMPONENTS	9
2.	CONVECTION KIT	12
3.	OPTIONAL KITS	13



2.1 LIST OF COMPONENTS



SINGLE FACE (SF)

DOUBLE FACE (DF)

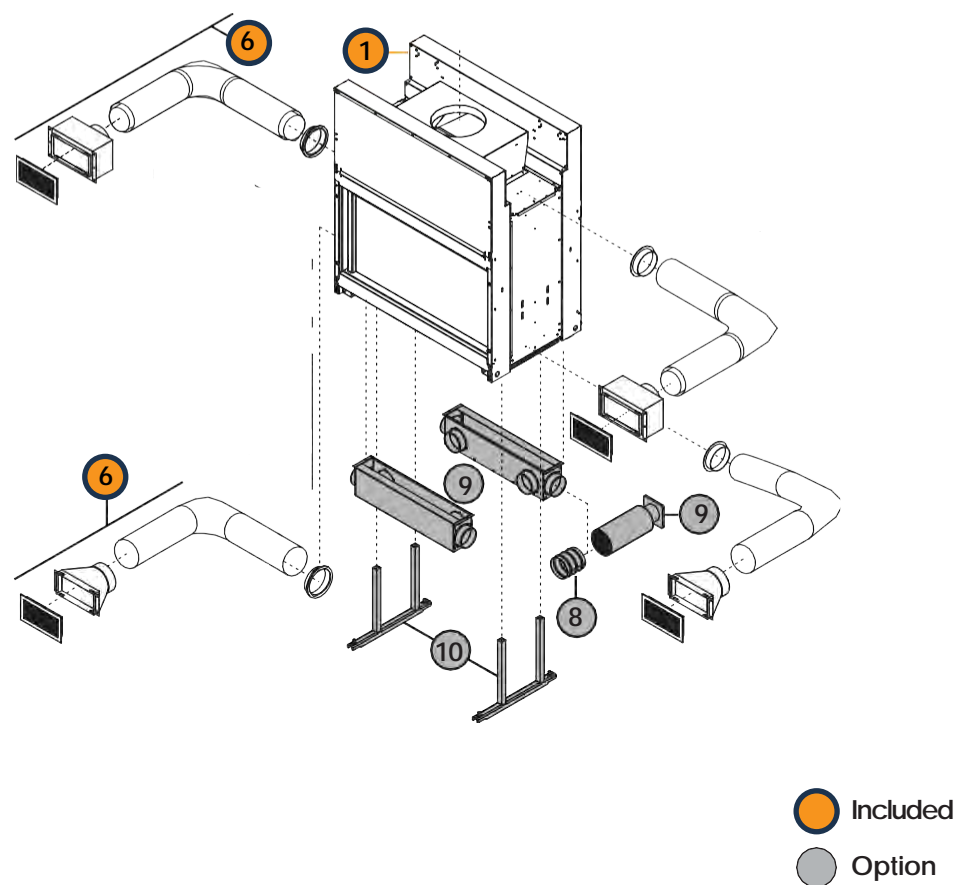
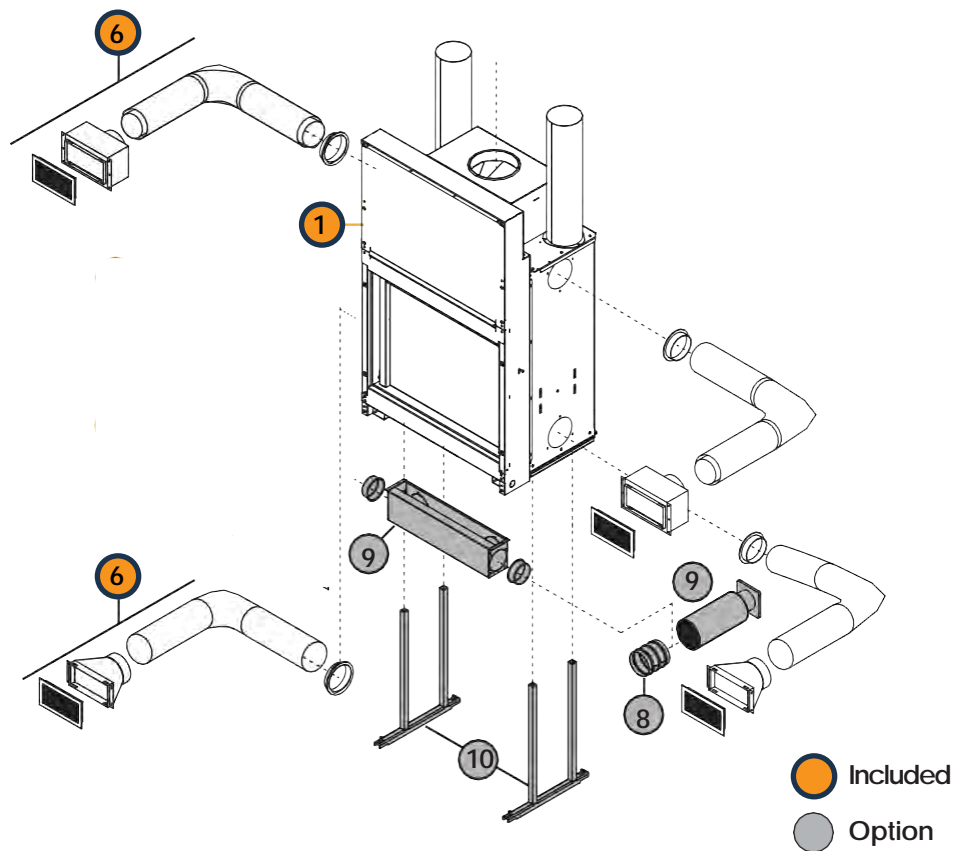

2.1 LIST OF COMPONENTS



21-95 SF

#	DESCRIPTION	PRODUCT CODE	INCLUDED OR OPTION	Q ^{TY}
1	Fireplace	10021007	Included	1
2	Extend Gather – 250mm	12015057	Included	1
3	Hebel*		Included	11
4	Raised Door Kit	13007008	Included	1
5	Frame (Thin)	13004110	Included	1
6	Internal cold & hot air ducting kit	12002000	Included	1
7	Internal vent Cover 200 x200mm	12001005	Included	4
8	Air damper 150mm	120020022	Option	1
9	Outside airtight box & ducting kit	1200203600	Option	1
10	Adjustable stand	1300200000	Option	1

21-105 SF

#	DESCRIPTION	PRODUCT CODE	INCLUDED OR OPTION	Q ^{TY}
1	Fireplace	10021009	Included	1
2	Extended Gather -200mm	120115037	Included	1
3	Hebel*		Included	11
4	Raised Door Kit	N/A		
5	Frame (Thin)	13004111	Included	1
6	Internal cold & hot air ducting Kit	12002000	Included	1
7	Internal vent Cover 200 x200mm	12001005	Included	4
8	Air damper 150mm	12002022	Option	1
9	Outside airtight box & ducting kit	12002028	Option	1
10	Adjustable stand	1300200000	Option	1

21-125 SF

#	DESCRIPTION	PRODUCT CODE	INCLUDED OR OPTION	Q ^{TY}
1	Fireplace	10021010	Included	1
2	Extended Gather – 300mm	12015009	Included	1
3	Hebel*		Included	12
4	Raised Door Kit	13007002	Included	1
5	Frame (Thin)	13004112	Included	1
6	Internal cold & hot air ducting Kit	12002000	Included	1
7	Internal vent Cover 200 x200mm	12001005	Included	4
8	Air damper 150mm	12002022	Option	1
9	Outside airtight box & ducting kit	12002066	Option	1
10	Adjustable stand	13002000	Option	1

21-135 SF

#	DESCRIPTION	PRODUCT CODE	INCLUDED OR OPTION	Q ^{TY}
1	Fireplace	10021012	Included	1
2	Extended Gather – 250mm	12015011	Included	1
3	Hebel*		Included	12
4	Raised Door Kit	N/A		
5	Frame (Thin)	13004113	Included	1
6	Internal cold & hot air ducting Kit	12002000	Included	1
7	Internal vent Cover 200 x200mm	12001005	Included	4
8	Air damper 150mm	12002022	Option	1
9	Airtight box	N/A		
10	Adjustable stand	1300200000	Option	1



NOTE - * Not required for masonry installs

2.1 LIST OF COMPONENTS



21-95 DF

#	DESCRIPTION	PRODUCT CODE	INCLUDED OR OPTION	QTY
1	Fireplace	I0021008	Included	1
2	Extended Gather- 250mm	I2015057	Included	1
3	Hebel **		Included	10
4	Raised Door Kit *	I3007008	Included	2
5	Frame (Thin)**	I3004110	Included	2
6	Internal cold & hot air ducting kit**	I2002000	Included	1
7	Internal vent Cover 200 x200mm	I2001005	Included	4
8	Air damper 150mm	I20020022	Option	1
9	Outside airtight box & ducting kit	I2002036	Option	2
10	Adjustable stand **	I3002000	Option	1
11	Flat Gather for Steel Cladding *	I2016051	Option	1

21-125 DF

#	DESCRIPTION	PRODUCT CODE	INCLUDED OR OPTION	QTY
1	Fireplace	I0021011	Included	1
2	Extended Gather - 300mm	I2015009	Included	1
3	Hebel **		Included	10
4	Raised Door Kit*	I3007002	Included	2
5	Frame (Thin)**	I3004112	Included	2
6	Internal cold & hot air ducting kit**	I2002000	Included	1
7	Internal vent Cover 200 x200mm	I2001005	Included	4
8	Air damper 150mm	I2002022	Option	1
9	Outside airtight box & ducting kit	I2002066	Option	2
10	Adjustable stand**	I3002000	Option	1
11	Flat Gather for Steel Cladding *	I2016009	Option	1



NOTE - * Required for Stûv cladding installs
 ** Not required for Stûv cladding installs

2.3 OPTIONAL ACCESSORIES



ADJUSTABLE STAND - 13002000

To raise the unit

Follow the instructions supplied with the stand.

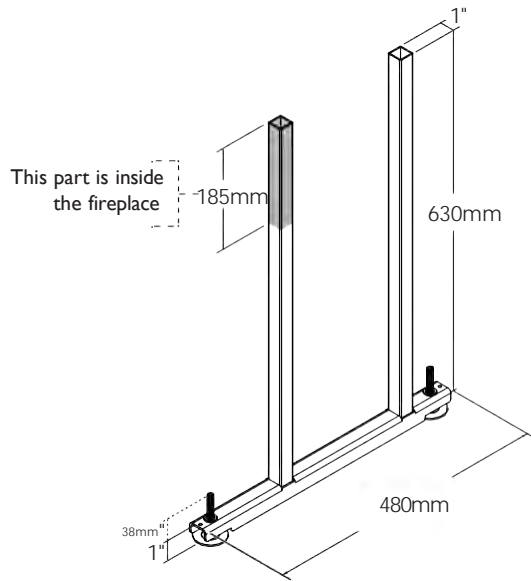

NOTE
Brackets are secured over the base of the stand for seismic restraint.

AIR DAMPER - 120020022

For outside air intake

Follow the instructions supplied with the air damper.

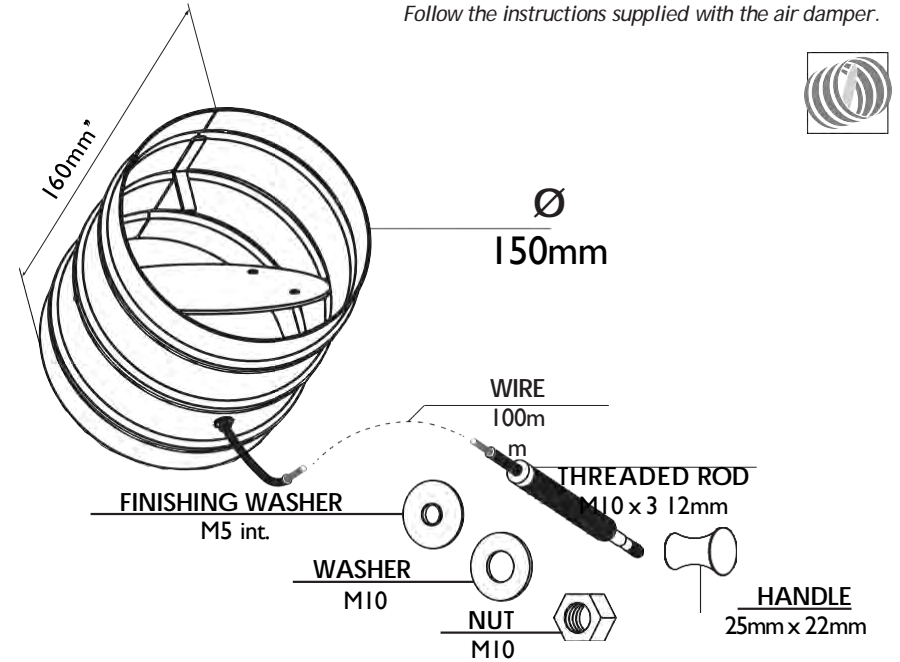

AIRTIGHT BOX & OUTSIDE AIR KIT

For outside air intake

NOTE
Ducting pipe & external vent comes with the kit

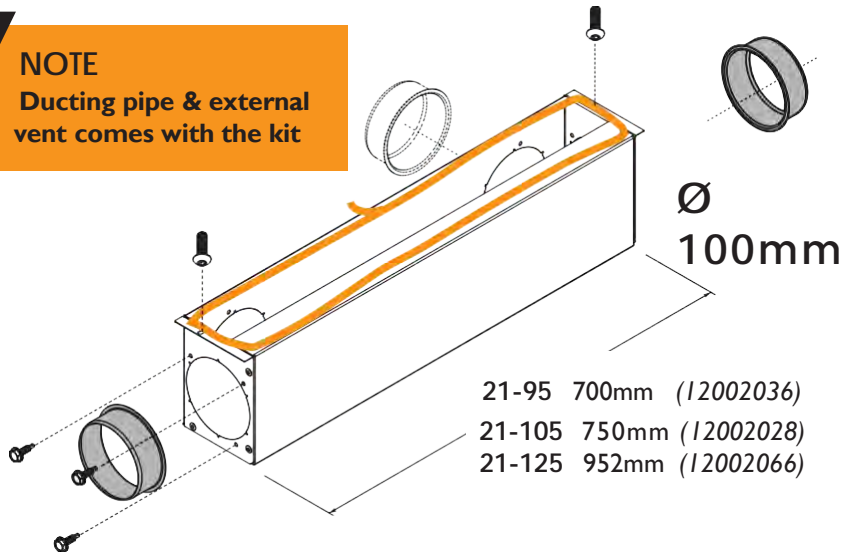

OUTSIDE AIR KIT WITHOUT AIRBOX

Follow the instructions supplied with the air damper.

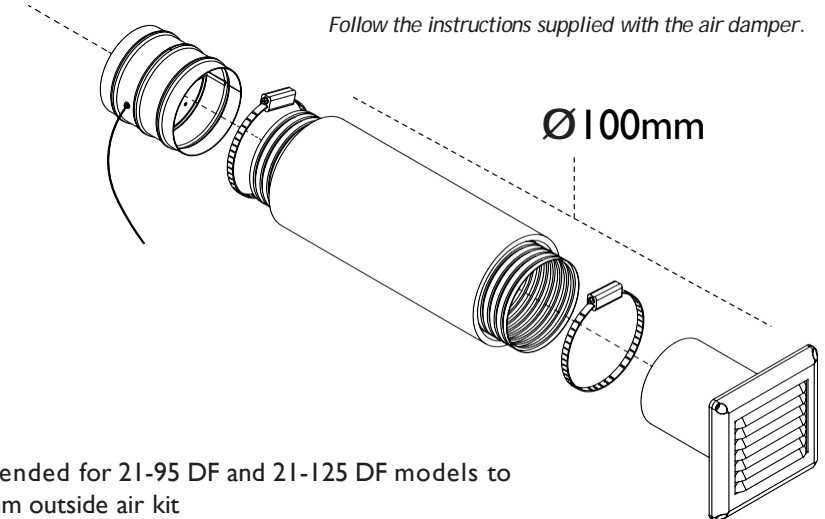

It is recommended for 21-95 DF and 21-125 DF models to use a $\varnothing 150\text{mm}$ outside air kit

3

DIMENSIONS

1.	SIMPLE FACE	12
2.	DOUBLE FACE	13
3.	CAVITY VENTILATION	14
4.	FLOOR PROTECTION	15
5.	FRAMEWORK CHARACTERISTICS	16
6.	NON-COMBUSTIBLE MATERIAL CUT-OUT PLAN	17
7.	AIR SUPPLY	20
8.	FITTED TELEVISION	22
9.	SHELF MADE OF COMBUSTIBLE MATERIAL	22
10.	HEARTH EXTENSION	23
11.	RISK AREA	24

3.1 SIMPLE FACE



FRONT VIEW

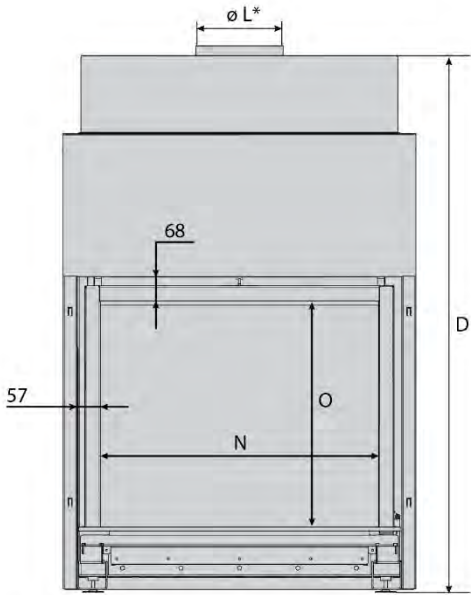

SIDE VIEW

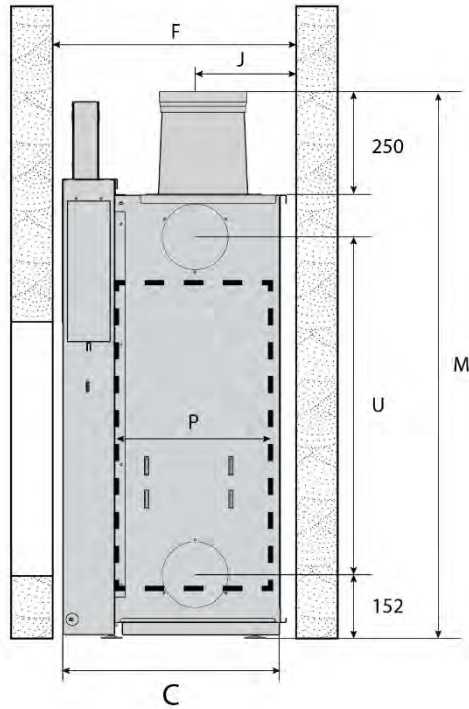

TOP VIEW

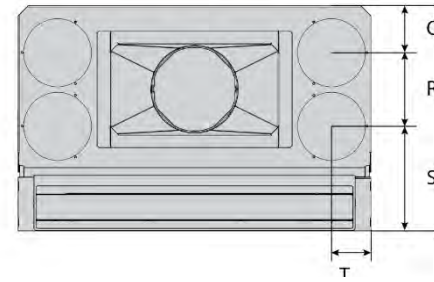

BASE VIEW

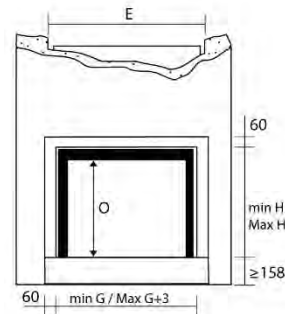
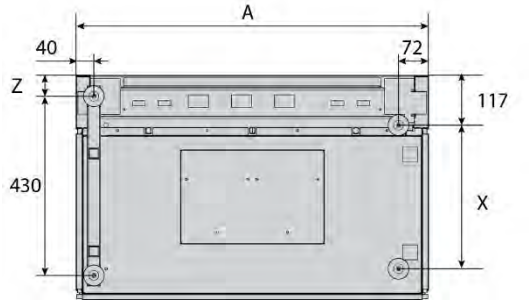

Finish with Stuv frame

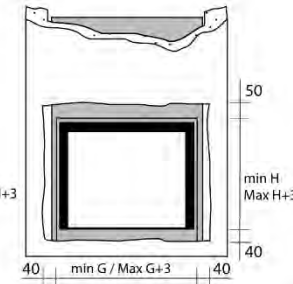

Opening to be left in the brickwork for a Stuv frame and counter-frame. The frame will conceal the imperfections of the opening.

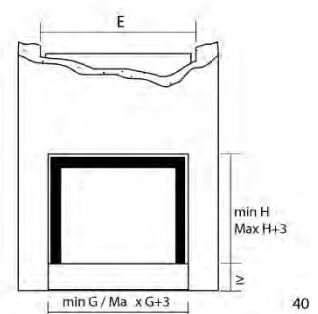

Opening to be left in the brickwork for a finish without a Stuv frame

FRONT VIEW	A	C	D	E	F*	G	H	J*	L	M	N	O	P	Q	R	S	T	U	V	W	X	Y	Z
21-95 SF	950	590	1455	960	610	884	683	221	250	1430	770	615	381	130	176	281	95	926	702	302	395	202	75
21-105 SF	1050	496	1040	1060	515	984	469	201	200	1245	870	400	288	83	171	242	125	742	750	352	300	165	35
21-125 SF	1250	563	1295	1260	585	1184	603	221	300	1320	1070	535	354	83	171	242	125	742	750	352	300	165	35
21-135 SF	1350	500	1040	1360	515	1282	469	203	250	1245	1170	400	291	83	171	242	125	742	750	352	300	165	35

* Masonry only

3.2 DOUBLE FACE



FRONT VIEW

SIDE VIEW

TOP VIEW

BOTTOM VIEW

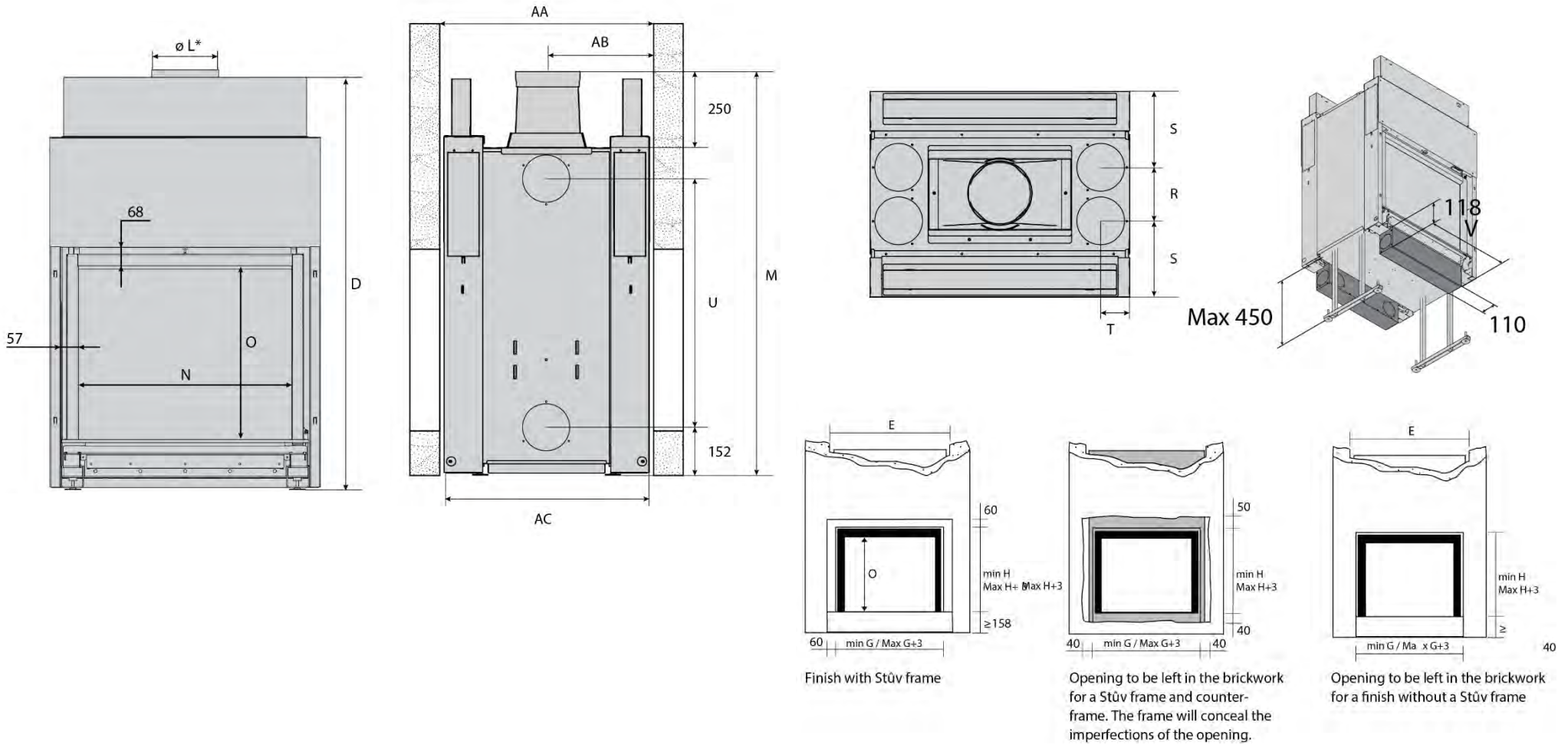

FRONT VIEW	AA*	AB*	AC	D	E	F	G	H	J	L	M	N	O	P	Q	R	S	T	U
21-95 DF	690	335	670	1445	960	610	884	683	201	250	1430	770	615	381	130	176	281	95	742
21-125 DF	690	335	670	1295	585	585	1184	603	221	300	1320	1070	535	354	83	171	242	125	742

* Masonry only

3.3 Cavity Venting (REQUIRED)



CAVITY VENTILATION OPTIONS

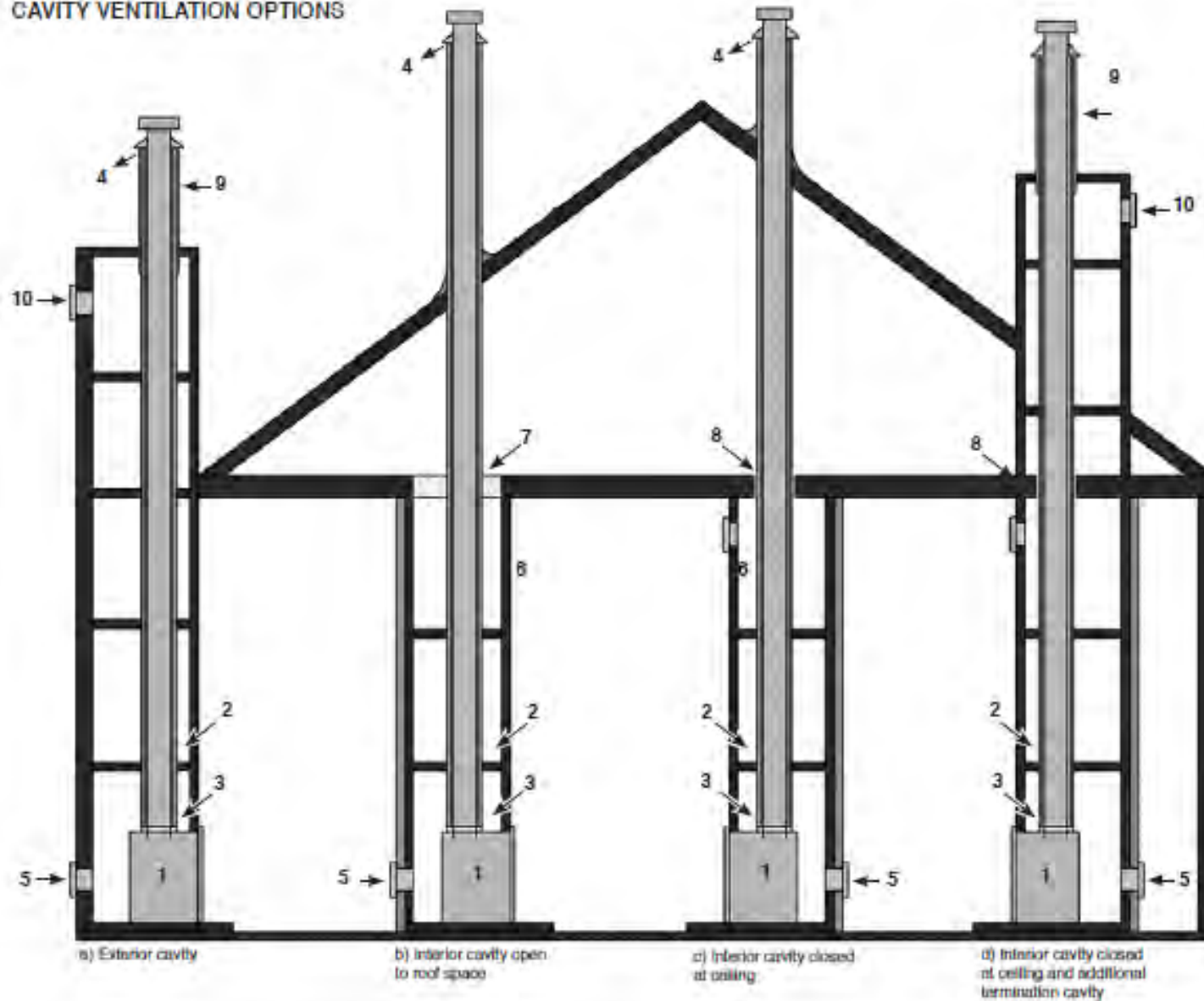

NOTE
 The cavity must be vented. 2 x 100mm dia. vents or equivalent. Refer to Section 5, pg. 46 for chimney details.

- LEGEND**
1. Appliance
 2. Vented flue system with 2 casings
 3. Flue system air inlet
 4. Flue system air outlet
 5. Bottom vent – cool air inlet
 6. Room vent – interior hot air outlet
 7. Ceiling vent – vermin proof mesh
 8. Vented ceiling penetration
 9. Venting through casing
 10. Top side vent to built-in structure

3.4 FLOOR PROTECTION (REQUIRED)



For the Stüv 21, all materials installed under and in front of the fireplace must be non-combustible to a height of 165mm see below for additional information.

- 1 Floor protection is **MANDATORY**. See adjoining section.
- 2 All components located in the hearth extension zone, for a height of 300mm from the bottom of the glass must be in **non-combustible materials**.
- 3 See section : **3.10 Hearth projection**
- 4 2x 12mm cement boards, 1 x 20mm or 75mm Hebel are **ALWAYS MANDATORY** under the fireplace (unless sitting directly onto concrete floor).
- 5 Appliance must sit a minimum of 150mm above the floor unless sitting directly onto concrete floor.

In order to be compliant with AS/NZS2918:2001 floor protection is mandatory. The surface of the floor in front of the unit must be protected by **non-combustible floor protection** (tile, plate, slab..) .

This protection must cover the width of the glass **plus 200mm** on each side of the glass.

A non-combustible sealing strip must be placed through the whole length of the junction between the cement board and the finished floor to avoid ember projections.

NOTE
If using optional steel stand, Hebel is not required. Stand either sits on concrete floor or non-combustible board.

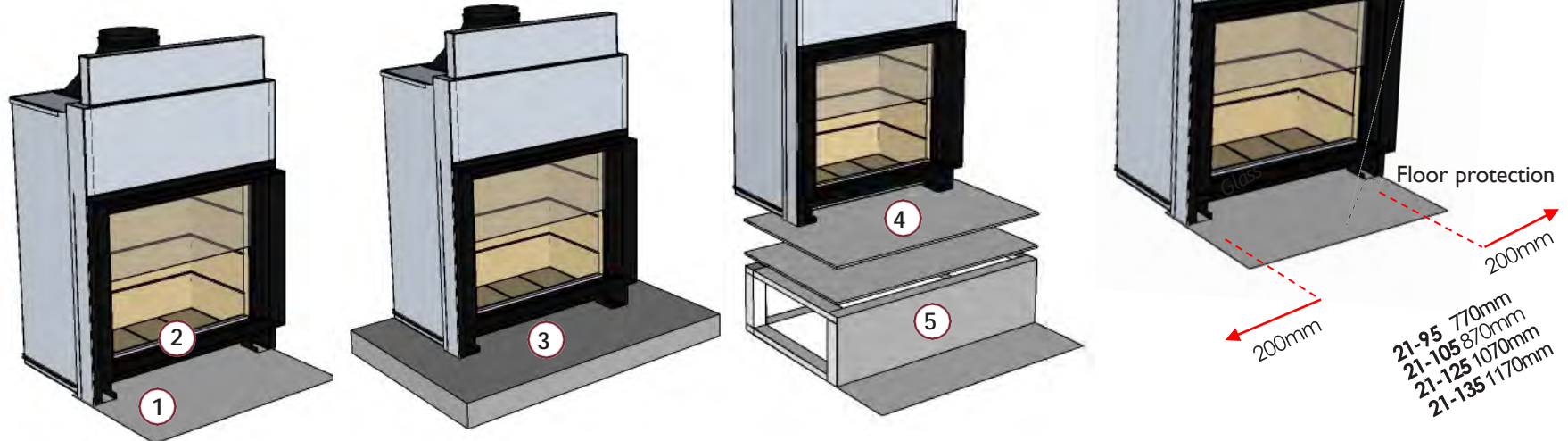

3.5 FRAMEWORK CHARACTERISTICS

3.6 NON-COMBUSTIBLE MATERIAL



NOTE

Framing is not always perfectly level. We suggest that at least 5mm clearance be added to the dimensions listed in the table.

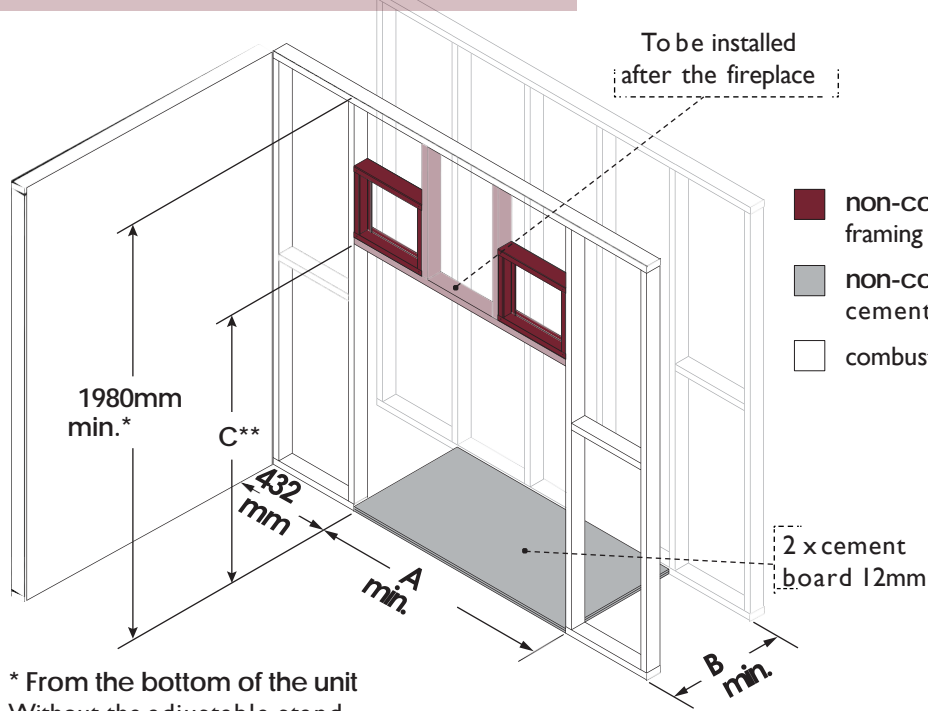

* From the bottom of the unit
Without the adjustable stand

MODEL	A (mm)	B (mm)	C**
21-95 SF	1300	865	1800
21-105 SF	1400	800	1600
21-125 SF	1600	850	1705
21-135 SF	1700	800	1600
21-95 DF	1300	870	1800
21-125 DF	1600	870	1705

Depth includes 100mm for trim frame finish at front (both sides for DF). B dimension for DF is outside to outside.



IMPORTANT

Use 75mm Hebel and a 12mm non-combustible board to finish the opening after the fireplace installation or other **non-combustible materials** may be used. The framing and the wall finishing around the hot air grille boxes are required to be in non-combustible materials. It is mandatory to affix 100mm of NCB around the hot air grille.

MODEL	D (mm)	E (mm)	F (mm)	G (mm)
21-95	1300	850	884	683
21-105	1400	850	984	469
21-125	1600	850	1184	603
21-135	1700	850	1282	469

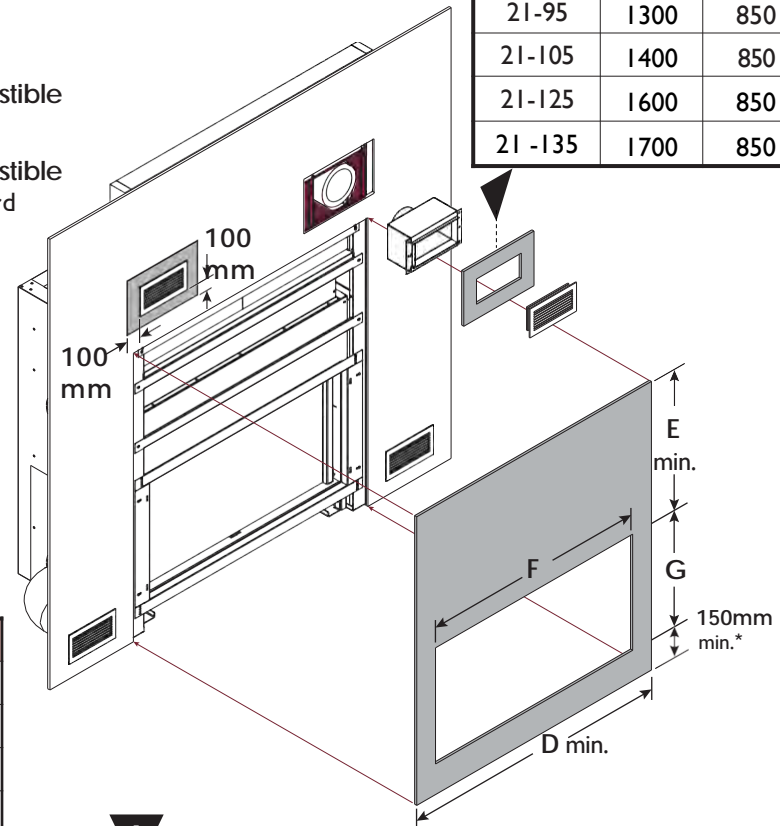

NOTE

Width and depth is based on 75mm Hebel with 100mm side and rear air gaps between appliance and Hebel. If using Skamotec reduce by 35mm. For masonry installations 50mm air gap is required, reduce depth by 125mm and width by 250mm.

3.5

Hebel Cell Dimensions



MODEL	No. of Hebel Panels	Base *	Sides	Rear	Top	Face
21-95 SF	12	1300 x 865	1650 x 865 RHS 1650 x 865 LHS	1650 x 1150	1300 x 865	800 x 1150
21 -105 SF	12	1400 x 800	1425 x 800 RHS 1425 x 800 LHS	1425 x 1250	1400 x 800	800 x 1250

NOTE
 No. of Skamotec panels is 50% less than Hebel
 *Hebel base not required if using the steel stand or the appliance is sitting on concrete.

21-95 SF

21 -105 SF

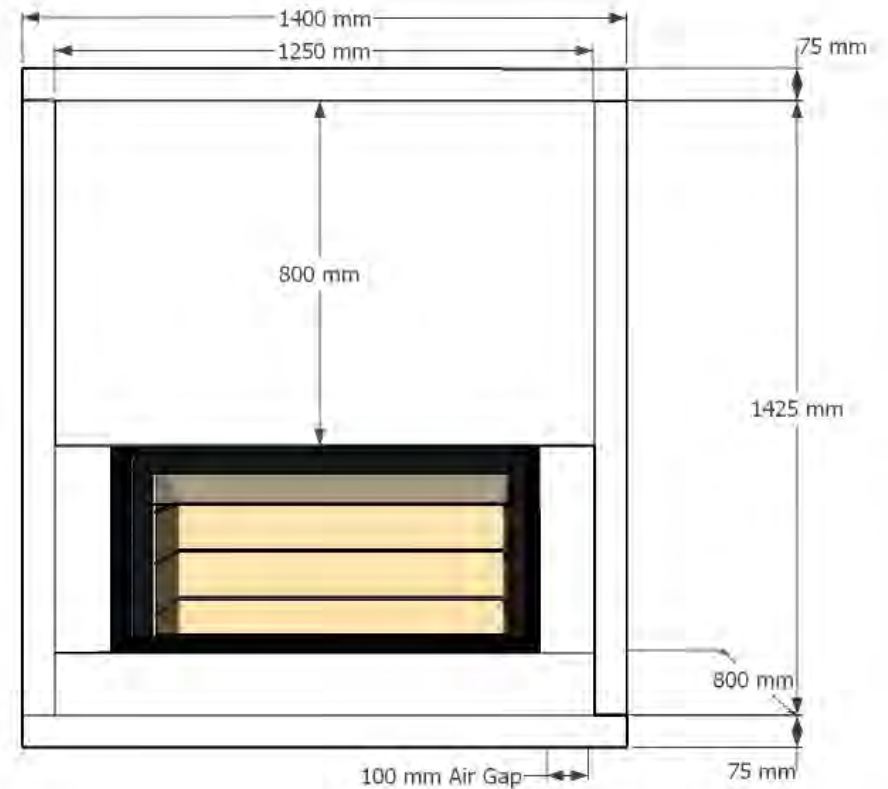
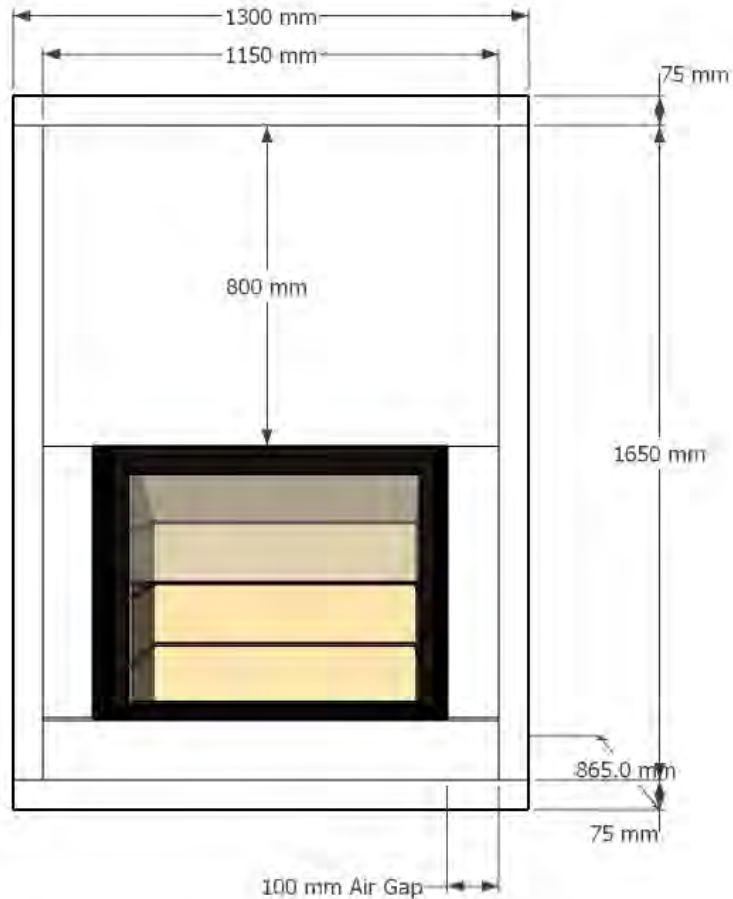

3.5

Hebel Cell Dimensions



MODEL	No. of Hebel Panels	Base*	Sides	Rear	Top	Face
21-125 SF	16	1600 x 850	1555 x 850 RHS 1555 x 850 LHS	1555 x 1450	1600 x 850	1450 x 800
21 -135 SF	16	1700 x 800	1430 x 800 RHS 1430 x 800 LHS	1430 x 1550	1700 x 800	1550 x 800

NOTE
 No. of Skamotec panels
 Is 50% less than Hebel

*Hebel base not required if
 using the steel stand or the
 appliance is sitting on
 concrete.

21-125 SF

21 -135 SF

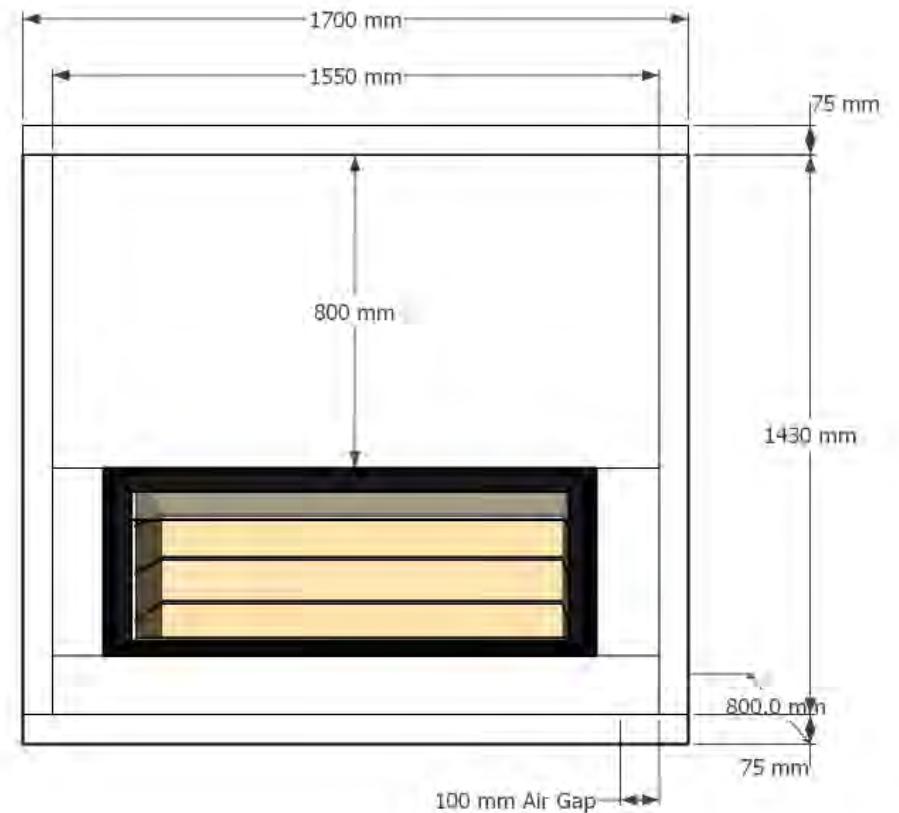
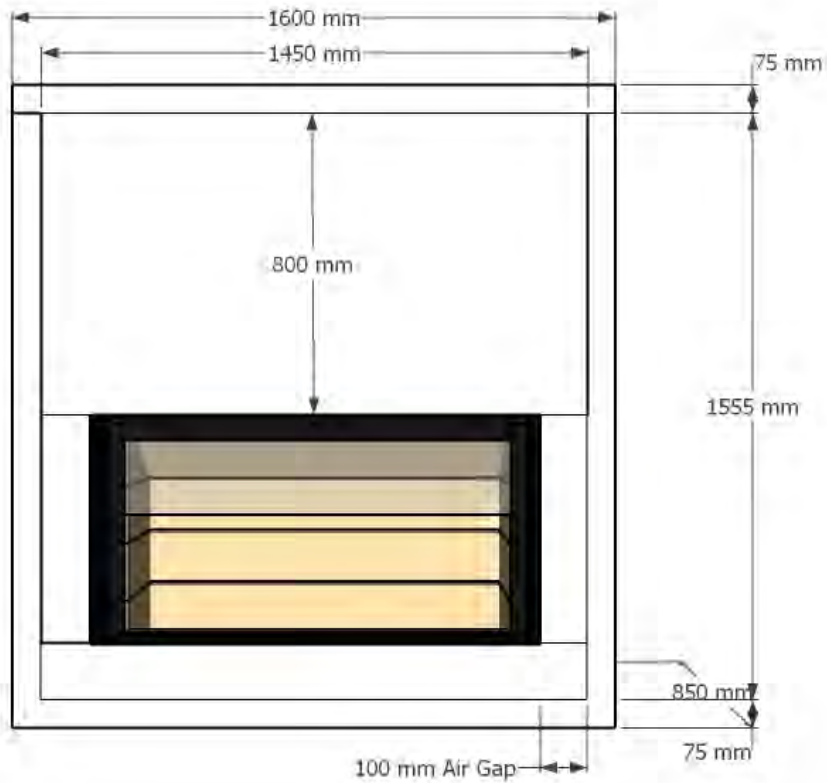

3.5

Hebel Cell Dimensions



MODEL	No. of Hebel Panels	Base	Side	Rear	Top	Face
21-95 DF	10	1300 x 870	1650 x 870 RHS 1650 x 870 LHS	1650 x 1150	1300 x 870	800 x 1150
21-125 SF	12	1600 x 870	1555 x 870 RHS 1555 x 870 LHS	1555 x 1450	1600 x 870	1450 x 800

NOTE
 No. of Skamotec panels is 50% less than Hebel
 *Hebel base not required if using the steel stand or the appliance is sitting on concrete.

21-95 DF

21 -125 DF

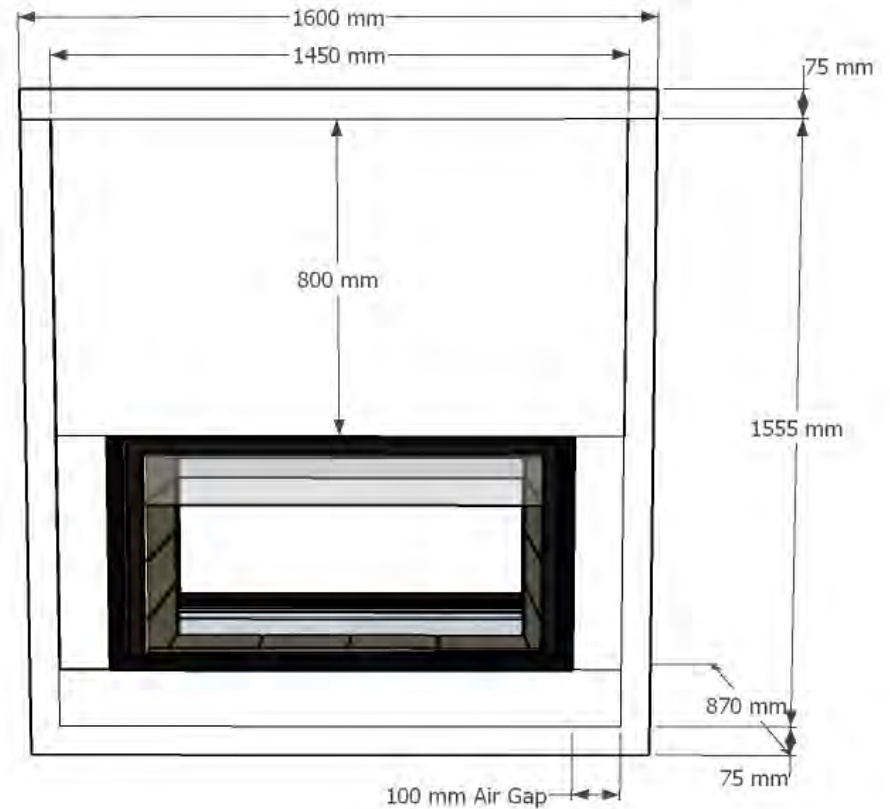
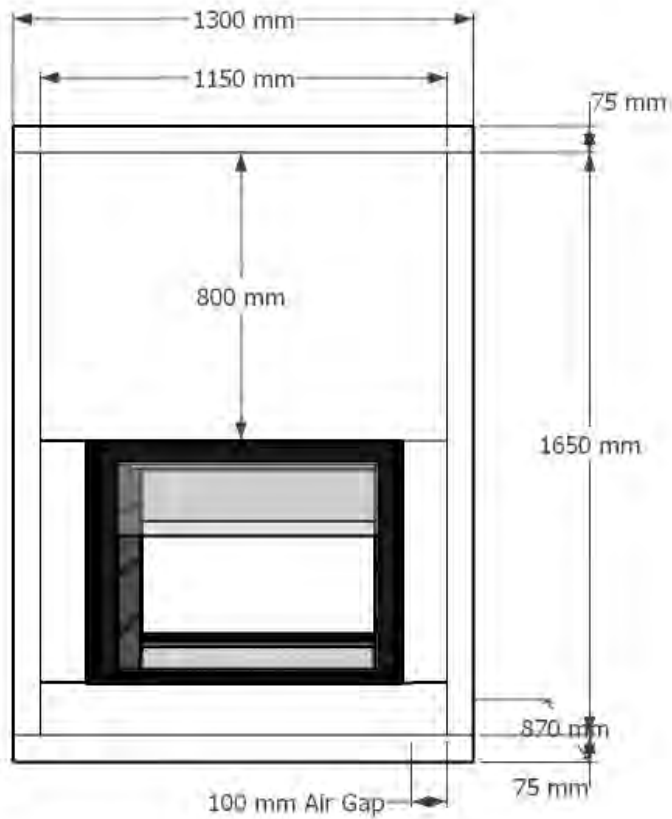

3.6 AIR SUPPLY



Poor airflow in your convection system should be avoided. Installing the hot air outlet in an enclosed or restricted space, such as a cabinet box or shelf, is prohibited.

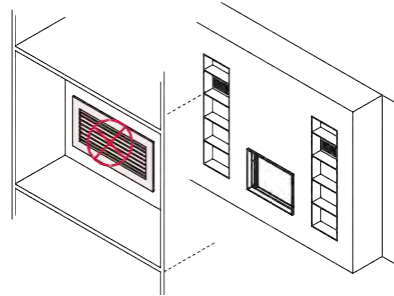

It is important that the airflow be continuous. It is forbidden to take fresh air from a closed room and to discharge the same airflow into another closed room.

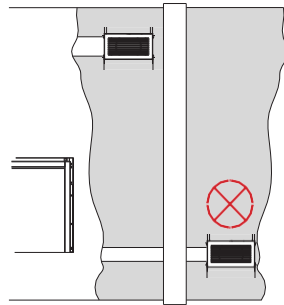

The hot air duct must always be installed horizontally or ascending as hot air naturally goes up, never down.

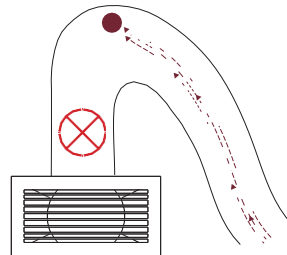

It is forbidden to have a curtain or any other object that can block the airflow located less than 610mm in front of the hot air outlet, as air could get trapped behind it creating a heat trap.

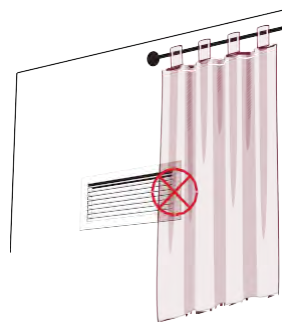

It is essential to install two room air intakes and two hot air outlets in order to have a natural, functional and efficient convection.

- Hot air outlets
- Room air intakes

To ensure adequate convection, air inlet and outlet should be facing the same direction in the same room.

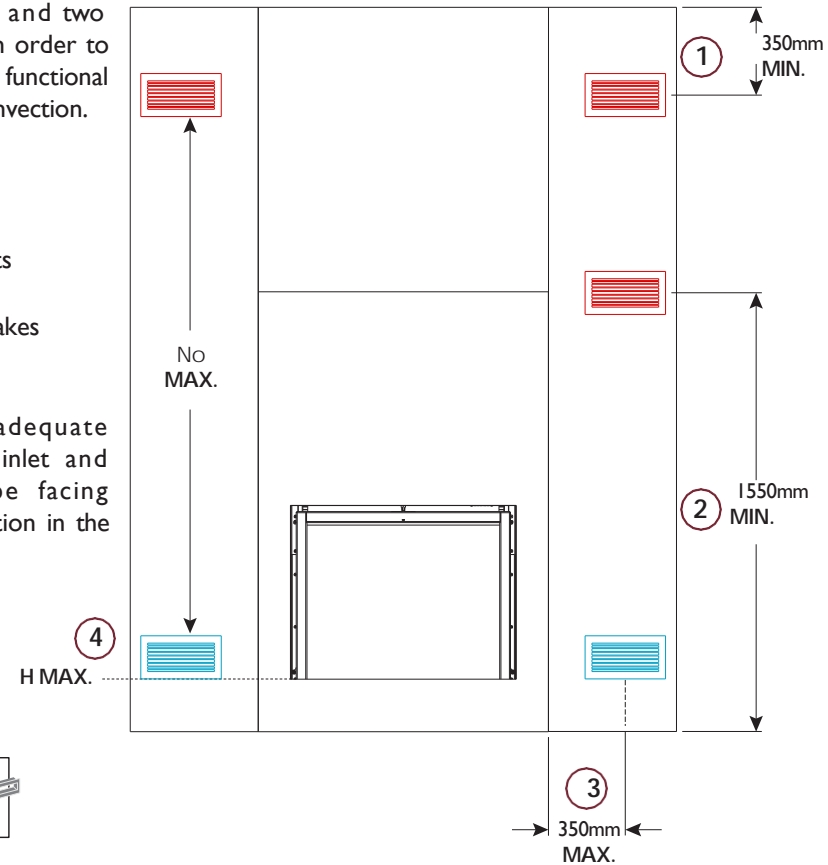

- ① 350mm Minimum distance from the ceiling to the centre of the hot air outlet.
- ② 1550mm Minimum distance from the floor to the centre of the hot air outlet.
- ③ 350mm Maximum horizontal distance from the side of the fireplace in the centre of the air grilles.
- ④ The room air inlet for convection cannot be higher than the bottom of the glass.

3.6 AIR SUPPLY



The fireplace is supplied with two types of air: convection air and combustion air.

CONVECTION AIR

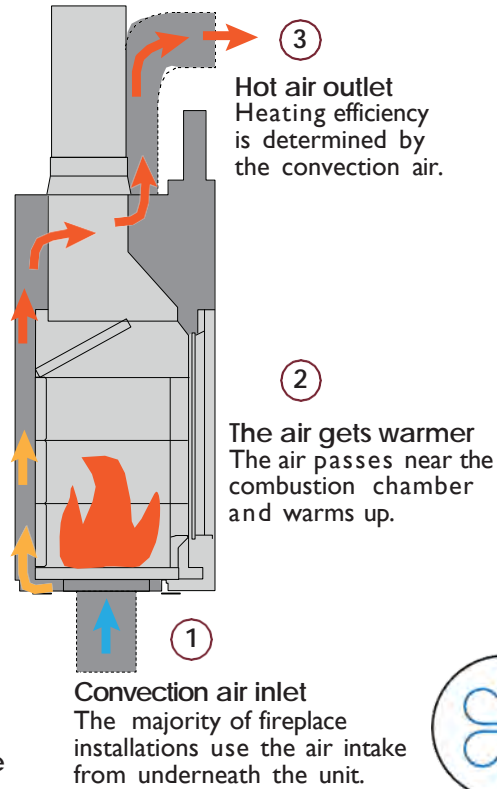

COMBUSTION AIR

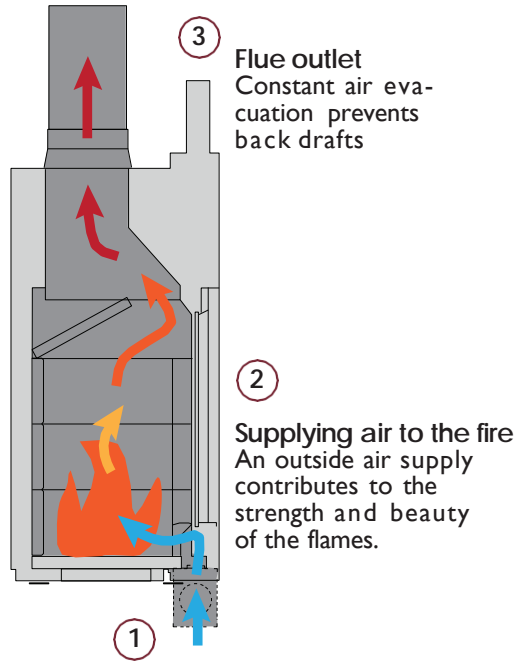

Combustion air intake
Outside air via the airtight box is recommended for a better draft.

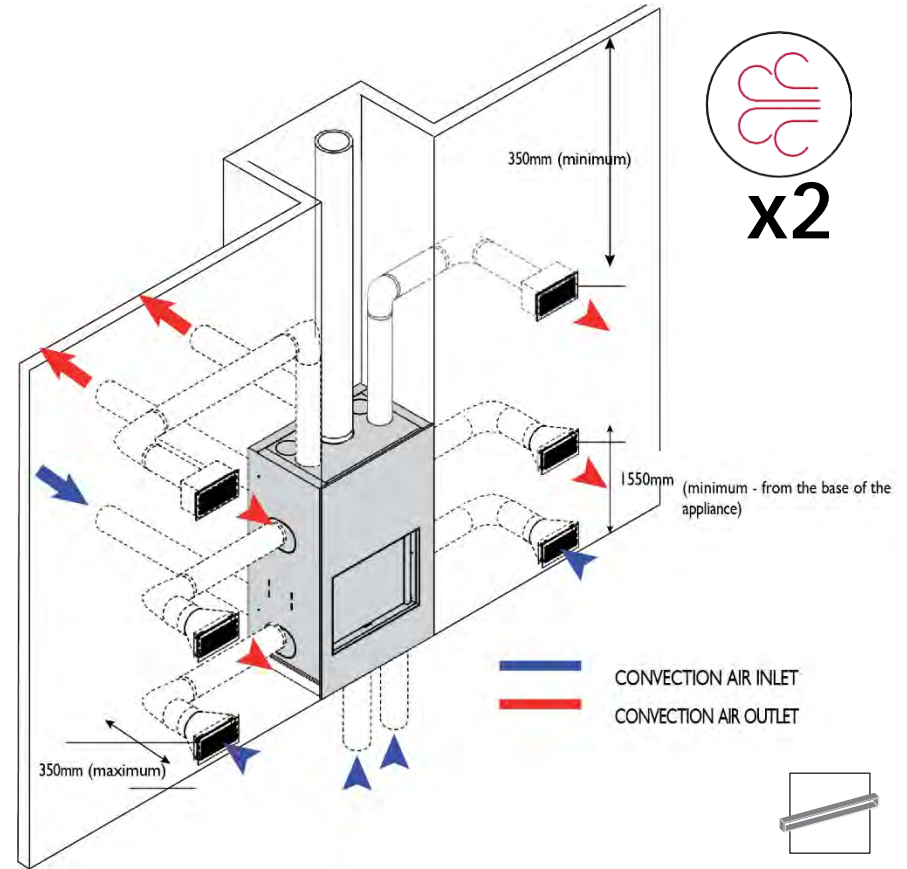

Before starting the installation, it is important to choose the air inlets and outlets that will be used for the convection system.

A minimum of two intakes and outlets must be connected. Air inlets are located in the lower part of the fireplace. Favor the connection under the fireplace. In the case of a low installation, the bottom pre-cuttings on the sides can be used. For the hot air output we recommend using the top back outlets.

For all questions concerning a non-standard installation, contact www.thefireplace.co.nz

3.8 FITTED TELEVISION

It is possible to install/fit a TV above the unit, wall hung with mantel is recommended. If a recess is created for this purpose a **maximum depth of 100mm** between the television and other objects (walls, frames, etc.). Failure to do so may cause the internal temperature of the product to rise and may result in fire and/or damage to the product.

A minimum distance of 50mm between the back wall and the chimney of the appliance must be respected at all times.

For the **E** dimension please refer to pg X

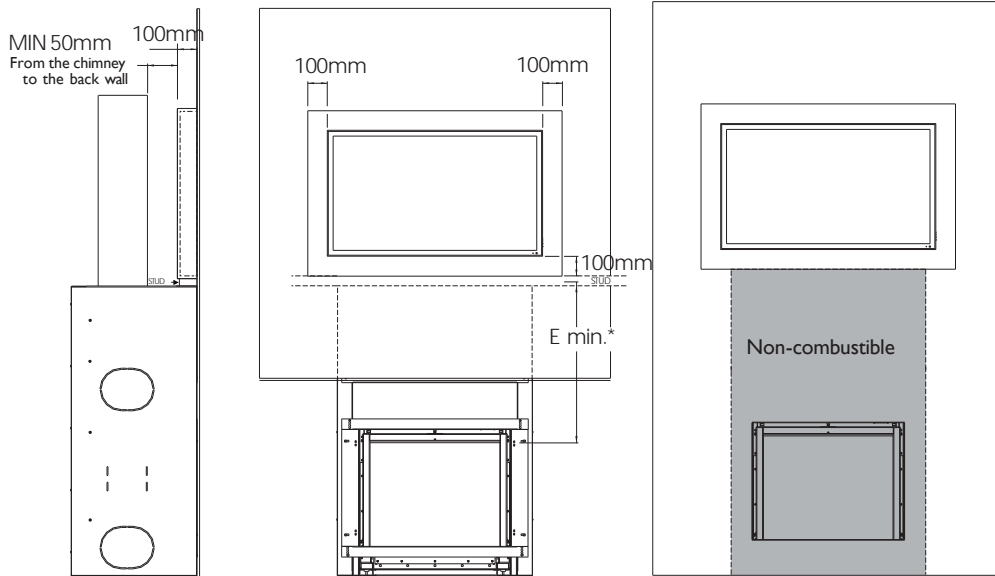

3.9 SHELF MADE OF COMBUSTIBLE MATERIAL



It is possible to install a shelf or decorative object made of combustible material from 400mm of the top of the unit's opening.

In the case of a shelf made of combustible material, it is important to consider the depth of the shelf as this can greatly influence its positioning in relation to the top of the fireplace opening (glass frame).

Use one of the formulas below according to the most important known measurement for a desired installation.

H = Height under the shelf from the top of the unit's glass door

P = Maximum depth of shelf from finished wall

For a specific depth:

$$H = \boxed{P - 3} + 400\text{mm}$$

For a specific height:

$$P = \boxed{H - 400\text{mm}} + 3$$

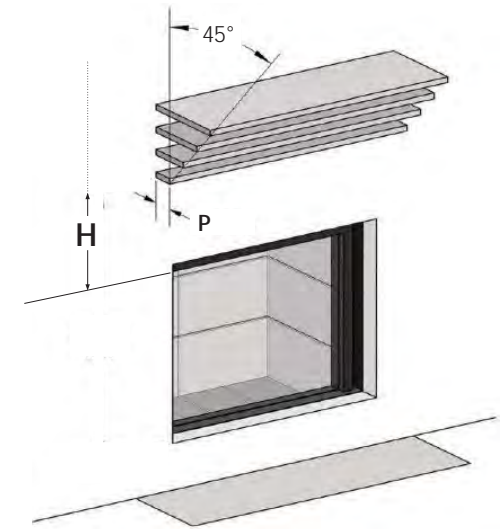

! WARNING

Refer to the installation/operating manual of your TV and follow the instructions. For more information about installation above a fireplace, contact the television manufacturer.



This configuration is at the user's discretion. Stüv does not recommend this installation and disclaims all responsibility.



! NOTE

However, we recommend avoiding placing combustible material that extends over too large an area (e.g. a frame/poster) on the wall above the fireplace. This can trap heat radiation and may lead to a major fire event.

3.10 HEARTH PROJECTION



For an installation aligning the bottom of the glass and the floor, all components must be made of non-combustible material up to a height of 165mm (until below the unit). The thickness of all floor components must be known to ensure perfect alignment of the floor and glass.

The adjustable stand and the two layers of cement board panel under the fireplace are mandatory for this type of installation.

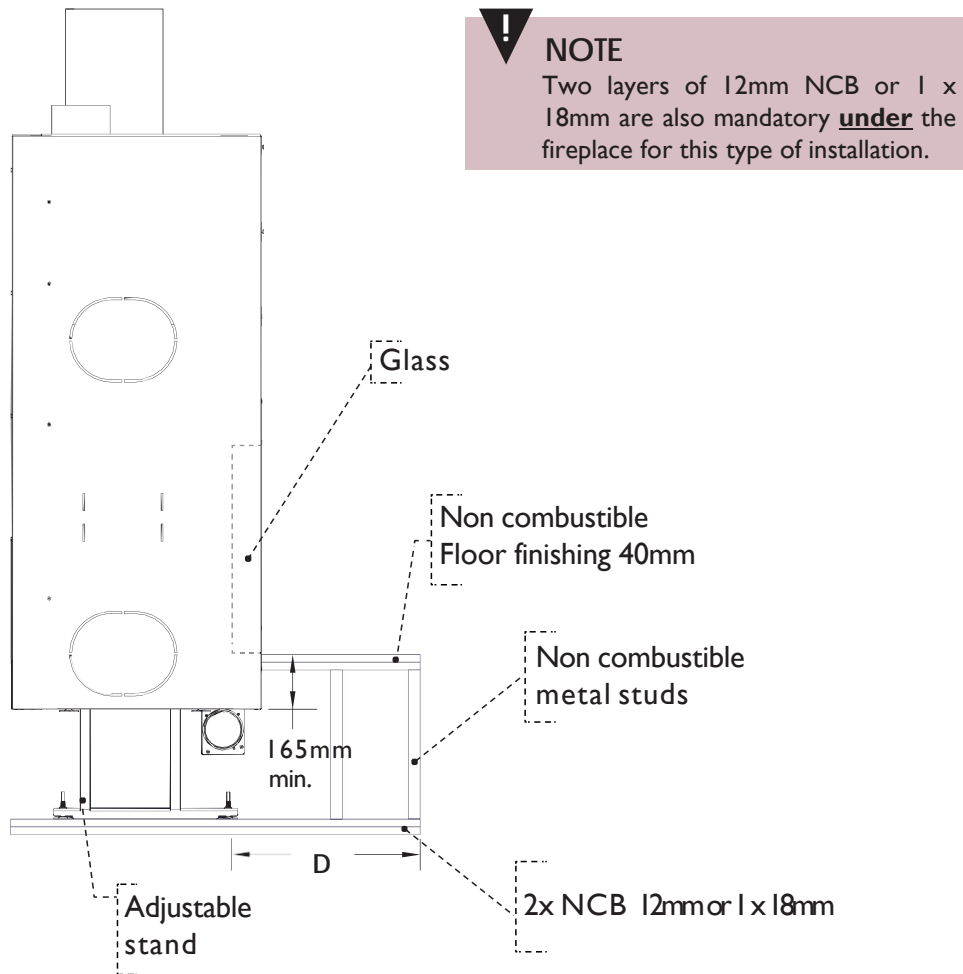

NOTE
Two layers of 12mm NCB or 1 x 18mm are also mandatory under the fireplace for this type of installation.

NOTE
Framing is not always perfectly level. We suggest that at least 5mm clearance be added to the dimensions listed in the table.

MODEL - Hearth	A (mm)	B (mm) **	C (mm)
21-95 SF	1170	600	40
21-105 SF	1270	600	40
21-125 SF	1470	600	40
21-135 SF	1570	600	40
21-95 DF (x 2)	1170	600	40
21-125 DF (x 2)	1470	600	40

NOTE **
600mm projection is measured from the glass front. Projection is 500mm from the front of the appliance wall.

The floor protector can consist of 40mm Skamotec or made up of 18mm board with tile finish = 40mm or 40mm granite, marble or concrete.

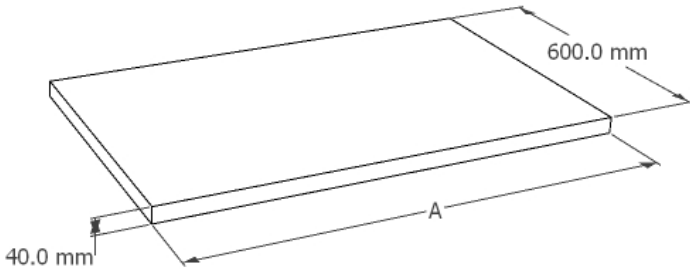

3.11 RISK AREA



The radiation from the firebox is significant. Any combustible object must be placed at a minimum distance of 1200mm by 90° from the face of the firebox to avoid any fire risk.

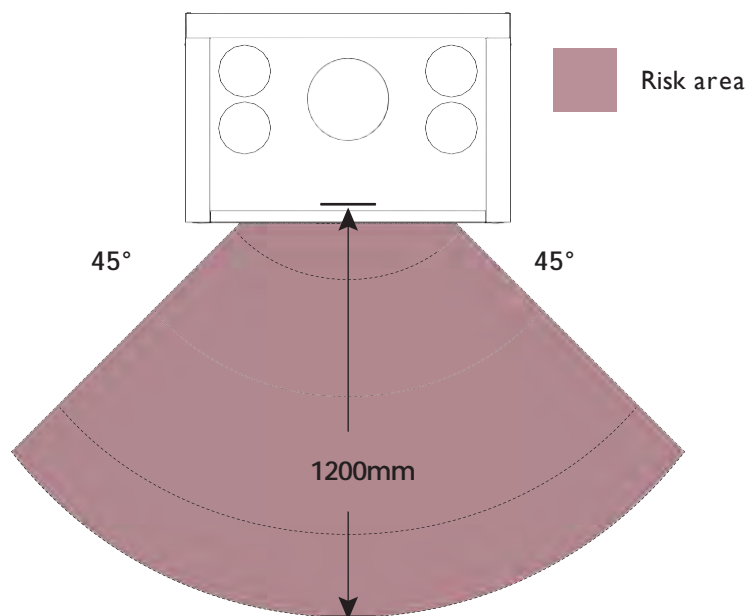
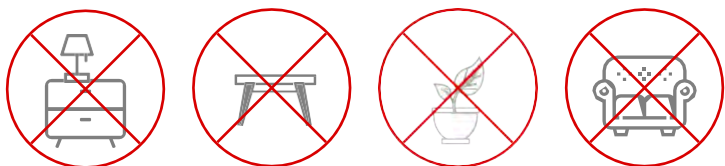

! CAUTION - FIRE HAZARD

To avoid major damage, no combustible material should be placed in front of a hot air outlet. In addition, blocking it may cause the unit to overheat and, in some cases, lead to a fire.

Be sure to follow the above recommendations to avoid heat traps or other major damage risks.

4

INSTALLATION

1.	UNPACKING	25
2.	OPTION: ADJUSTABLE STANDS	28
3.	OPTION: AIRTIGHT BOX	30
4.	DOOR AND PULLEYS	32
5.	PREPARING FOR CONVECTION	34
6.	LEVELING THE UNIT	37
7.	INTERIOR OF COMBUSTION CHAMBER	38
8.	CONVECTION INSTALLATION	42
9.	FINISHING WITHOUT A FRONT PANEL	44

4.1 UNPACKING



! IMPORTANT

The paint is not cured. It is therefore fairly fragile, but it will harden after being heated several times. Handle the unit with care when installing.

Step 1 Remove the cardboard from the front of the stove [photos 1 & 2].

Step 2 Remove protective strip from window [photo 4].

Step 3 Remove vertical front slats with claw [photo 5].

Step 4 Unscrew and remove top section of packaging [photo 6].

! NOTE

Upon receipt of this stove, please ensure that the glass door has not been damaged during delivery. The guarantee only covers damage due to transport if it is reported within 48 hours of delivery and it is indicated on the delivery slip.

Complaints In case of complaints please state our manufacturer's serial number which is visible on the upper right section of the opening [photo 3].

! NOTE

The glass is locked in a central position. Do not unlock the glass at this time to avoid problems later.

1



2



3



4



5



6



4.1 UNPACKING



Step 7 Remove all contents from the combustion chamber including the refractory bricks and vermiculite panels. Check to ensure you have all the required components. Put the foam back on the glass.

The combustion chamber of the single-sided stoves [photo 7] and the combustion chamber of double-sided stoves [photo 8] contain :

- 1 spray paint canister for touch-ups,
- 1 cold grip to handle the door and the valve (2 for double-sided stoves),

– The items as shown in the table below.

7



8



9



CHECK LIST

Is the equipment complete and in good condition?

Model	Reflector Plates	Dimensions L x W x D	Seal	Screws for top extension or closing lid	Locking pieces for refractors [photo 9]	Stainless steel items for upper baffle kit	Stainless steel items for lower baffle kit	Vermiculate for lower baffle kit
21-95 SF	18	394 x 194 x 29.5	2m	8	-	2	3	2
21-105 SF	20 3	294 x 144 x 29.5 304 x 144 x 29.5	1.5m	6	4	2	3	3
21-125 SF	20 3	367 x 179 x 29.5 354 x 179 x 29.5	2m	10	4	2	3	3
21-135 SF	22 6	294 x 144 x 29.5 354 x 179 x 29.5	2m	12	6	2	3	4
21-95 DF	13 2	439 x 144 x 29.5 439 x 169 x 29.5	2m	16	-	2	6	4
21-125 DF	11 4	439 x 169 x 29.5 439 x 144 x 29.5	2m	20	-	2	6	6

4.1 UNPACKING



Step 10 We recommend that you remove all items from within the combustion chamber to make the stove lighter and easier to move.

Step 11 Insert the Stûv handles on the sides of the insulated shell to manipulate the insulated shell. [photo 10]. Once the handles are in place, remove the insulated shell backwards by lifting it up slightly.

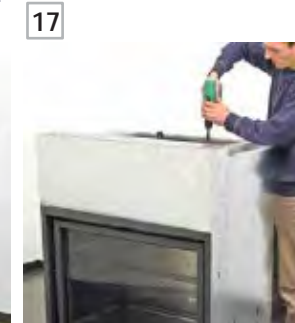
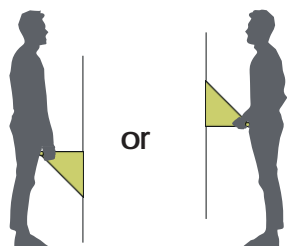

Step 12 Unscrew and remove top section of packaging [photo 11].

Step 13 Once the fireplace has been brought close to its final location, please check that the counterweight cables run in the groove of the pulleys [photo 12].

Step 14 Unlock the counterweights using the 3 mm Allen key [photo 13]. Do not forget to perform this operation before fitting the fireplace into masonry !

Step 15 Make sure the window moves properly ; then raise it to the full [photo 14]

Step 16 Fitting the upper extension or the lid Depending on the option selected, attach the extension (full opening) [photo 15] or the cover plate (partial opening) [photo 16] using the screws supplied with the stove.

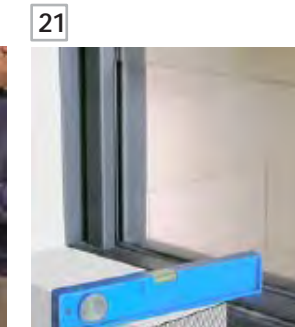
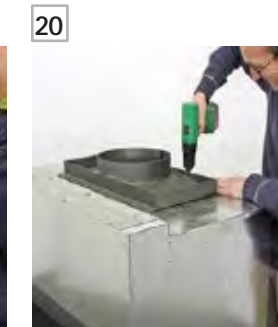

Step 17 Fitting the smoke outlet
Screws are already in place when you receive the appliance. Remove them [photo 17]. Position the seal supplied with the appliance, it ensures air-tightness between the smoke outlet and the hearth body [photo 18].
Fit the smoke outlet (high or low as suitable) [photo 19 or 20].



CAUTION

For perfectly smooth tilting of the door, masonry must be level with the base of the hearth opening [photo 21]

4.2 OPTION: ADJUSTABLE STANDS



NOTE

Follow these instructions for the installation of the adjustable stands. Adjustable stands are highly recommended when installing outside air or simply to raise the unit.

To calculate the height of the adjustable stands, you will need to know the thickness of all floor components in front and under the fireplace. Use the formula below and the illustration to determine the cut-off length of the adjustable legs. Check the minimum height between the finished floor and the bottom of the hearth after insertion into the wall.

Fill in the formula below to calculate the cut-off of the adjustable legs.

$$\begin{array}{ccccccc}
 \boxed{600\text{mm}} & - & \boxed{\text{_____}} & + & \boxed{\text{_____}} & - & \boxed{\text{_____}} & = & \boxed{\text{_____}} \\
 \text{Stand} & & \text{Thickness of floor} & & \text{Thickness} & & \text{Hearth} & & \text{Cut-off} \\
 \text{height} & & \text{beneath the} & & \text{of floor} & & \text{height} & & \\
 & & \text{fireplace} & & \text{finishing} & & & &
 \end{array}$$

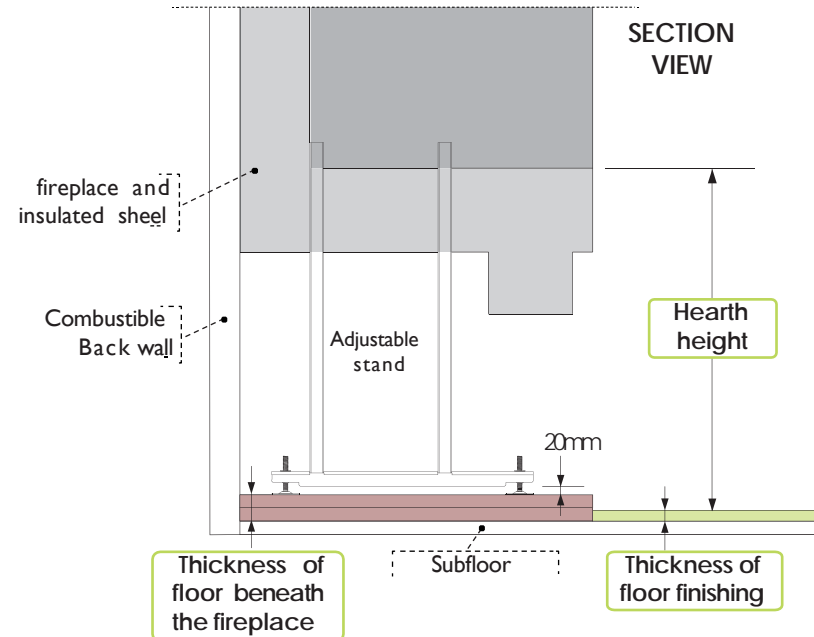

Step 15 The minimum height requirement when installing an airtight box is 200mm from under the fireplace to floor. If the stands are cut too short the airtight box will touch the floor and will be damaged. If not cut the unit will be raised 450mm from the floor.

Step 16 Identify the direction of the stands. Unscrew the feet by 2mm to level the fireplace in both directions when it is in its final position.

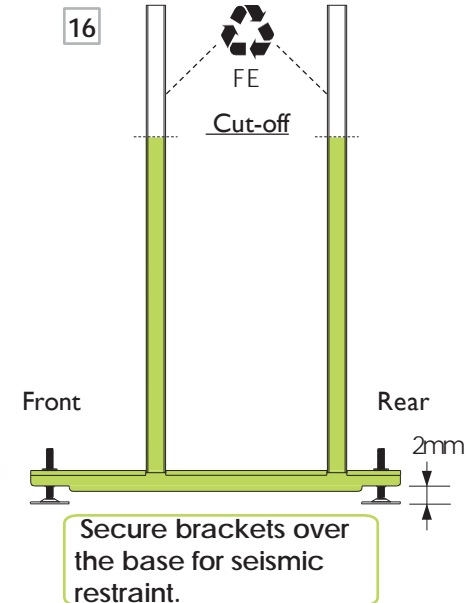
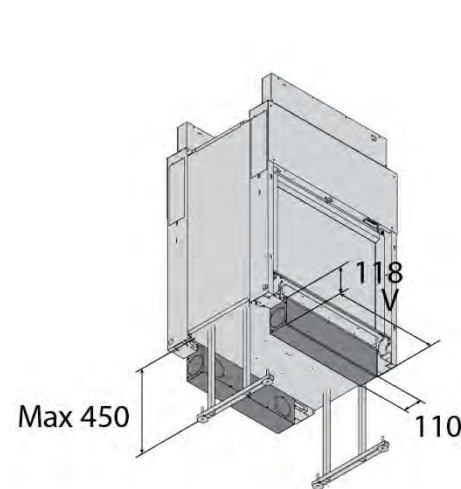



OPTION : Adjustable Stand

Step 17 Cut the adjustable stand with a disc cutter according to the cut-off dimension calculated on the previous page.

Step 18 Using a flathead screwdriver, remove the four access squares for the adjustable stands.

Step 19 Using a hammer, insert the adjustable stands into the access squares you just cleared.

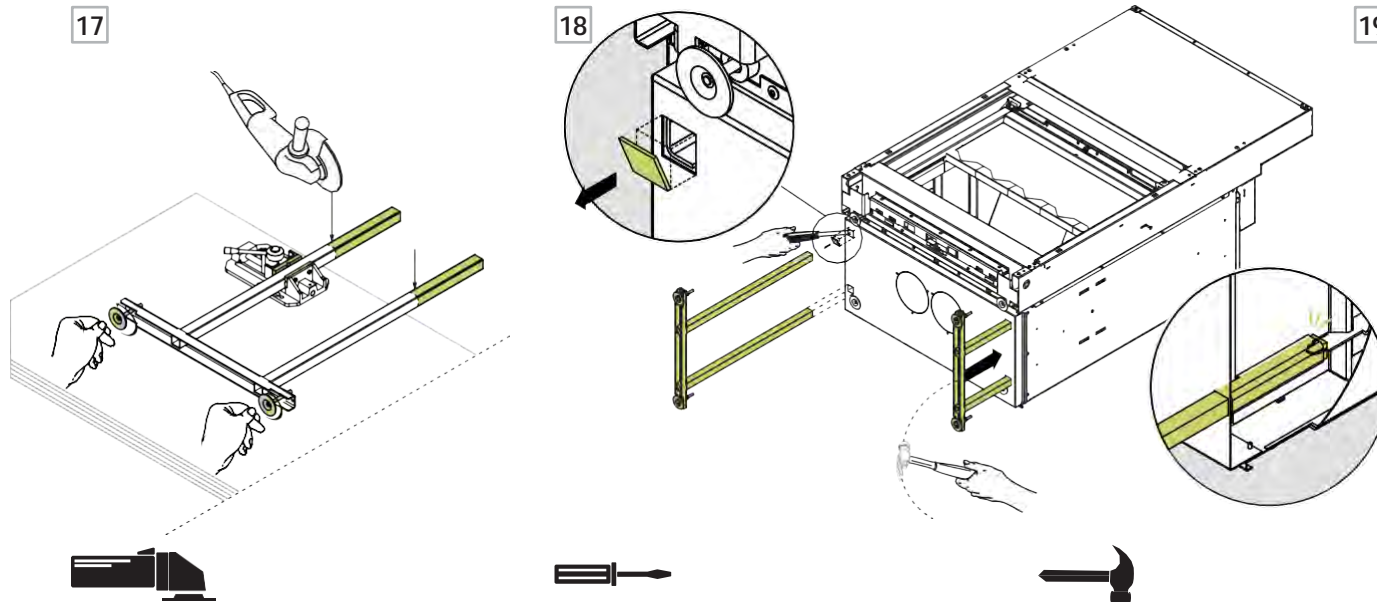



COMBUSTION AIR

Linear access to the front of the fireplace feeds the combustion air that will be expelled through the chimney.

Option 1 Without airtight box

Option 2 The airtight box with an external air inlet and air damper.



NOTICE

Refer to the damper manual if this option have been selcted.



SUB-OPTIONS

1.1 A 150mm opening in the wall near the fireplace. The underside of the fireplace must allow air circulation and the room must not be airtight.

1.2 (not recommended) Use the outside air connection kit to supply air under the fireplace. The area under the fireplace needs to be insulated with non-combustible materials to prevent cold air from entering the room.

2.1 Use the outside air kit to connect the ambient air to the airtight box. Grille not included.

2.2 (recommended) Use the outside air connection kit to connect the outside air to the airtight box. It is recommended to make a loop in the wall with the duct to avoid condensation.

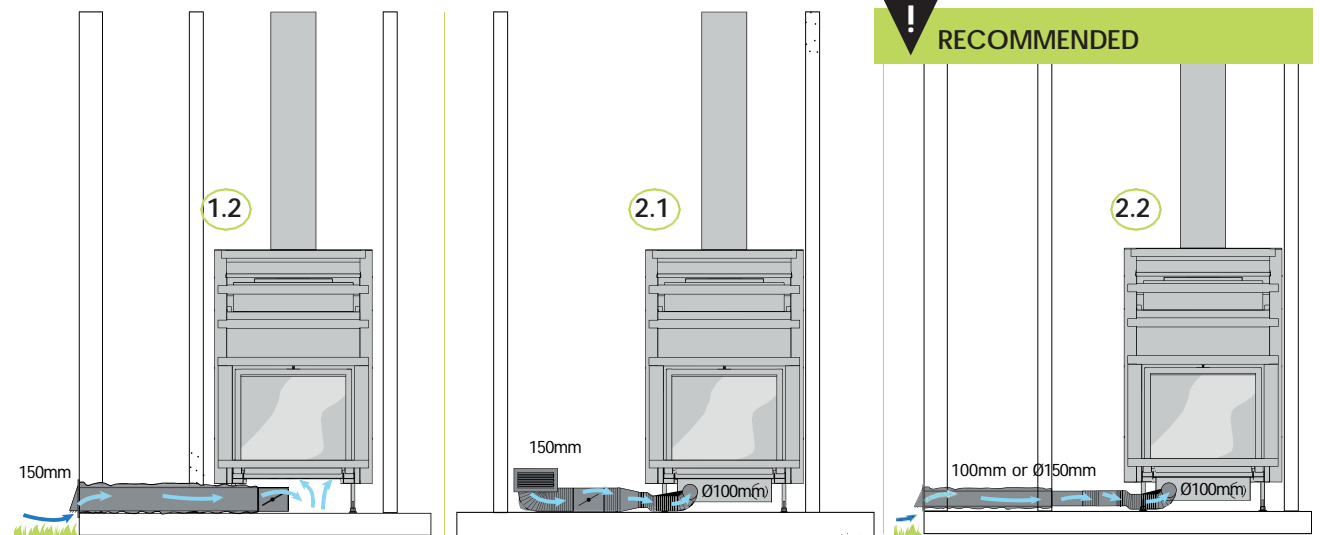
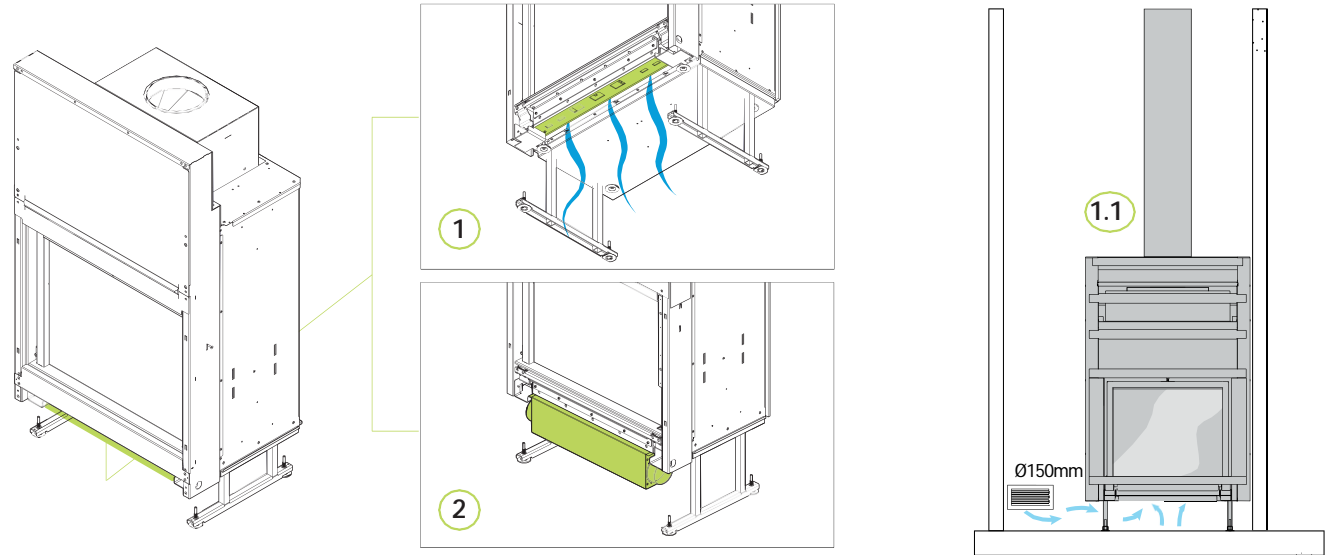

4.3 OPTION: AIRTIGHT BOX



Step 22 Affix the self-adhesive gasket of the airtight box on the upper rim.

Step 23 Using the 3 self-drilling M6 screws provided, secure the short flange to the chosen side.

Step 24 Attach the duct to the short flange using a clamping collar.

22

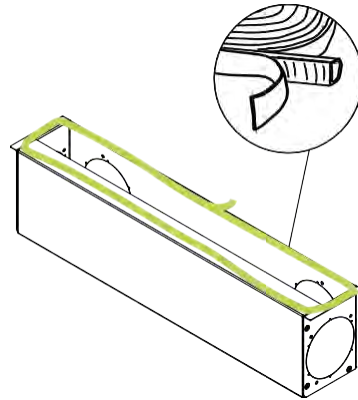

23

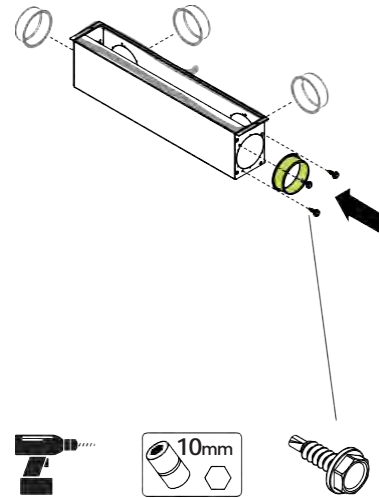

24

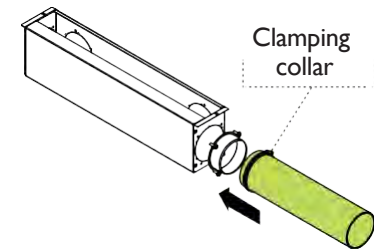

Step 25 For DF model, connect the airtight boxes together at the end that is opposite to the external connection. It is recommended to have a 150mm outside air inlet for 21-95 DF and 21-125 DF models.

Step 26 Position the airtight box in its correct location under the fireplace.

Step 27 Attach the airtight box to the fireplace with two screws.

25

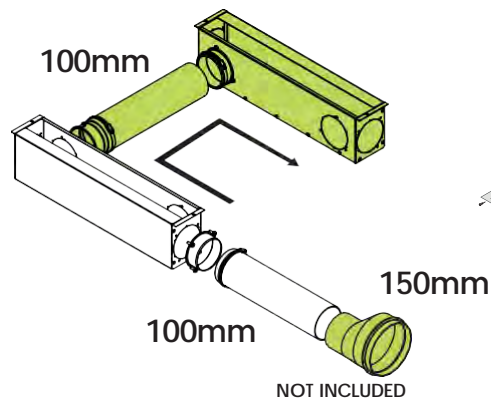

26

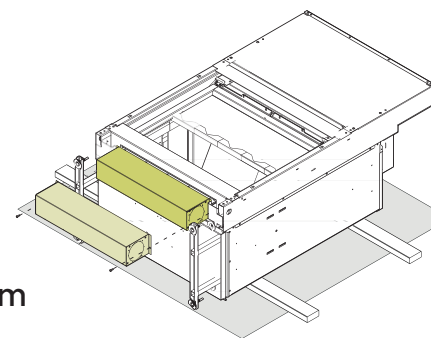

27

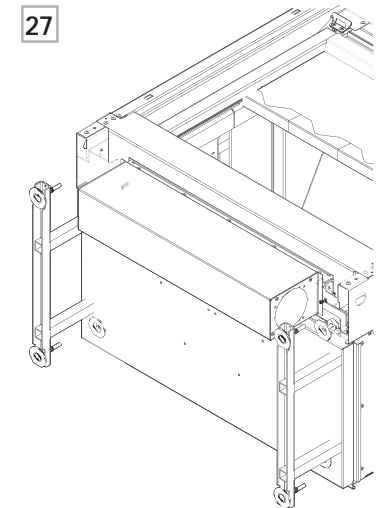

4.4 DOOR AND PULLEYS



NOTE

To avoid damage to the airtight box, no pressure should be put on it when the fireplace is raised.

Step 28 Raise the fireplace to a vertical position on the adjustable stands.

Step 29 Hold the door.

Remove the 2 screws holding the glass on each side before opening the door.



NOTE

This step will be hard to complete after inserting the fireplace into the wall. Make sure the cable is well placed **now**

Step 30 Slide the glass up and down to make sure it is working properly. In case of problems, refer to the illustration below to replace the pulley cable back into its place.

Step 31 Remove the screws that hold the front cover in place and remove the cover by sliding it down and slightly out at the bottom.

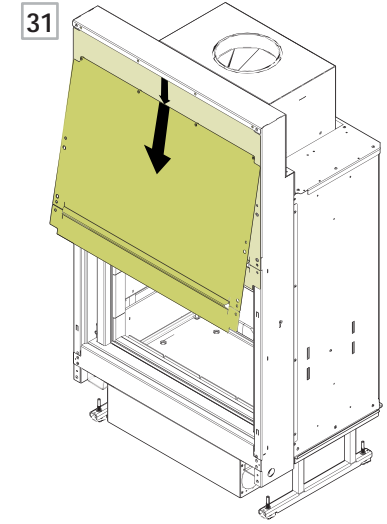
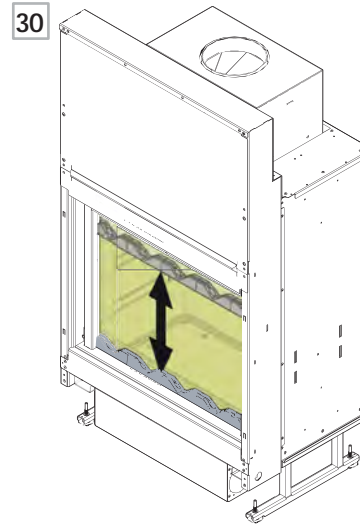
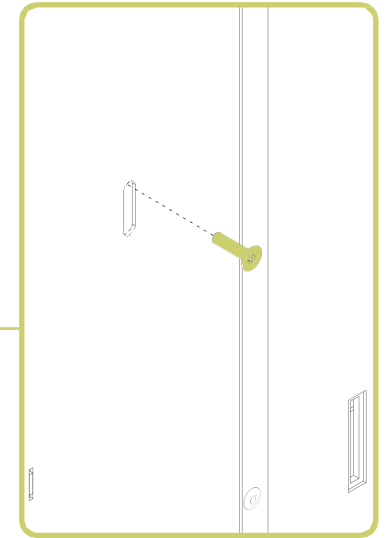
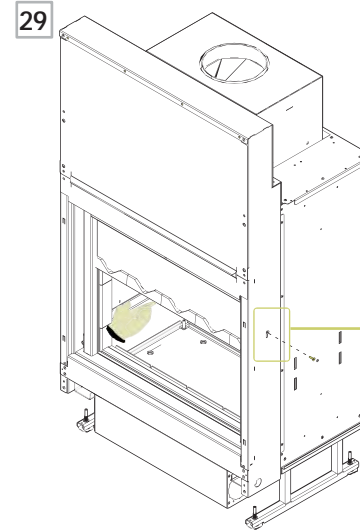
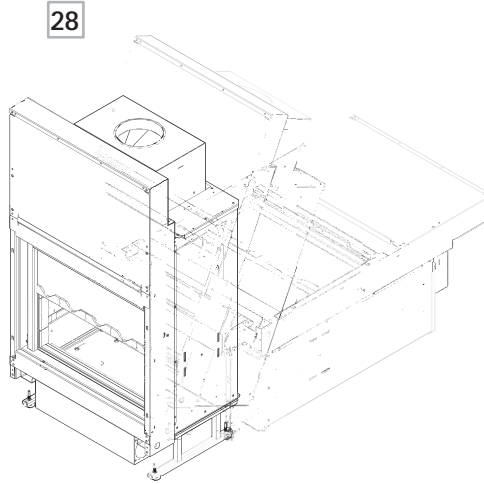

4.4 DOOR AND PULLEYS



Step 32 Visually inspect the pulley cable to validate it is resting onto the recess of the pulley on both sides (left/right) of the fireplace. This ensures ease of movement of the glass.

Step 33 If it is displaced, replace it onto the recess of the pulley.

Replace the front cover once inspection is complete.

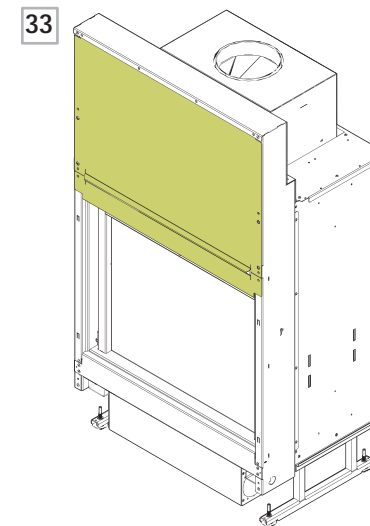
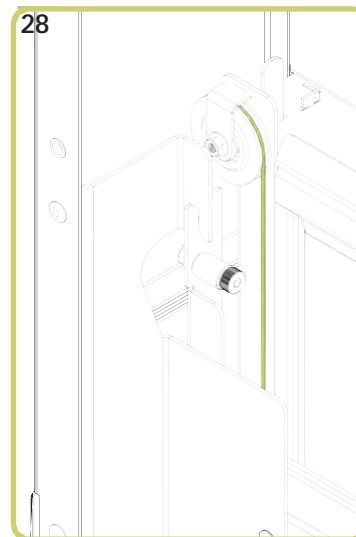
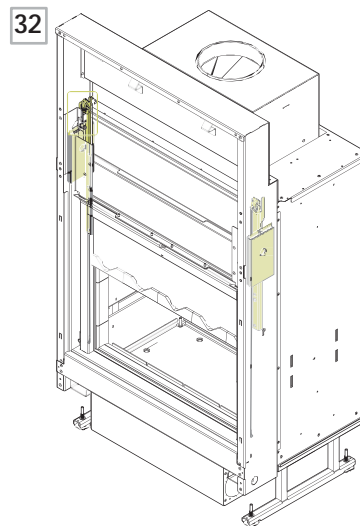

Step 34 Determine which cold air inlets and hot air outlets will be used.

If the side inlets or outlets will be used, prepare the Hebel shell before inserting into wall structure.



LATERAL CONVECTION AIR

34

35

36



! STANDARD INSTALLATION

Step 37 Open the box containing the convection kit:

CONTENT

- 1. 2x Aluminium insulated duct
- 2. 2x Aluminium non-insulated duct
- 3. 2x Flange Ø6" X 24 1/2"
- 4. 2x Flange Ø6" X 3"
- 5. 4x Maxclip
- 6. 8x Gear clamp
- 7. 12x Self-drilling screw

The installation of the linear grille is explained in the annex.

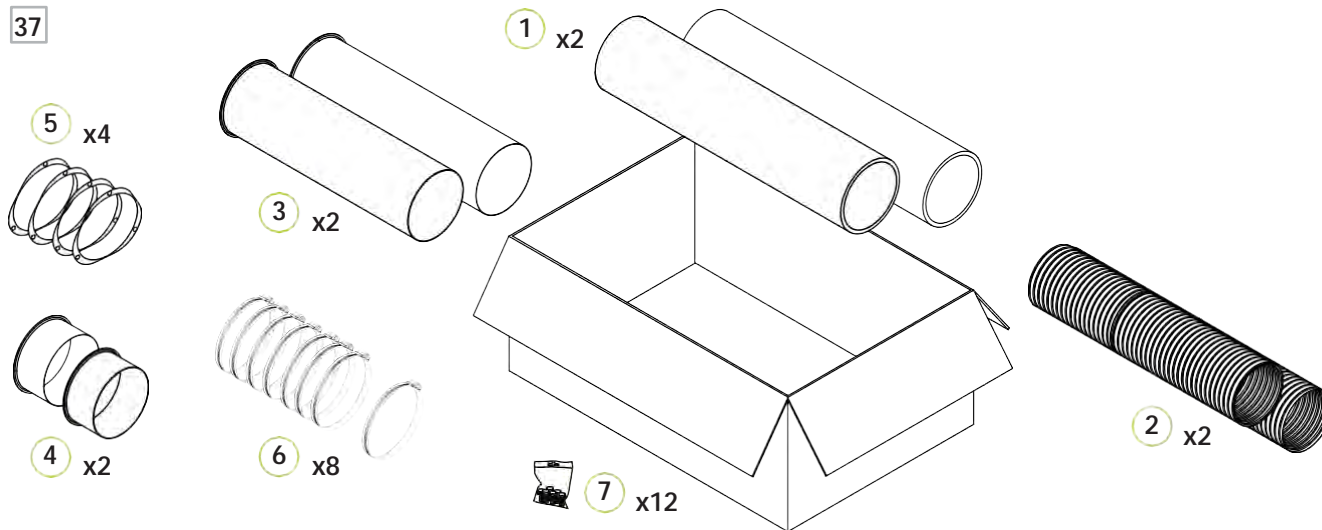

4.5 PREPARING FOR CONVECTION



Step 38 Install the two cement boards on the floor in the opening where the fireplace will be installed.

Step 39 Even out the surface in front of the fireplace with cement board cuttings so that the fireplace can be later pushed into the opening.

Step 40 The wall insertion can be done in two steps by adding wood structures a little bit higher than the bottom of the fireplace.

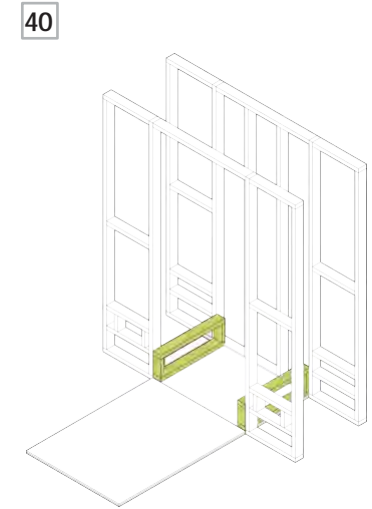
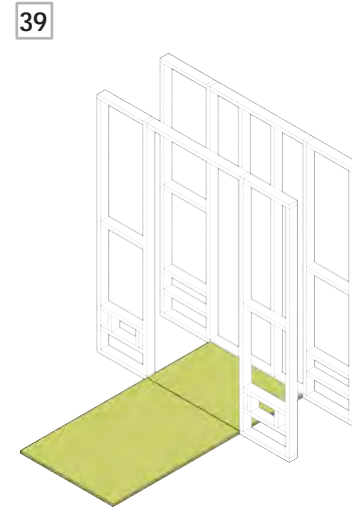
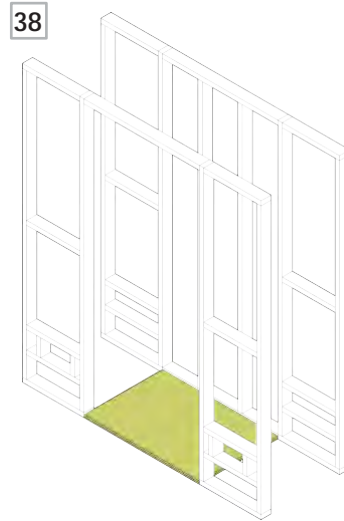

LATERAL CONVECTION AIR

Step 42 When using the side inlets, always connect, connect a 'Ø150mm x 700mm short flange to the opening with the maxclip and the self-drilling hex head screws on both sides.

Step 43 When using the side inlets, always remove, remove the pre-cut side openings of the fireplace (bottom right and left).

The cutouts will fall into the fireplace, this is normal, it is safe to leave them there.

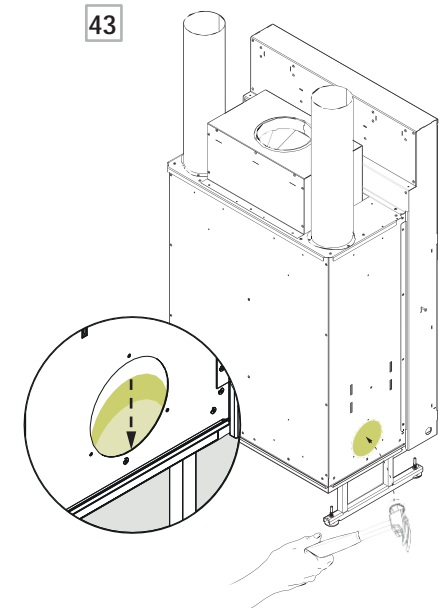
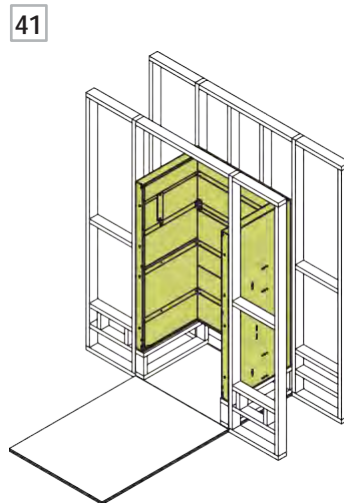



TOP CONVECTION AIR

Step 44 Using a hammer, remove the pre-cut pieces of the top rear openings of the fireplace.

Step 45 Using a hammer, remove the pre-cut pieces of the top rear openings of the fireplace.

Step 46 Connect a $\text{Ø}150\text{mm} \times 620\text{mm}$ long flange to both upper rear exit of the fireplace using the maxclip and self-drilling hex head screws.

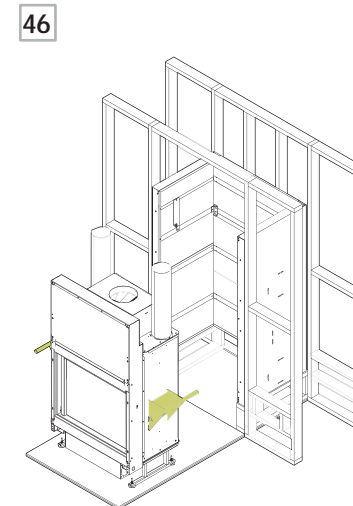
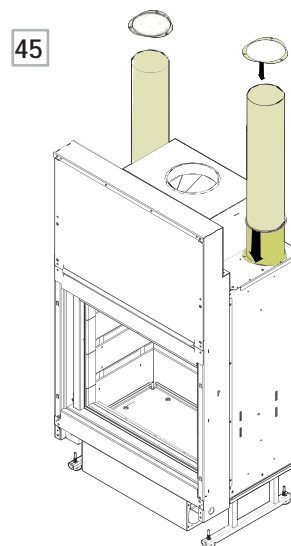
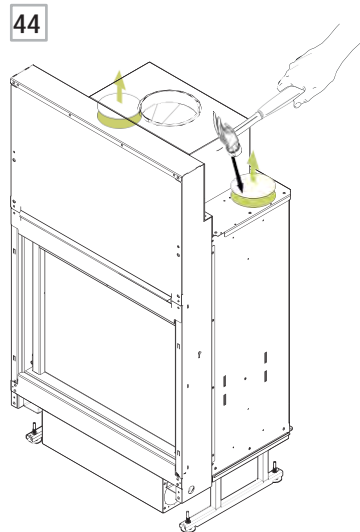

Step 47 Move the fireplace into its final position inside the insulated shell.

Step 48 Remove the wood support structures. The insulated shell will now rest on the unit.

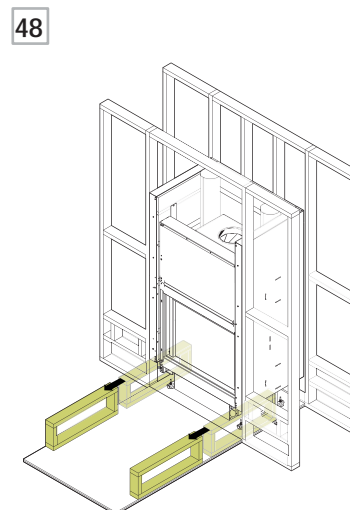
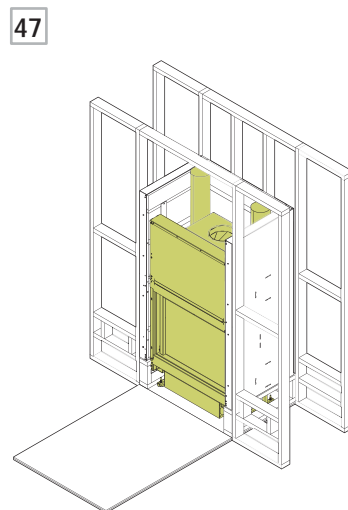

4.7 LEVELING THE UNIT



Step 59 Using a level, make the adjustments as indicated in the following steps.

Step 60 With the adjustable stands, the height adjustment is made with a 5 mm Allen key. Turning clockwise raises the fireplace.

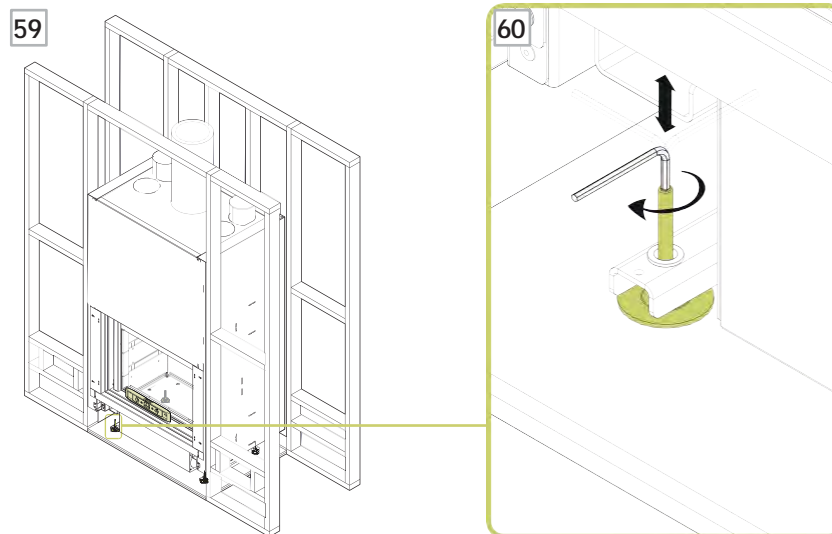

Step 61 Without the adjustable stands, legs can be adjusted at the four corners inside the combustion chamber.

Raise the glass all the way up.

Use a 5 mm Allen wrench or a screwdriver with a 5 mm hexbit to make the adjustment.

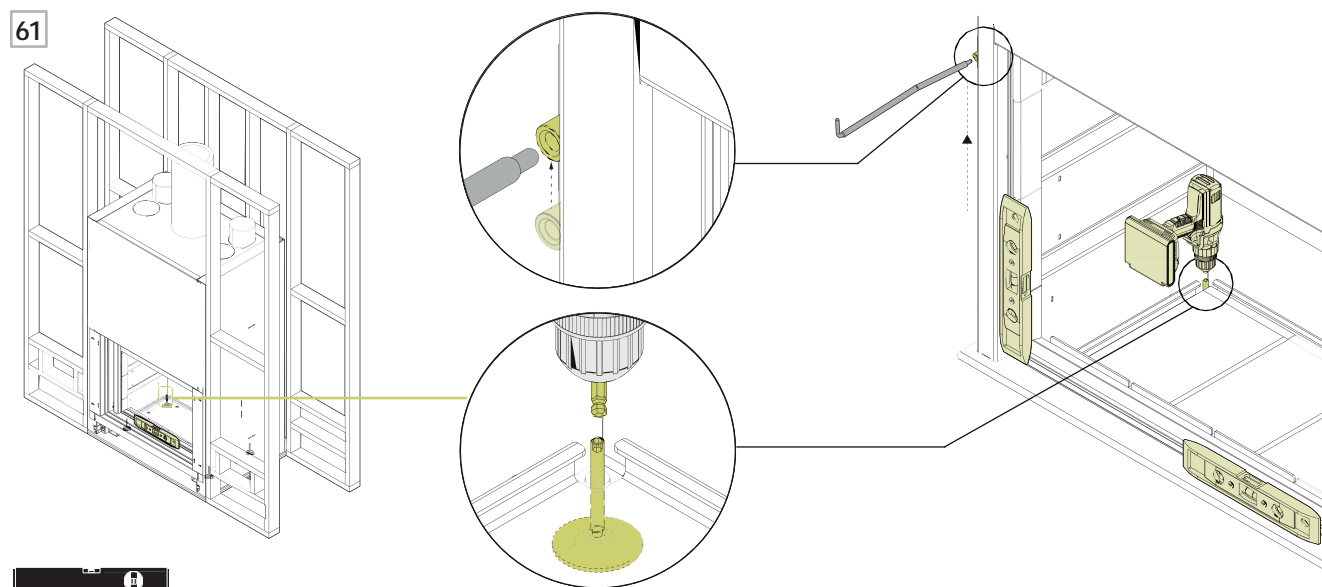

4.8 INTERIOR OF COMBUSTION CHAMBER

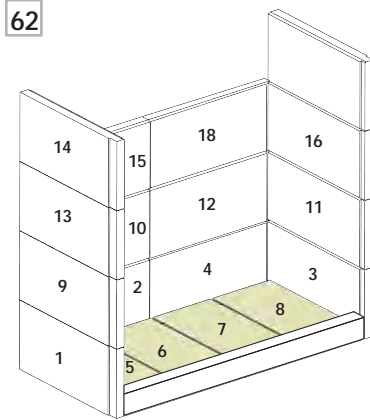

21-95 SF

- PW5010101100 x14 (194 x 394 mm)
- PW5010213500 x4 (190 x 308 mm)

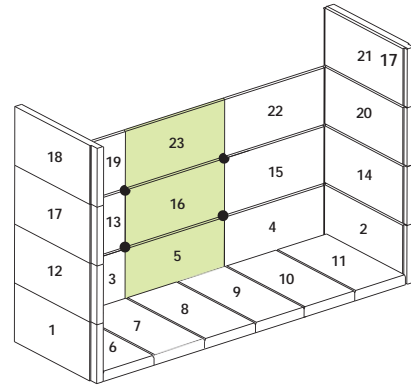

21-105 SF ▼

- PW5010100800 x20 (144 x 294 mm)
- PW5010100100 x3 (144 x 304 mm)

● Refractory tightening clips to be installed

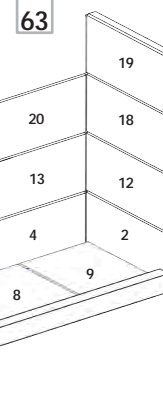

21-125 SF ▼

- PW5010100200 (179 x 367 mm) x14
- PW5010213600 (283 x 265mm) x4
- PW5010100300 (179 x 354 mm) x3

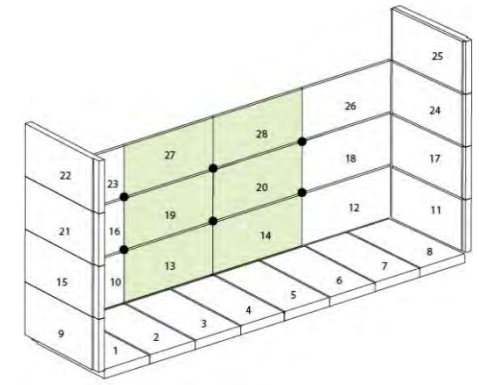

21-135 SF ▼

- PW5010100800 x23 (144 x 294 mm)
- PW5010100100 x6 (144 x 304 mm)



NOTE

For 21-105 SF, 21-125 SF, 21-135 SF only, if the refractory bricks on the back follow the steps for installation of the tightening refractory brackets.

Step 62 Identify the model to be installed and pay attention if there are different panels.

Step 63 Follow the order indicated by the arrows when installing the top refractory bricks.

Step 64 Follow the order indicated by the arrows when installing the top refractory bricks.

64

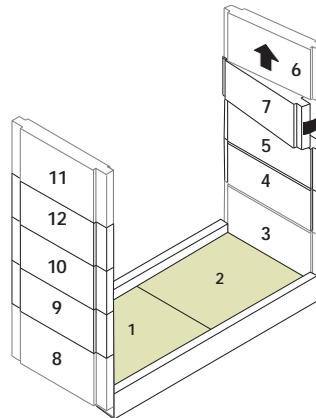

21-95 DF

- PW5010100700 (144 x 439 mm) x6
- PW5010100900 (169 x 439mm) x4
- PW5010200006 (384 x 276 mm) x2

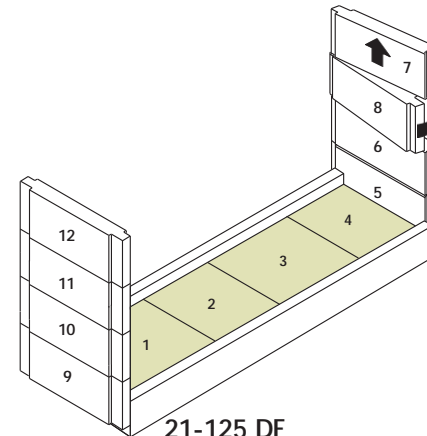

21-125 DF

- PW5010100900 x8 (169 x 439 mm)
- PW5010200007 x4 (267 x 276 mm)



NOTE

Refractory brackets and tightening clips are only provided for the 21-105 SF, 21-125 SF, and 21-135 SF models. These should only be installed if the back refractory bricks are not tight enough.

Step 65 Raise the glass to access the inside of the combustion chamber in order to install refractory bricks 1 and 2.

Step 66 Position the corner refractory brackets behind refractory bricks 1 and 2 in the direction shown. The brackets must be placed **symmetrically**.

Step 67 Place the refractory stone 3 making sure that the small notch is in the front.

Step 68 Press bricks 4 and 5 together to place them to their position.

Step 69 Continue placing the bricks in order. Check the previous page for the black dots, tightening refractory clips must be installed at these places.

Step 70 Once the bottom bricks are in place, push the side bricks to the back to properly secure the bricks and clips.

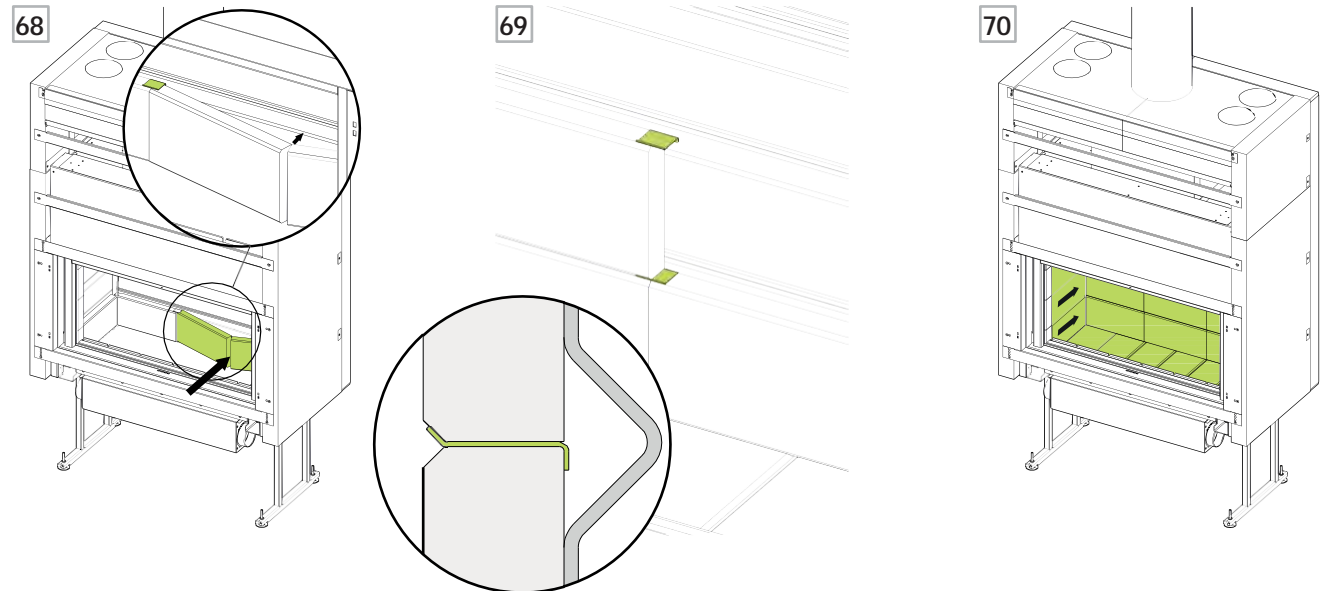
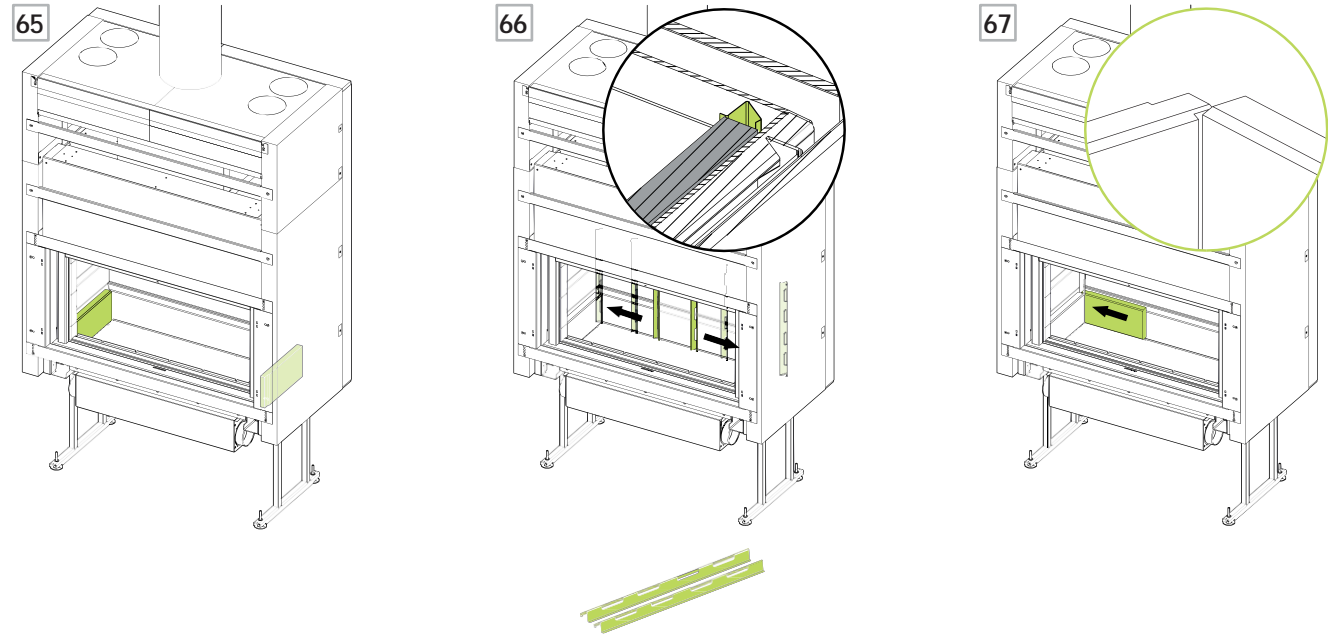



NOTE
For SF models only.
See next page for DF models

Step 71 Insert the pointy end of the baffle support into the notch located on the inside of the fireplace near the door. The small lip must be towards the inside of the fireplace.

Step 72 The other extremity of the baffle support should rest on the top of the highest refractory brick located in the back of the combustion chamber.

Step 73 Repeat the previous steps to install the support on the other side.

Step 74 Place the crosspiece over the supports and insert the two hooks of the crosspiece into the notches in the baffle supports.

Step 75 Slide the vermiculites onto the flat edge of the crosspiece and on top of the back refractory bricks.

Step 76 Place all vermiculites. If there are three vermiculites, finish with the centre one.

MODEL	VERMICULITES
21-95 SF	PW5010203300 x2 (369mm X 307mm)
21-105 SF	PW5010202100 x3 (276mm x 236mm)
21-125 SF	PW5010202300 x3 (346mm X 277mm)

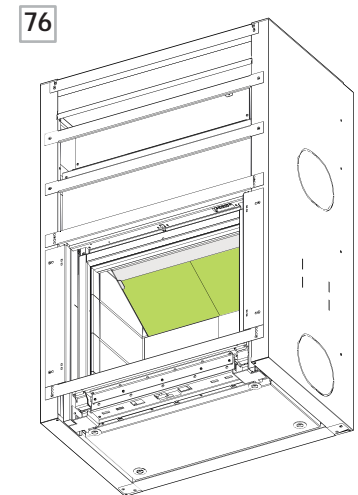
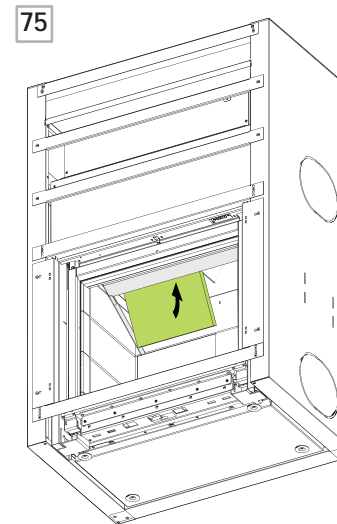
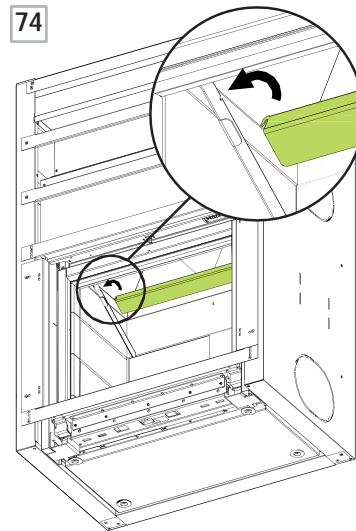
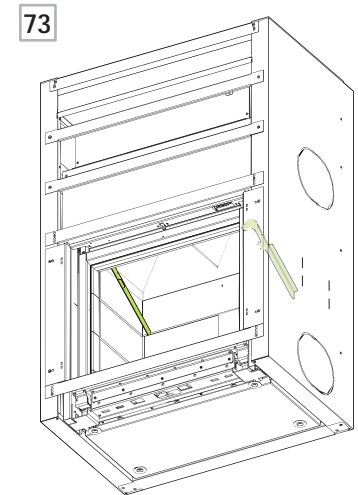
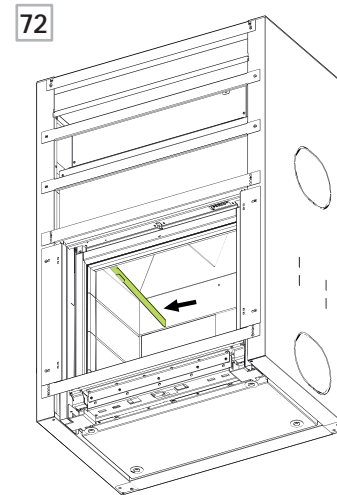
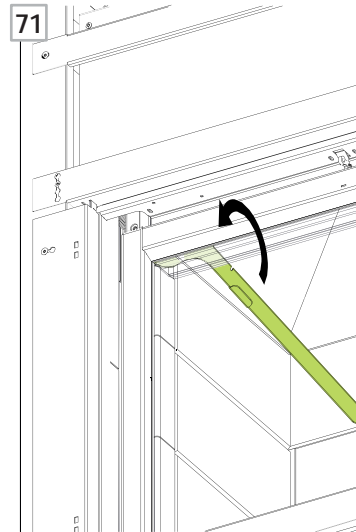



NOTE
For DF models only.

Step 77 Enter the two pointy ends of the baffle support into the notches located on the inside of the fireplace near the doors. The small lip must be towards the inside of the fireplace. Repeat for the opposite side.

Step 78 Place the two crosspieces onto the baffle supports and insert the hooks into the notch on the baffle support.

Step 79 The edges of the crosspieces should be facing towards the glass doors.

Step 80 These crosspieces will be used to install the vermiculites. Make sure they are firmly secured into the notches.

Step 81 One at a time, place the vermiculites between the edges of the crosspieces so they sit on them.

Step 82 Place all vermiculites. If there are three vermiculites, finish with the centre one.

MODEL	VERMICULITES
21-95 DF	PW5010203200 x4 (366mm X 166mm)
21-125 DF	PW5010202200 x6 (345mm X 112mm)

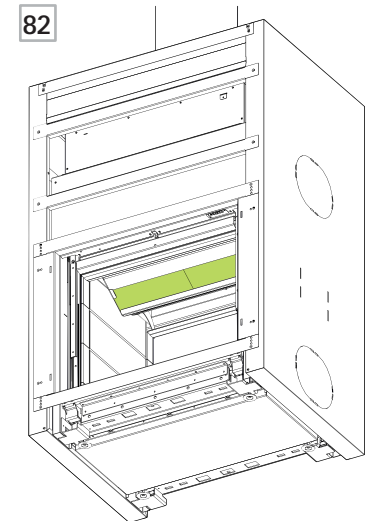
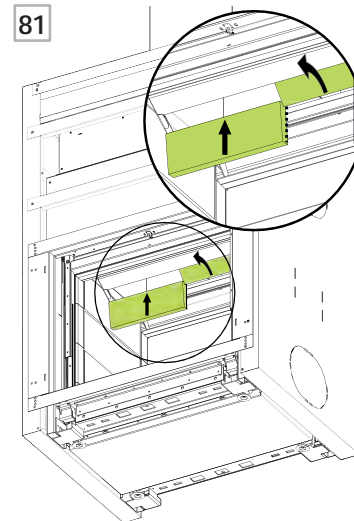
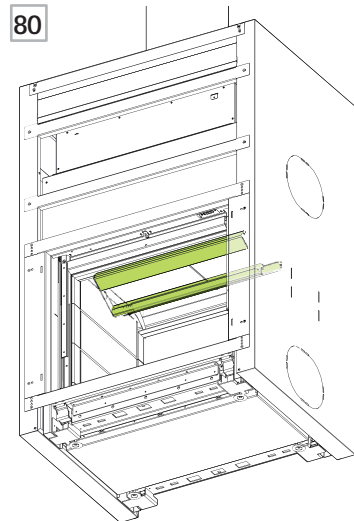
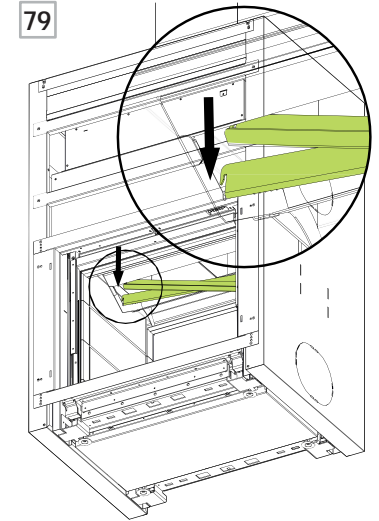
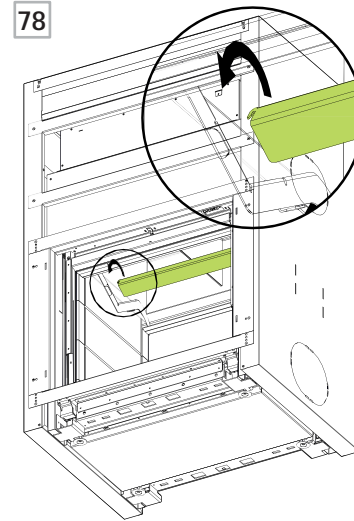
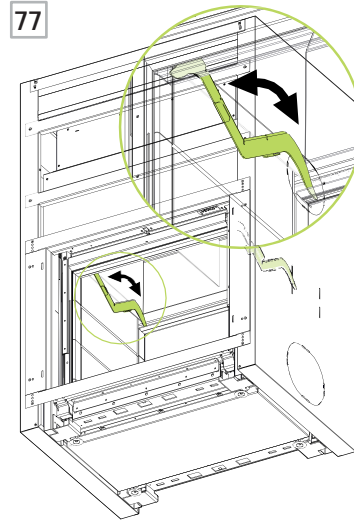



NOTE

The insulated duct shall be used for the hot air outlets and the un-insulated duct shall be used for the cold air intakes. Otherwise, it could pose a fire hazard.

Step 83 Open the 2 convection air kit boxes and separate the cold air inlet and hot air outlet components to facilitate their installation.

Step 84 Connect the flexible ducts to the fireplace as per the chosen configuration.



TIPS

To ease the assembly with the hose clamp, roll back the insulation.

1. Air outlets above the fireplace

Install the insulated air ducts on top of the fireplace with a hose clamp. Rear opening is recommended.

2. Air intakes below the fireplace

Install the un-insulated air ducts below the fireplace with a hose clamp and the convection kit.

3. Air intakes and outlets on the sides and/or back of the fireplace

Install the air ducts on the sides or at the back of the fireplace using a hose clamp. Fill the empty space around the ducts with the previously cut scraps

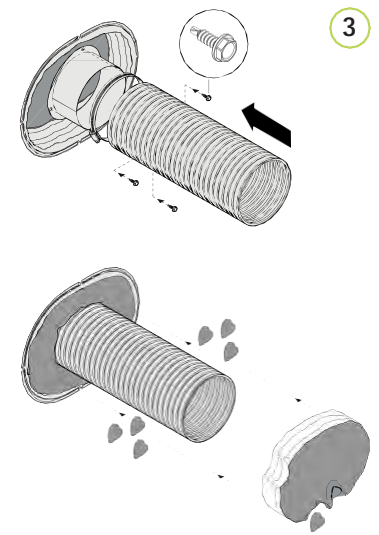
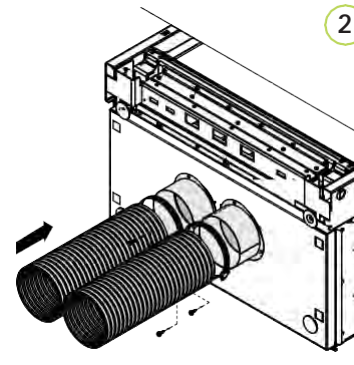
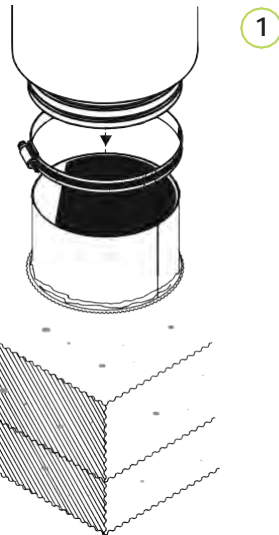
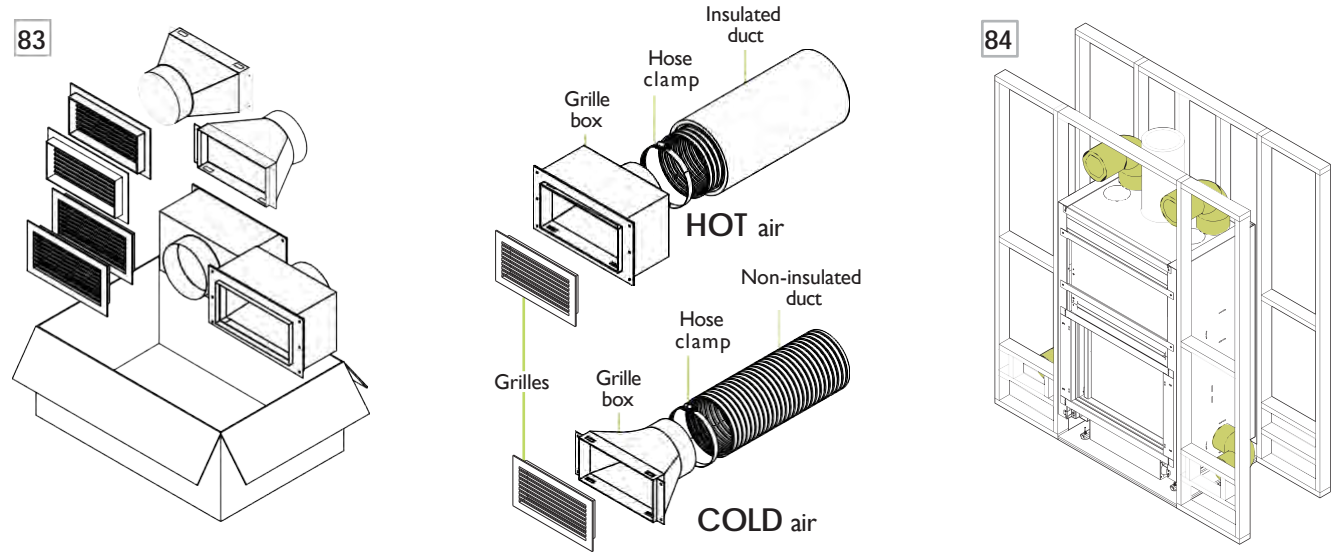

4.9 CONVECTION INSTALLATION



NOTE
The linear grille is installed differently than the standard grilles. See installation manual provided with the linear grill.

Step 85 Position the framing so that the grille boxes can be installed according to the clearance instructions in the **AIR SUPPLY** section.

The framing around the hot air grilles must be non-combustible and adapted for the installation of the 12mm cement board contour.

Step 86 To avoid warping and stress in the material, insert the screw at 90° in the studs.

Step 87 Screw the grille boxes in place. The screws are not included and should conform to the framing material being used.

Step 88 If a finishing frame has been selected, follow the instructions in the installation manual that came with the frame.

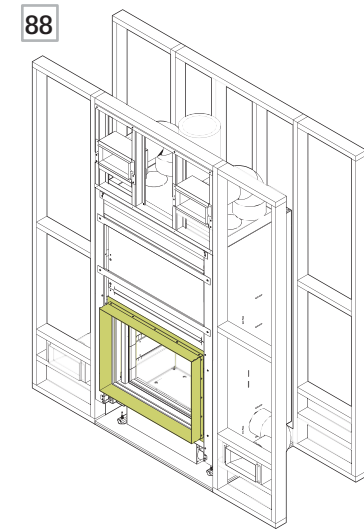
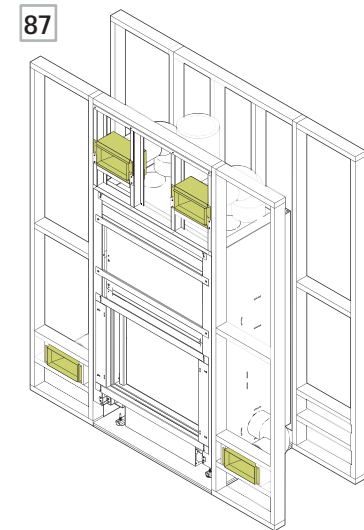
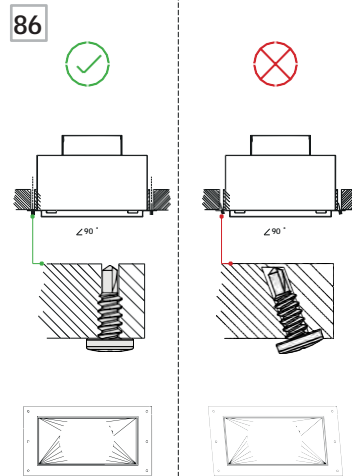
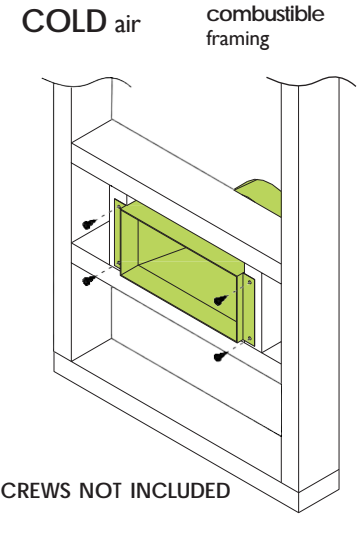
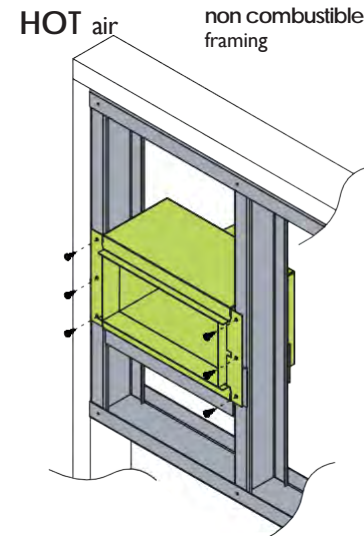
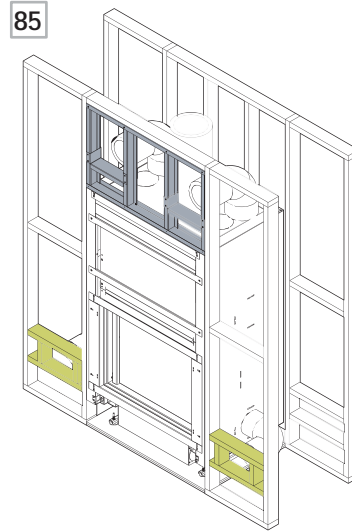

4.10 FINISHING WITHOUT A FRONT PANEL



NOTE

In order to prevent cracks, it is recommended to use a single piece of cement board instead of multiple pieces.



Protect the fireplace door!

Step 89 Cut the 12mm cement board to the right size as indicated in the **DIMENSIONS** section (cavity opening) according to the fireplace model and fix it to the trims of the insulated shell (green sections on the diagram) or to the wall structure.

Step 90 Cut and install the cement board contours around the hot air output boxes and secure it to the metal framing.

Step 91 Install the finishing board to cover the wall and secure it to the framing.

Step 92 Clip the grilles into the grille box already in place.

Step 93 Place finishing angle bars (not included) around the opening of your finished wall to obtain straight angles.

Step 94 Protect the glass and fireplace paint, then proceed to drywall finishing and desired wall finish using **non-combustible materials**.

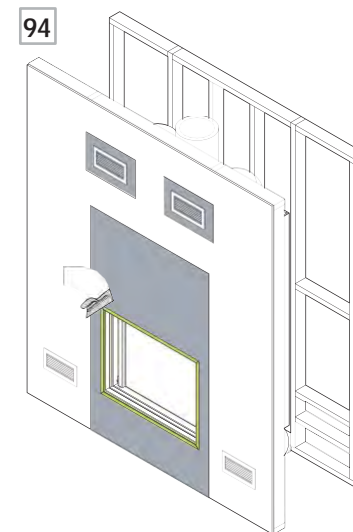
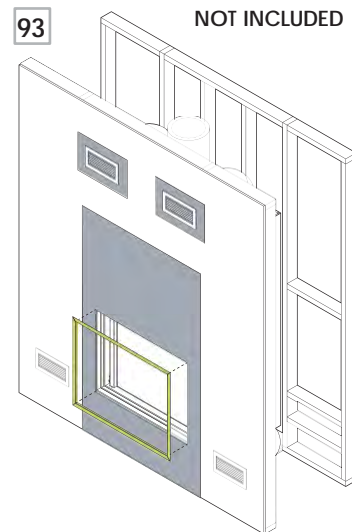
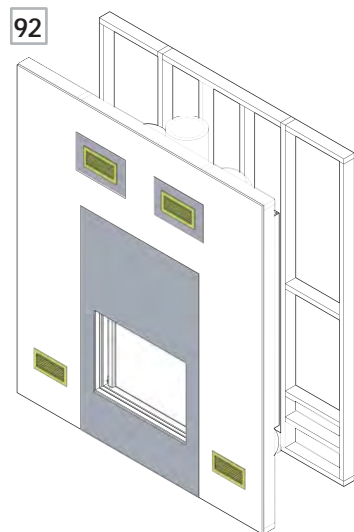
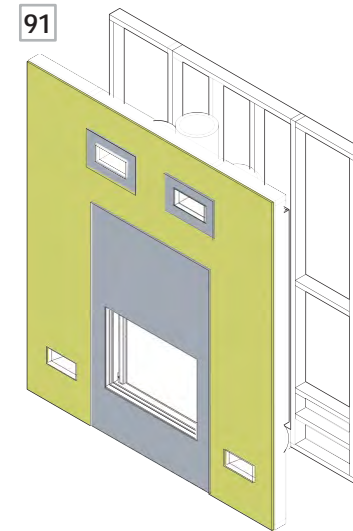
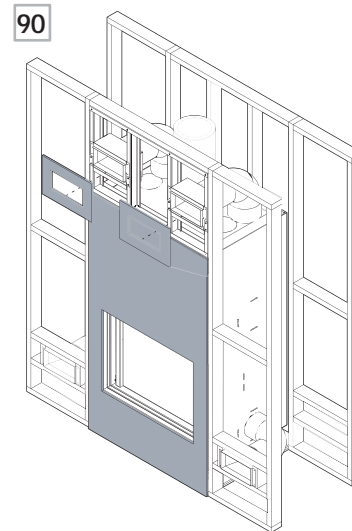
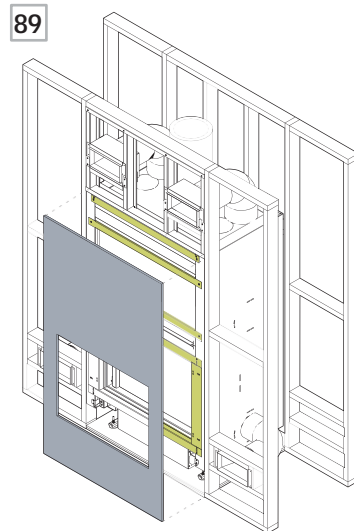

5

CHIMNEY

1.	DIMENSIONS	46
2.	INSTALLATION TYPE	47
3.	FLUE TERMINATION	48

5.1 DIMENSIONS



CHIMNEY DIAMETER

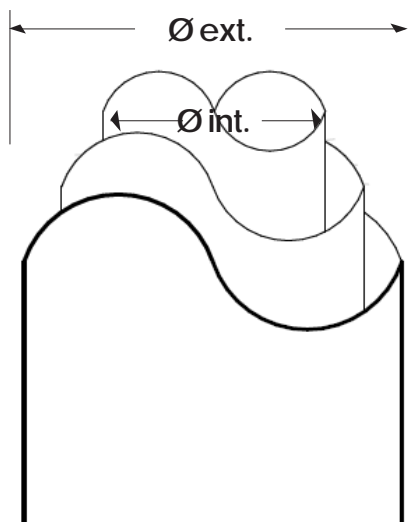

MODEL	Ø int.	Ø ext. †
21-95 SF	250mm	300mm/350mm
21-105 SF	200mm	250mm/300mm
21-125 SF	250mm	300mm/350mm
21-135 SF	300mm	350mm/400mm

MODEL	Ø int.	Ø ext. †
21-95 DF	250mm	300mm/350mm
21-125 DF	300mm	350mm/400mm

CHIMNEY LENGTH

MIN. 4.6M / MAX. 13M
 The chimney height must be between 4.6M minimum and 13M maximum from the bottom of the appliance to below the termination.

Chimney Length
 To calculate the number of chimney sections required, start counting from the top of the appliance. Minimum height is 4.6M. Flue comes in 1.2M lengths.

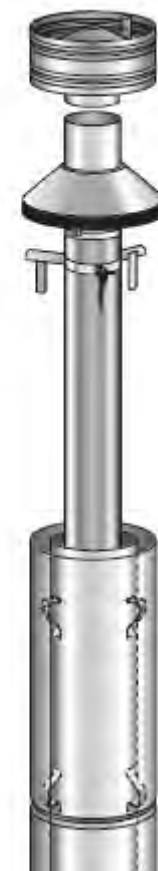

NOTE

- Do not connect the appliance to a chimney that is already connected and used by another appliance. A chimney used as an outlet for a fireplace may not be used for more than one appliance.
- Do not cut trusses, rafters or ceiling joints without consulting a building official to ensure that structural integrity is not compromised.
- It is recommended that a straight section of chimney be installed between the unit and an offset.



Before connecting the chimney, make sure that the fireplace is in its final position and that it is level (Refer to page 37 if necessary).

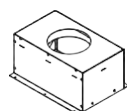

Calculate the required chimney length according to the information on this page and the next one, make sure you have all the required components.



INSTALLATION DIAGRAM

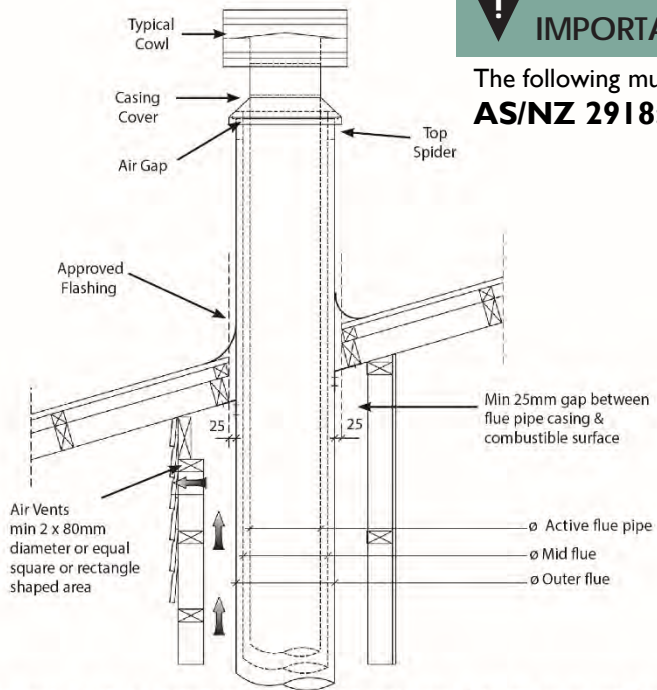

IMPORTANT

The following must be adhered to:
AS/NZ 2918:2001:4.9.1

Note: All external air vents & ceiling penetrations must be bird & rodent proofed with permanently fixed screens

INSTALLATION PROCEDURE

WARNING THE APPLIANCE AND FLUE-SYSTEM SHALL BE INSTALLED IN ACCORDANCE WITH AS/NZS 2918 AND THE APPROPRIATE REQUIREMENTS OF THE RELEVANT BUILDING CODE OR CODES. MIXING OF APPLIANCE OR FLUE-SYSTEM COMPONENTS FROM DIFFERENT SOURCES OR MODIFYING THE DIMENSIONAL SPECIFICATION OF COMPONENTS MAY RESULT IN HAZARDOUS CONDITIONS. WHERE SUCH ACTION IS CONSIDERED, THE MANUFACTURER SHOULD BE CONSULTED IN THE FIRST INSTANCE.

- 1 The flue or chimney system must be in good condition. It must be inspected by a competent person and passed for use with the appliance before installation.
- 2 Products of combustion entering the room can cause serious health risks.
- 3 The flue pipe shall extend not less than 4.6m above the top floor protector.
- 4 The minimum height of the flue system within 3M distance from the highest point of the roof shall be 600mm above that point.
- 5 No part of any building lies in or above a circular area described by a horizontal radius of 3m about the flue system exit.
- 6 Terminate all flues a minimum of 600mm above the highest ridgeline of the donor building.

IMPORTANT

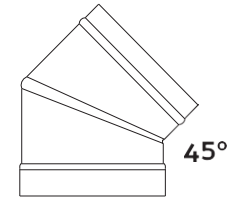

It is preferable to install a straight chimney section between the unit and an offset. One length of flue is recommended. In this case, a straight vertical section must be installed after the angle.

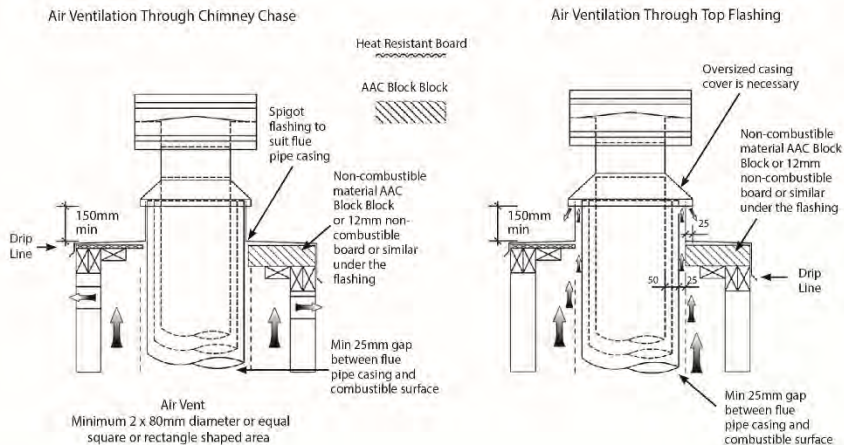

5.3 FLUE TERMINATION



1 If fitting a cladding system to the double sided models creating a freestanding installation, please use the following freestanding flue system.

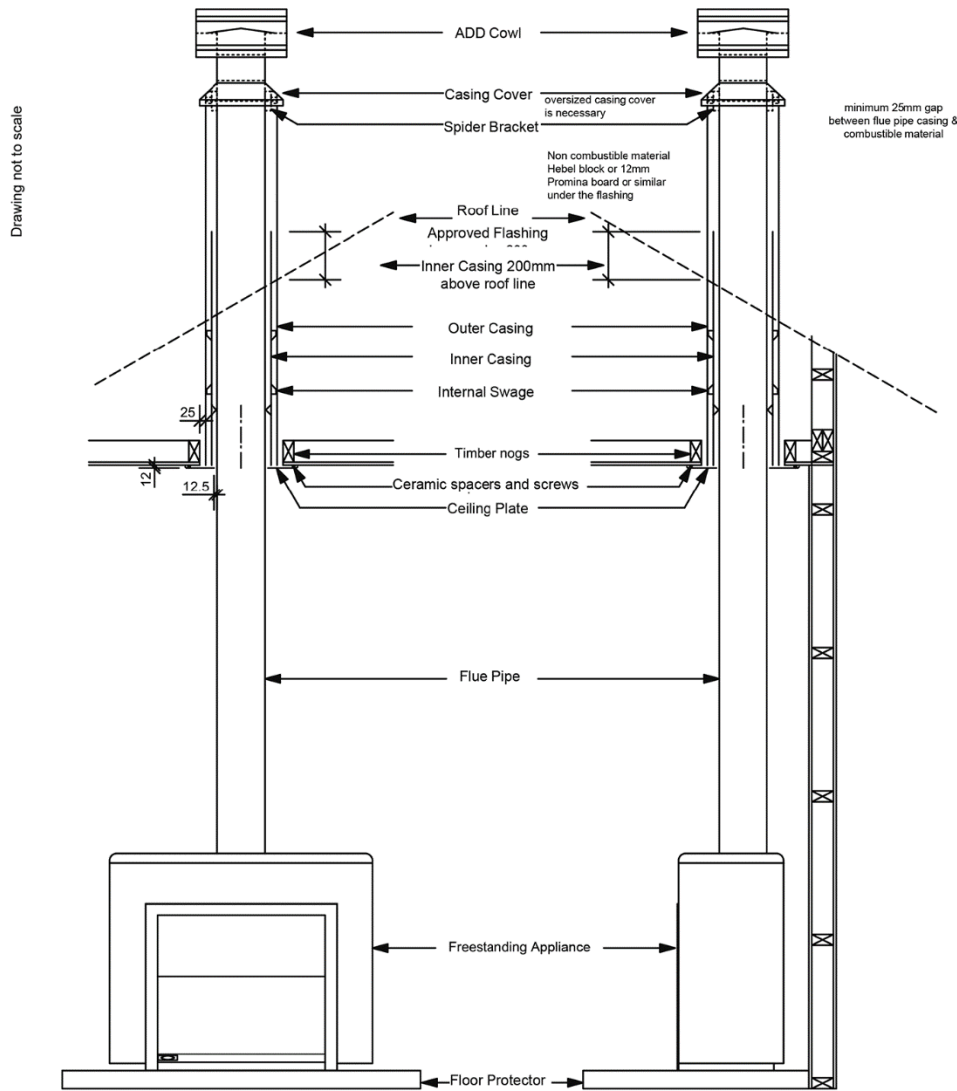

! CAUTION

THE FLUE TERMINATION POSITIONS ARE THE MINIMUM REQUIRED AS PER NZS 2918:2001.

IT IS POSSIBLE THAT FLUE HEIGHTS MAY NEED TO BE INCREASED AS A RESULT OF CONFLICTING AIR PRESSURE ENVELOPES THAT MAY DEVELOP OVER SOME ROOFLINE SHAPES AND SURROUNDING OBSTRUCTIONS.

RESTRICTION INTO CLEAR AIR MOVEMENT OVER ANY ROOF MAY ALSO REQUIRE DIFFERENT COWL DESIGNS, PARTICULARLY FOR HIGH WIND ZONES OR VARYING LOCAL ENVIRONMENT CONDITIONS.

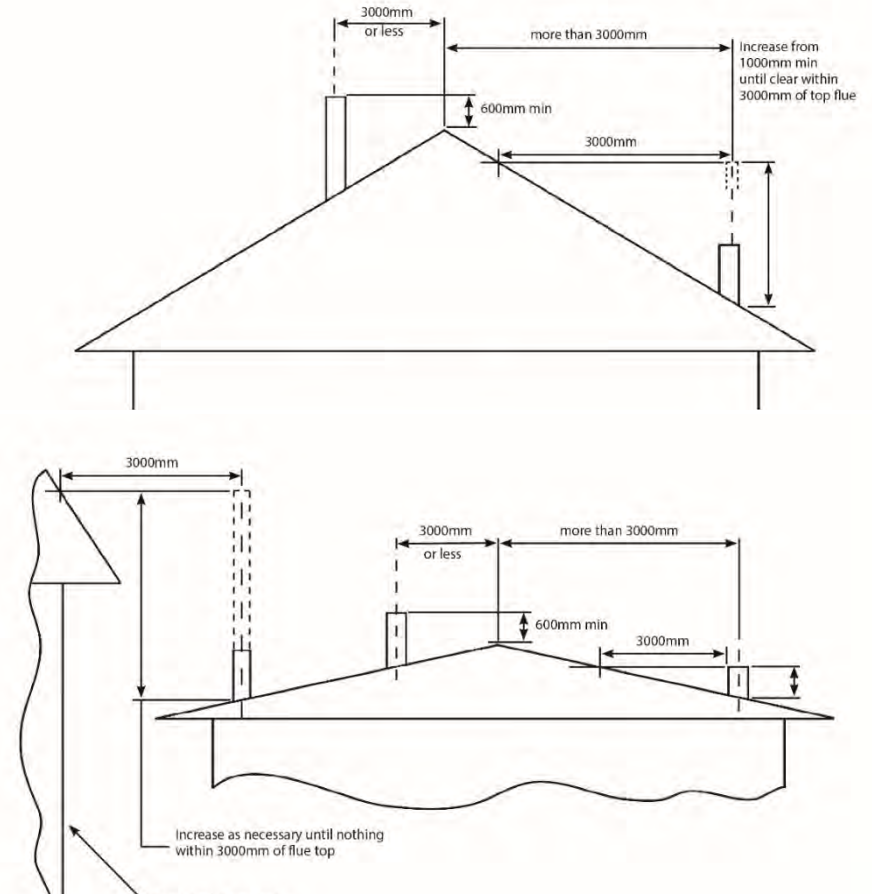

6

USE

1.	WOOD SELECTION	50
2.	DO NOT USE	51
3.	STARTING THE FIRE	52
4.	RELOADING THE FIRE.....	53
5.	ASH REMOVAL	53



HUMIDITY LEVEL

It is essential to use **dry wood** that has a moisture content of **less than 18%**. This will ensure **more efficient and clean combustion**.

Using **wet or semi-dry wood** with a moisture content **higher than 18%** will result in mediocre and less efficient combustion. The fire will be smaller and difficult to start. It will release a great deal of **black smoke and pollution** into the air and also sully your glass pane and chimney pipe.

To choose dry wood, use a moisture meter or check if...

- The wood is lightweight and slightly split
- You hear a snap when banging one log against the other
- The bark comes off easily
- There are cracks from the centre to the edge

HARDWOOD OR SOFTWOOD

The harder a wood is, the more heat it will produce and the slower it will burn (at equivalent moisture content).

Softwood can be used as kindling over hardwood. It burns more quickly (at equivalent moisture content) despite its lower calorific value.

- **Hardwood:** oak, beech, elm, ash, acacia, hornbeam, maple
- **Fruit tree wood:** walnut, cherry, pear, apple, olive
- **Softwood:** poplar, birch, linden., locust, chestnut
- **Resinous wood:** maritime pine, spruce, Scots pine, fir, larch

WOOD TYPES

Ash and beech are recommended as firewood as they dry quickly and are easy to find. They must be stored under a shelter immediately after being cut and split, otherwise they rot very quickly and lose their calorific value. They are easy to light and produce very bright, lively flames.

Maple has a good calorific value. It produces fires and embers that last a long time.

Oak is an excellent fuel, but unlike other wood species, it has to remain uncovered for two years to allow the rain to remove the tannins it contains. Then it has to be stored under shelter for another year or two before it can be burned. Small oak branches have a high sapwood content, which burns too quickly. Oak burns slowly, produces a calm fire and beautiful embers. It is ideal for barbecuing and for moderate fires.

Hornbeam, cherry and fruit trees are excellent fuels, but are rare. These are hardwoods. They produce beautiful, harmonious and calm flames, and beautiful embers. Ideal for a barbecue or a calm fire.

Birch, linden, chestnut, poplar and black locust are broad-leaved trees with soft wood. They produce beautiful, harmonious, but bright flames and few embers. Because they burn quickly, they can be used to start (or restart) the fire. Caution: Poplar produces abundant and volatile ash while black locust produces significant sparks.

Resinous woods generate a lot of heat, but they burn quickly. They throw sparks and the resins they contain cause build-up in the chimney.

CALORIFIC VALUE

Each type of wood has a different calorific value and all burn in different ways.

We strongly encourage the use of **hardwoods** such as hornbeam, maple, oak, ash, elm and beech. They produce beautiful flames and plenty of embers that glow for a long time.

**! CAUTION - NOT TO BE USED**

Burn only firewood. Do not burn:

- Garbage
- Lawn clippings, garden waste or unseasoned wood
- Materials containing plastic, petroleum-based products, gasoline, liquid fuel or rubber, including tires
- Waste petroleum products, paints or paint thinners, or asphalt products
- Industrial solvents
- Flammable liquids such as motor oil
- Painted wood, varnished wood or chemically treated wood
- Materials containing asbestos
- Construction or demolition debris
- Salt water driftwood or other previously salt-water saturated materials
- Railroad ties or pressure-treated wood
- Manure or animal remains
- Paper products, cardboard, plywood, or particleboard. The prohibition against burning these materials does not prohibit the use of fire starters made from paper, cardboard, saw dust, wax and similar substances for the purpose of starting a fire in this unit
- Any substance that emits dense fumes and strong odours

The heat produced by these materials is too great and can damage the appliance, in addition to causing soot to form on the glass pane and on the inside of the chimney pipe. These materials produce toxic and polluting fumes, such as carbon monoxide, which can be hazardous to health. Burning these materials may result in release of toxic fumes or render the heater ineffective and cause smoke.

Composite logs (ecological): Composite/ecological logs are to be avoided. They sometimes emit residues that sully the mechanisms and cause the appliance to age poorly.

Stûv appliances are designed for domestic use and must never be used to incinerate garbage of any kind.



! CAUTION

Read the safety instructions on pages 5 and 6 before using your fireplace. Upon first use, some smoke or odours may be produced. **Ventilate the room well.**

Never leave the fireplace handle on the unit or in front of the glass during use, the handle will get hot and may cause burns.

Do not stir or agitate the wood when it is burning.

! In case of a chimney fire

1. Call the fire department
2. Put out the fire with a type A or ABC extinguisher (powder, foam or water and additive) Avoid using a bucket of water or any other hazardous method to put it out.
3. Air out the room in which the unit is located.
4. After a chimney fire, have it cleaned and inspected by a professional.
5. Make the necessary repairs before using it again.

If the outside temperature is higher than the inside temperature, load more paper and more kindling to properly heat the chimney flue and thus counter the temperature unbalance. First ignite paper balls in addition to 700 to 1,000 g of kindling no bigger than $\pm 4\text{cm}^2$ of cross-section.

The maximum load to prevent overheating is 2x the weight of the hourly consumption. Refer to the table on page 6.

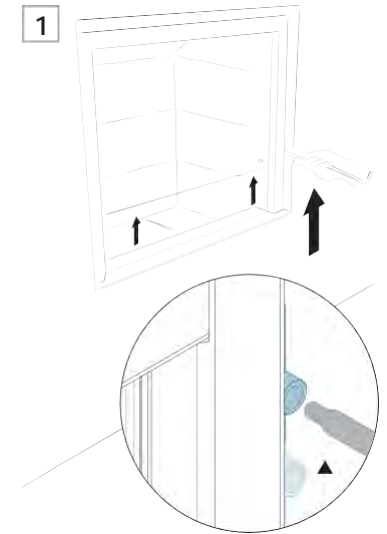

Step 1 Using the fireplace handle provided with the unit, slide the glass up.

Step 2 Place the wood logs in the combustion chamber using the inverted lighting technique as shown for a better combustion.

Step 3 Light the fire.

! ATTENTION

It is recommended to use fire starters made from sawdust or wood fiber, without chemical and toxic additives. Paraffin or other waxy substances can block the air supply system.

Step 4 Leave the glass door ajar by about 5mm for a minimum of 20 minutes. This helps create a better draft when starting the fire and prevents smoke condensation and soot deposits.

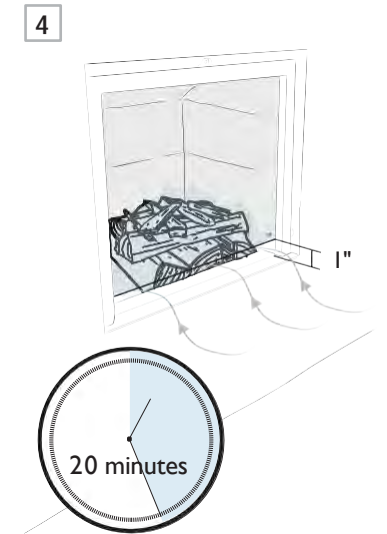
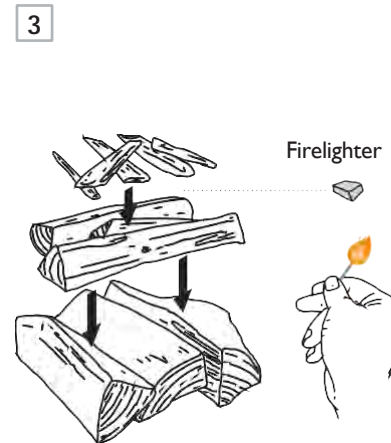
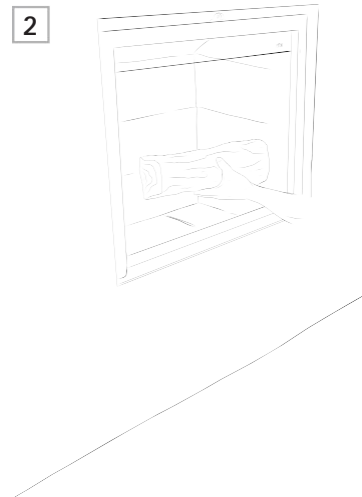

6.4 RELOADING THE FIRE



Step 1 Slowly slide the glass upwards to prevent a back draft.

Step 2 Add wood using the Stûv glove supplied with the unit.

Step 3 Close the glass door and enjoy the fire.*

*It is normal to feel resistance when lifting the glass door when the fire is burning.



6.5 ASH REMOVAL

Step 1 Wait until the ashes are cold before removing them from the combustion chamber.

Step 2 Use an ash shovel to remove ash. Place the ashes in a metal bucket.

Step 3 Place the bucket filled with ashes on a non-combustible floor. Be sure to keep the bucket away from any combustible material.

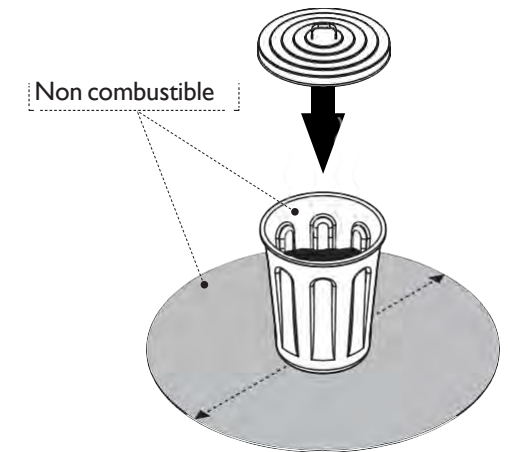
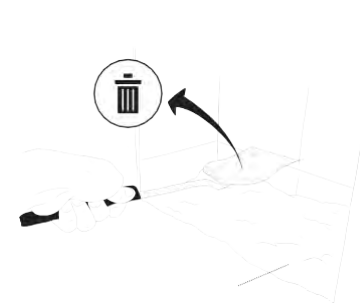
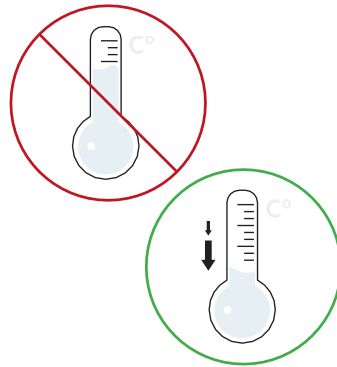

NOTE
Before they can be disposed of, ashes should be kept in a **non combustible bucket with a tight lid** until they have cooled completely. Remove the ashes regularly. Burning ashes can damage the lower glass door seal. This deterioration is not covered by the warranty.

7

MAINTENANCE

1.	REGULAR MAINTENANCE	55
2.	ANNUAL MAINTENANCE.....	56
3.	CREOSOTE AND CHIMNEY-SWEEPING	57
4.	PULLEYS AND COUNTERWEIGHTS	58
5.	COMPONENTS REPLACEMENT	59

7.1 REGULAR MAINTENANCE

1. During the heating season, have your chimney regularly inspected by a professional. Soot removal (sweeping) is recommended every two months to avoid creosote build-up.
2. Remove excess ash after each use. Do not wait for the ashes to overflow the fireplace. Excess ash can obstruct the supply of fresh air during combustion. Ash removal is explained in the *USE* section of this manual.
3. Cleaning the inside of the glass:
 - Tilt the door 90° using the fireplace handle.
 - Protect painted parts and flooring.
 - Finish with a non-abrasive glass cleaner or clear water. It is also possible to use ashes and water to effectively clean accumulated soot.

7.2 ANNUAL MAINTENANCE



! CAUTION

Before carrying out maintenance, wait until the unit has cooled down completely. The glass needs to be lowered completely in order to be able to tilt the door.

These four steps are described below.

- Vacuum the ashes from the joint section.
- Check condition of seals
- Lubricate the slides
- Clean the glass closing magnets

At least once every two years, remove and clean the smoke deflector to prevent soot from blocking the smoke outlet.

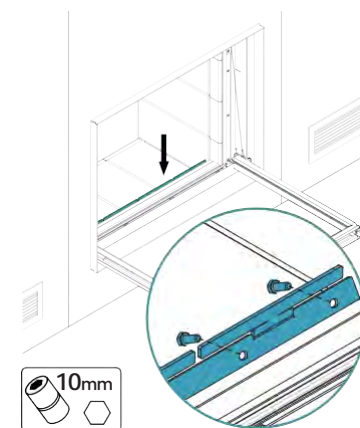

Step 1 Tilt the door forward.

Step 2 Vacuum any ashes that may have accumulated under the glass door in the joint section.

Step 3 Check the condition of the woven seal around the door perimeter and the lower silicone seal.

Contact a Stuv dealer in case of damage to the seals.

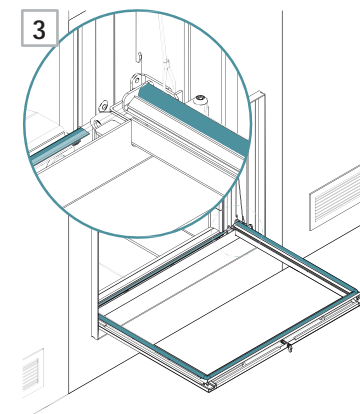
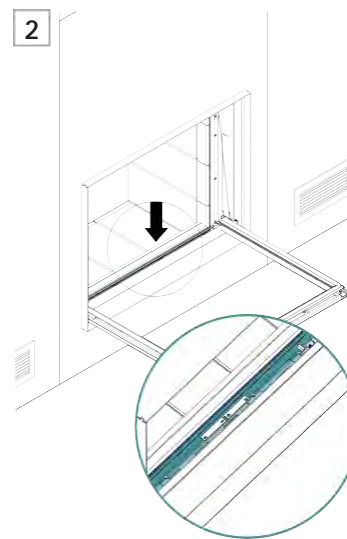
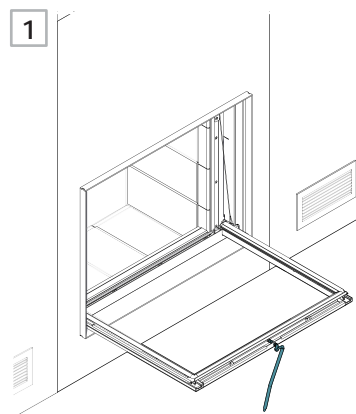

7.2 ANNUAL MAINTENANCE



Step 4 Place a support and/or a cloth to remove the door and avoid damaging the paint

Step 5 Unhook the cables from the door and attach them in *standby* mode.

! CAUTION

The cable must be held tight to make sure not to lose it!

Step 6 Slide the pane as far as it will go to gain access to the side rails.

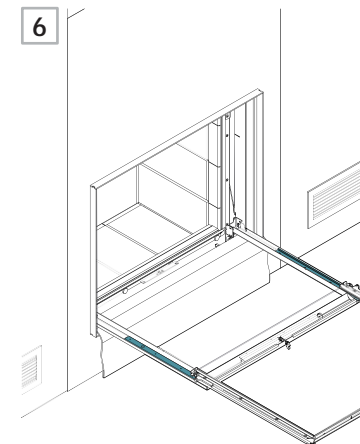
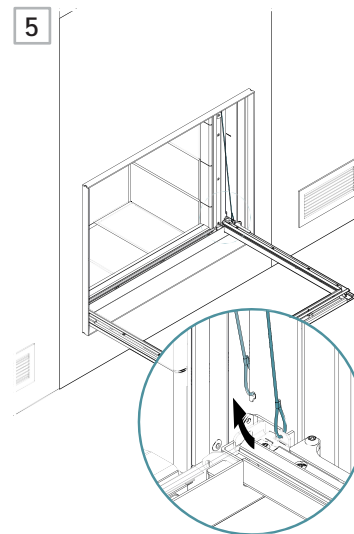
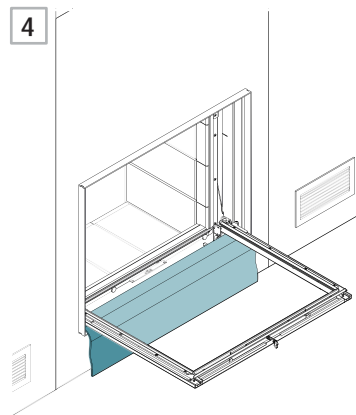

Step 7 Lubricate both sides (top and bottom) of both rails with the high-temperature lubricant (15 g tube - supplied with the fireplace).

Step 8 Slide the glass pane towards the fireplace and replace the 2 counterweight cables on the sliding parts.

Step 9 Slide the glass pane ± 4 cm and wipe the magnets with a cloth to remove any metal residue that may have stuck to them.

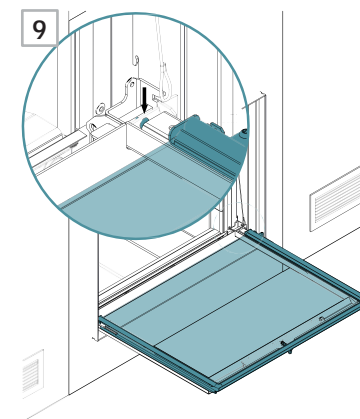
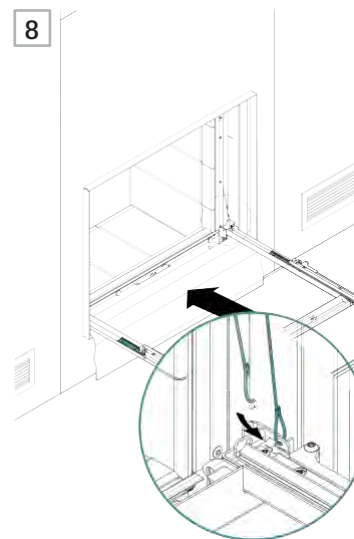
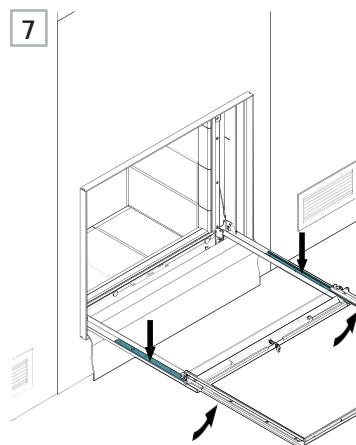

7.3 CREOSOTE AND CHIMNEY-SWEEPING

Creosote is a thick, black, brittle or smooth (vitrified) residue resulting from incomplete combustion of wood. During slow combustion, the wood releases tar droplets that condense on the cold chimney lining. The shape of the residue varies as a result of the time and the internal temperature of the lining on which the creosote vapors condenses.

This build-up of creosote can be very hazardous. When ignited, it produces an extremely hot fire in the chimney. Have your chimney professionally inspected every two months during the heating season to assess whether or not a creosote build-up has occurred. If so, remove any built-up residue to reduce the risk of a chimney fire.

Before carrying out a complete sweeping, Stûv recommends using a dose of Fulgurant (a product that decomposes soot) to thoroughly clean the glass of the appliance. Use a product compatible with the type of chimney flue installed. Refer to product instructions for use during maintenance.

Soot Removal Steps - Before doing the maintenance, wait until the unit has cooled down completely.

1. If sweeping is done from the inside, slide the glass upwards.
2. Remove the top vermiculites supported by the baffle kit.
3. If sweeping is done from above, lower the glass door by pressing down on the cylinder grip.
4. Carry out the sweeping according to local regulations.

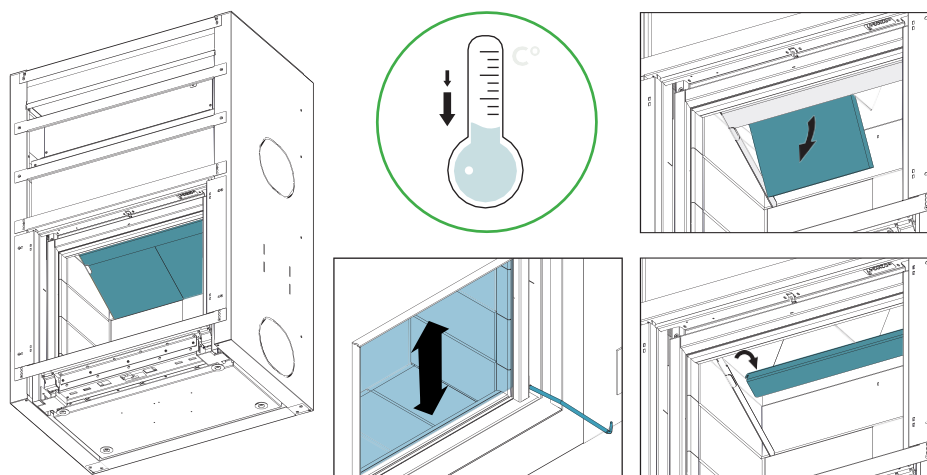

7.4 PULLEYS AND COUNTERWEIGHTS



The Stûv 21 range of fireplaces is equipped with a guillotine door that works with a system of pulleys and counterweights. The basic principle is quite simple:

1. A steel wire is attached to a hook at the bottom of the glass frame.
2. The cable is then placed on a pulley fixed on the top of the unit.
3. The second end of the wire hooks onto a free counterweight located on the sides of the fireplace.
4. When you lift the handle located at the bottom right or left of the glass, an upward movement brings the counterweight down, giving you access to the fireplace hearth.

For details on how to operate and reinstall the cable of the pulleys, see section **INSTALLATION** on page 33.

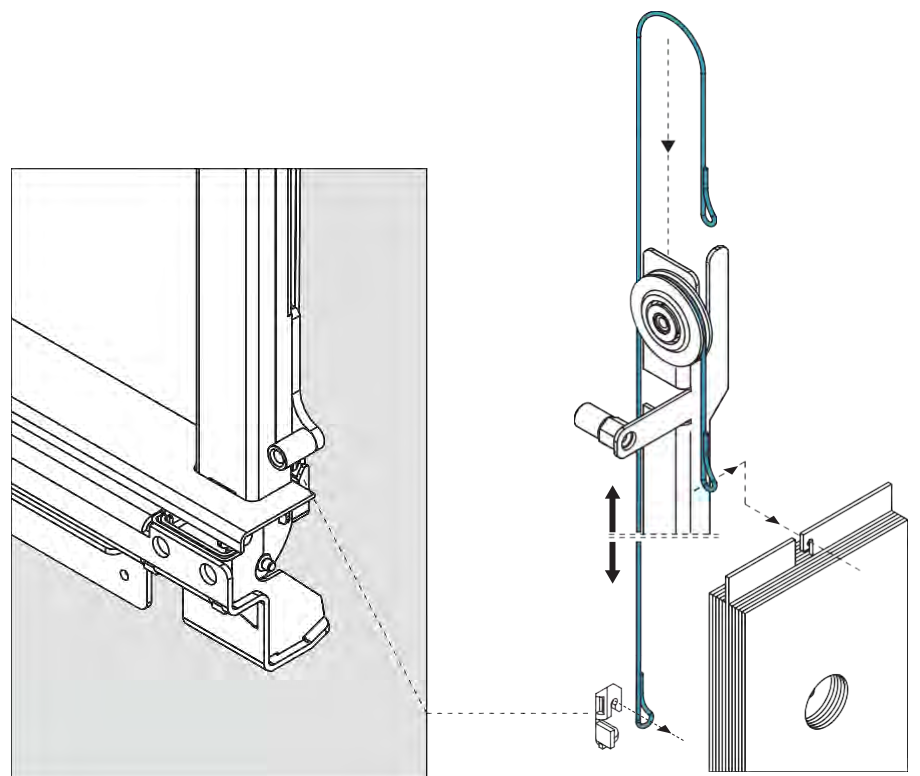



DISASSEMBLY

Step 1 Using the fireplace handle open the glass door and tilt it open like an oven. It is recommended to use some kind of support on which the door will rest to avoid damage.

Step 2 Use rags to make sure the paint is protected

Step 3 Carefully unhook the counterweight cables in both bottom corners and attach them to the hooks made for this purpose on each side of the unit.

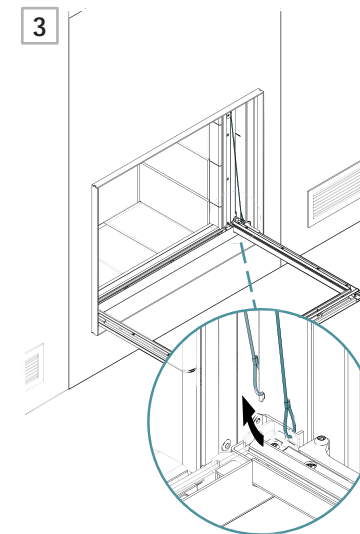
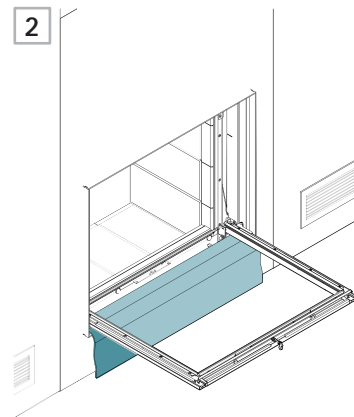
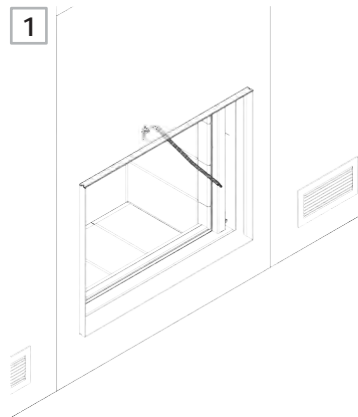

DOOR SEAL

Step 4 Tilt the door 20° up, lightly slide up approx 2". Remove the two small Philips head screws from the frame holding the seal located at the center of the glass frame.

Step 5 Using a flathead screwdriver pry the hooks on the bottom of the seal to release the rest of the seal/metal rod at the bottom of the glass on the frame. You will be able to lift the seal and rod out from those hooks.

Step 6 Going from front to back remove the seal from the frame, starting from the extremities slide it off the underwire.

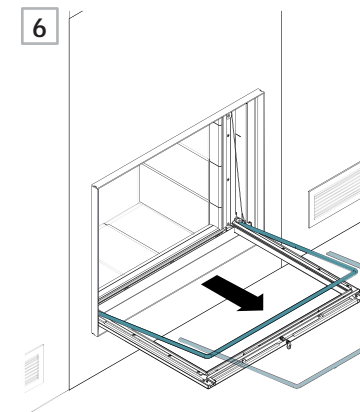
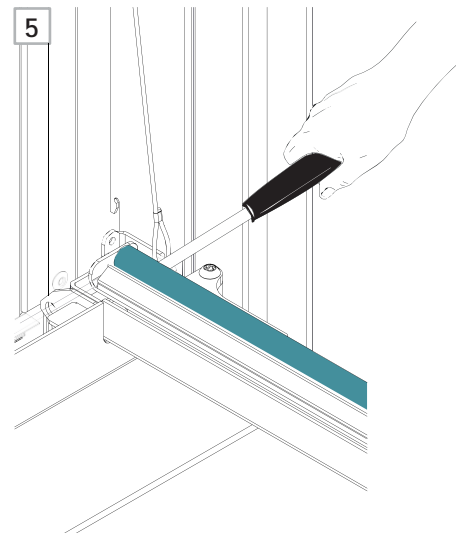
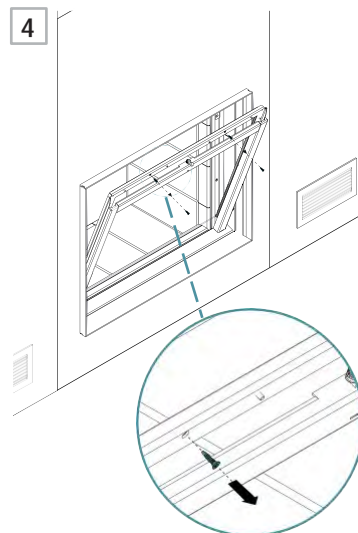

7.5 COMPONENTS REPLACEMENT



Step 7 Find the side of the frame that has 2 perforated flat sections, these need to be facing up towards the philips screw ports

Step 8 Slide the new seal onto the underwire make sure they are of equal length on both sides, leaving more clearance on the horizontal part.

Step 9 Insert the 2 frame extremities into the 2 orifices at the bottom of the door making sure the flat sections are facing up, insert the seal into the groove of the door.

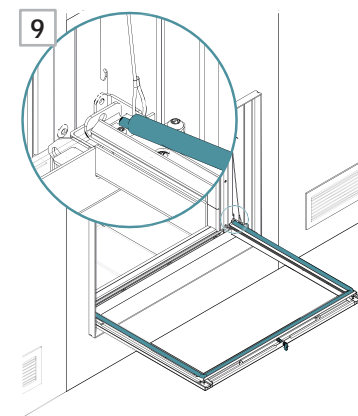
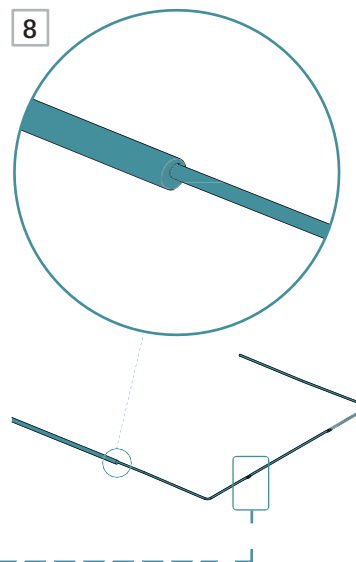
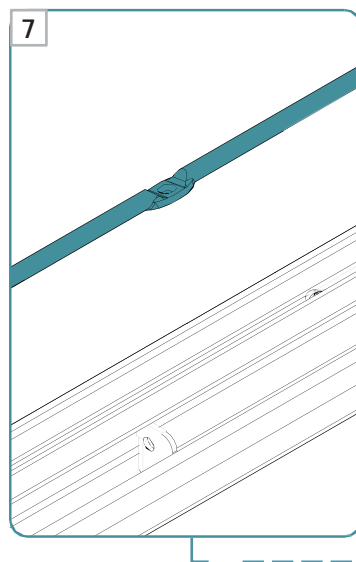

Step 10 Slightly lift the door (45°) and slide up the glass 100mm secure the frame by piercing the seal with the screw, do not tighten too much so the seal doesn't lift at all angles. Hand tighten is perfect.

Step 11 Make sure the screws went through the frame orifice by lightly squeezing the seal.

Step 12 Adjust the seal by stretching the extremities to the edge of the glass. Fold the pointed flap onto the seal by using a flathead screwdriver. Make sure the point enters well into the seal.

Proceed to reassemble (explained at the end of the chapter)

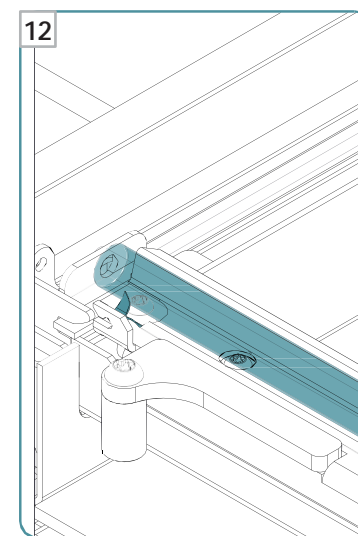
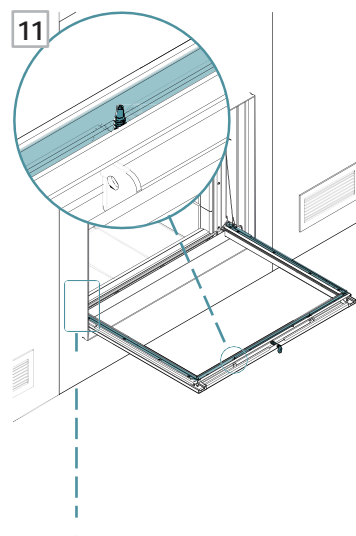
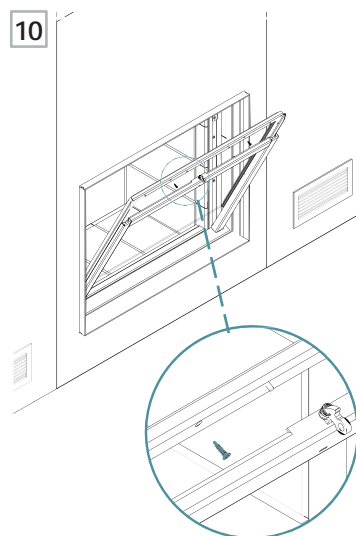



GLASS AND SLIDES

After disassembly, follow these steps:

Step 13 Using an 8 mm open-end wrench, unscrew the damper cover.

Step 14 Close the door and remove the damper panel cover.

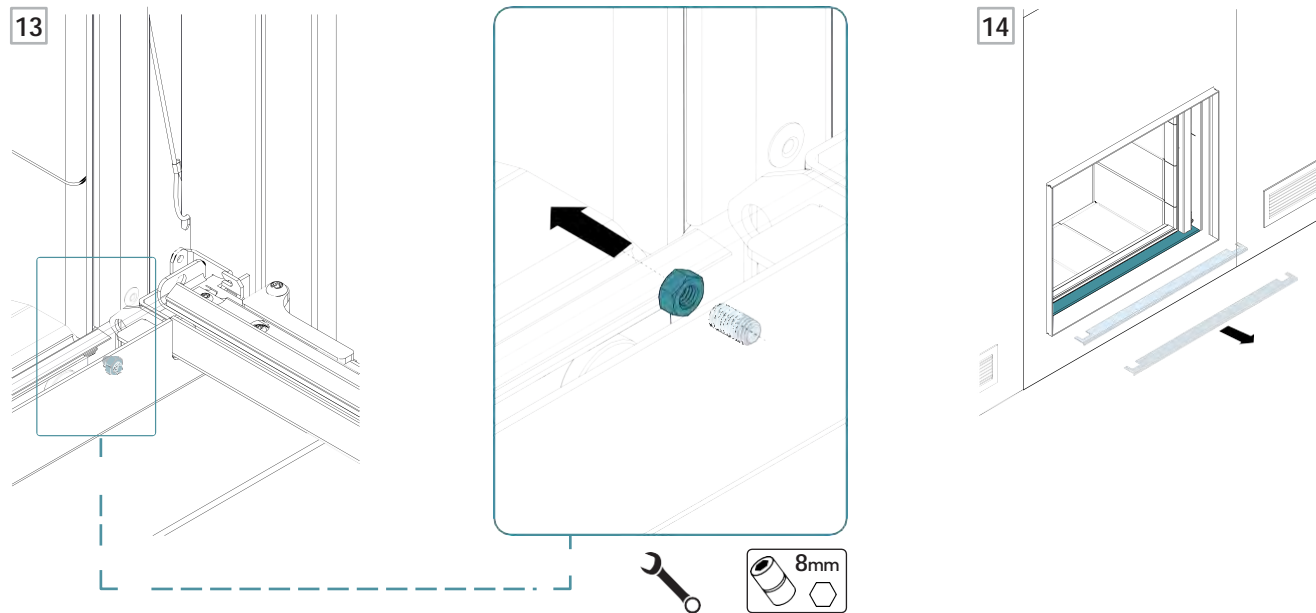

Step 15 Using the fireplace handle remove the keys freeing the innersprings. Put them on the left and right side.

Step 16 Unscrew and remove the glass pane.

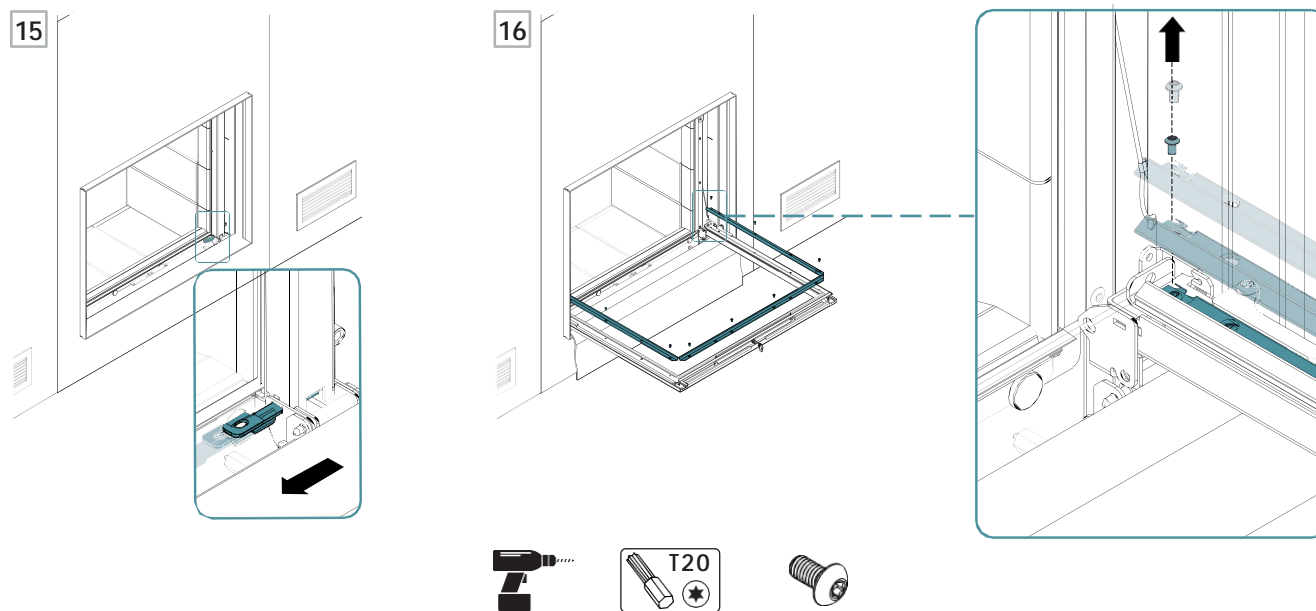

7.5 COMPONENTS REPLACEMENT



Step 17 Remove the (damaged) glass.

Stüv recommends the use of original replacement parts.

The glass must be made of 4 mm ceramic and be able to withstand high temperatures.

MODEL	DIMENSIONS
21-85	554 mm x 692 mm
21-95	634 mm x 790 mm
21-105	419 mm x 892 mm
21-125	554 mm x 1090 mm

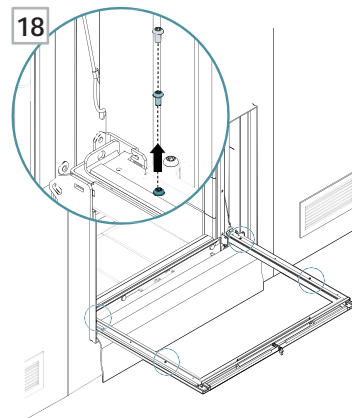
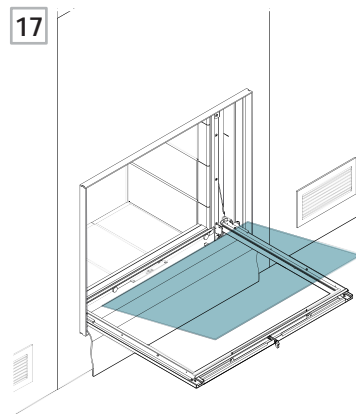

Step 18 Using a Torx 20 bit remove 2 screws from each side.



Step 19 Remove the sliding door.

Step 20 Move the center rail of the slide to access the four screws, then unscrew.

Step 21 Remove the (damaged) slide.

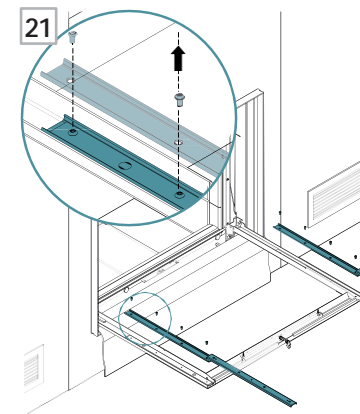
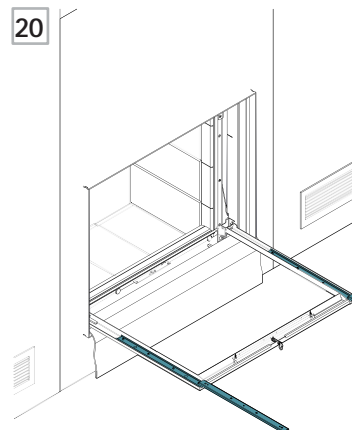
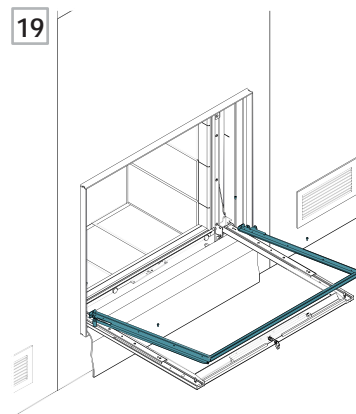



REASSEMBLY

To reassemble, proceed in reverse order. Centre the spacer.

Step 22 Screw the slide back in place using the 2 screws on each side of the sliding door frame. Make sure all seven holes are facing upwards (they must be visible).

Step 23 Place the glass. Verify that the Stûv logo is vertical in the bottom right hand corner.

Step 24 Replace the glass pane

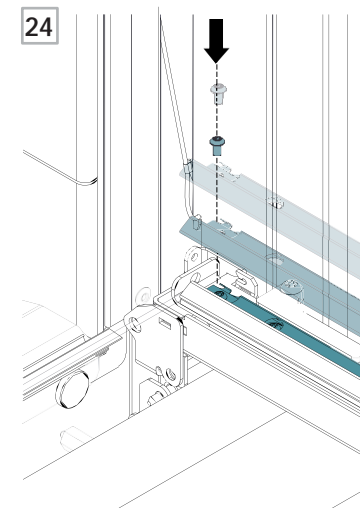
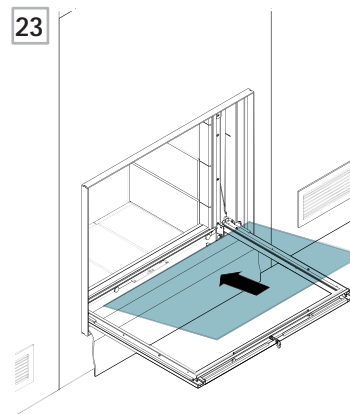
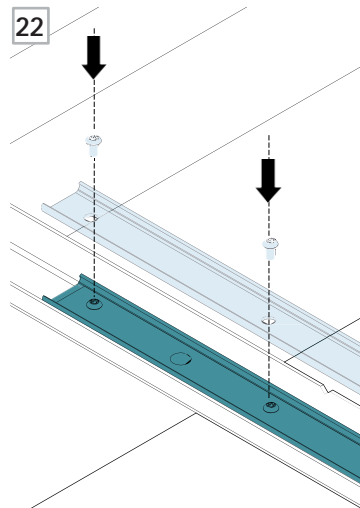

Step 25 Attach the counterweight cables to the glass door.



CAUTION

Careful not to let these cables go when reattaching.

Step 26 Close the door and put back the innersprings, put back the nut.

Step 27 Put back the damper cover panel.

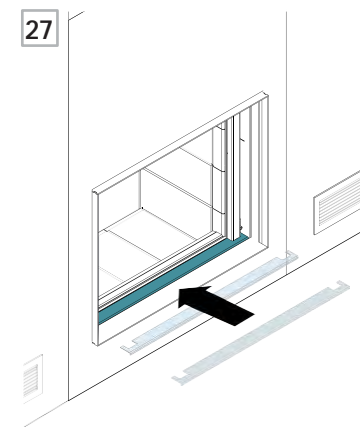
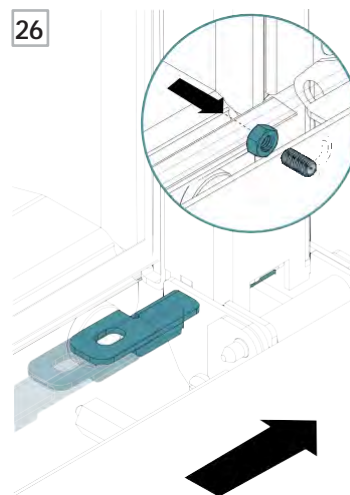
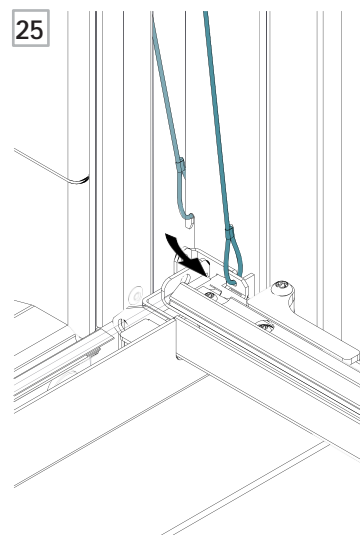

8

WARRANTY

1.	WARRANTY DETAILS	64
2.	WARRANTY FORM	65

7.1 WARRANTY DETAILS



WARRANTY COVERAGE

Stûv appliances are guaranteed against:

- manufacturing defects
- paint defects on the visible parts of the unit
- glass breakage, but only if it occurs during the first firing
- shipping-related damage if we are notified within 48 hours of delivery and the damage is noted on the carrier's bill of lading when the unit is received (website)

This warranty does not cover damage to the appliance or malfunctions due to:

- installation that does not comply with the applicable regulations or the installation instructions
- abnormal use that does not comply with the directions for use
- lack of maintenance
- an external cause, such as a flood, lightning strike, fire, etc.

The warranty is limited to replacing the parts deemed defective and does not include labour or damages.

WARRANTY TERMS

This document must be returned to us, duly completed, within one month of the date of the dealer's invoice to the buyer.

Duration of the warranty:

- 5 years on the body of the appliance
- 1 year on refractory materials, gaskets, door mechanism, hinges and latches.

The warranty period begins on the date of the dealer's invoice to the buyer. The replacement of parts under warranty does not extend the duration of the initial warranty.

When an item is defective, it is important to quickly notify an authorized Stûv dealer. They will contact The Fireplace to fill out the warranty form. They will need:

- the unit's serial number
- the date the unit was purchased
- an explanation of the defective item
- photos of the defective item

With this information, Stûv America will be able to validate whether the part is covered by the warranty and judge the relevance of changing it. The dealer will also be in charge of installing the new part.

CERTIFICATE OF WARRANTY

This Stûv appliance has been designed to offer you maximum pleasure, comfort and safety. It has been manufactured with the utmost care using quality materials and components to provide years of trouble-free operation.

Should you notice a defect in spite of this care, we commit to rectifying the situation. However, as a user, you also have an important role to play in getting the satisfaction you expect from your Stûv.

We strongly recommend:

- having the unit installed by a qualified professional who can ensure that the installation of the appliance and the integrity of the chimney are in compliance with the certifications and the building code,
- carefully reading the operating and maintenance instructions,
- having the chimney swept regularly (once per heating season, for regular use) to ensure optimal operation and maximum safety.

7.2 APPLIANCE DETAILS



THE APPLIANCE

Serial no.: _____

Model: _____

Invoice date : _____

Installation date : _____

*The serial number can be found on the marking label at the bottom of the combustion chamber. The location of the label is indicated on the first page of the *CERTIFICATION* section..

THE INSTALLER

I, the undersigned,
declare that the above-mentioned appliance has been installed in compliance with the existing regulations and in accordance with the technical recommendations in the installation instructions.

Date: _____

Signature: _____

Company: _____

Name: _____

Address: _____

Tel no.: _____

THE DEALER

Company: _____

Name: _____

Address : _____

Tel no.: _____

THE BUYER

Name: _____

Address : _____

Email : _____

Tel no.: _____

Installation address (if different) : _____

PLEASE FILL OUT ONLINE WARRANTY FORM :

Our website: thefireplace.co.nz

Contact: technical@thefireplace.co.nz





Stûv fireplaces are designed and
manufactured by :

Stûv sa – Belgique
stuv.com

Rue Jules Borbouse n°4 B-5170
Bois-de-Villers

And distributed in New Zealand by :

The Fireplace Ltd

12 Tawari St, Mt Eden, Auckland,
1024

Ph. 09 623 6990

The Fireplace

Stûv 21 | October 2023