







Stovax Studio 2 Rural Inbuilt Fire with Edge+

Minimalist design, stunning elegance.

The Stovax Studio range balances presence with efficiency and heating performance. A selection from this peerless range of contemporary fires will add gravity and style to any interior. It represents the pinnacle of British fire design, engineering and technical innovation.

A rapid start-up 'boost mode' makes it easy to ignite logs. Whether you want a lazy flame, or a vivid roar, your Studio 2 rural model will give you full control over your fire thanks to its innovative easy-to-use single air control, requiring only light operation for responsive instant adjustment.

Key Features

-  Architecturally inspired design
-  Landscape viewing window
-  Warm air room ducting
-  Boost control for easy lighting
-  Optional sealed external air kit

NOTE: This rural model is suitable only for installations into homes on properties 2ha or larger.

The Fireplace Ltd reserves the right to change all content contained herein and subject to change without notice.

Product Specifications

(All dimensions in millimetres)

Firebox Model #	RVST-2HTUK
Average Heat Output	15kW
Fuel Source	Wood
Weight	153kg

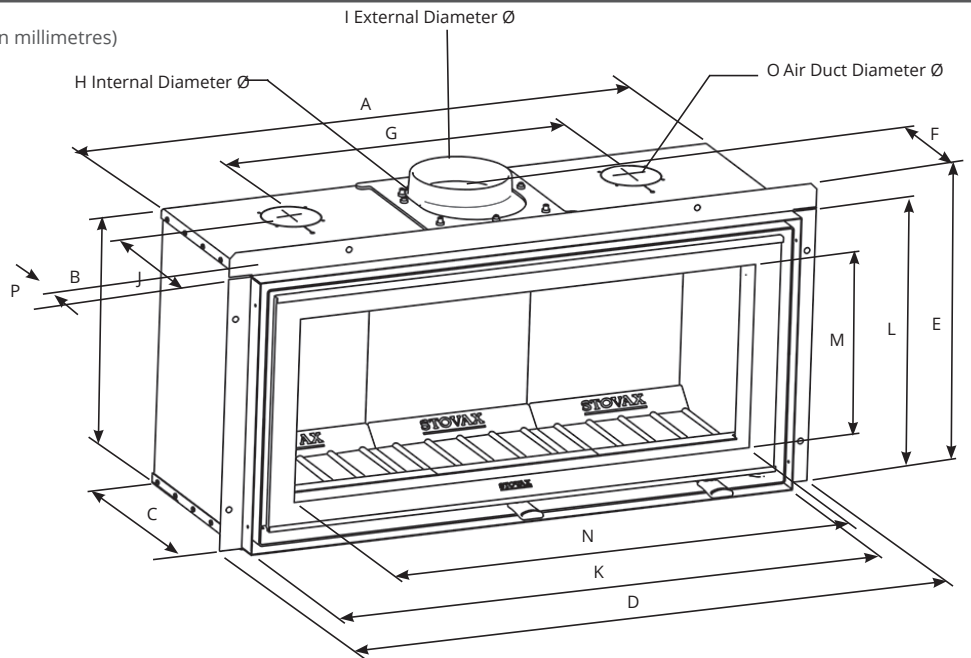

Product Dimensions

Description	A	B	C	D	E	F	G	H	I	J	K	L	M	N	O	P
Studio 2	983	476	348	1055	518	244	611	152	171	240	979	476	284	790	100	40

Installation Information

IMPORTANT: PLEASE REFER TO COMPREHENSIVE INSTALLATION INSTRUCTIONS PRIOR TO CONSTRUCTION AND INSTALLATION
 DOWNLOAD FROM: www.thefireplace.co.nz

Minimum Timber Frameout Dimensions

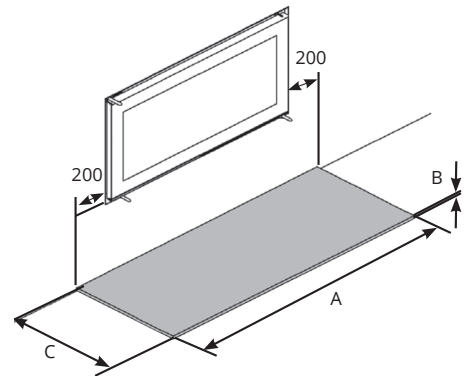
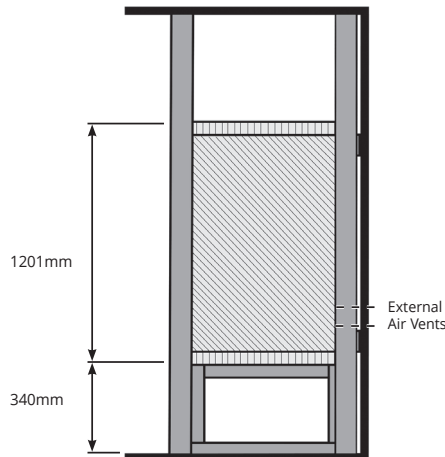
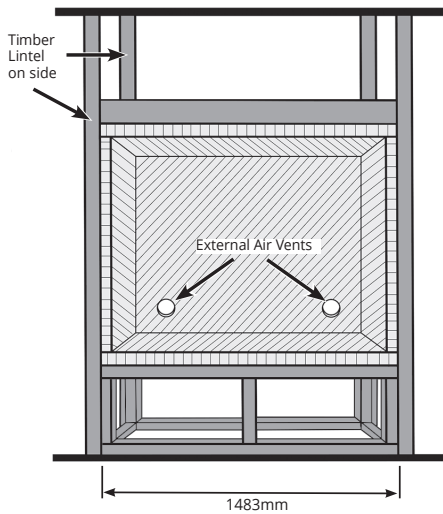

Floor Protector Minimum Dimensions

Floor Protector (mm)	A	B	C
	1350	20	670

Options & Accessories



Stovax Studio 2 Rural Inbuilt Fire with Profil

FRAME OPTIONS

- Edge + frame for minimal finish
- Profil metallic black frame

OTHER ACCESSORIES

- External sealed air kit
- Reverse door hanging kit

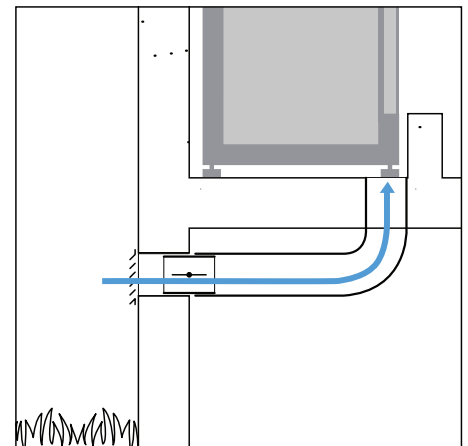

Exclusive New Zealand Distributor

The Fireplace Ltd

12 Tawari Street, Mt Eden
 Auckland 1024, New Zealand

Ph: 09 623 6990

Email: sales@thefireplace.co.nz
www.thefireplace.co.nz

Your Local Retailer