



**Firenze  
Woodfires**

# Topaz LEB/RU

**Installation and Operation Guide**

**LEB Authorisation #212341**



**Please read this booklet and keep for future reference  
for the safe installation and operation of your Topaz Fire**

This Fire must be installed by someone competent to do so, Firenze recommend the use of a NZ Home Heating Association, solid fuel Fire installation technician (SFAIT), or other suitably qualified person. The Fire and Flue System must be installed in accordance with AS/NZS2918. All Installations must be in accordance with these instructions. Consult with the building authority having jurisdiction to determine the need for a permit prior to commencing the installation. Failure to follow these instructions may also void your fire insurance and warranty.

This Fire has been tested to Appendix E & B of the joint Australia/New Zealand standard 2918:2001.

# Contents

1. Warnings .....	2
2. Operating Instructions .....	3
3. Maintenance .....	6
4. Installation Responsibilities .....	8
5. General Information .....	9
6. Masonry Installation .....	18
7. Built-In Fire Canopy Installation.....	26
8. Topaz Lowline .....	36
9. Warranty .....	37

# 1. Warnings

**This Fire should always be maintained and operated in accordance with these instructions.**

The Topaz LEB/RU is tested to N.Z. Standards AS/NZS 2918:2001.

If this Fire is incorrectly installed a house fire may result.

For your safety follow the installation instructions carefully.

Do NOT connect the Fire to a chimney serving another Fire.

Although the exterior of the Fire may appear cool, contact with the Fire may cause burns.

Warn children and others of the possibility of injury should they touch the Fire.

Do NOT dry clothing or unseasoned wood directly in contact with the Fire.

Keep all household combustible materials at least 600mm away from front of the Fire.

This includes clothing, furniture, wood, newspaper, plastic, matches, etc.

**Do not use FLAMMABLE LIQUIDS or AEROSOLS in the vicinity of this Fire when it is operating.**

Use caution when reloading with fuel.

Do NOT attempt to load fuel into the Fire when the fire inside the stove is at or near its peak.

Do NOT burn large quantities of paper or combustible material that create an extremely quick fire.

Do NOT burn highly coloured paper or brochures (e.g. junk mail).

**Use only dry wood (25% or less moisture content). AVOID BURNING WET OR GREEN WOOD.**

**The use of preservative treated wood as a fuel can be hazardous.**

Timber treated with copper chromium and arsenic type preservatives will leave toxic residues in the ash, firebox or within the flue, timber offcuts from building construction will often contain boric salts. The combustion of this material over prolonged periods can produce adverse effects on refractory lining in solid fuel Fires. Emission of poisonous gases can also be experienced with the burning of treated wood.

Driftwood with salt content will also cause rapid deterioration of the Fire and should not be used.

## 2. Operating Instructions

**Please read fully before proceeding any further. Keep this book in a safe place.**

### SAFETY

All surfaces of the fire will get hot and cause burning if touched by bare hands.

Firenzo recommends using a fireguard.

The heat from the fire will effectively dry laundry and other wet articles; however such materials should be kept well clear of the Fire to prevent accidental fires.

The Flue should be cleaned regularly to avoid flue fires. In such event, close the air control.

**Do NOT the open door.**

Remove combustible items from near the Fire and Flue.

### FIRST BURN

On the initial lighting only, the high temperature paint finishes used on your Fire will give off smoke and odour for several hours. As this is a temporary condition, open doors, windows, etc. to give adequate ventilation until passed.

Prepare fire by placing crumpled paper in the middle of the firebox.

Do not use a grate or elevate fire. Build fire directly on the floor of firebox.

Pull air control knob out fully for high setting. (This is the small knob to the right of the door)

**Air Control Out = High**

**Air Control In = Low**

Arrange dry kindling in “tepee” style with larger pieces standing up on each side.

Ignite paper leaving door ajar until kindling is alight.

When vigorous flaming of the kindling subsides and embers begin to appear, reload with larger wood, placing them in a side to side configuration.

Open door carefully and place small pieces, then larger logs on top.

Close door tight and leave Air Control on High for approximately 30 minutes.

The value in establishing this technique is that you are providing an excellent base for burning your wood effectively. When a good fire is established move air control to middle position.

**Do not immediately shut the fire to Low.**

Remember to close the air control gradually to your desired level of heat output.

It is better to take 3-4 adjustments to get to the Low setting (extended burn).

## RELOADING

Move the Air Control to High before opening the door.

Never open the door when a vigorous fire is in progress. Wait until the flames have subsided and the wood has broken up into glowing embers. Reload with dry logs, placing them in a side to side configuration

Leave the air control in the High position for 10 to 15 minutes or until the flames begin to subside. This shows that the initial highly volatile wood gases have been driven off and the Fire will be able to maintain an even burning rate.

Normally a light load of fuel will stabilize quickly but a full load will take longer. Once the burning rate has stabilized move the Air Control to a medium position.

## RE-LOADING AFTER AN EXTENDED BURN TIME

At the end of an extended burn, re-establish the fire by adding a few small split logs, adjust the Air Control to High and allow the firebox temperature to build up before adding the balance of the fuel, loading logs in a side-to-side configuration.

The addition of large quantities of cold fuel to a low fire will reduce the firebox temperature dramatically and this may result in 'losing' the fire.

Proceed with the fire as before.

**Do not operate the Fire with the door constantly open,** this overrides the Air Control System and greatly lowers the optimum heat output and efficiency.

## FUEL

Dry, seasoned softwood should always be used, with a moisture content of less than 25%.

The heat output level on the Fire is controlled not only by the Air Control but also by the type and quantity of fuel in the firebox.

A fully loaded firebox set to High will produce far more heat than an almost empty Fire set at the same position. Remember, you only get out of any Fire what you put into it. The better the fuel, the better the Fire.

**Do NOT burn plastic, household refuse or driftwood.**

**This will void any Warranty and reduce the lifespan of the fire.**

## FLAMMABLE LIQUIDS

### **CAUTION**

**Never use gasoline, kerosene, charcoal lighter fuel or similar liquids to start or 'freshen-up' a fire.**

### CLEANING THE ASHES FROM THE FIRE

Ashes should be placed in a metal container with a tight-fitting lid. The closed container of ashes should be placed on a non-combustible floor or on the ground, well away from all combustible materials, pending final disposal. If the ashes are disposed of by burial in soil or otherwise locally dispersed, they should be retained in the closed container until all cinders have thoroughly cooled.

A layer of ash at least 25mm deep should always be left in the bottom of the firebox - it will also act as insulation for the fire.

### **WARNING**

**Do not remove excess ash from the firebox by vacuum unless the fire has been out for 5 or more days - embers will smoulder for several days and will ignite vacuum cleaner bags.**

## 3. Maintenance

### FLUE

Creosote is caused by burning wet fuel, leaving particles and condensation to build up on the inside of any closed solid fuel Fire. Creosote and soot left to build up can cause decreased heat performance and flue fires. Your heating retailer or local reputable chimney sweep will be able to assist with flue cleaning.

### SECONDARY CHAMBER

The baffles (horizontal bricks in the ceiling of firebox) are critical to the Fire's performance and should be checked annually during flue cleaning and replaced if signs of deterioration are evident.

### DOOR HANDLE AND HINGES

Light lubrication is recommended once a year before the first autumn burn. Use a little graphite grease available from most hardware stores.

### FIRE BRICKS

The internal fire bricks on the sides and base of the firebox can crack in extreme heat; they are safe to leave as is until they start to crumble in which case they should be replaced.

### FIRE ROPE

The door rope and glass tape should be checked regularly and replaced as part of general maintenance.

### WELDS

The 5mm exposed steel sill and deflector in the fire box is welded on each side but primarily to the firebox underneath. With expansion and contraction, the side welds develop hairline cracks. Do not be alarmed as the main weld is sound and the Fire will not be affected in any way. Any hairline cracks are not a structural problem.

### INTERNAL DISCOLOURATION

A brown (rust like) colouration will develop on the exposed inside of the fire box. This is expected over time and does not affect the performance of the fire.

## DOOR GLASS

This Fire is equipped with a self-cleaning glass air wash system.

Discolouration can appear on the glass after a long low burn; 30 minutes of high burn should clear the glass. If necessary, you can clean the glass with wet newspaper dipped in ash from the firebox.

**Do NOT clean glass when it is still hot.**

### **CAUTION**

**This fire should not be operated with a cracked glass.**

If replacement glass is required, **it must be replaced with Firenzo Ceramic Glass.**

The insulating material for the glass should be replaced at the same time.

**Never place glass directly against the door.** Without the insulation seal tape in place, the glass is likely to shatter. Your Firenzo Dealer will be able to supply any spare parts.



## 4. Installation Responsibilities

This Fire must be installed by someone competent to do so. Firenzo recommend the use of a NZ Home Heating Association, solid fuel Fire installation technician (SFAIT), or other suitably qualified person. Consult with the building authority having jurisdiction to determine the need for a permit prior to commencing the installation. Failure to follow these instructions may also void your fire insurance and warranty.

This Fire has been tested to Appendix E & B of the joint Australia/New Zealand standard 2918:2001.

**WARNING: The Fire and Flue System must be installed in accordance with AS/NZS 2918:2001 Appendix F and the appropriate requirements of the relevant building code or codes. Firenzo/SFP Flue Kits or Davin Flue Kits must be used.**

**CAUTION: Mixing of Fire or Flue System components from different sources, modifying the dimensional specifications of components, or using more than 1 metre of extra flue may result in hazardous conditions. Where such action is considered the manufacturer should be consulted in the first instance.**

The Fire must be installed with a minimum flue length of 4.2m.

Any modification of the Fire that has not been approved in writing by the testing authority is in breach of the approval granted for compliance with AS/NZS 4013.

Before installing your Firenzo Topaz it is important to check the condition of your masonry chimney. Ensure any cracks are sealed, loose masonry repaired, and the chimney swept.

Check that the dimensions of your fireplace opening are adequate to accept the new Fire. Existing linings may need to be removed.

The Fire must be installed on a level non-combustible base and fixed with seismic restraints through the anchor points at the front feet of the unit.

**CAUTION: This Fire has a total weight of over 100kg. Installers must use their lifting and handling equipment to prevent injury when handling the Fire.**

**Strict adherence to these instructions will meet these standards. Any variation from these installation instructions or any doubt about them must be checked against the requirements of the standards.**

## 5. General Information

### Topaz Firebox Assembly

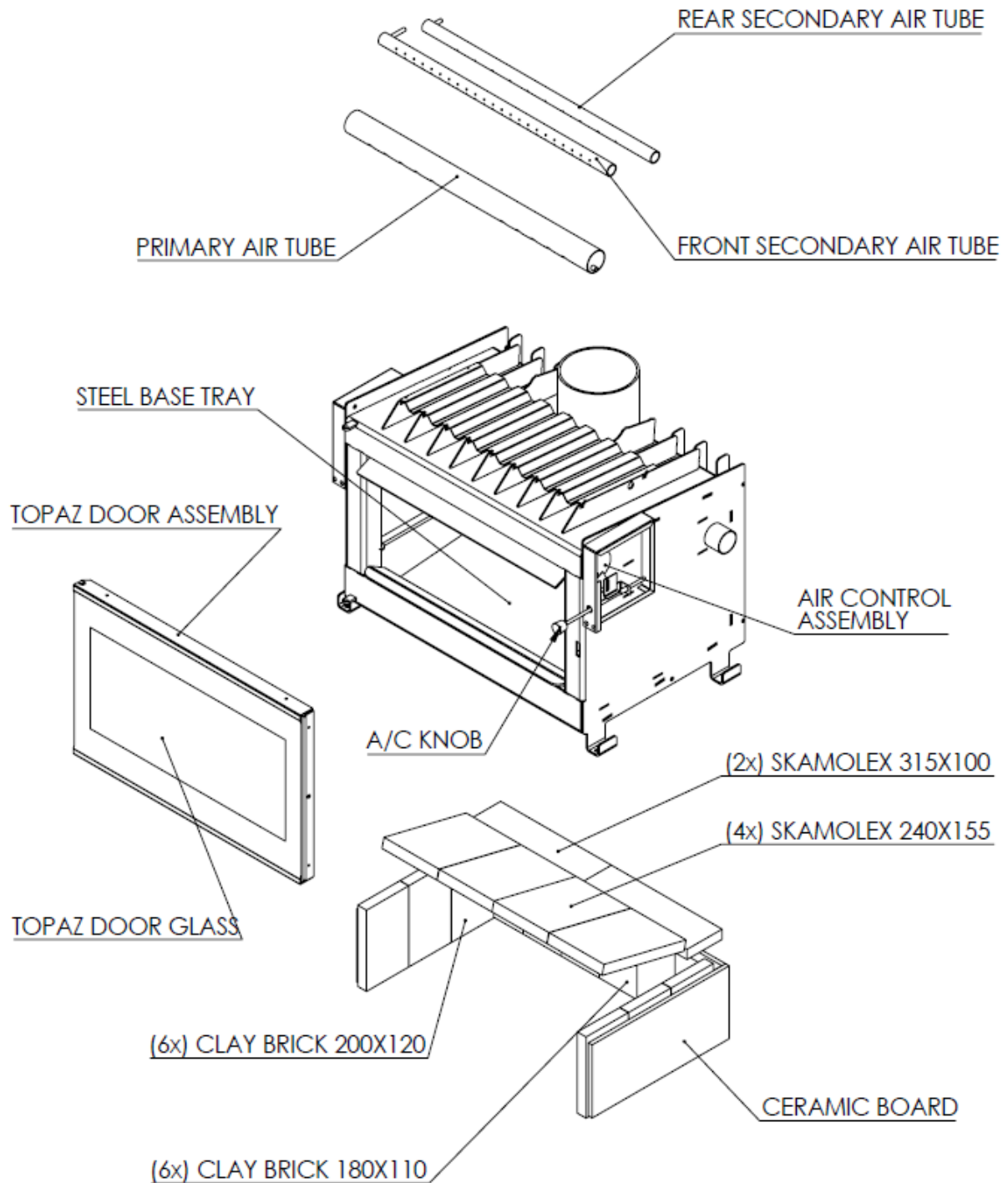

## Firebox Dimensions

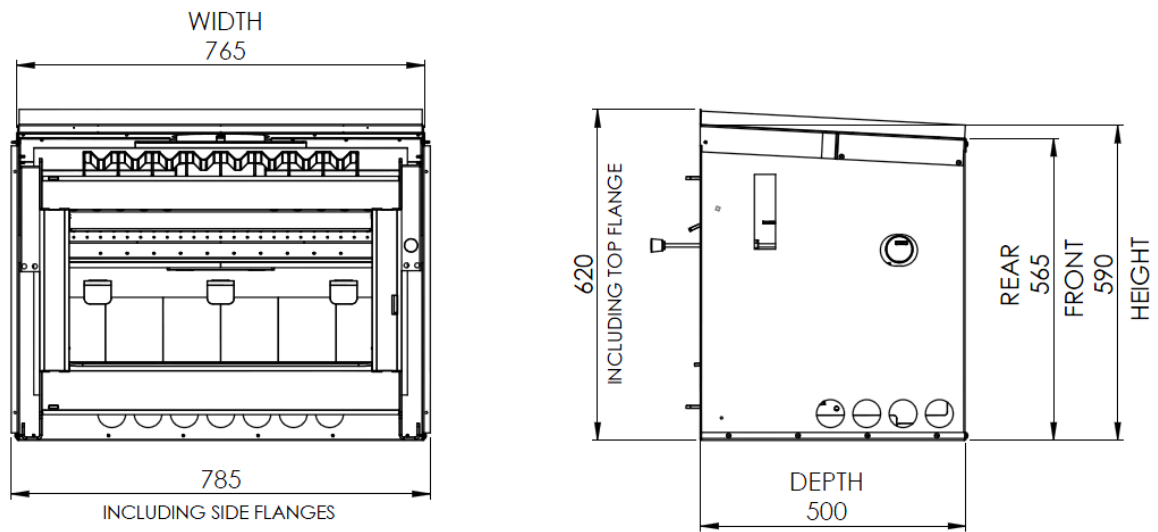

## Zero Clearance Box Dimensions (Built-In Canopy)

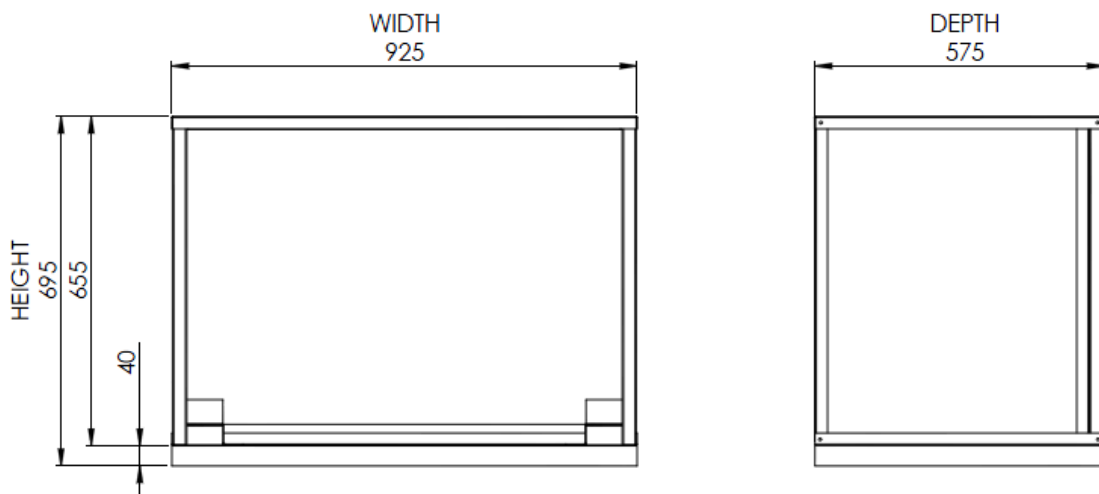

Note: the Zero Clearance Box includes a 40mm non-combustible base.

Internal Firebox Measurements: Height 260mm – Width 570mm – Depth 400mm

## Fascia Dimensions

### Standard Topaz Fascia

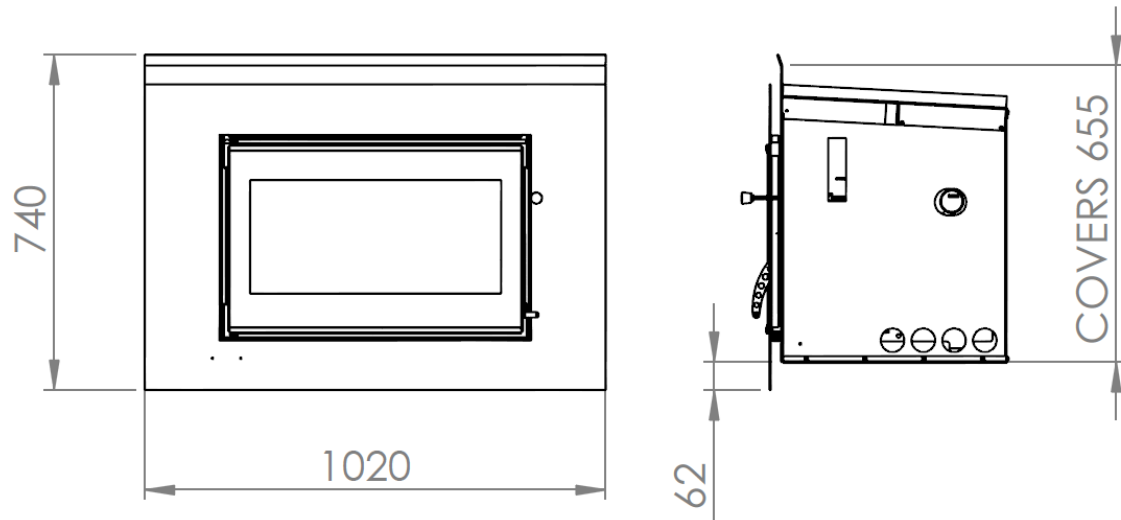

### Topaz Lowline Fascia

*for installation on a non-combustible hearth only*

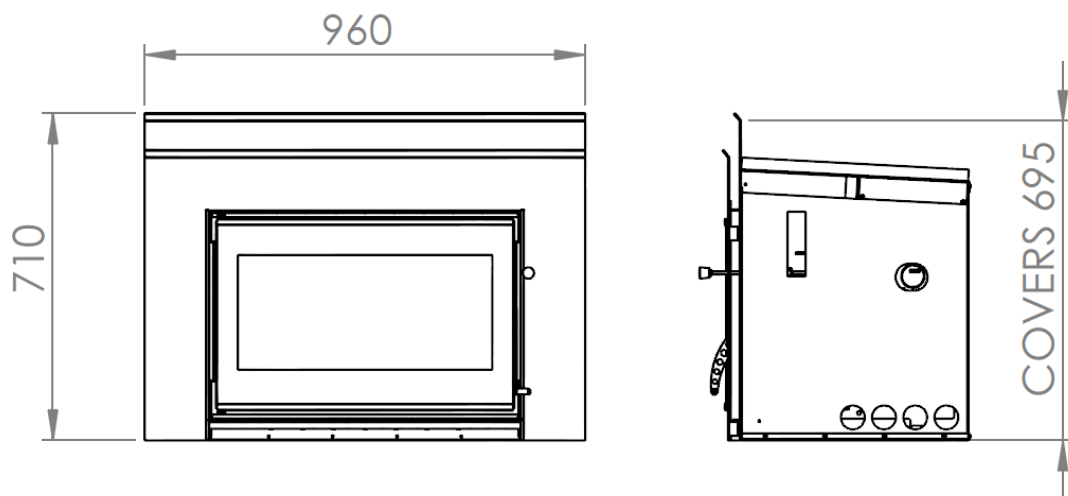

### Opening in a Masonry Installation

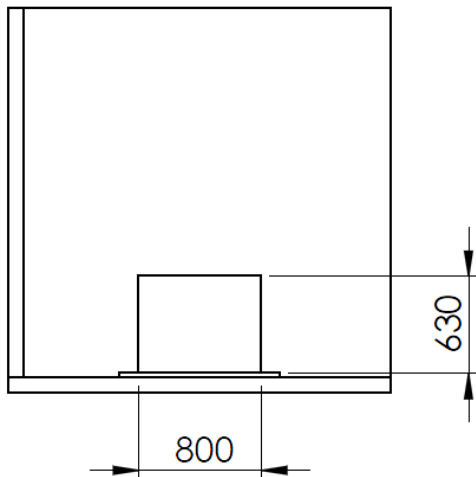

### Opening in a Zero Clearance Install

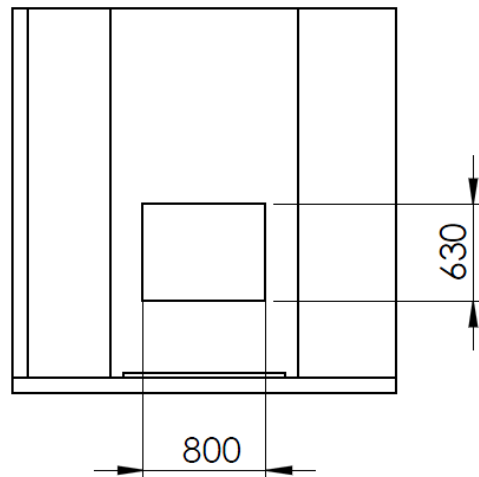

### Floor Protection Requirements

#### Hearth Installation

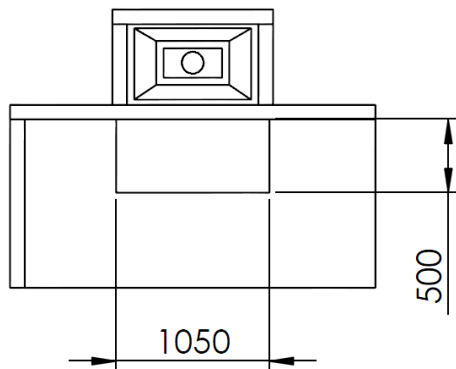

#### Elevated Installation

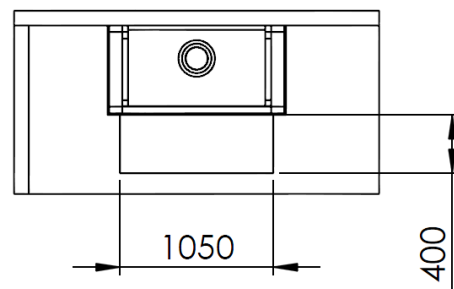

### Recommended Non-Combustible Wall Lining

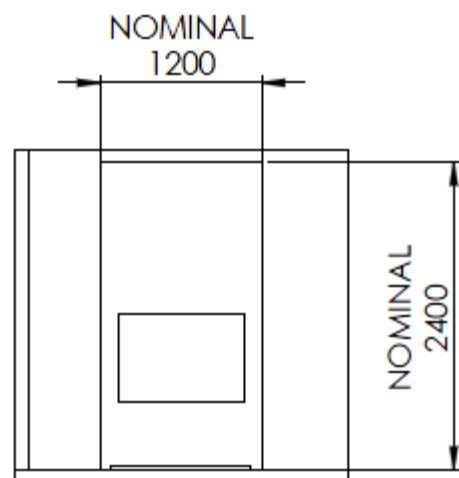
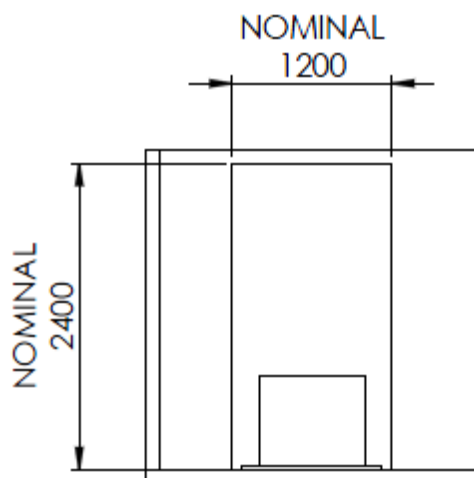

## 5A. Venting into Chimney

For both masonry and built-in-canopy (zero clearance) installations, adequate ventilation must be provided into the chimney. The air vent in the chimney must be a minimum area of 10,000mm<sup>2</sup> (100mmx100mm) and must meet the building code to prevent water ingress and vermin entering the chimney space.

## 5B. Clearance to Heat Sensitive Materials

**Do not use combustible mantels (e.g. wood) with the Topaz Fire.**

Only non-combustible mantels (e.g. steel or concrete) may be used.

The minimum clearance from the side of the fascia to any heat sensitive material must be 5mm, providing the material does not protrude more than 150mm.

## 5C. Floor Protection Requirements

AS/NZ2918 Section 3.3 states that if the Fire is to be placed on or within 500mm of heat sensitive materials in the floor then a floor protector will be required.

The floor protector shall extend under the Fire and not less than 400mm beyond the front of the fuel loading or ash removal openings. **Where the fire is installed flush with the hearth using the 'Topaz Lowline Fascia' the minimum distance increases to 500mm.**

The width of the floor protector must extend not less than 200mm from each side of the fuel loading or ash removal openings unless it forms an abutment with a wall or heatshield at a lesser distance.

For the Topaz In-built Fire, the minimum width of the floor protector is 1050mm and/or 525mm about the centre of the Fire.

When installing the standard Topaz fascia, the base of the Topaz firebox must be no less than 120mm above the floor to allow sufficient airflow into the canopy for convective heating.

The top of the Topaz firebox must be no less than 1200mm below the ceiling.

## Floor Protection Requirements for a Solid Concrete Floor in a Masonry or Zero-Clearance Installation

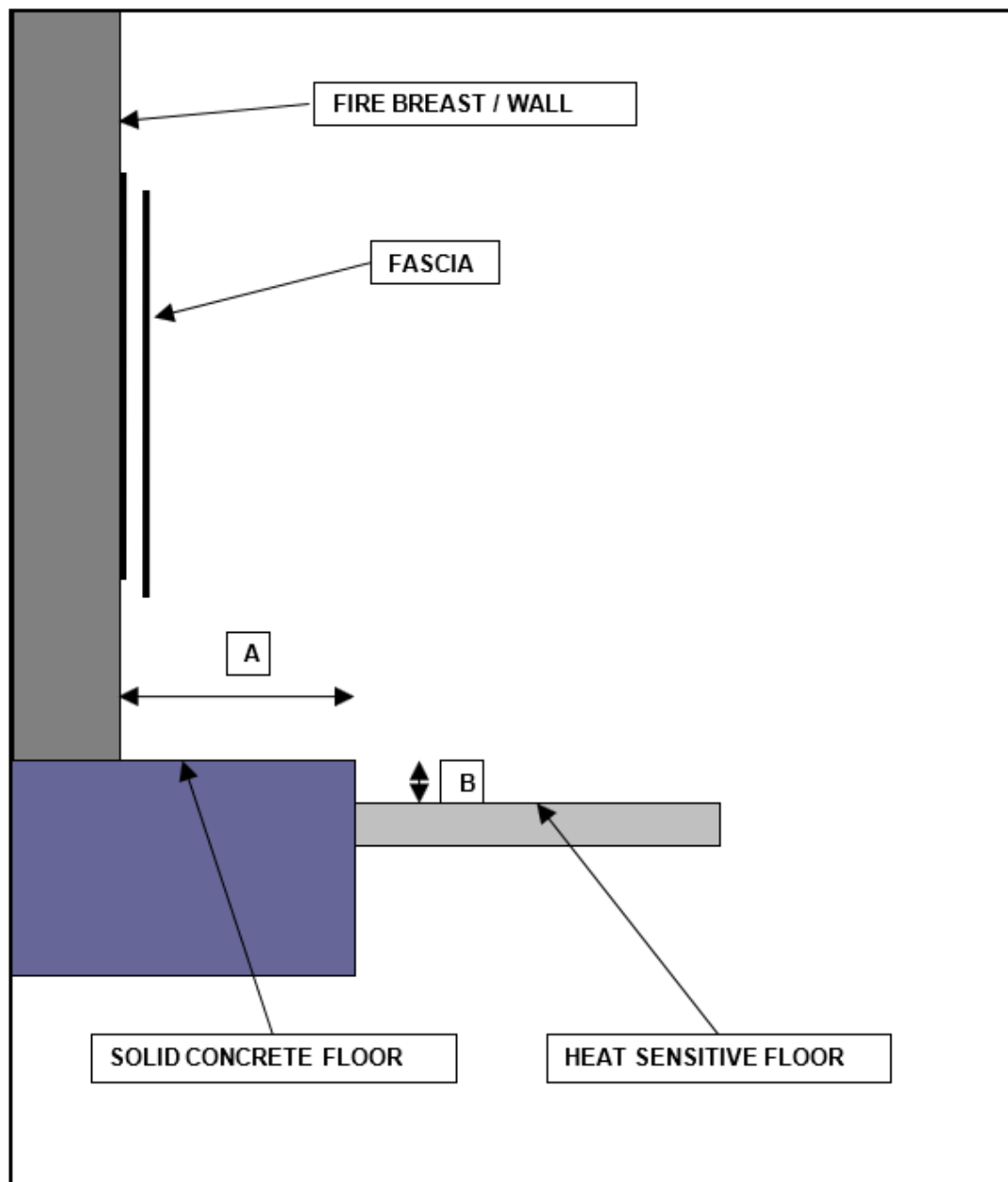

If the Fire is to be installed onto a solid concrete floor protector (hearth) that has no heat sensitive materials in its construction it must meet the following **minimum dimensions** as marked A & B from Diagram above:

**A** 400mm from breast of fire to outer edge of concrete floor protector (hearth)

**B** 30mm from heat sensitive floor to upper edge of concrete floor protector (hearth)

The **minimum width** of floor protector is 1050mm and/or 525mm from the centre of the Fire. The Fire must be installed a minimum of 120mm above the floor to allow sufficient airflow.

**Note** Where the fire is installed flush with the hearth using the 'Topaz Lowline Fascia' the minimum distance 'A' increases to **500mm**.

## Floor Protector Requirements for Heat Sensitive Floors in a Masonry or Zero-Clearance Installation

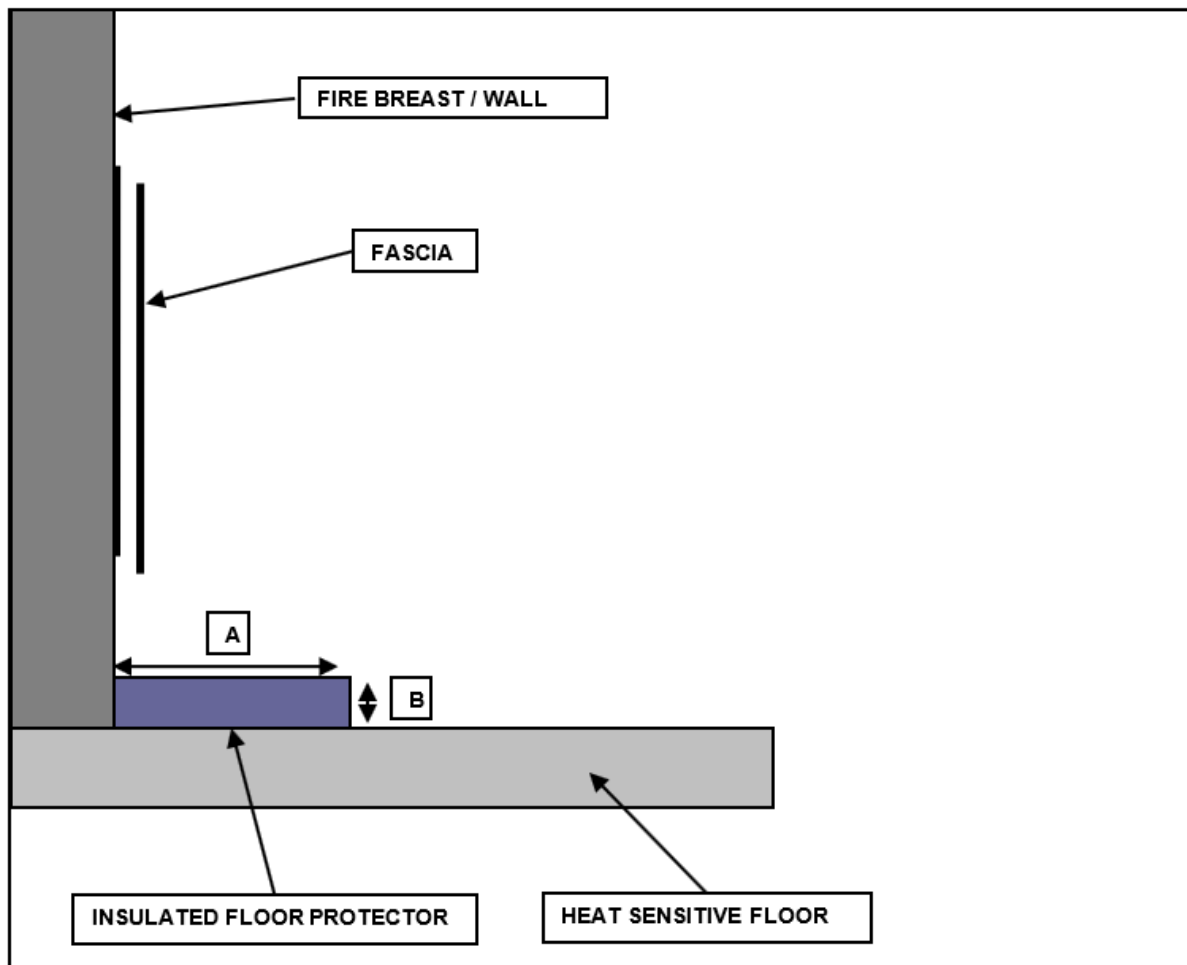

If the Fire is to be installed above a heat sensitive floor it must have an insulated floor protector of the **minimum dimensions** as marked A & B in the diagram above:

**A** 400mm from breast of fire to outer edge of the insulated floor protector (hearth)

**B** 30mm from heat sensitive floor to upper edge of the insulated floor protector (hearth)

An Insulated Floor Protector (Hearth) must consist of a minimum of 20mm of Insulation board (Promatech H, Eterpan LD, Pacbld-Pro or product of similar thermal resistance) and tiles/slate or similar with sealed joints on top surface to protect from spilt ash/embers.

The **minimum width** of floor protector is 1050mm and/or 525mm from the centre of the Fire.

The Fire must be installed a minimum of 120mm above the floor to allow sufficient airflow.

**Note** Where the fire is installed flush with the hearth using the 'Topaz Lowline Fascia' the minimum distance 'A' increases to **500mm**.



## Floor Protection Requirements for a Zero-Clearance Installation

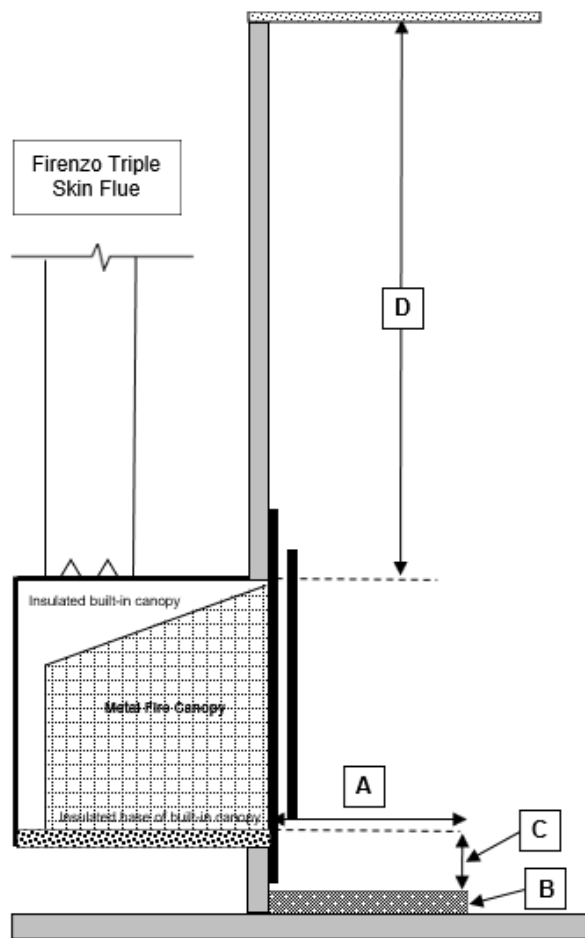

Position	Distance (mm)	Note
A	400	Minimum distance from the front of the firebox to the edge of the insulated floor protector.
B	30	Minimum height of the insulated floor protector.
C	120	Minimum distance from the floor protector to the bottom of the metal canopy of the fire.
D	1200	Minimum distance from the top of metal fire canopy to the ceiling.

### IMPORTANT:

9.5mm Heat Resistant Cladding (Promatech H, Eterpan LD, Pacbld-Pro) is stipulated in this installation guide as the cladding to use in non-masonry situations. The wall cladding temperature can get hot to the touch and it is recommended that advice is sought from a reputable paint manufacturer regarding the type of wall paint used.

The Topaz Fire requires an insulated floor protector to AS/NZS 2918:2001. The floor protector must consist of a continuous durable no-combustible upper surface and be at least 30mm above any heat-sensitive flooring.

An Insulated Floor Protector (Hearth) must consist of a minimum of 20mm of Insulation board (Promatech H, Eterpan LD, Pacbld-Pro or product of similar thermal resistance) and tiles/slate or similar with sealed joints on top surface to protect from spilt ash/embers. The insulated floor protector **must extend a minimum of 400mm** from the firebox. The **minimum width** of the insulated floor protector is 1050mm and/or 525mm from the centre of the Fire.

The Fire must be installed a minimum of 120mm above the floor to allow airflow under the fascia.

The top of the fire canopy must be no less than 1200mm from the ceiling above.

**Note** Where the fire is installed flush with the hearth using the 'Topaz Lowline Fascia' the minimum distance 'A' increases to **500mm**.

## 5D. Flue Height Requirements

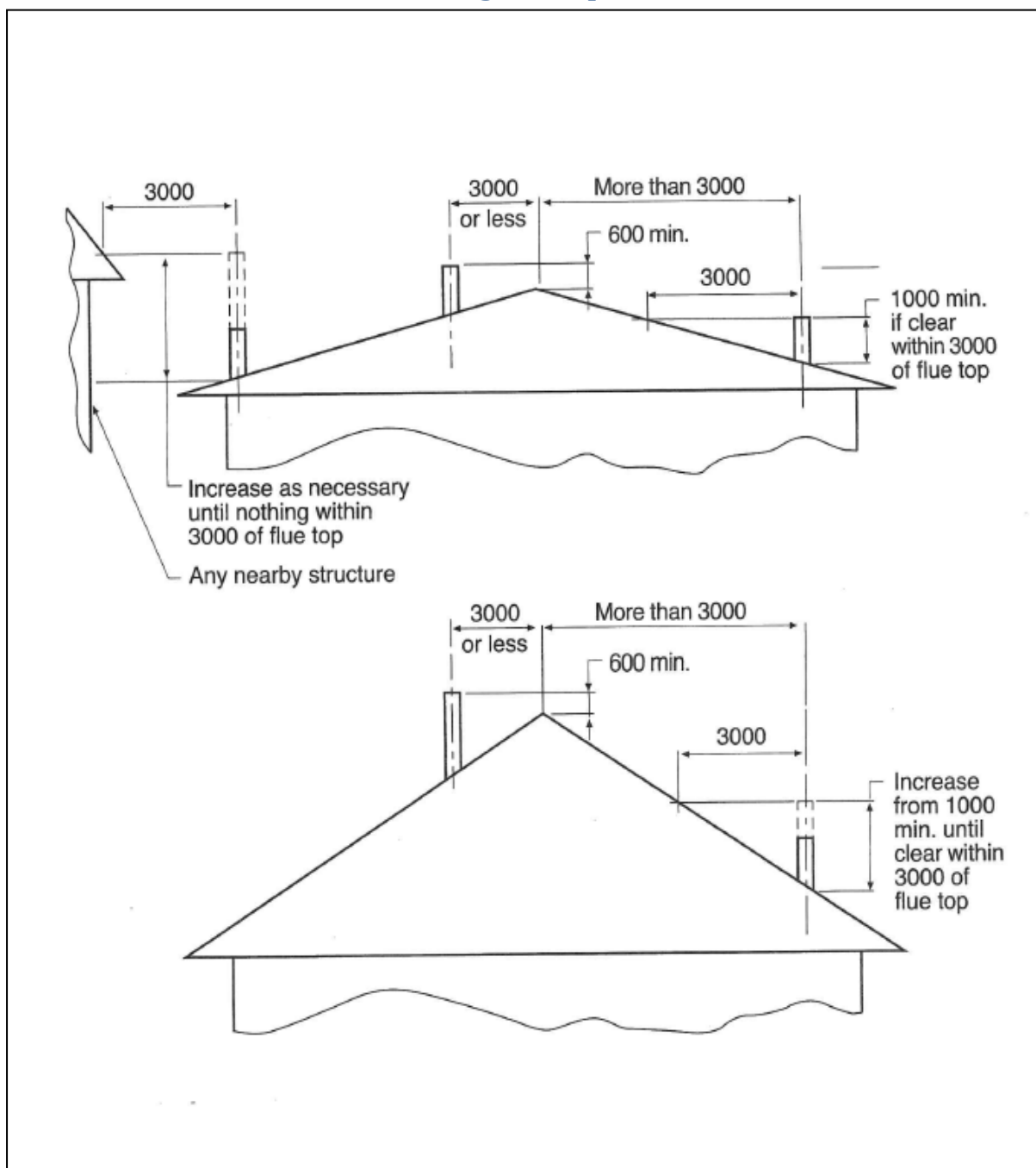

### NOTES

The Fire must be installed with a minimum flue length of 4.2m. If the flue is to be extended by more than 1 metre, the Manufacturer must first be consulted.

The flue cowl must be at least 600mm above the highest point of the roof if within 3 metres of it, or 1 metre above the roof penetration if more than 3 metres from the ridge.

No part of the building, or any adjacent building may be in or above a circular area of a horizontal radius of 3 metres from the flue exit.

## 6. Masonry Installation

The following pages outline the installation of the Topaz Fire in an existing masonry chimney.

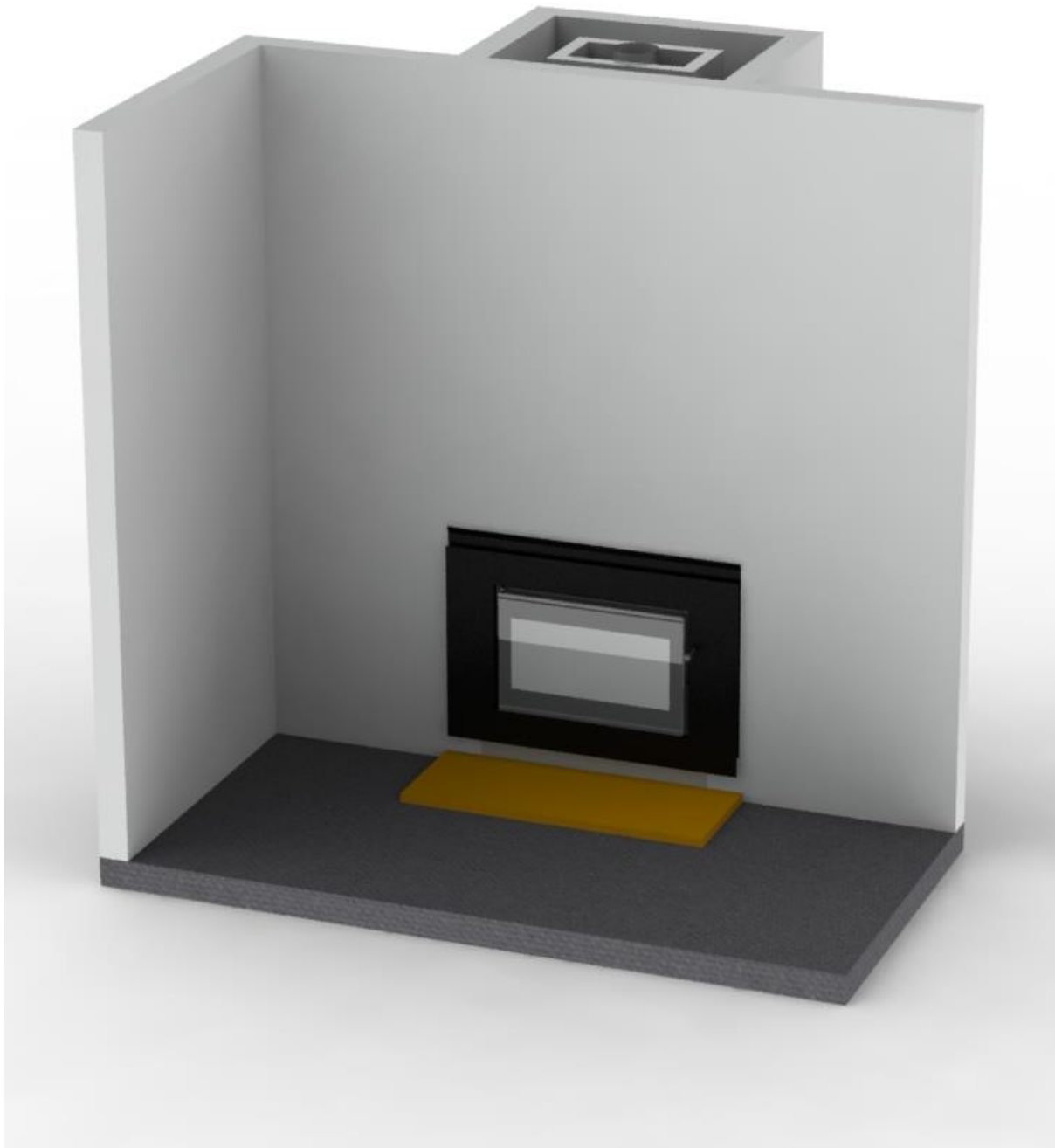

## 6A. Assembly Instructions

- 1) Carefully remove all packaging.
- 2) Slide the Firebox into the opening so that the outer casing return folds are flush with the finished fireplace surround.
- 3) It is important to anchor the fire box down in case of movement. Restraint points are provided through the fire's two front legs.
- 4) Install Flue as per instructions on page 19.
- 5) Fill any gaps between the steel canopy and the opening in the masonry chimney with the yellow ISB insulation provided. See note below.
- 6) Assemble and fit the fascia.

### NOTES

**In some circumstances you may have to alter the chimney to accommodate the Topaz Fire. This work must be done to the Building Code.**

**In the case of installing this Fire in existing masonry fireplaces, it is necessary to install additional ventilation into the chimney cavity as per AS/NZ 2918 3.4.1.2 to assist air flow into the fire. This ventilation should not be taken/drawn from the room that the fire is installed in. This air vent should measure 100mmx100mm or equivalent area.**

**As this fire sources its combustion air from the chimney cavity/enclosure, the fire must be sealed around the front between the steel canopy and the masonry fireplace. This is achieved by packing the yellow ISB insulation (supplied) between the steel canopy and the masonry at the front of the fireplace to a maximum depth of 80mm. Refer to page 21 for further detail.**

## 6B. Insert Flue System for a Masonry Installation

**WARNING:** The Fire and Flue System shall be installed in accordance with AS/NZS 2918:2001 Appendix F and the appropriate requirements of the relevant building code or codes. Firenzo/SFP Flue Kits or Davin Flue Kits must be used.

**CAUTION:** Mixing of Fire or Flue System components from different sources or modifying the dimensional specifications of components using more than 1 metre of extra flue may result in hazardous conditions. Where such action is considered the manufacturer should be consulted in the first instance.

Position the Fire in the fireplace.

Extend plumb line from the top of the chimney, ensuring fire spigot is in line with top of the chimney. If not, flue offsets will be required.

- 1) Assemble flue ensuring all seams are in line and assembly is straight and tight with crimped ends pointing downwards.
- 2) Secure flue with at least three stainless steel or monel rivets and seal.
- 3) Fasten chimney plate supplied onto the chimney top. The chimney plate must be weather sealed with silicone or mortar.
- 4) Install chimney liner over chimney plate.
- 5) Ensure flue is extended over the chimney liner by 180mm. Secure top spacer bracket to the flue and ensure slots fit snugly inside the chimney liner.
- 6) Slide flashing cone over top of flue until it rests firmly over the top spacer.  
Ensure ventilation gap is not closed off.  
Secure with pop rivets or self-tapping screws.

Fit anti-down draught cowl.

Do not secure the cowl as it must be removed for cleaning.

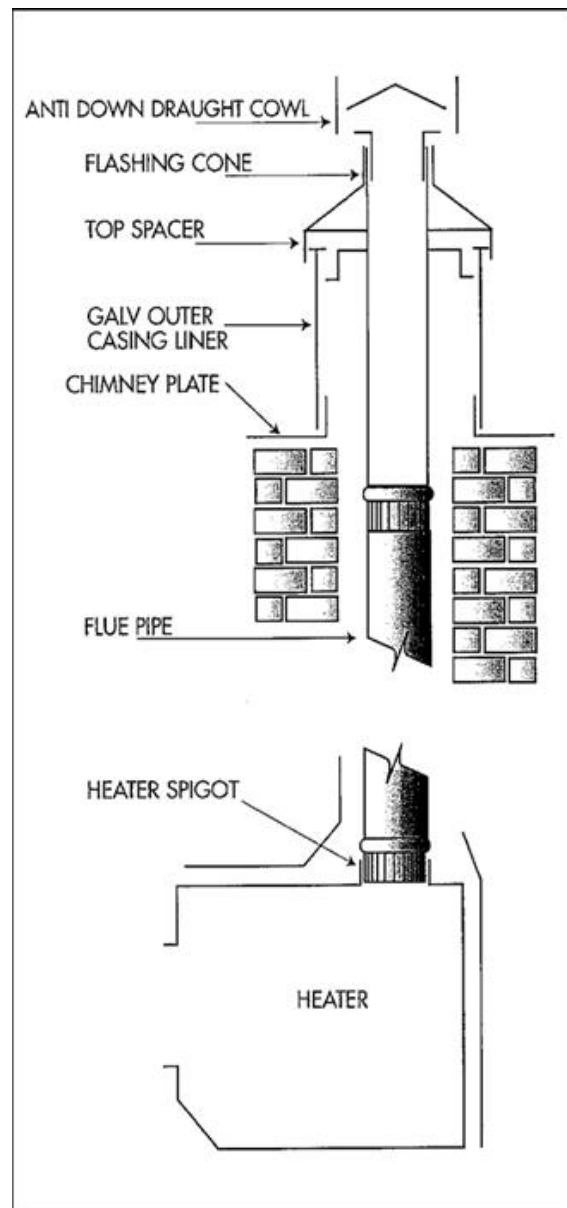

## 6C. Insulation Requirements for Masonry Install

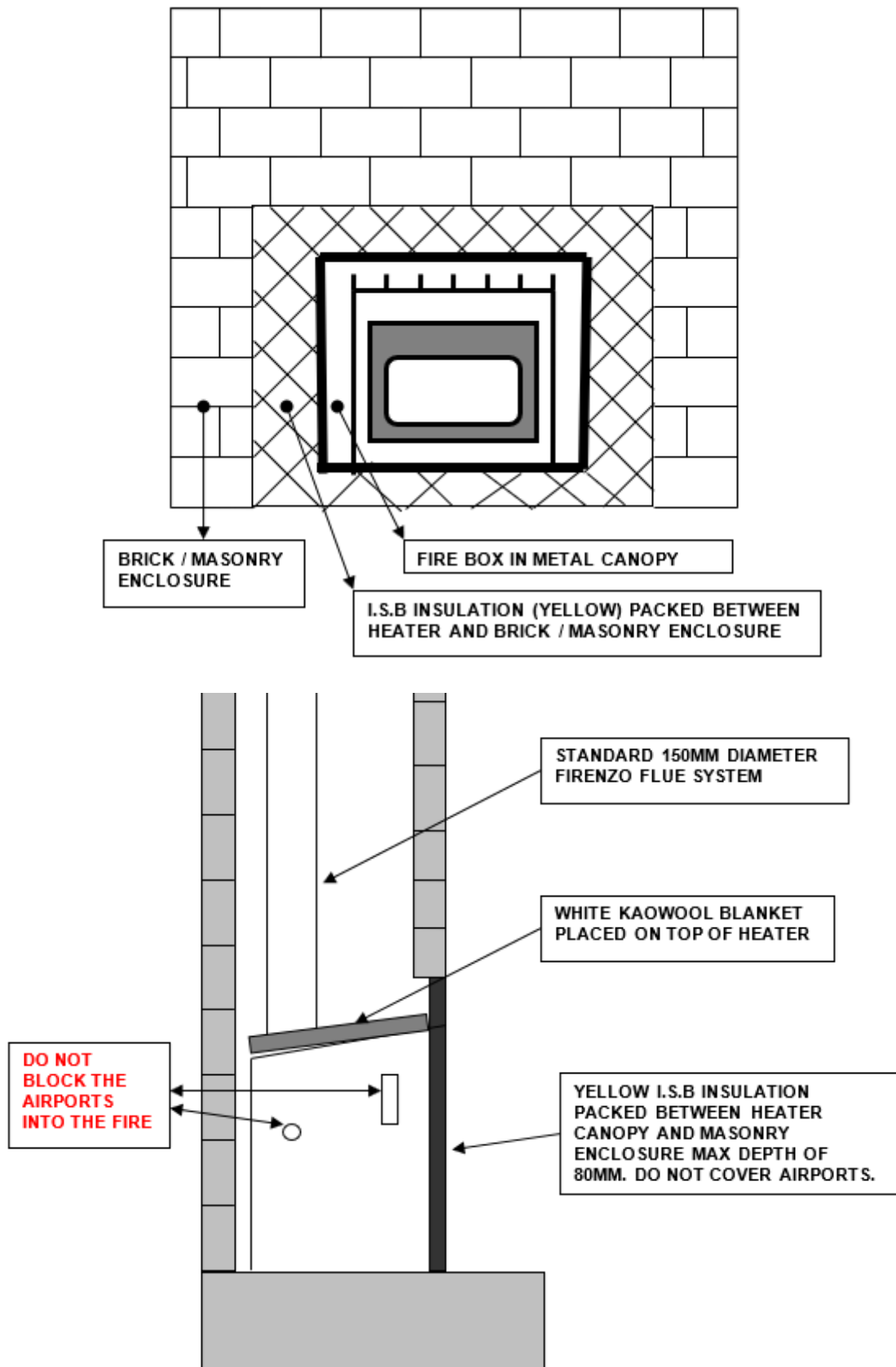

## 6D. General Assembly of Topaz Fire in Masonry

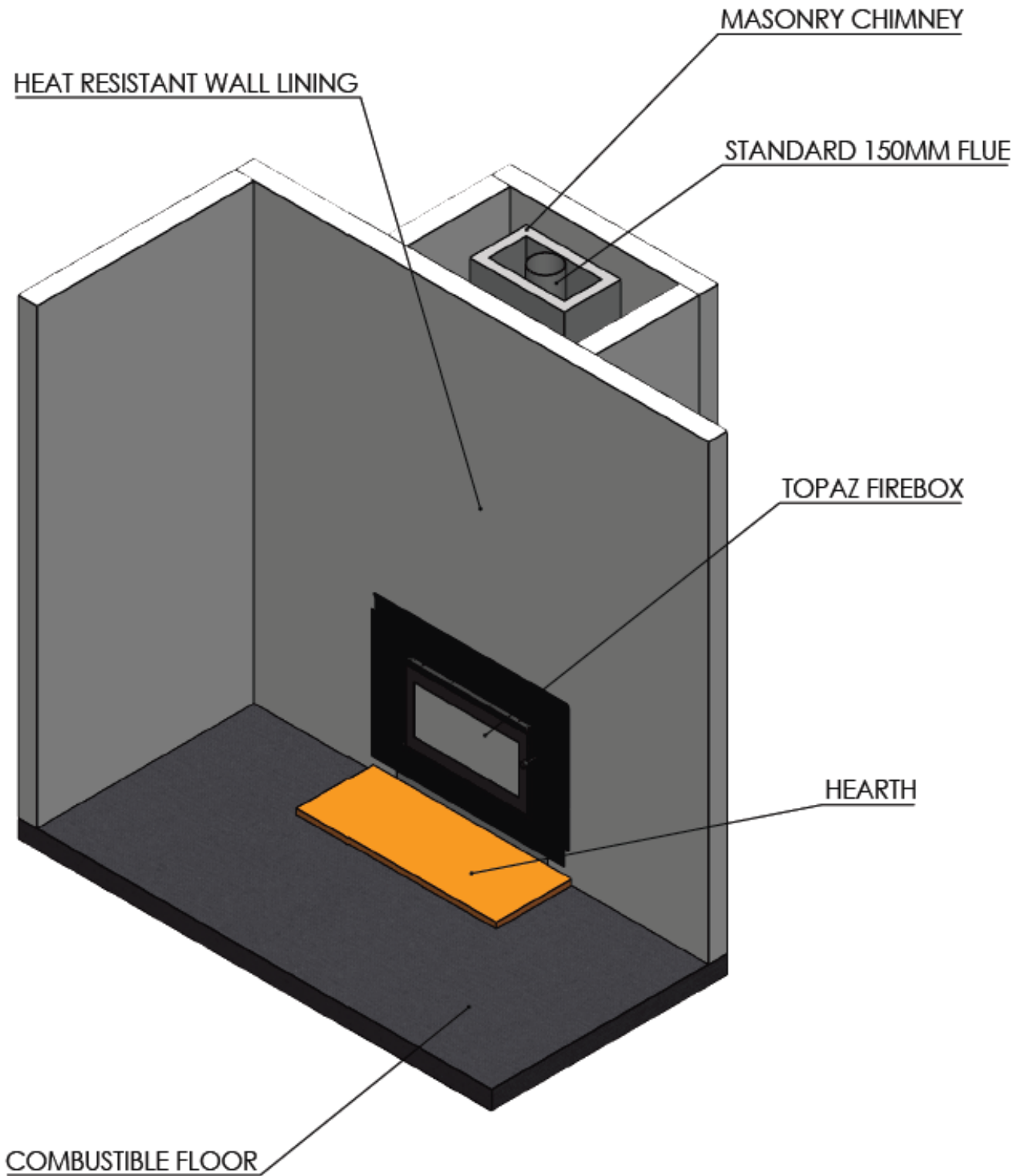

## 6E. Firebox Canopy Clearance in Masonry Installation

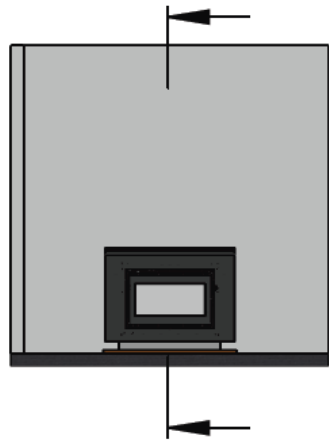

THE MINIMUM CLEARANCE BETWEEN THE STEEL CANOPY AND MASONRY CHIMNEY IS 50MM

THE FIREBOX MUST BE INSTALLED A MINIMUM OF 120MM ABOVE THE HEARTH

THE FIREBOX MUST BE INSTALLED ON A NON-COMBUSTIBLE BASE

THE EXTERNAL AIRVENT IN THE MASONRY CHIMNEY BREAST MUST BE A MINIMUM SIZE OF 100MMX100MM OR EQUIVALENT AREA

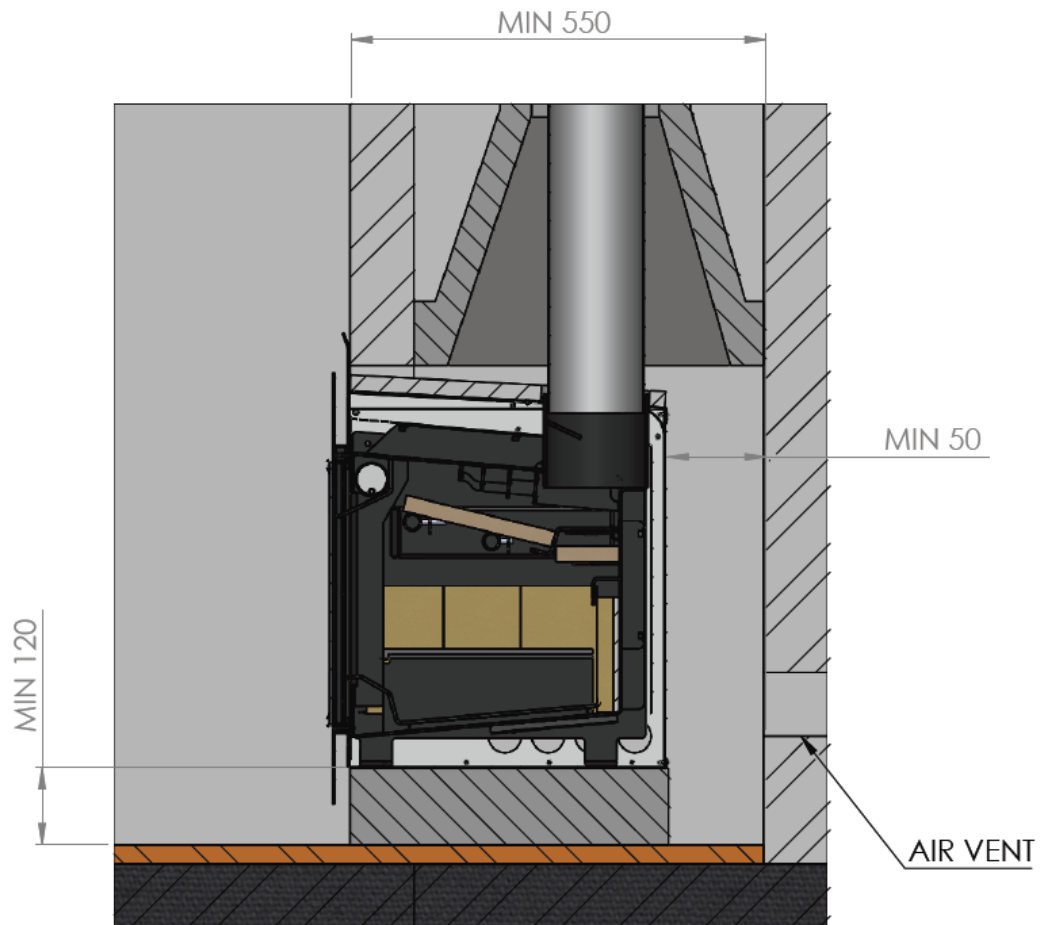

SECTION VIEW

ALL DIMENSIONS IN MM UNLESS OTHERWISE STATED



# 6F. Insulation Requirements for Masonry Installation

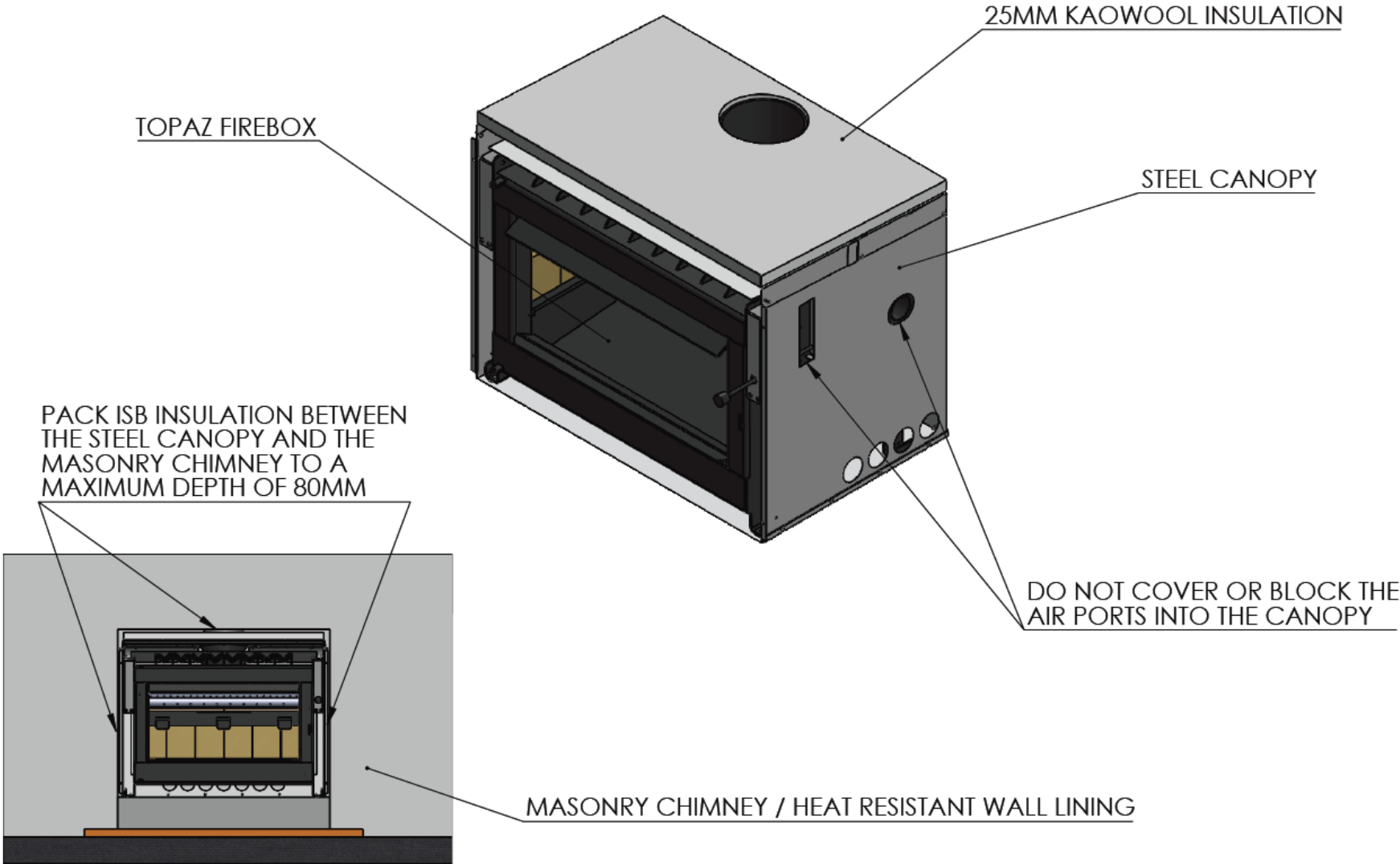

## 6G. Topaz Steel Canopy Dimensions

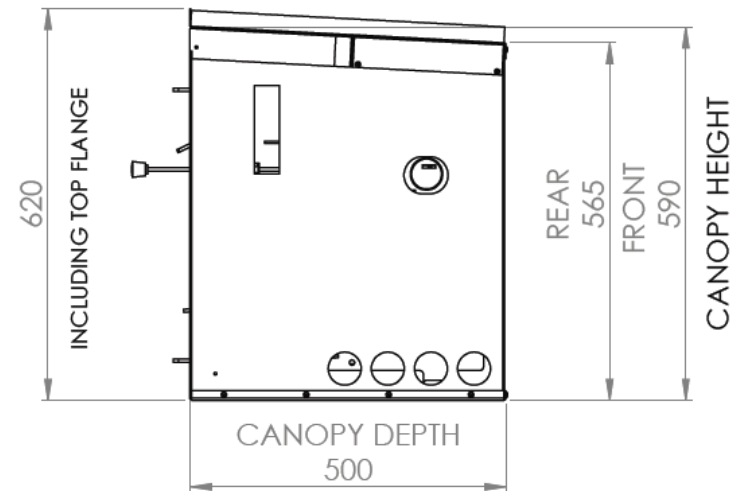
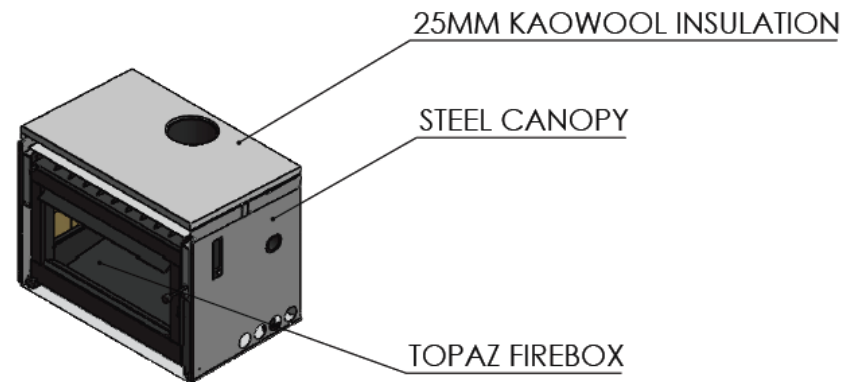
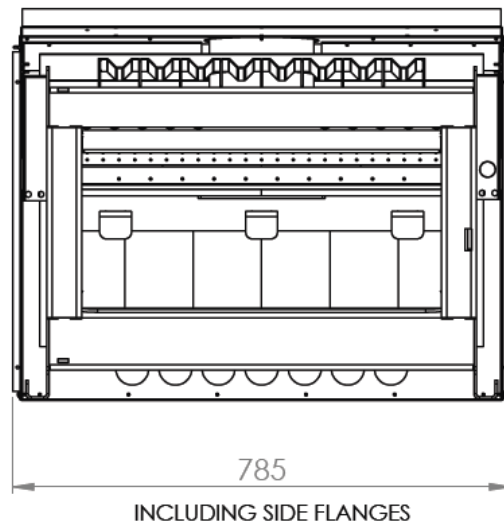
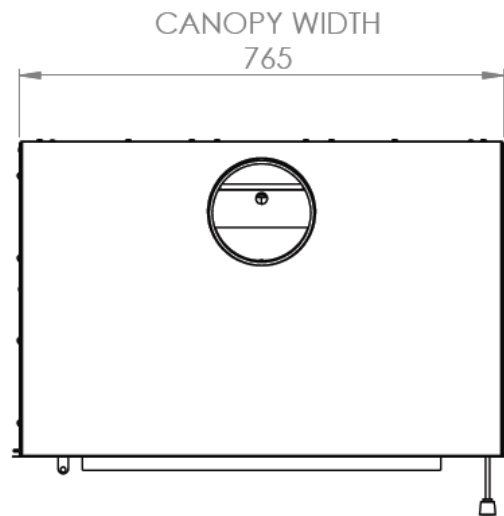

TOLERANCE  $\pm 3$ MM ON STEEL CANOPY DIMENSIONS  
ALL DIMENSIONS IN MM UNLESS OTHERWISE STATED

## 7. Zero Clearance Installation (Built-In Fire Canopy)

**A Zero-Clearance Box (Built-In Fire Canopy) is required if the Fire is not being installed in a masonry fireplace.**

**The following pages outline the installation of the Topaz Fire in a Built-In Fire Canopy.**

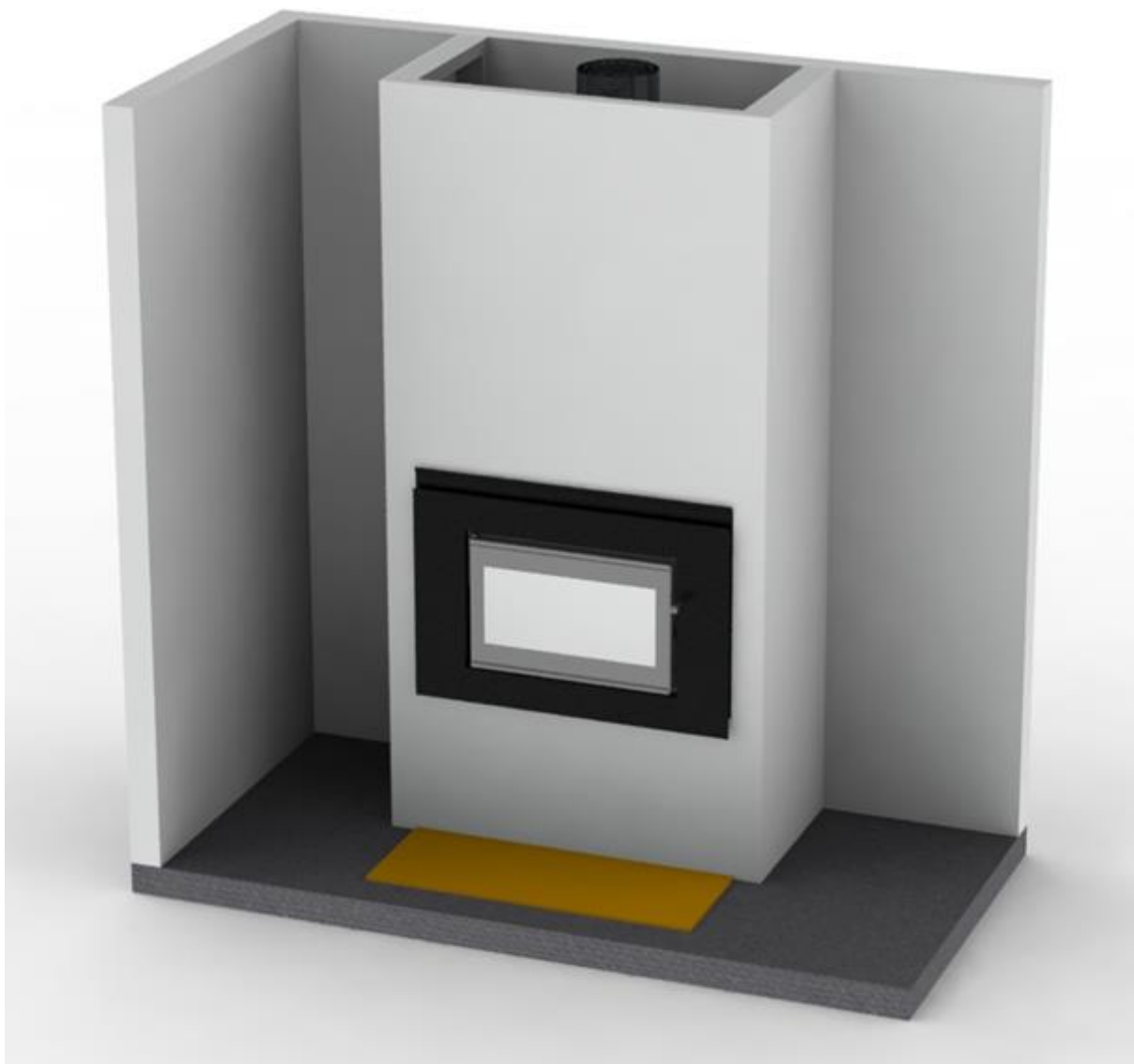

## 7A. Opening Dimensions for Built-In Fire Canopy Installation

The Built-In Fire Canopy should be installed in the timber chimney chase prior to fitting the heat resistant wall lining. The opening cut in the wall lining should only be large enough to accept the firebox in its steel housing. The wall lining is intended to cover the front edges of the Built-In Fire Canopy and the insulated base.

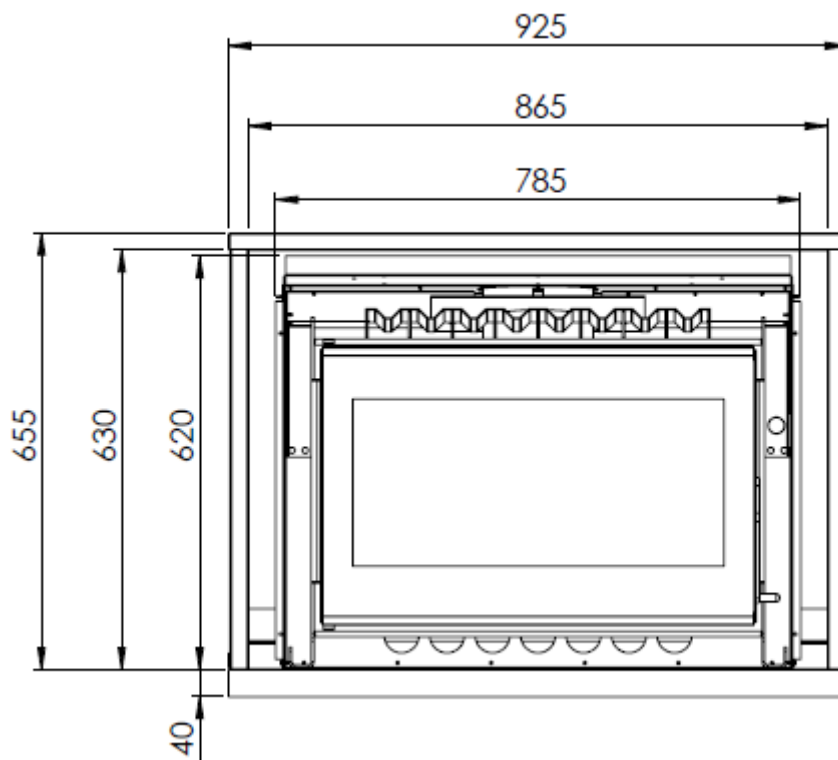

The hole cut in the wall lining of the chimney chase should meet the following dimensions

**Minimum Width = 785mm**      **Maximum Width = 865mm**

**Minimum Height = 620mm**      **Maximum Height = 630mm**

The height is measured from the base of the steel canopy.

### Note

The bottom edge of the hole should be cut in line with the steel base of the Built-In Fire Canopy so that the Firebox can be slid into position. The 40mm insulated base should be completely below this cut line.

## 7B. Assembly Instructions

- 1) Carefully remove all packaging.
- 2) Construct the Built-In Fire Canopy and install into framework following the guidelines in Sections 7C – 7I.
- 3) Before inserting the Fire into the Built-In Fire Canopy, place the 25mm white Kaowool blanket on top of the steel canopy.
- 4) Slide the firebox into the opening so that the outer casing return folds are flush with the face of the Built-In Fire Canopy.
- 5) Bolt the Fire through the Built-In Canopy to the supporting structure below using the restraint points at the two front legs of the Fire.
- 6) Install Flue System as per instructions in Section 7C.
- 7) Fill any gaps between the steel canopy and the Built-In Fire Canopy with the yellow ISB insulation provided. See note below.
- 8) Assemble and fit the fascia.

### **NOTES**

**Due to New Zealand being an earthquake-prone country it is important to anchor the fire down in case of movement.**

**In the case of installing this Fire in a built-in-fire canopy, it is necessary to install additional ventilation into the chimney cavity as per AS/NZ 2918 3.4.1.2 to assist air flow into the fire. This ventilation should not be taken/drawn from the room that the fire is installed in. This air vent should measure 100mmx100mm or equivalent area.**

**Under no circumstances should the airports on the side of the Fire be restricted or blocked.**

## 7C. Insert Flue System for a Built-In Fire Canopy Installation

DIMENSIONS IN MILLIMETERS  
UNLESS OTHERWISE STATED

### FASCADE / CHASE TERMINATION

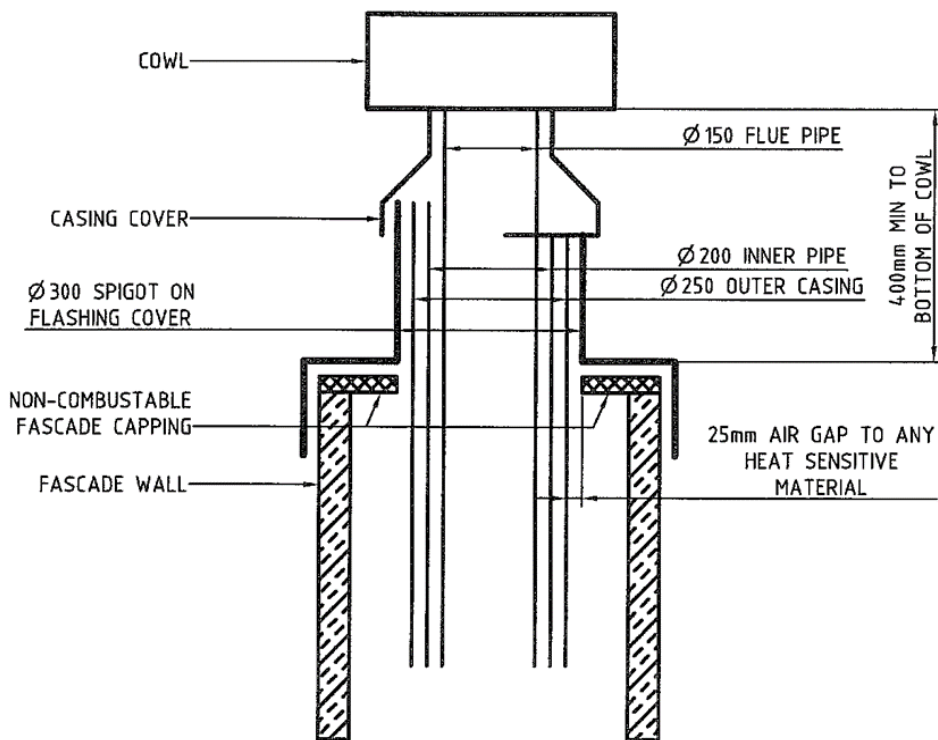

Please Note:

Flue system must comply to AS/NZS2918:2001 Section 4

1. The fascade capping must be made from a non-heat sensitive material i.e. 9.5mm Supalux or Hebel stone. Must be placed across the top of any wood framing.
2. The chimney flashing must have a 25mm free air clearance to the Ø250 outer casing, with a suitable oversize casing cover and a 250mm to 300mm spacer preventing the air gap from being closed. This permits air to freely flow from the fascade / chase cavity to atmosphere preventing any temperature rise within the cavity.
3. Fascade canopy must comply to all building regulations and section E2 of the building code.

## 7D. Insulation Requirements For A Built-In Canopy Installation (Zero Clearance Box)

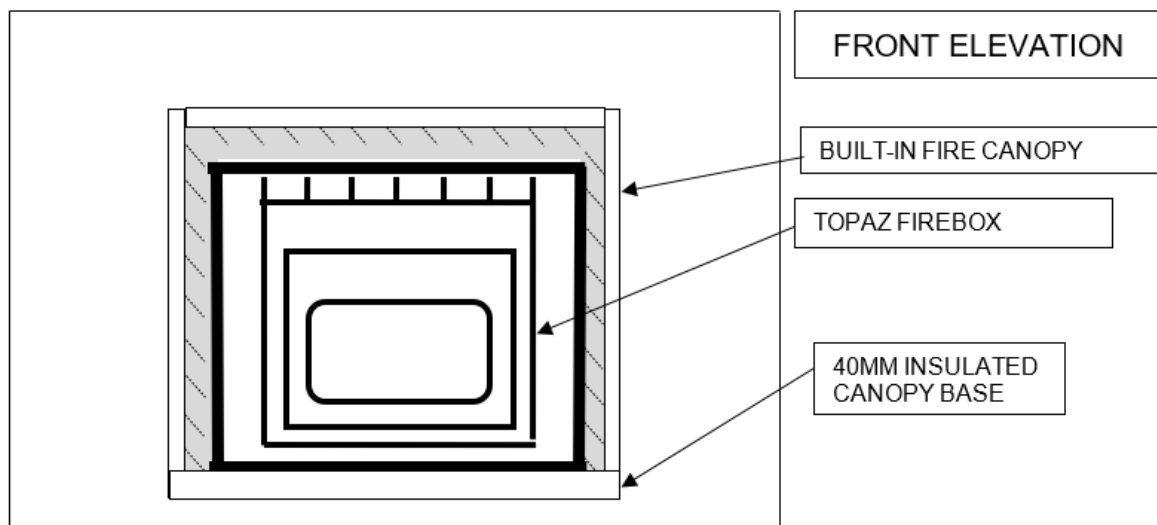
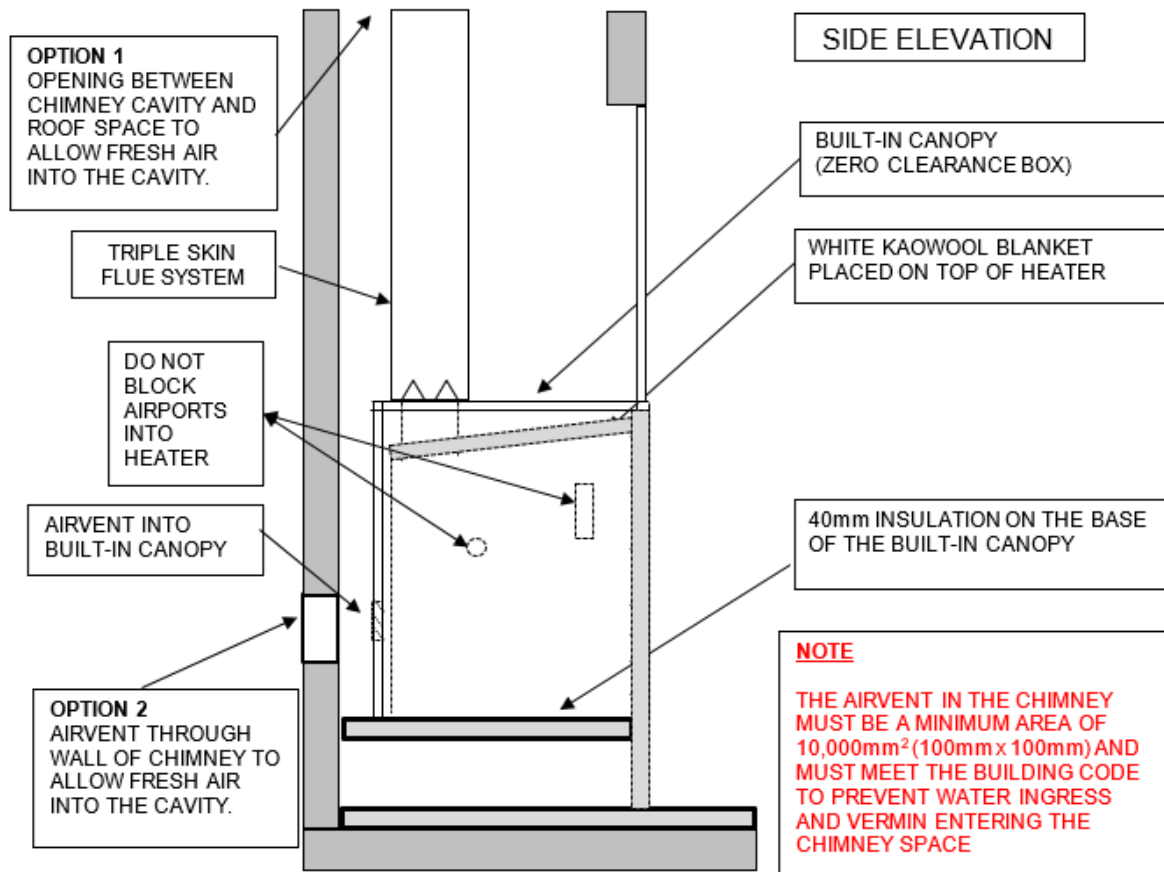

## 7E. General Assembly of Topaz Fire in a Non-Masonry Installation

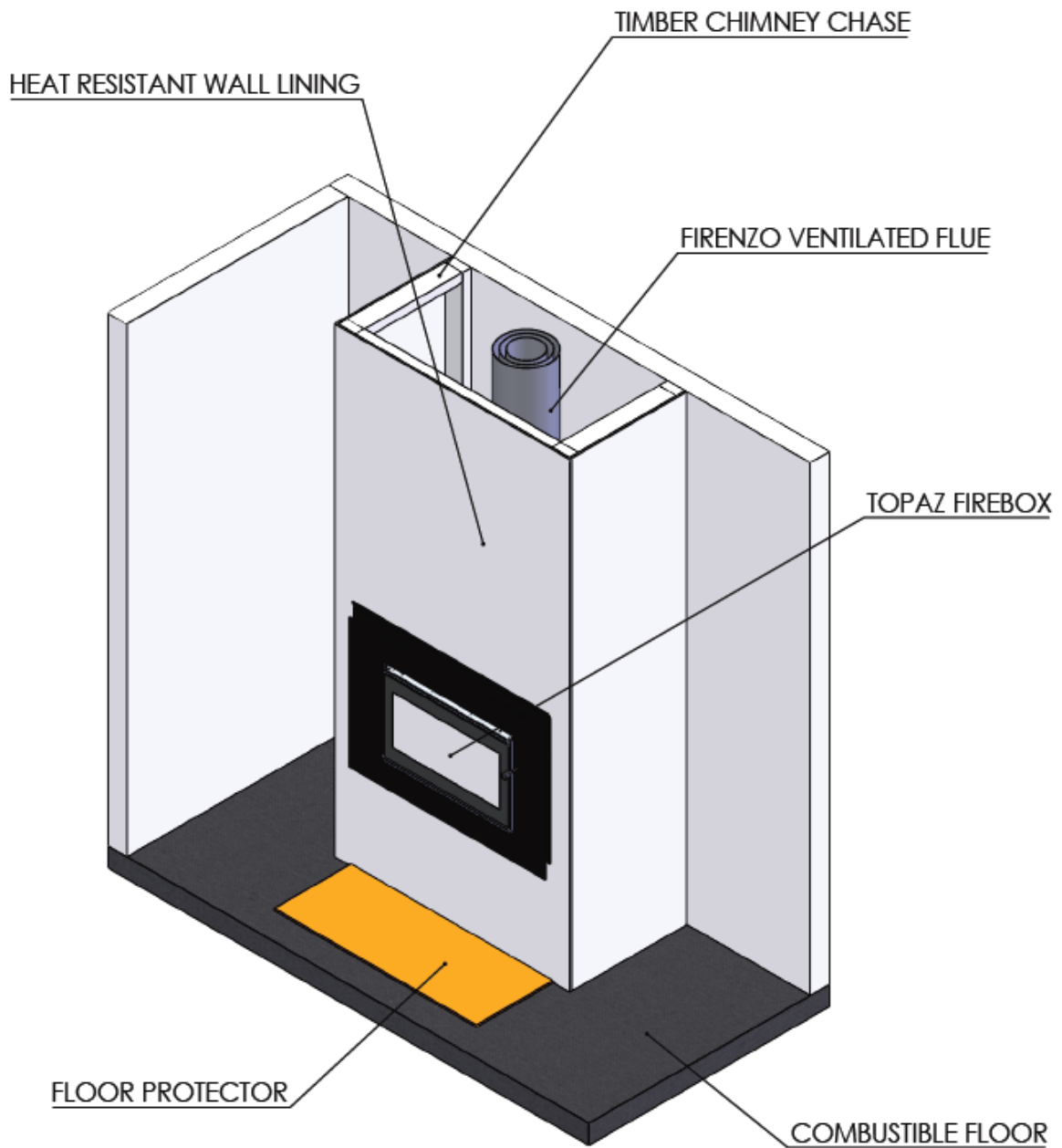

**Note** A heat resistant wall lining must be used on the front face of the timber chimney chase, such as Promatech H, Eterpan LD or Pacblid Pro, and should extend to the ceiling (nominally 2.4m). It is recommended to use a full 1200 x 2400mm sheet of heat-resistant board.



## 7F. Minimum Distances for Built-In Fire Canopy

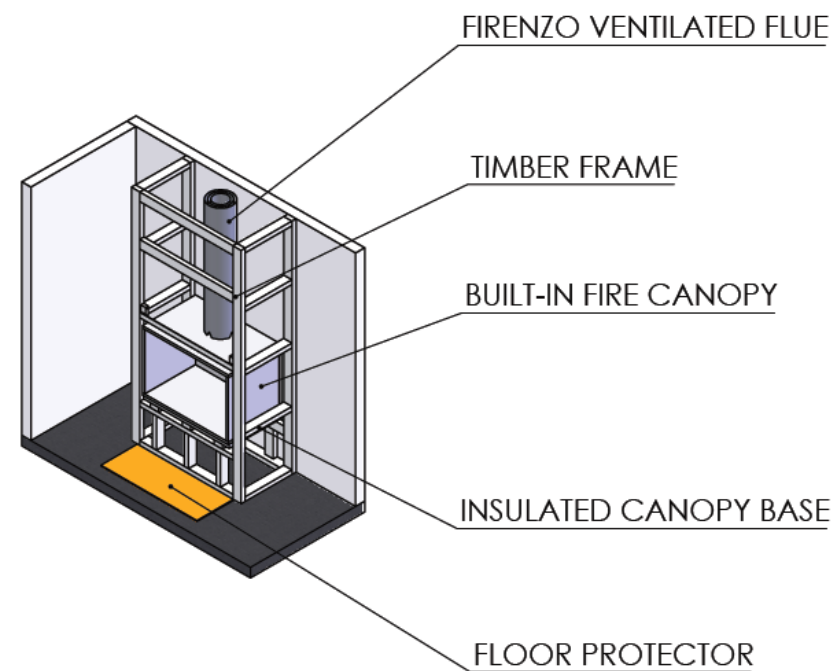
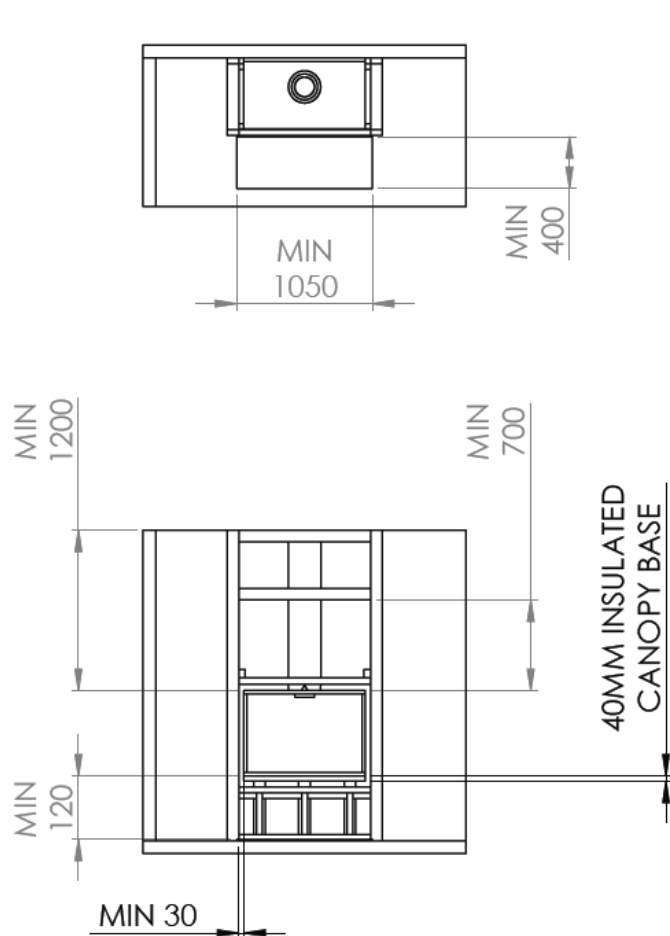

40MM INSULATED BASE BETWEEN BUILT-IN FIRE CANOPY AND SUPPORTING TIMBER STRUCTURE

MINIMUM 30MM GAP BETWEEN THE SIDES OF THE BUILT-IN FIRE CANOPY TO THE TIMBER FRAMING

MINIMUM DISTANCE FROM THE STEEL BASE OF THE BUILT-IN FIRE CANOPY TO THE FLOOR PROTECTOR IS 120MM

MINIMUM DISTANCE FROM THE TOP OF THE BUILT-IN FIRE CANOPY TO THE FIRST HORIZONTAL TIMBER IS 700MM

MINIMUM DISTANCE FROM THE TOP OF THE BUILT-IN FIRE CANOPY TO THE CEILING IS 1200MM

## 7G. Firenzo Ventilated Flue and Steel Brace Detail

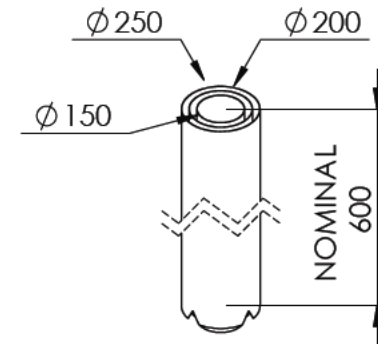
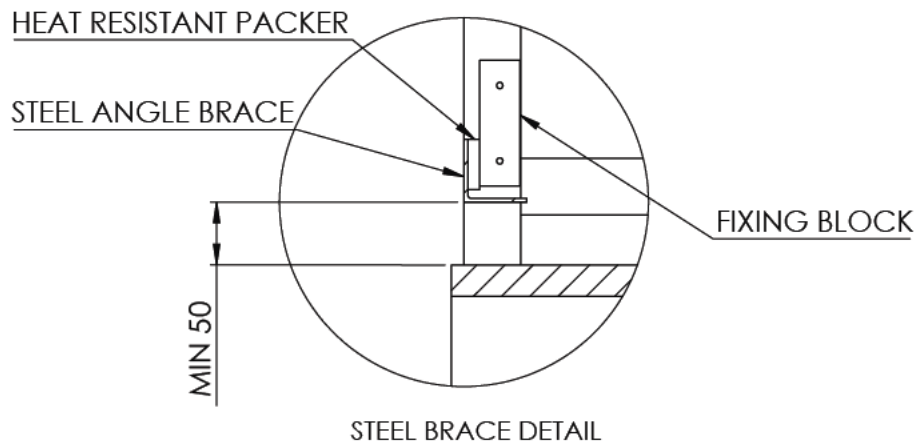
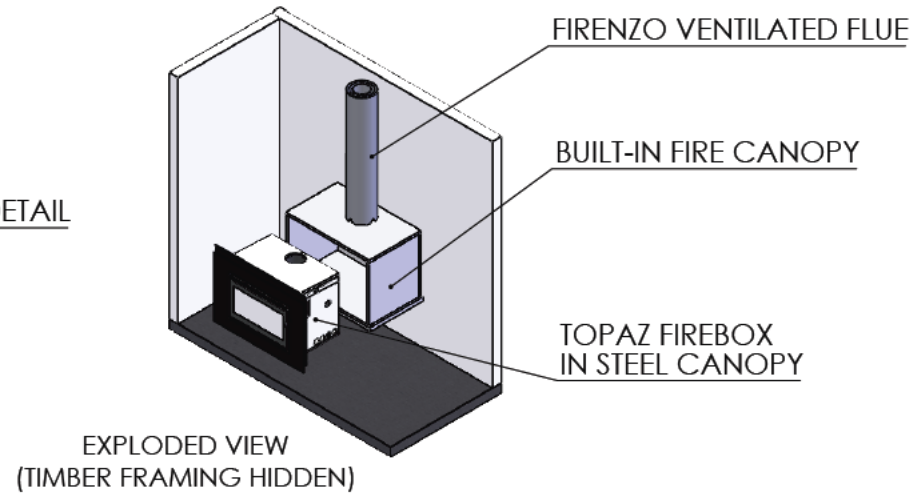
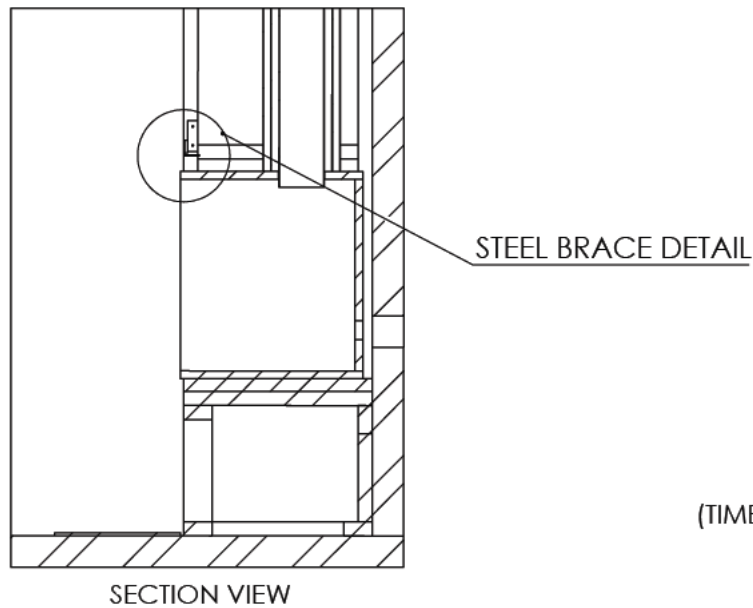

**NOTE:**  
MINIMUM TOTAL FLUE LENGTH IS 4200 MM

ALL DIMENSIONS IN MM UNLESS OTHERWISE STATED

# 7H. Topaz Built-In Fire Canopy

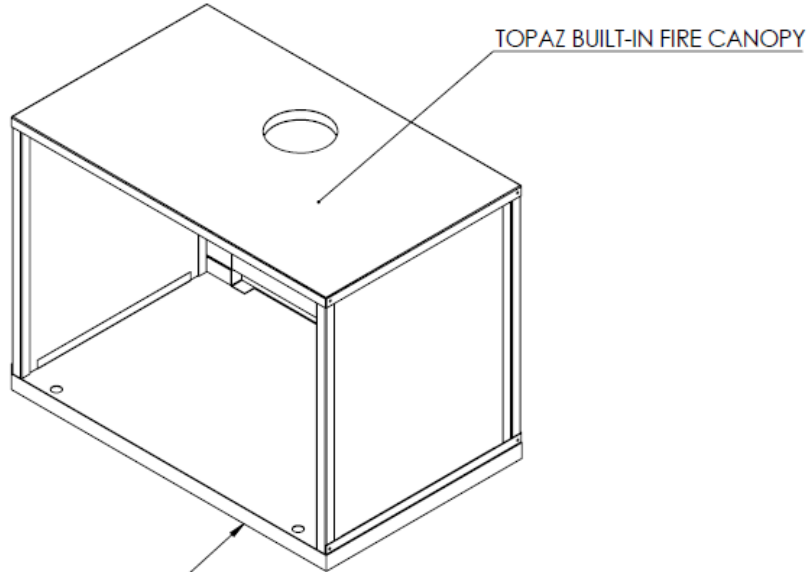
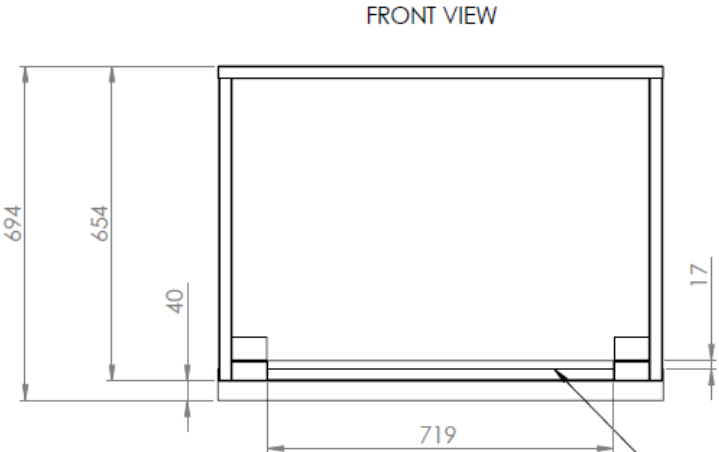
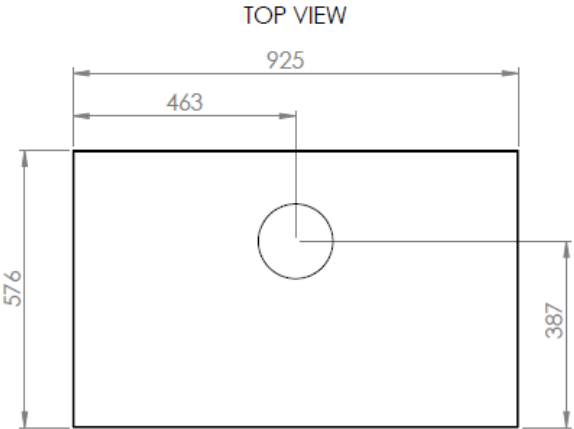

VENTILATION SLOT IN THE BACK OF THE BUILT-IN FIRE CANOPY  
TOTAL AREA >12000 MM2

ALL DIMENSIONS IN MM UNLESS OTHERWISE STATED

# 7I. Assembly of Built-In Fire Canopy

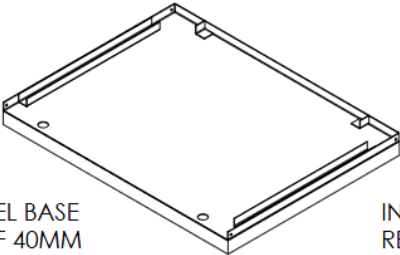

PLACE STEEL BASE ON TOP OF 40MM INSULATED BASE

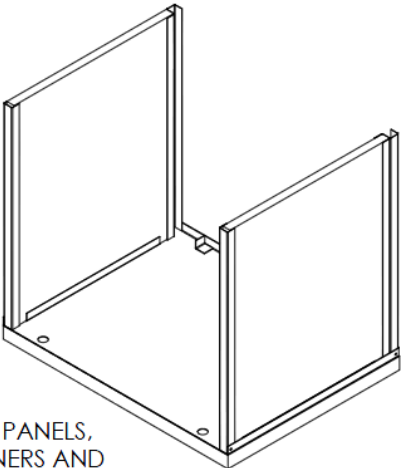

INSERT SIDE PANELS, REAR CORNERS AND FRONT CAPPING

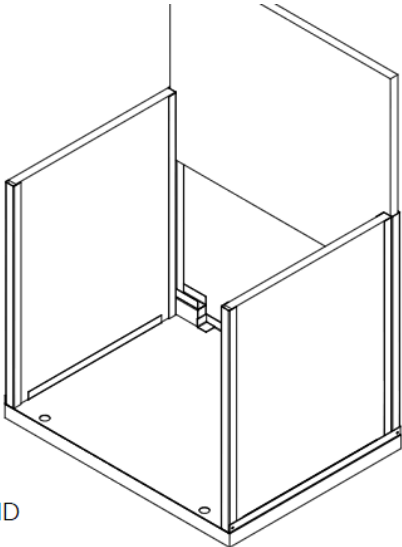

INSTALL REAR UPSTANDS AND BACK PANEL

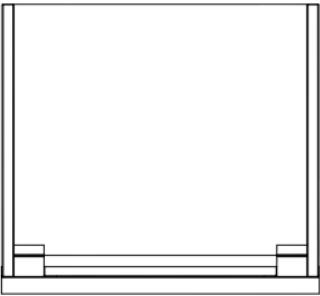

ENSURE THERE IS A GAP BELOW THE BACK PANEL TO ALLOW AIR FLOW

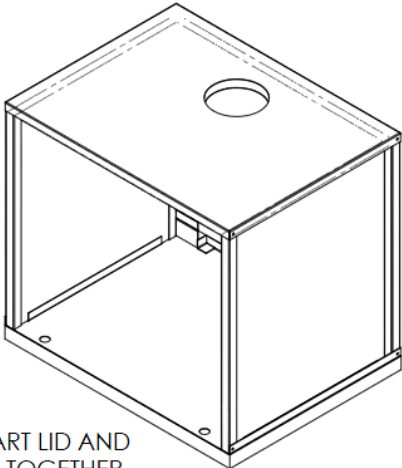
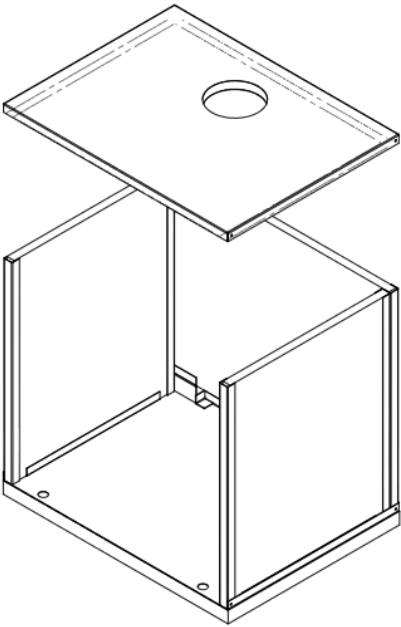

INSTALL 2-PART LID AND FASTEN BOX TOGETHER WITH SCREWS PROVIDED

## 8. Topaz Lowline

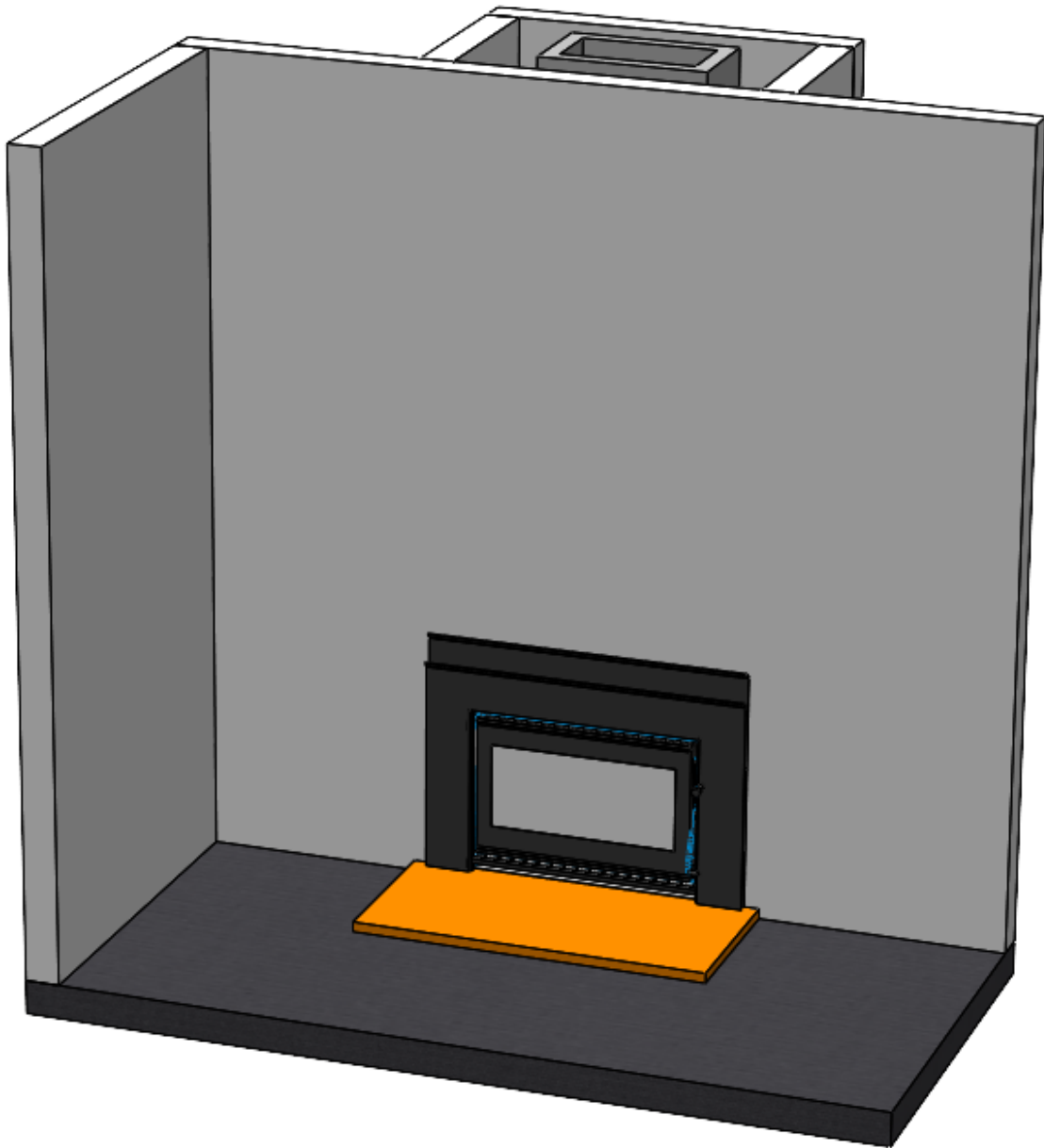

The Topaz Lowline is designed for installation in existing masonry fireplaces as it allows for the bottom edge of the fascia to sit flush with the hearth.

The Topaz Lowline must be installed on a non-combustible hearth which extends **a minimum of 500mm** forward from the chimney breast.

## 9. Warranty

### Terms applicable to Firenzo Woodfires Warranties (current as at 29th May 2015)

- 1) Hewitsons Limited (company number 569753) with a specified address of 98 Niven Street, Onekawa, Napier and trading as Firenzo Woodfires gives:
  - a ten (10) year warranty but ONLY for the steel firebox, fascias and cast-iron components of all Firenzo wood fires.
  - a one (1) year warranty for all other parts and finishes of a Firenzo wood fire including its refractory linings, glass, air supply components, wetback, seals, tapes, extrusions.
- 2) The warranty periods commence on the original date of sale of the relevant Firenzo wood fire to a consumer. Please see paragraphs 5 and 8.
- 3) The warranties are given in respect of any defects in the specified Firenzo component parts and materials and Firenzo workmanship that render the component parts and materials unfit for normal domestic use.
- 4) The warranties have qualifying limitations, restrictions and conditions attached to them. Please see paragraphs 5, 6, 7, 8, 10 and 14.
- 5) Firenzo gives the warranties only to New Zealand consumers as defined in the Consumer Guarantees Act 1993. Please also see paragraph 17. The warranties are additional to the rights available to consumers against the manufacturer under the Consumer Guarantees Act 1993. To the fullest extent permitted at law, no other warranties or guarantees, express or implied, are assumed or given by Firenzo to any person with respect to the quality, merchantability, description or fitness for purpose or use of Firenzo wood fires or their component parts and materials.
- 6) Firenzo is not liable for, and to the maximum extent permitted by law excludes any liability for, any consequential loss or damage arising out of the installation, ownership or use of a Firenzo wood fire. To the extent such liability cannot lawfully be excluded, Firenzo's liability is limited to the purchase price paid for the Firenzo wood fire.
- 7) The warranties do not apply to:
  - normal wear and tear.
  - performance issues or limitations affecting a Firenzo wood fire arising out of:
    - prevailing site conditions such as downdraughts or insufficient draw.
    - or from, incorrect servicing adjustments or incorrect flue.
- 8) The warranties are valid only if the original purchasing consumer completes and returns a copy of the prescribed Warranty Registration Card to Firenzo at the specified address, dated the sale date, and specifying the residential address where the Firenzo wood fire is installed. The original purchasing consumer should keep their part of the Warranty Registration Card for validating warranty claims.
- 9) The warranties may be assigned to other consumers (as defined in the Consumer Guarantees Act 1993) on any sale of the residential property where a Firenzo wood fire has been installed.
- 10) For information (including claim procedures) concerning potential claims, potential warranty claimants should contact:
  - in the first instance, the retailer/dealer from whom the Firenzo wood fire was originally purchased or
  - (if the retailer/dealer is not contactable or does not address the claim to the claimant's satisfaction) Firenzo at the specified address, including as appropriate to arrange an inspection of the Firenzo wood fire.

- 11) After complying with paragraph 10, for valid claims, a warranty claimant must submit a completed warranty claim form (please see Firenzo's website, or contact Firenzo, for this form) or other form acceptable to Firenzo providing details of the consumer's warranty from the Warranty Registration Card (including its date of issue) and specifying the defect:
- to the retailer/dealer from whom the Firenzo wood fire was originally purchased; or
  - to Firenzo at the specified address.
- 12) The warranty claimant is responsible for paying any service call fees, transport charges and for any damages and loss incurred in transit to the Firenzo wood fire or its component parts and materials, to and from Firenzo or its designated accredited agent. Where Firenzo honours a warranty, as described in paragraph 13, it will reimburse the warranty claimant any transportation costs they have incurred.
- 13) Firenzo or its designated accredited agent (please see paragraph 16) will replace any component parts and materials covered by the warranties or the entire Firenzo wood fire, at its discretion, where Firenzo is reasonably satisfied a defect is solely due to faulty Firenzo workmanship or materials.
- 14) Firenzo may decline (in whole or part) to honour a warranty claim:
- Until any amounts due but unpaid by a consumer in respect of the Firenzo wood fire or its servicing are paid.
  - Until Firenzo is provided with the applicable compliance and installation permits (please see below);
  - If it appears to Firenzo that the Firenzo wood fire has:
    - not been installed correctly at the specified residential address, or
    - not been operated and maintained strictly in accordance with the manufacturer instructions, AS/NZS 2918:2001 and any relevant building code or consent or these warranty terms.
    - not been inspected and confirmed after installation as a compliant installation (with the requisite specifications and permits)
    - not been regularly maintained and at least annually serviced
    - been subject to misuse, neglect, or accident in transit, storage, or use
    - been damaged by water ingress in any way, including any surface rust which has occurred in transit or storage. However, this exclusion will not apply to any damage to the Firenzo wood fire which is determined to have been caused by wetback leakage attributable to faulty Firenzo component parts or materials or workmanship
    - been over fired or has used any fuel other than clean dry firewood (having 25% or less moisture content), including any chemically treated timbers or driftwood
  - if it appears to Firenzo that the defect is attributable to a failure to replace consumable parts or components or materials within a timely manner to maintain their durability.
- 15) Firenzo reserves the rights to alter or supplement the warranties, but no alteration will reduce a consumer's rights under the warranties that applied at the date of original acquisition of the applicable Firenzo wood fire. In the event of any inconsistency between the warranties and any other written Firenzo material, including a manual, the warranties shall prevail to the extent of the inconsistency.
- 16) No person other than a designated accredited agent can bind Firenzo with respect to Firenzo's obligations under the warranties, and then only in accordance with the agent's actual authorities. A person is a designated accredited agent where they are identified and certified in writing by Firenzo to be such with their authorities specified in the certificate. Consumers must take reasonable steps to satisfy themselves that they are dealing with designated accredited agents.
- 17) The warranties do not apply to export sales of Firenzo wood fires. Separate terms apply to those sales. For any questions about the warranties or this document please contact Firenzo at its specified address, on telephone 06 8438260, by email at [firenzo@firenzo.co.nz](mailto:firenzo@firenzo.co.nz) or via the Firenzo website [www.firenzo.co.nz](http://www.firenzo.co.nz).

- 18) This document is intended to form part of (and may be expressly referenced in) the terms of sale and purchase by every original New Zealand consumer of a Firenzo wood fire. Without limiting that intent:
- by the act of completing and returning a copy of the prescribed Warranty Registration Card to Firenzo at the specified address (or other address for the time being), a consumer is also deemed to acknowledge that he or she is bound by the warranty terms;
  - a copy of this document is to be executed by Firenzo as a deed poll in favour and for the benefit of the New Zealand consumers described in it and to be kept for inspection purposes with Firenzo’s corporate records at its specified address.

Model: **TOPAZ LEB / RU**

Serial No: \_\_\_\_\_

Date of Purchase: \_\_\_\_\_

Purchased from: \_\_\_\_\_

**Please complete for your reference.**

**Note**

The Warranties Registration Card is located in the information pack that accompanied your new wood fire. It **MUST** be filled out and returned to Firenzo.





# Firenze Woodfires

*Manufacturers of*

## Free-Standing Woodfires

**Bronte**

**Contessa**

**Encore**

**Lady Kitchener**

**Napier**

**Viking**

**Vision**

## Insert Woodfires

**Aqualux**

**Athena Bay & Flush**

**Forte Bay & Flush**

**Kompact Athena**

**Kompact Deco**

**Kompact Diva**

**Kompact Forte**

**Kompact Plaza**

**Kompact Serenity**

**Topaz**

98 Niven Street

PO Box 3231

HB Mail Centre

Napier 4142

**Phone: 06 8438260**

**Website: [www.firenze.co.nz](http://www.firenze.co.nz)**

**Email: [firenze@firenze.co.nz](mailto:firenze@firenze.co.nz)**