

Cru.

Cr30

Wood Fired Oven User's Manual
- Designed and Manufactured in Portugal -

www.cruovens.com



Cr30 Wood Fired Oven User's Manual | www.cruovens.com

Components & Assembly

Dimensions: L415mm; W495mm; H705mm - Weight: 15 Kg



Embers rake



Pizza peel

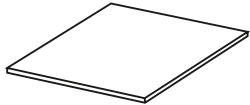

Refractory brick

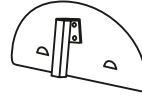

Door



Chimney

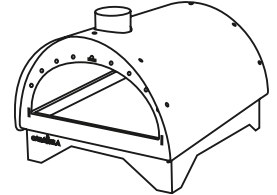

Oven

In order to have your Cr30 oven ready for cooking, you just need to get the components together and **REMOVE PROTECTIVE FILM COVERING OVEN AND COMPONENTS**

1

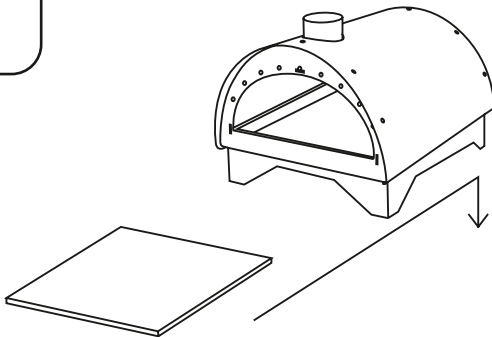

Insert refractory brick into the oven

2

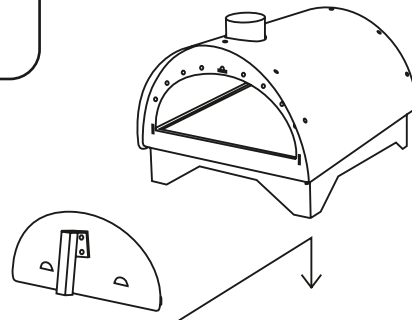

Place door in oven's front

3

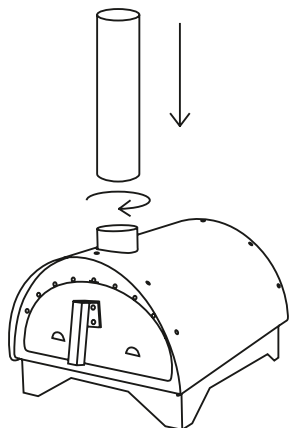

Fit chimney in top and rotate 90°

4

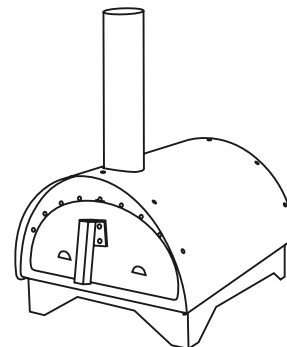

Your oven is ready!

Safety guidelines

1. Please keep children and pets at a safe distance at all times.
2. While operating, your Cr30 oven will reach very high temperatures. **Always use protective heat resistant gloves to handle tools and pots.**
3. Beware of flying sparks from the mouth of the oven.
4. Ensure that no combustible materials are within range of your oven at any time.
5. Do not shut the oven's doors while there is fire with flames inside the oven. Closing the door will cut off oxygen to the fire, eventually weakening the flames or causing a sudden fire eruption when the door is removed and oxygen flows into the oven again.
6. Do not alter the oven in any way, it has been designed in order to optimize its safety and functionality.
7. Do not burn contaminated wood (with chemicals), rubbish, or flammable fluids in your oven.
8. **DO NOT CARRY OVEN WHEN HOT OR WARM.**



NEVER PUT YOUR HANDS OR ARMS INSIDE OR OUTSIDE THE OVEN WHEN HOT, UNLESS YOU ARE WEARING ADEQUATE HEAT RESISTANT GLOVES.

CAUTION: TEMPERATURES OVER 450°C / 850°F MAY CAUSE THE DETERIORATION OF THE OVEN AND ITS COMPONENTS.

Fire Ignition Guidelines

1. Always use natural untreated firewood, never pressure treated or painted wood such as old fence posts. We advise that you try to use silver birch.
2. Do not use pellets, chipped wood products, or sappy wood within your oven.
3. **NEVER USE ANY TYPE OF ACCELERANT, SUCH AS PETROL, PARAFFIN OR SIMILAR PRODUCTS. THESE ARE EXTREMELY DANGEROUS AND CAN LEAD TO EXPLOSIONS WITHIN YOUR OVEN.**

Fire ignition instructions

DO NOT CLOSE THE OVEN DOOR WHILE THERE IS FIRE WITH FLAMES INSIDE THE OVEN

- 1 - Build a tower of kindling over a natural firelighter in the middle of the refractory brick floor, towards the front of the oven.
- 2 - Keep adding kindling pieces to the fire (please respect safety guidelines) every couple of minutes to help the fire gain size and heat; after a few minutes the fire should have built to a reasonable size and the heat should now be quite intense (when you are unable to hold your hand any closer than about 9" / 23cm from the mouth of the oven).

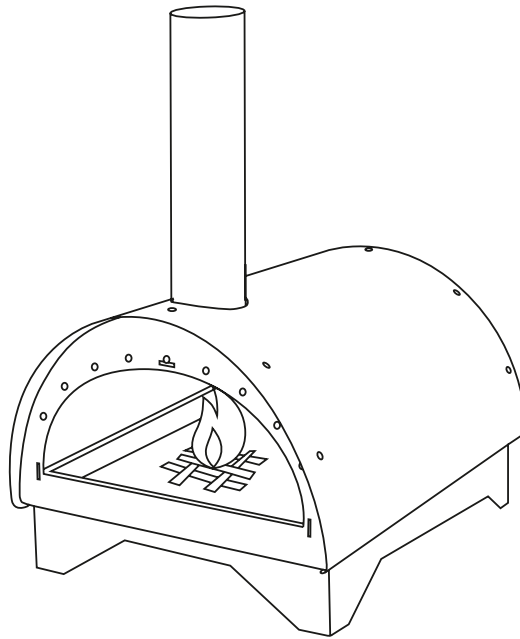

- 3 - Allow the fire to keep building for a further 5 minutes (keep feeding it) and the fire should then be ready to push to the back of the oven using the embers rake.
- 4 - Once the fire has been pushed back, add around 3 or 4 pieces of quality wood (please respect the combustibile guidelines), we recommend pieces of around 8-10" x 2" / 20 x 5cm.
- 5 - You should now have a good bed of red embers along with a healthy flame and are now ready to start cooking.
- 6 - Every 15 minutes or so, you will see the flames are start to dissipate. If you wish to keep cooking, simply add 3-4 more 6" / 15cm logs accordingly in order to maintain a healthy fire and heat. Keep in mind that closing the oven's door will cut off oxygen to the fire.



FIRE IGNITION INSTRUCTIONS LINK: www.vimeo.com/543353814

*Please see line 5 of safety guidelines

Maintenance

1. Over time, the top of the opening and the door on your oven can become black, as the soot from the fire builds up. To minimize, simply clean the oven opening using a soft sponge with soap and water.
2. The floor of the oven should be cleared of ashes and embers when fully cold. Once you have removed the embers, please clean the refractory brick by using a brush to dust it down and remove any embers residue.



NEVER PUT YOUR HANDS OR ARMS INSIDE OR OUTSIDE THE OVEN WHEN HOT, UNLESS YOU ARE WEARING ADEQUATE HEAT RESISTANT GLOVES.

1. Please ensure that the ashes have fully cooled down before disposal (natural cooling can take several hours).
2. It is perfectly acceptable to turn the refractory brick over between uses.
3. **DO NOT USE THE REFRACTORY BRICK WHEN WET AS IT ABSORBS MOISTURE, CAUSING IT TO CRACK (WHICH DOES NOT DIMINISH BRICK'S ABILITY TO COOK).**
4. Before storing the oven for a long period apply WD-40 or paraffin wax, using a cloth or cotton buds, to the exterior metal surfaces of the oven to protect against corrosion.
5. When not in use, the oven should be covered or shielded from the elements.

Benefits of cooking with fire

When cooking with fire, it is essential to start by making a high fire, allowing the oven to reach a high temperature. Once the oven is heated, the refractory brick floor becomes a radiator, enabling food to cook from underneath as well as from above. In your Cru Oven, the fire and smoke are drawn through the oven and across the food as it cooks, adding an incredible flavor to your cooking.

This is something impossible to achieve when cooking by other means (or methods). Heat will allow food to cook, while flames will roast. The balance between the heat within the oven and the flames present is the key to a perfect result.

You can cater to for a lot of people in a short period and at a fraction of the cost. Cooking becomes easy once you have mastered the balance between heat generated from embers (allowing for slow cooking) and flames (more intense heat that roasts). Food that creates a lot of juices like fish, meats, etc., should be cooked in appropriate cookware for the recipe and heat of the oven.

Enjoy your Cr30 oven !