

GT-250 HEAVY-DUTY MULCHER



- Powerful, Reliable 250 HP Cummins STAGE V Turbo Diesel
- NEXUS Touch Command & Control - Real - time, Cloud-based Connectivity: Monitor, Control, Troubleshoot, Diagnose, Communicate and Learn
- Low-profile Fully Enclosed Forward-tilt Cab
- Pressurized Cab w/Comfortable Suspension Seat
- Best in Class, Patented "SABRE TOOTH" Cutting Technology-Pulverizes Wood into Sawdust-like Mulch
- Patented Spiral Tooth Pattern, Creating Vacuum-like Effect
- Dual Control Ribs to Control Cutting Bite, with Knock out Relief and Splitter Point to Expel and Refine Mulch
- Hydraulic Cutter-head Push Bar Extends to Assist Felling Trees
- Six Exterior Lights & 15,000 lb. Winch
- Super Low Ground Pressure Captive Track (as shown), or Aggressive & Rugged Steel Track Options.

ALWAYS THE FIRST, ALWAYS THE BEST

Gyro-Trac introduced the first front attachment with PLANAR teeth & controlled bite RIB in 2003. Gyro-Trac developed the trade name "PLANAR" tooth for mulching. Today, Gyro-Trac is first to introduce the **BEST**, most **ADVANCED** and **PATENTED** cutting technology.

INTERNAL DRIVE MOTOR

US Pat. No. 7,980,278
CA Pat. No. 2,597,973

CONTROLLED BITE

US Pat. No. 7,810,531
US Pat. No. 9,839,914
CA Pat. No. 2,546,294

**LET THE FACTS SPEAK
FOR THEMSELVES!**

MOUNTING ASSEMBLY

US Pat. No. 7,810,531
US Pat. No. 9,839,914
CA Pat. No. 2,546,294

MOUNTING STATION

US Pat. No. 7,810,531
US Pat. No. 9,839,914
CA Pat. No. 2,546,294

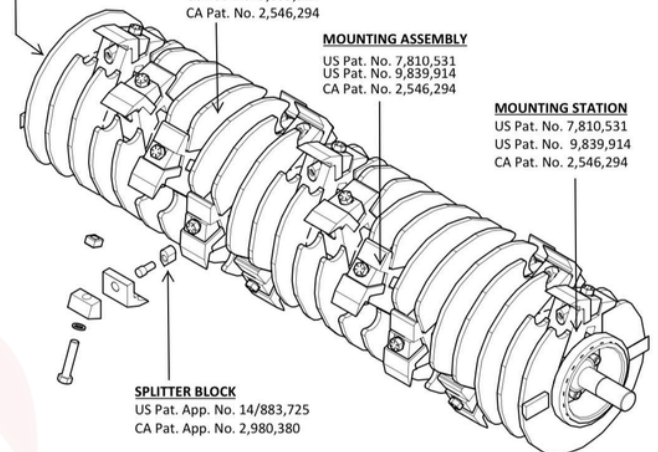

SPLITTER BLOCK

US Pat. App. No. 14/883,725
CA Pat. App. No. 2,980,380

fax: (843) 879-0218 | e: sales@gyrotrac.com

CALL FOR A DEMO TODAY!

www.gyrotrac.com | toll free +1 (866) 800-3900
Copyright © 2023 Gyro-Trac Corporation. All rights reserved.

*Gyro-Trac owns over 20 Patents and Patents Pending, including the above Cutter-head Patents.

SALES@GYROTRAC.COM

GT-250

DEDICATED MULCHER

GENERAL SPECIFICATIONS

	CAPTIVE TRACK	STEEL TRACK
Length	231 in (587 cm)	231 in (587 cm)
Width	102.25 in (260 cm)	102.25 in (259.08 cm)
Height	116 in (295 cm)	124 in (315 cm)
Weight	24,100 lbs (10,932 kg)	30,100 lbs (13,653 kg)
Ground Pressure	3.6 psi (0.25 bar)	4 psi (0.28 bar)
Ground Clearance	13.5 in (34.3 cm)	16 in (40.6 cm)
Maximum Speed	3 mph (4.8 kmh)	3 mph (4.8 kmh)

The GT-250 comes standard with the Nexus Service module, connected to the world's fastest, most advanced cloud-based service platform.

www.gyrotrac.com/NEXUS

UNDERCARRIAGE

CAPTIVE TRACK

3 Belts per track: 6-Ply Rubber
Heat-Treated, 28 in (71 cm) Cross Links:
78 per track, 156 Total
Grease-filled belt Tensioners - 1 @ Each
Track, 4000 psi
4 Tandem, Dual Wheel Carriage Trucks
(2 per side); 16 Wheels Total

STEEL TRACK



Standard Steel Track

ENGINE & FUEL

Make	CUMMINS DIESEL
Model	B6.7, Stage V
Horsepower	250 HP @ 1900 RPM
Torque	875 ft-lbs @ 1300 RPM
Fuel Cons.	12 US gal/hr Max Est
Fuel Capacity	97 US gal (367 ltr)

700HF Cutter-Head

Width	102 in (259 cm)
Depth	34 in (86 cm)
Height	63 in (160 cm)
Weight	5,180 lbs (2,355 kg)
Hyd. Flow up to	75 gpm (284 lpm)
Op. Press. up to	6000 psi (414 bar)

*30 Teeth, 92" (229 cm) cut

STEEL CONSTRUCTED CAB

ROPS - Roll Over Protection System	ISO 8082 & CSA B352.0
FOPS - Falling Object Protection System	ISO 8083 & G608
OPS - Operator Protection System	ISO 8084
Forward Tilt CAB Jack	Raised-CAB electric Motor PUMP
Windows	Lexan MR-10
HVAC System	3-Speed
SEAT	Adjustable suspension w/ armrest & seatbelt

Gyro-Trac is the first Mulching Machine Manufacturer to Offer Stage V Emission Compliant Engines.

Cummins' Single Module After-treatment technology makes engines 50% smaller and 30% lighter than equivalent. Stage IV engines. Stage V's high efficiency NOx conversion has allowed the complete removal of EGR from the engines.

The simpler EGR-free engine platform is more compact, has less weight, fewer parts and is far easier to cool. You get improved reliability with less down time. Simple as that!

SALES@GYROTRAC.COM