

GT-365 HEAVY-DUTY MULCHER



- Powerful, Reliable 365 HP Cummins STAGE V Turbo Diesel
- NEXUS Touch Command & Control-Real-time, Cloud - based Connectivity: Monitor, Control, Troubleshoot, Diagnose, Communicate and Learn
- Low-profile Fully Enclosed Forward - tilt Cab
- Presurized Cab w/Comfortable Suspension Seat
- Best in Class, Patented "SABRE TOOTH" Cutting Technology-Pulverizes Wood into Sawdust-like Mulch
- Patented Spiral Tooth Pattern, Creating Vacuum - like Effect
- Dual Control Ribs to Control Cutting Bite, with Knockout Relief and Splitter Point to Expel and Refine Mulch
- Hydraulic Cutter-head Push Bar Extends to Assist Felling Trees
- Eight Exterior Lights & 30,000 lb. Winch
- Aggressive & Rugged Steel Track Options

ALWAYS THE FIRST, ALWAYS THE BEST

Gyro-Trac introduced the first front attachment with PLANAR teeth & controlled bite RIB in 2003. Gyro-Trac developed the trade name "PLANAR" tooth for mulching. Today, Gyro-Trac is first to introduce the BEST, most ADVANCED and PATENTED cutting technology.

INTERNAL DRIVE MOTOR
Pat. No. 7,980,278
Pat. No. 2,597,973

CONTROLLED BITE
US Pat. No. 7,810,531
US Pat. No. 9,839,914
CA Pat. No. 2,546,294

**LET THE FACTS SPEAK
FOR THEMSELVES!**

MOUNTING ASSEMBLY
US Pat. No. 7,810,531
US Pat. No. 9,839,914
CA Pat. No. 2,546,294

MOUNTING STATION
US Pat. No. 7,810,531
US Pat. No. 9,839,914
CA Pat. No. 2,546,294

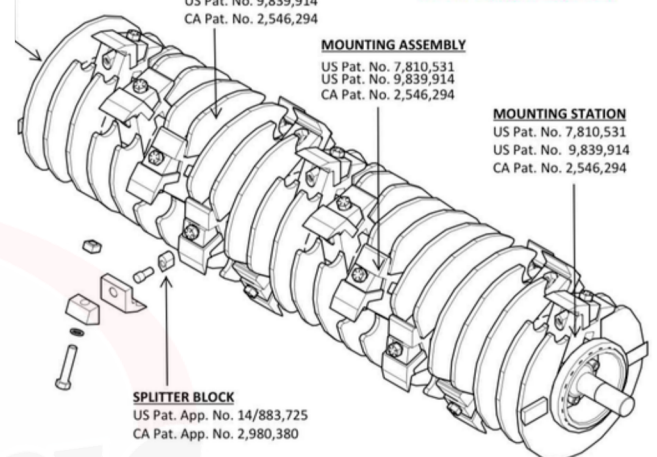

SPLITTER BLOCK
US Pat. App. No. 14/883,725
CA Pat. App. No. 2,980,380

fax: (843) 879-0218 | e: sales@gyrotrac.com

CALL FOR A DEMO TODAY!

www.gyrotrac.com | toll free +1 (866) 800-3900
Copyright © 2023 Gyro-Trac Corporation. All rights reserved.

*Gyro-Trac owns over 20 Patents and Patents Pending, including the above Cutter-head Patents.

SALES@GYROTRAC.COM

GT-365

DEDICATED MULCHER

GENERAL SPECIFICATIONS

Cutter-Head	765HF
Length	246 in (625 cm)
Width	102 in (259 cm)
Height	125.25 in (318 cm)
Weight	37,000 lbs (16,783 kg)
Ground Pressure	4.8 psi (0.33 bar)
Ground Clearance	16.2 in (41.2 cm)
Maximum Speed	3.5 mph (5.63 kmh)
Teeth	30 teeth, 92" (229cm) cut

The GT-365 comes standard with the Nexus Service module, connected to the world's fastest, most advanced cloud-based service platform.

www.gyrotrac.com/NEXUS

HYDRAULICS

Mulcher Circuit	107 gpm @ 6000psi (405 lpm @ 414bar)
Hydraulic Tank Capacity	47 gals (178 ltrs)
Automatic Hydraulic Reversible Fan	

UNDERCARRIAGE

Rollers	2 top / 9 bottom
Width	28" (71cm)
Single Grouser	

ENGINE

Make	CUMMINS DIESEL	DEF Cons.	1.2-1.3 US gal/hr Max. Est.
Model	L9, Stage V	DEF Tank Capacity	15 gals (57 ltrs)
Horsepower	365 HP @ 2100 RPM	Electrical System	12V
Torque	1151 ft-lbs @ 1400 RPM	Battery	Dual 12V
Fuel Cons.	12-13 US gal/hr.	After Treatment	Stage V
Fuel Capacity	125 US gal. (473 ltr)		

STEEL CONSTRUCTED CAB

Forward Tilt CAB Jack	Raised-CAB electric Motor PUMP
Windows	Lexan MR-10 1/2"
HVAC System	3-Speed
Seat	Adjustable suspension w/ armrest & seatbelt
Pressurized Cab	Rear view Camera

SALES@GYROTRAC.COM