

# 700 HF HEAVY-DUTY CUTTER-HEAD

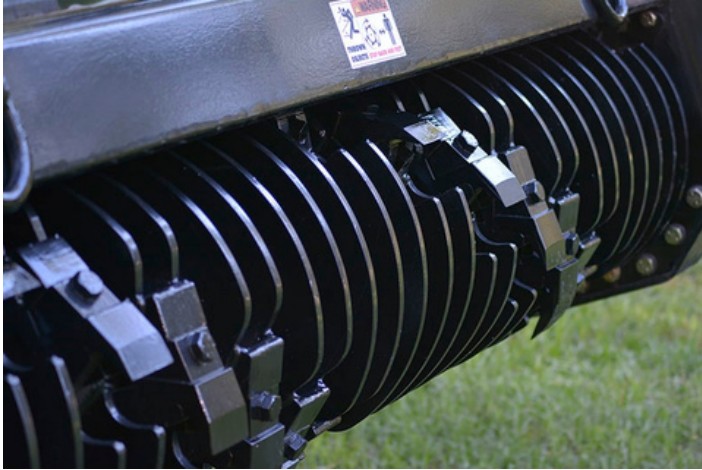

## FRONT



## AT WORK



## DIMENSIONS

Cutting Width	92 in (229 cm)
Width	102 in (259 cm)
Depth	34 in (86 cm)
Height	63 in (160 cm)
Weight	5180 lbs. (2355 kg)

## SPECIFICATIONS

No. of Teeth	30 TEETH
Hyd. Flow up to	120 gpm (454 lpm)
Oper. Pressure up to	6000 psi (413 bar)

## CASE DRAIN RETURN PRESSURE

Maximum (continuous)	43 psi. (3 bar)
Intermittent (Cold Start)	73 psi. (5 bar)

**The 700-HF HDM is Gyro-Trac's Largest, Most Powerful Cutter-head, for use on High Horse-power Prime Movers on Wheels or Tracks.**

### ***ALWAYS THE FIRST, ALWAYS THE BEST***

Gyro-Trac introduced the first front attachment with PLANAR teeth & controlled bite RIB in 2003. Gyro-Trac developed the trade name "PLANAR" tooth for mulching. Today, Gyro-Trac is first to introduce the **BEST**, most **ADVANCED** and **PATENTED** cutting technology.

### **INTERNAL DRIVE MOTOR**

US Pat. No. 7,980,278  
CA Pat. No. 2,597,973

### **CONTROLLED BITE**

US Pat. No. 7,810,531  
US Pat. No. 9,839,914  
CA Pat. No. 2,546,294

**LET THE FACTS SPEAK  
FOR THEMSELVES!**

### **MOUNTING ASSEMBLY**

US Pat. No. 7,810,531  
US Pat. No. 9,839,914  
CA Pat. No. 2,546,294

### **MOUNTING STATION**

US Pat. No. 7,810,531  
US Pat. No. 9,839,914  
CA Pat. No. 2,546,294

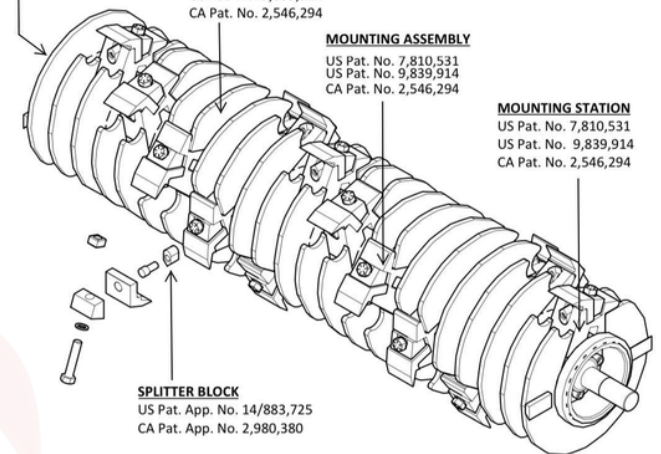

### **SPLITTER BLOCK**

US Pat. App. No. 14/883,725  
CA Pat. App. No. 2,980,380

ph: (843) 879-0208 | Fax: (843) 879-0218 | e: sales@gyrotrac.com

**CALL FOR A DEMO TODAY!**

www.gyrotrac.com | toll free +1 (866) 800-3900  
Copyright © 2023 Gyro-Trac Corporation. All rights reserved.

\*Gyro-Trac owns over 20 Patents and Patents Pending, including the above Cutter-head Patents.

# SALES@GYROTRAC.COM

# 700 HF **HEAVY-DUTY** CUTTER-HEAD

## ABOUT THE MACHINE

Gyro-Trac's **SABRE-TOOTH TITAN** cutting technology PULVERIZES Wood into Sawdust-like Mulch. The new **SABRE-TOOTH** design is the NEXT GENERATION of "disruptive technology", improving on Gyro-Trac's Planar tooth.

It begins with a **WIDER TOOTH**, held in place with a **WEDGED FRICTION BLOCK**, taking all the force off of the single bolt . **THAT'S RIGHT!** Only one bolt to quickly and easily replace worn teeth.

The **CONTROLLED BITE** is now achieved with **TWO** instead of one control rib under the tooth. The distance between control ribs is wider.

The **KNOCK-OUT RELIEF** that reduces resistance by allowing the wood chip to curl into the relief, now has a **SPLIT BLOCK** strategically placed to **SPLIT THE CHIP** and further **REDUCE** the size of the wood chip. This new design creates a **SELF-CLEANING** effect, clearing the tooth for the next bite.

*SABRE-TOOTH TITAN cutting technology PULVERIZES Wood into Sawdust-like Mulch*

With a perfectly tuned hydraulic recipe you can now understand how Gyro-Trac machines can **mulch more wood with Less Weight, Less Energy and Less Fuel** than any of our competitors. You can also understand how the smallest mulch in the business leaves behind that famous, Gyro-Trac "Park-Like effect", and the fine, rapidly biodegradable mulch just simply Won't Wick Fire, making a Gyro-Trac *the perfect machine for cutting fire breaks.*

**SALES@GYROTRAC.COM**