

500HFHDM GT

CUTTER-HEAD



FRONT



2X POWER



Optional 2nd Drive Motor = 2X Power

ph: (843) 879-0208 | Fax: (843) 879-0218 | e: sales@gyrotrac.com

CALL FOR A DEMO TODAY!

www.gyrotrac.com | toll free +1 (866) 800-3900
Copyright © 2023 Gyro-Trac Corporation. All rights reserved.

DIMENSIONS

Cutting Width	65 in (165 cm)
Width	80.75 in (205 cm)
Depth	34.5 in (88cm)
Height	53 in (135 cm)
Weight	3842 lbs. (1742 kg)

SPECIFICATIONS

No. of Teeth	22 TEETH
Hyd. Flow up to	50 gpm (189 lpm)
Oper. Pressure up to	6000 psi (413 bar)

CASE DRAIN RETURN PRESSURE

Maximum (continuous)	43 psi. (3 bar)
Intermittent (Cold Start)	73 psi. (5 bar)

The 500-HF HDM is the standard Cutter-head for Heavy Duty Excavators. It Quickly Converts for use on Skid Steers and Compact Track Loaders.

ALWAYS THE FIRST, ALWAYS THE BEST

Gyro-Trac introduced the first front attachment with PLANAR teeth & controlled bite RIB in 2003. Gyro-Trac developed the trade name "PLANAR" tooth for mulching. Today, Gyro-Trac is first to introduce the BEST, most ADVANCED and PATENTED cutting technology.

INTERNAL DRIVE MOTOR

US Pat. No. 7,980,278
CA Pat. No. 2,597,973

CONTROLLED BITE

US Pat. No. 7,810,531
US Pat. No. 9,839,914
CA Pat. No. 2,546,294

LET THE FACTS SPEAK FOR THEMSELVES!

MOUNTING ASSEMBLY

US Pat. No. 7,810,531
US Pat. No. 9,839,914
CA Pat. No. 2,546,294

MOUNTING STATION

US Pat. No. 7,810,531
US Pat. No. 9,839,914
CA Pat. No. 2,546,294

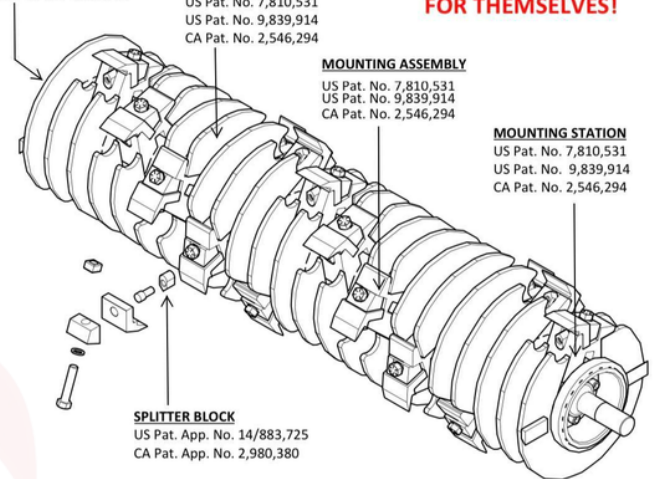

*Gyro-Trac owns over 20 Patents and Patents Pending, including the above Cutter-head Patents.

SALES@GYROTRAC.COM

500 HF **HDM** CUTTER-HEAD

ABOUT THE MACHINE

Gyro-Trac's **SABRE-TOOTH TITAN** cutting technology PULVERIZES Wood into Sawdust-like Mulch. The new **SABRE-TOOTH** design is the NEXT GENERATION of "disruptive technology", improving on Gyro-Trac's Planar tooth.

It begins with a **WIDER TOOTH**, held in place with a **WEDGED FRICTION BLOCK**, taking all the force off of the single bolt . **THAT'S RIGHT!** Only one bolt to quickly and easily replace worn teeth.

The **CONTROLLED BITE** is now achieved with **TWO** instead of one control rib under the tooth. The distance between control ribs is wider.

The **KNOCK-OUT RELIEF** that reduces resistance by allowing the wood chip to curl into the relief, now has a **SPLIT BLOCK** strategically placed to **SPLIT THE CHIP** and further **REDUCE** the size of the wood chip. This new design creates a **SELF-CLEANING** effect, clearing the tooth for the next bite.

SABRE-TOOTH TITAN cutting technology PULVERIZES Wood into Sawdust-like Mulch

With a perfectly tuned hydraulic recipe you can now understand how Gyro-Trac machines can **mulch more wood with Less Weight, Less Energy and Less Fuel** than any of our competitors. You can also understand how the smallest mulch in the business leaves behind that famous, Gyro-Trac "Park-Like effect", and the fine, rapidly biodegradable mulch just simply Won't Wick Fire, making a Gyro-Trac *the perfect machine for cutting fire breaks.*

SALES@GYROTRAC.COM