

GT-200 MEDIUM-DUTY MULCHER



- Powerful, Reliable 200 HP Cummins Stage V Turbo Diesel
- Fully Enclosed Forward - tilt Cab with LED lights
- Comfortable Suspension Seat
- Best in Class, Patented "SABRE TOOTH" Cutting Technology - Pulverizes Wood into Sawdust - Like Mulch
- Patented Spiral Tooth Pattern, Creating Vacuum - Like Effect
- Dual Control Ribs to Control Cutting Bite with Knockout Relief and Splitter Point to Expel and Refine Resulting Mulch
- Hydraulic Cutter-head Push Bar Extends to Assist Felling Trees
- 15,000 lb Winch

ALWAYS THE FIRST, ALWAYS THE BEST

Gyro-Trac introduced the first front attachment with PLANAR teeth & controlled bite RIB in 2003. Gyro-Trac developed the trade name "PLANAR" tooth for mulching. Today, Gyro-Trac is first to introduce the **BEST**, most **ADVANCED** and **PATENTED** cutting technology.

INTERNAL DRIVE MOTOR

US Pat. No. 7,980,278
CA Pat. No. 2,597,973

CONTROLLED BITE

US Pat. No. 7,810,531
US Pat. No. 9,839,914
CA Pat. No. 2,546,294

**LET THE FACTS SPEAK
FOR THEMSELVES!**

MOUNTING ASSEMBLY

US Pat. No. 7,810,531
US Pat. No. 9,839,914
CA Pat. No. 2,546,294

MOUNTING STATION

US Pat. No. 7,810,531
US Pat. No. 9,839,914
CA Pat. No. 2,546,294

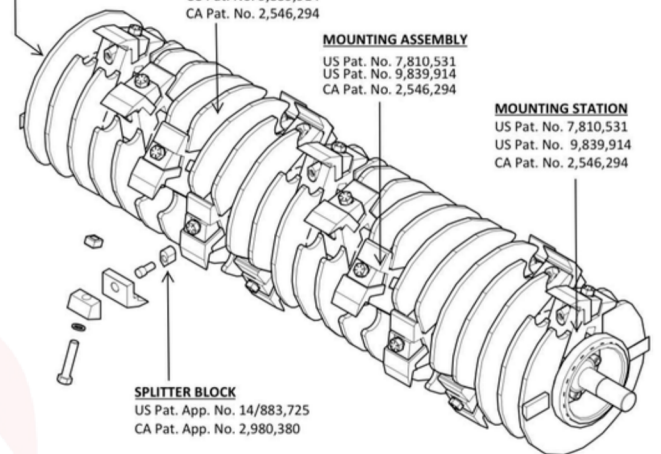

SPLITTER BLOCK

US Pat. App. No. 14/883,725
CA Pat. App. No. 2,980,380

fax: (843) 879-0218 | e: sales@gyrotrac.com

CALL FOR A DEMO TODAY!

www.gyrotrac.com | toll free +1 (866) 800-3900
Copyright © 2023 Gyro-Trac Corporation. All rights reserved.

*Gyro-Trac owns over 20 Patents and Patents Pending, including the above Cutter-head Patents.

SALES@GYROTRAC.COM

GT-200

DEDICATED MULCHER

GENERAL SPECIFICATIONS

Cutter-Heads	516HF	616HF
Length	194.50 in (494 cm)	190 in (483 cm)
Width	80.75 in (205 cm)	92.25 in (234 cm)
Height	121 in (307 cm)	
Weight	17,660 lbs (8010 kg)	18,000 lbs (8165 kg)
Ground Pressure	5.2 psi per SAE J1309 (0.36 bar)	
Ground Clearance	16 in (41 cm)	
Maximum Speed	5 mph (8 km/h)	
Teeth	22 teeth, 65" (165cm) cut	26 teeth, 75-1/2" (192cm) cut

The GT-200 comes standard with the Nexus Service module, connected to the world's fastest, most advanced cloud-based service platform.

www.gyrotrac.com/NEXUS

HYDRAULICS

Mulcher Circuit	58 gpm @ 6000 psi	220 lpm @ 414 bar
Hydraulic Tank Capacity	30 gallons	114 liters
Automatic Hydraulic Reversible Fan		

TRACK

Rollers	2 top / 6 bottom
Width	17-3/4"
Triple Grouser	

ENGINE

Make	CUMMINS DIESEL	After Treatment	Stage V
Model	B4.5, Stage V	DEF Cons.	0.4-0.5 gph (1.5-1.9 lph)
Horsepower	200 HP	DEF Tank Capacity	10 gals (38 ltrs)
Torque	576 ft-lbs (780N-m)	Electrical System	12V
Fuel Cons.	6-7 US gal/hr	Battery	Dual 12V
Fuel Capacity	67 US gal. (254 ltr)		

STEEL CONSTRUCTED CAB

Forward Tilt Cab Jack	Raised-Cab Electric Motor Pump
Windows	1/2 in. Lexan MR-10
HVAC System	3-Speed
Pressurized Cab	Rear view camera
Seat	Adjustable suspension w/ armrest & seatbelt

The GT-200 utilizes the same Cutter-head mounting system that the GT-365 uses, creating a power mulcher in a smaller footprint.

SALES@GYROTRAC.COM