

PEARL®

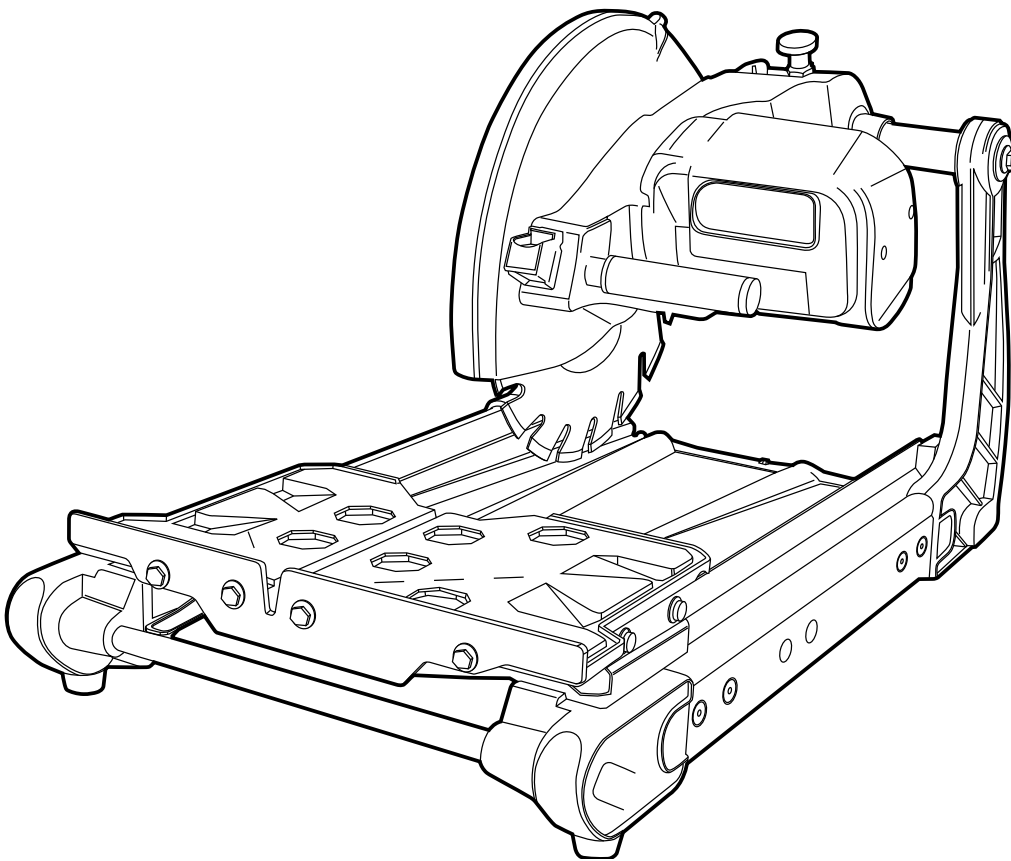

MODEL VX141MS™
MASONRY/BRICK SAW
OWNER'S/OPERATOR'S MANUAL



SERIAL NUMBER -

*You should record the Serial Number of your Saw on this Owner's/Operator's Manual and on the Warranty Card. **The Warranty Card must be sent back with all the required pertinent information for the warranty to take effect.***

Caution! *Read Safety and General Instructions carefully before using saw for the first time.*

REV. 2

PEARL ABRASIVE CO. MASONRY SAW



TABLE OF CONTENTS

	PAGE
I. GENERAL SAFETY RULES FOR ALL POWER TOOLS.....	3
II. SYMBOLS	4
III. FEATURES.....	5
IV. SPECIFICATIONS.....	5
V. UNPACKING	6
VI. INSTALLATION AND OPERATION	6
VII. PROPER BLADE USE	8
VIII. CARBON BRUSH REPLACEMENT.....	8
IX. AIR FILTER	9
X. CARE AND MAINTENANCE	9
XI. REPLACEMENT PARTS LIST	10
XII. ACCESSORIES AND PARTS	10
XIII. ELECTRICAL MOTOR SPECIFICATIONS	12
XIV. WATER HOSE KIT INSTALLATION	12
XV. TROUBLESHOOTING.....	13
XVI. THE RIGHT BLADES DOES THE RIGHT JOB.....	15
XVII. HOW TO ORDER PARTS.....	15

i. GENERAL SAFETY RULES FOR ALL POWER TOOLS



WARNING! *Read all instructions. As with all machinery there are certain hazards involved with operation and use of the machine. The following basic safety precautions should be followed at all times to reduce the risk of fire, electric shock and serious personal injury to you or others. Keep these important operating instructions with this product.*



1. Know your power tool - read owner's/operator's manual carefully. Learn its applications and limitations as well as the specific potential hazards unique to this tool.



2. Keep guards in place - and in working order.

3. Ground all tools - if tools are equipped with three prong plug, it should be plugged into a three-hole electrical receptacle. If an adapter is used to accommodate a two-prong receptacle, the adapter lug must be attached to a known ground. Never remove the third prong.



4. Remove wrenches - Form a habit of checking to see that adjusting wrenches are removed from tool before turning it "on".



5. Keep work area clean. Cluttered areas and benches invite accidents.

6. Do not use in dangerous environment. Do not use power tools in damp or wet locations, or expose them to rain. Keep work area well lighted. Do not use tool in the presence of flammable liquids or gasses.



7. Keep children and visitors away. All children and visitors should be kept at a safe distance from work area.

8. Make workshop childproof with padlocks, master switches or by removing starter keys.

9. Do not force tool. It will do the job better and be safer at the rate for which it was designed.

10. Use right tool. Do not force tool or attachment to do a job for which it was not designed.



11. Wear proper apparel. Do not wear loose clothing, gloves, neckties, rings, bracelets or other jewelry that may get caught in moving parts. Non-slip footwear is recommended. Wear protective hair covering to contain long hair.



12. **Always use safety glasses.** Wear safety glasses (must comply with ANSI Z87.1) at all times. Everyday eyeglasses only have impact resistant lenses; they are not safety glasses. Use face or dust mask if cutting operation is dusty, and ear protectors (plugs or muffs) during extended periods of operation.



13. Do not overreach. Keep proper footing and balance at all times.



14. Maintain tools in top condition. Keep tools sharp and clean for best and safest performance. Follow instructions for lubricating and changing accessories. Inspect tool cords periodically and if damaged, have repaired by authorized service facility.



15. Disconnect tools. When not in use, before servicing, and when changing accessories, such as blades, bits, cutters.



16. Avoid accidental starting. Make sure switch is in "off" position before plugging in power cord.

17. Use recommended accessories only. Consult the owner's manual for recommended accessories. The use of improper accessories may cause risk of injury to persons.



18. Never stand on tool. Serious **injury** could occur if the tool is tipped or if the cutting tool is accidentally contacted.



19. Check Damaged Parts. Before further use of the tool, a guard or other part that is damaged should be carefully checked to ensure that it will operate properly and perform it's intended function. Check for alignment of moving parts, binding of moving parts, breakage of parts, mounting, and any other conditions that may affect it's operation. A guard or part that is damaged should be properly repaired or replaced.

20. Never leave tool running unattended. Turn power "off". Do not leave tool until it comes to a complete stop.

21. Extension cords. Make sure your extension cord is in good condition. When using an extension cord, be sure to use one heavy enough to carry the current your product will draw. An undersized cord will cause a drop in line voltage resulting in loss of power and overheating. Extension cord tables (*refer to page 12*) show the correct size to use depending on cord length and nameplate ampere rating. If in doubt, use the next heavier gauge. The smaller the gauge numbers the heavier the cord.

22. Do not abuse cord. Never carry tool by cord or pull it to disconnect from receptacle. Keep cord from heat, oil, and sharp edges.

23. Guard against electric shock. Prevent body contact with grounded surfaces. For example, pipes, radiators, ranges and refrigerator enclosures.

24. Outdoor use extension cords. When tool is used outdoors, use only extension cords intended for use outdoors and so marked.

25. Stay alert. Watch what you are doing. Use common sense. Do not operate tool when you are tired.

26. Drugs, alcohol, medication. Do not operate tool while under the influence of drugs, alcohol or any medication.

27. Store idle tool. When not in use, tool should be stored in a dry and locked place, out of reach of children.



WARNING! *CALIFORNIA PROPOSITION 65: Sawing and drilling generates dust. Excessive airborne particles may cause irritation to eyes, skin and respiratory tract. To avoid breathing impairment always employ dust controls and protection suitable to the material being saw or drilled in accordance with OSHA (29 CFR Part 1910.1). Diamond blades improperly used are dangerous. Comply with ANSI Safety Code B7.1 and OSHA covering speed, safety guards, flanges, mounting procedures, general operating rules, handling, storage and general machine condition.*

ii. SYMBOLS



KEEP GUARD IN PLACE



REPAIRS TO BE DONE



WEAR HEARING PROTECTION



DIAMOND BLADE



MACHINE HAZARD



WEAR EYE PROTECTION



BLADE CUTTING DEPTH



FLAMMABLE



WEAR BREATHING PROTECTION



ELECTRIC SWITCH OFF



READ INSTRUCTIONS CAREFULLY



WEAR HARD HAT



ELECTRIC SWITCH ON



WARNING



WEAR PROTECTIVE CLOTHING



ELECTRICAL HAZARD



FRAGILE



WEAR SAFETY SHOES



REMOVE TOOLS



KEEP DRY

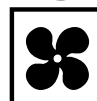

WELL VENTILATED



PAY EXTREME ATTENTION



DO NOT STEP ON



NO NON-WORKING PERSONNEL

iii. FEATURES

The VX141MS Masonry saw is designed for the professional contractor in mind. It enhances performance with a multitude of features facilitating operation.

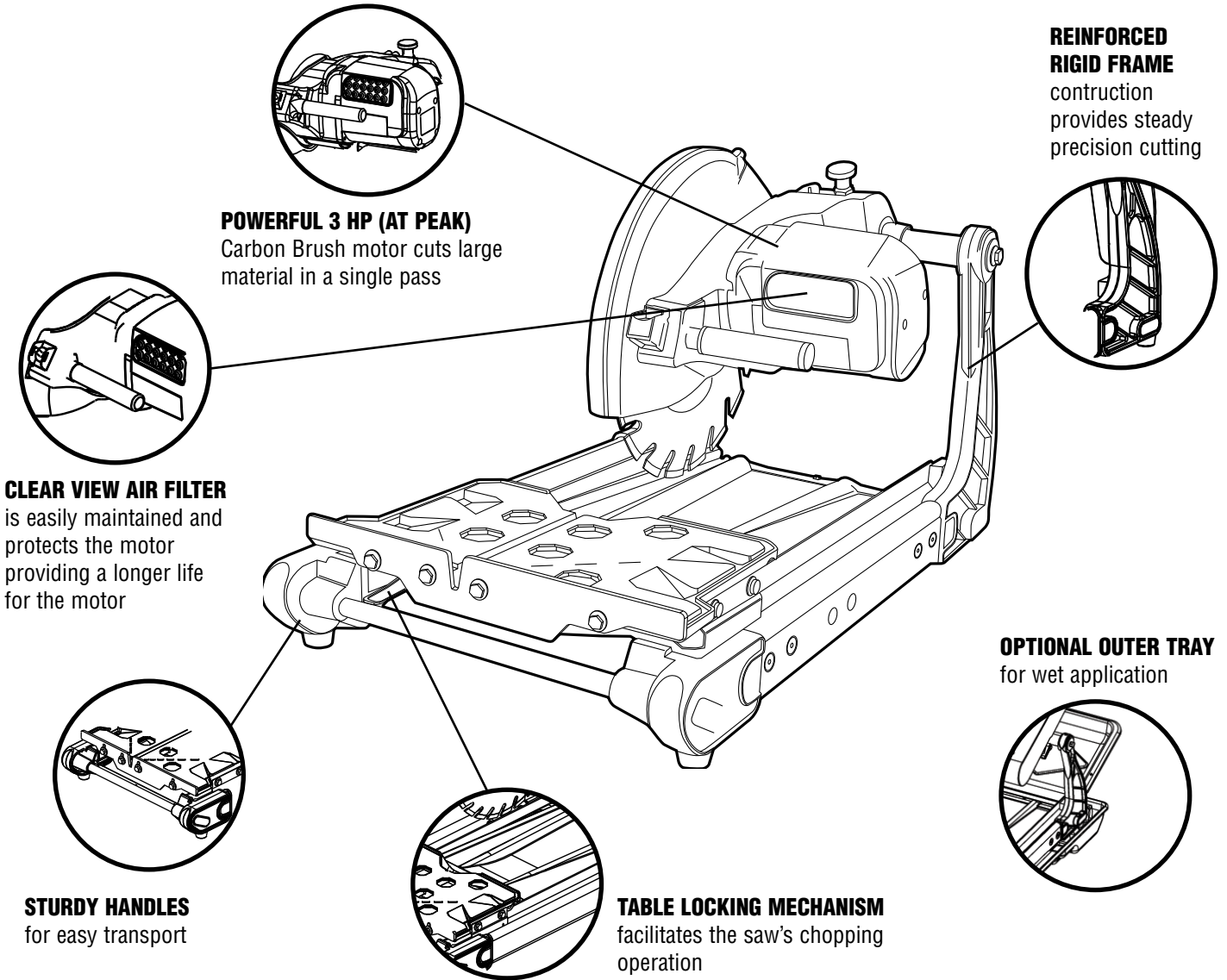

iv. SPECIFICATIONS

VX141MS MASONRY/BRICK SAW					
MOTOR	MAX. BLADE CAPACITY	CUTTING LENGTH	CUTTING DEPTH	WEIGHT	SIZE
3 HP Peak 115 v, 60 Hz, 3,600 rpm	14" blade with 1" (25.4mm) arbor	16" Max material size 8 x 8 x16"	5"	75 lbs. uncrated	31.5 x 18.5 x 19"

v. UNPACKING

Open the container. Carefully lift the saw out evenly by the frame. Be certain you have the following items before you discard the container:

- Saw
- Extra air filter
- 14" saw blade
- 45°/90° rip guide
- Universal wrench
- Owner's manual

vi. INSTALLATION AND OPERATION

BLADE INSTALLATION

1. Move the blade shaft cover upwards. To remove the blade lock nut, open the shaft space. *Figure 1.*
2. Place the 14" blade onto the blade shaft. Make sure that the directional arrow is pointing in the direction of the shaft rotation.
3. Lock the blade lock nut with the outer flange. Use the multiple wrench provided to fasten the blade tightly.

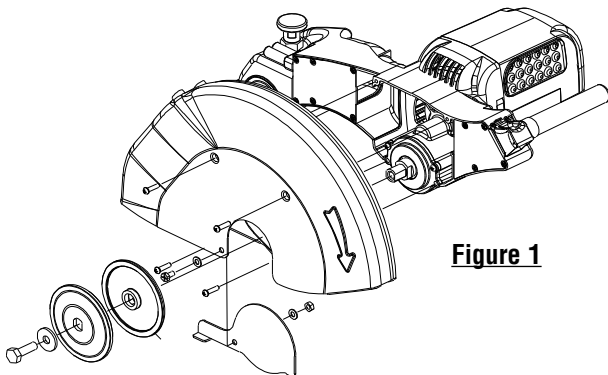

Figure 1

CUTTING TABLE ASSEMBLY

To install the cutting table to the machine:

1. Set the cutting table on the rails. *Figure 2.*
2. Install the screws and brackets to the cutting table.
3. To remove the cutting table, do the reverse of the above two steps.

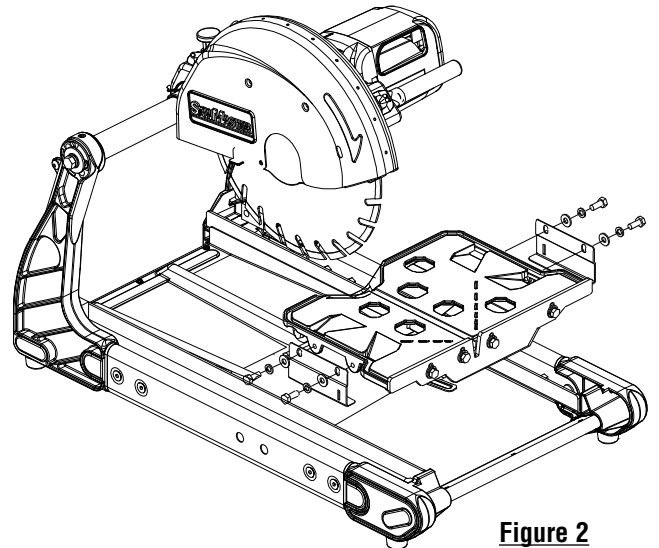

Figure 2

THE CUTTING TABLE

The heavy-duty cutting table provides the durability to handle large materials. *Figure 3.*

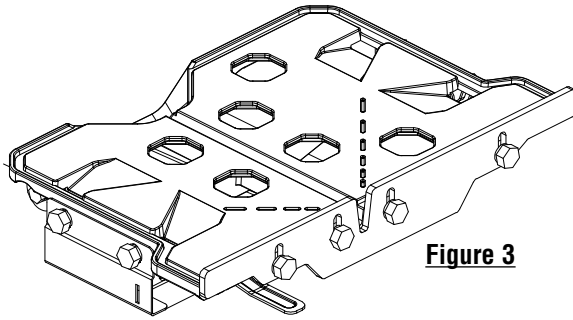

Figure 3

WARNING: Only use the 14" diameter blade for this saw. Setting smaller size of diamond blade may grab the material being cut, causing damage and possibly injury.

STEPS TO USE THE 45° / 90° RIP GUIDE

1. Set the rip guide by positioning it on the desired dimension and tighten the threaded knob. Make sure that the rip guide is firmly tightened to avoid slippage. The rip guide can be used 90° rip cuts and 45° angle cuts from both the left and right side. (Note: The straight and 45° angled slits on the bottom of the rip guide.)
2. After the rip guide is positioned for the desired cut, place material flat against the rip guide and the measurement rail. For the 45° rip cuts, place the corner of material in the open slot of the measurement rail.
3. Simply line up the material being cut with the appropriate pre-marked lines on the cutting table.
4. Now you are ready to make your cut.

CUTTING DEPTH

The recommended cutting depth is 1/4" below the cutting table surface. When setting the cutting depth, do a practice pass with the table to make sure the blade does not cut into it.

Blade Diameter	Cutting Depth
14"	5 inch

WARNING: It is recommended to cut all the way through the material being cut. Failure to do so can result in the diamond blade grabbing the material causing damage and possibly injury.

THE SPRING LOCK PIN

The VX141MS Masonry Saw is designed with three different cutting heights for jam cutting, a moving head for chop (or plunge cutting), and a moving cart combined with the moving head for step cutting to help make any cutting task easier.

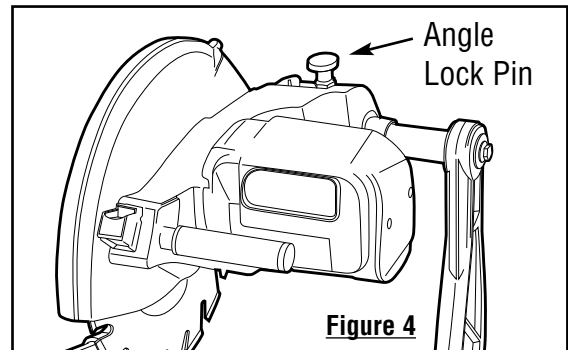

Figure 4

1. Before adjusting the cutting depth always disconnect the electrical power supply.
2. To adjust the saw's fixed cutting position, pull up on the Angle Lock Pin, *Figure 4*, move the head to the new position, release the Angle Lock Pin, and rotate the cutting head up/down until the Angle Lock Pin locks into position (lowest position for cutting thru bricks). The middle position is for cutting block and the upper position for blade replacement.

CHOP / PLUNGE SAW OPERATION

To operate the VX141MS as a chop or plunge saw: pull up on the Angle Lock Pin, rotate 90 degrees, and release. Now the cutting head can be rotated by pulling up or pushing down on the cutting head handle. When not in use, always lock the head into one of the three cutting height positions.

HEAD POSITION	APPLICATION
Fixed Lowest	Jam cutting bricks
Fixed Middle	Jam cutting block
Fixed Upper	Diamond blade replacement
Moving	Chop or Plunge Cutting
Moving head with moving table	Step cutting

vii. PROPER BLADE USE

DO'S

- Inspect blades daily for cracks or uneven wear.
- Always use appropriate blade for material being cut.
- Inspect arbor shaft for uneven wear before mounting blade.
- Always use blades with the correct arbor shaft size.
- Ensure that blade is mounted in the correct direction.
- Use proper safety equipment when operating the saw.
- Secure the blade to the arbor with a wrench.
- Periodically check the blade for cracks or bond fatigue.
- In addition to the following, always follow wet recommendations.
- Use appropriate blade for material being cut.
- Inspect segment blades for segment cracking or loss.
- Do not use damaged blades.
- Use proper safety equipment when operating the saw.

DON'TS

- Do not operate the saw without safety guards in position.
- Do not operate the saw with blades larger than 14".
- Do not cut dry with blades marked "Use Wet".
- Do not exceed manufacturer's recommended maximum RPM.
- Do not force blade into material. Let blade cut at its own speed.
- In addition to the following, always follow wet recommendations.
- Do not make long cuts with dry blades. Allow them to air cool.
- Do not use the edge or side of blade to cut or grind.
- Do not attempt to cut a radius or curve.
- Do not cut too deep or too fast into the material.
- Do not cut any material not recommended by blade manufacturer.

viii. CARBON BRUSH REPLACEMENT

The VX141MS Masonry Saw uses a high horsepower low amperage air cooled brush motor. Replace the carbon brushes when the motor begins to loose power. Brushes typically need to be replaced during the life of the saw. Replace the brushes when over 2/3 of their original length is used (when the overall length of the brush is less than 7/16" (11.1 mm). It is normal for the brushes to wear down.

To replace the carbon bursh, perform the following steps:

1. Disconnect the electrical supply.
2. Remove the air filter.
3. Remove the four (4) motor air in-take cover mounting screws. *See Figure 5A.*
4. Remove the motor air in-take from the motor.

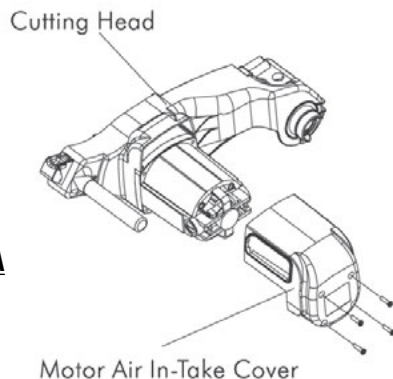

Figure 5A

5. Use a coin or wide blade screw driver to remove the carbon brush cap. Use care not to damage the carbon brush cap. Inste the cap for damage. If the cap has any signs of damage, replace. *See Figure 5B.*

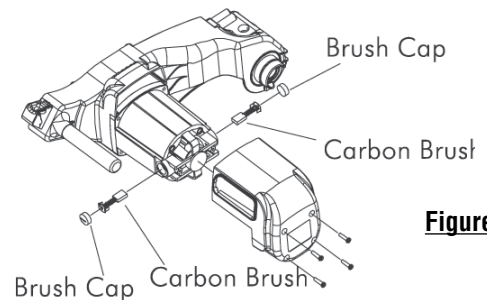

Figure 5B

6. Remove the carbon brush.
7. Use the compressed air to blow any access carbon build up out of the motor.
8. Inspect the inside of the motor by looking into the brush holder for any excessive wear or carbon build-up.
9. Place the new carbon brush.
10. Replace the carbon brush cap and tighten the cap with a coin or wide blade screw driver. Only snug the cap down. Over tigthening the cap can cause damage to the cap.
11. Reinstall the motor air in-take cover and re-attach the four mounting screws. Do not over tighten.
12. Clean the air filter.
13. Re-install the air filter.

ix. AIR FILTER

The VX141MS Masonry Saw is equipped with a specially designed air filter to help protect the motor from the damage due to high speed dust intake during operation.

AIR FILTER REPLACEMENT

To replace the air filter, perform the following steps:

1. Carefully removed the old air filter from the motor air in-take cover opening. Note: Pull the air filter thru the opening in the front of the motor air in-take cover.
2. Inspect the new air filter for damage.
3. Place the new air filter into the motor air in-take cover.
4. The air filter should fill the opening in the front of the air in-take cover and should completely fill the filter cavity.

 **WARNING: Using the machine with a dirty, damaged, or missing air filter will result in motor damage and is not covered under warranty.**

CLEANING THE AIR FILTER

To clean the air filter, perform the following steps:

1. Carefully removed the old air filter.
2. Clean the air filter by patting, and shaking the dust from the filter. It also be cleaned with water. After clean dry before replace the air in-take. Compressed air can be used to blow the dust out of the filter.
3. Inspect the filter for damage. Any damaged air filter must be replaced before using the machine.
4. Replace the filter into the motor air in-take.
5. Check to see if the air filter is installed properly. The air filter should fill the opening in the front of the air in-take cover and should completely fill the filter cavity.

x. CARE AND MAINTENANCE

 **WARNING: For your safety before performing any maintenance on the saw turn off the power switch and unplug the power cord.**

CLEANING

AFTER EVERY USE OF THE MACHINE:

- Remove dirty water from container.
- Remove dirt and mud from the bottom of the container

AFTER WET CLEANING AND BEFORE USING THE MACHINE AGAIN:

- Connect the machine to an electric power outlet equipped with a GFCI safety power breaker. If the safety power breaker cuts off the electrical power supply, do not try to operate the machine but have it checked by an authorized dealer first.

BEFORE AND AFTER A PROLONGED TIME:

- After not using the machine for a prolonged period of time, clean and lubricate all movable parts.
- Check that the saw is sitting properly on the folding stand.
- Check that all the screw joints and nuts are fixed.
- Check that the roller table is in its guides and that is easily moves to and from.
- With the saw blade removed, switch on the motor for an instant and switch it off again. If the motor does not run, have the machine inspected by a qualified electrician.

xi. REPLACEMENT PARTS LIST

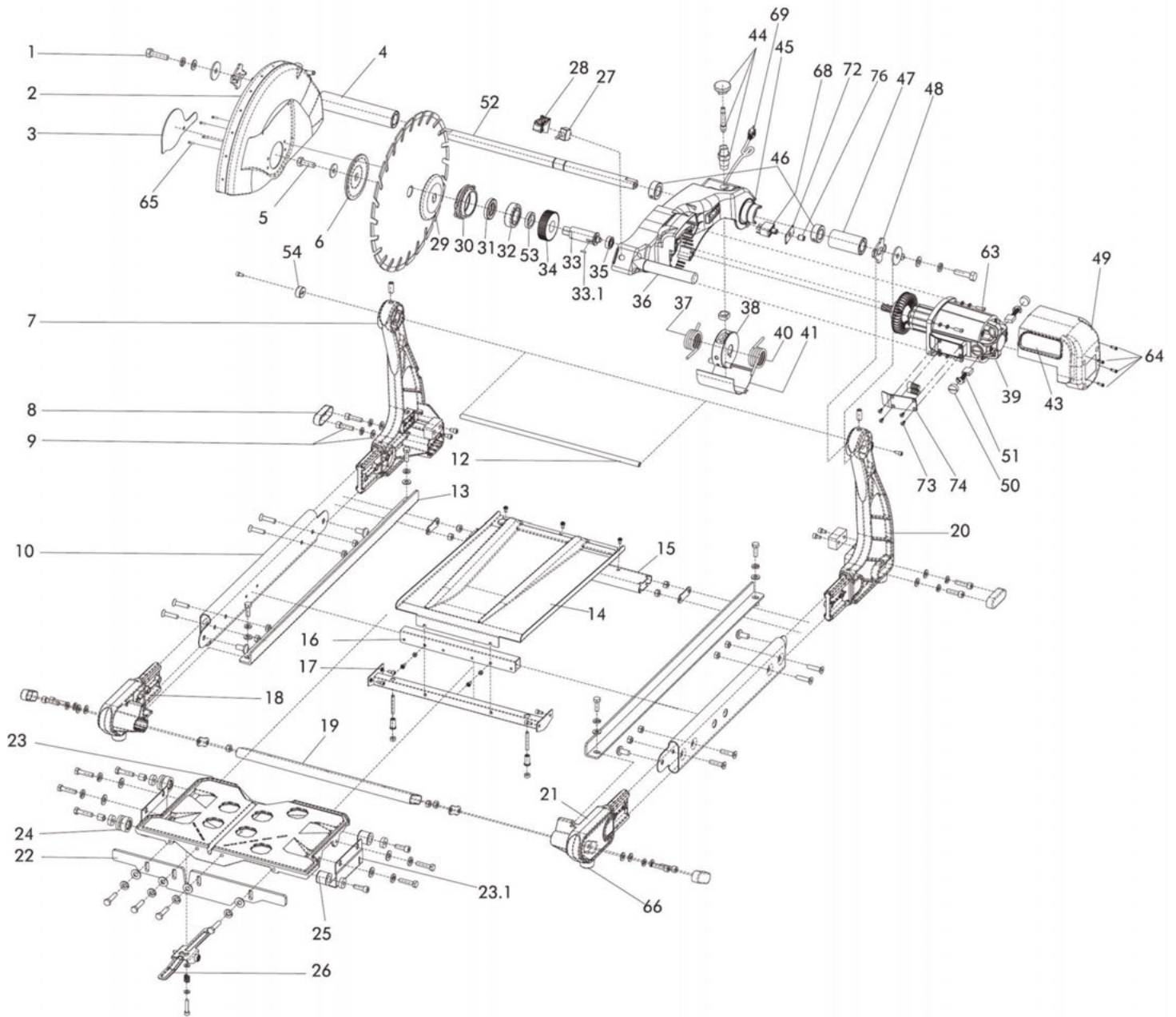

xii. ACCESSORIES & PARTS

Name (Qty.)
Complete 45°/90° Rip Guide with Knob (1)
Part Number
V35000

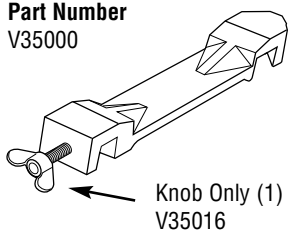

Name (Qty.)
(Optional) Master Guide (1)
Part Number
V370064

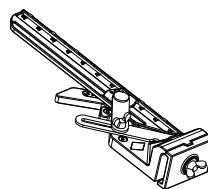

Name (Qty.)
(Optional) Angle Guide (1)
Part Number
V370060

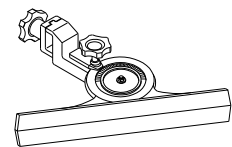

PART NAME	PART NUMBER	PART NAME	PART NUMBER
1 Screw M10XP1.5X20L	V390001	33 Blade Shaft BBM/YMN307	V390033
2 Blade Guard	V390002	33.1 Key Woodruf	V390033.1
3 Arbor Cover BBM/YBM307	V390003	34 Gear Blade shaft	V390034
4 Cross Bar Position Tube (Long) 2	V390004	35 Bearing Motor Inner	V390035
5 Blade Lock Bolt M10X20 1.25 DIN933	V390005	36 Handle Bar	V390036
6 Outer Flange	V390006	37 Tension Spring Left Side	V390037
7 Arm Frame, Left Side	V390007	38 Cutting Head Angle Main Bracket	V390038
8 Rubber Cap	V390008	39 Complete Motor	V390062M
9 Bolt & Washer (3 pieces)	V390009	40 Tension Spring Right Side	V390040
10 Side Frame (1)	V390010	41 Spring Housing Cover	V390041
12 Dry Kit Cross Bar	V390012	43 Air Filter	V390043
13 Sliding Rail (2)	V390013	44 Angle Adjustment Lock Pin	V390044
14 Dust Collecting Pan	V390014	45 Cutting Head Casting Only	V390045
15 Cross Tub	V390015	46 Collar Set Cutting Head	V390046
16 Metal Pan Bracket	V390016	47 Cross Bar Position Tube (Short) 1	V390047
17 Metal Pan Frame	V390017	48 Cross Bar Position Bracket	V390048
18 Left Front Joint	V390018	49 Motor Air In-Tank Cover	V390049
19 Cross Tube	V390019	50 Brush Cap (1)	V390050
20 Arm Frame Right side	V390020	51 Carbon Brushes (2 pcs./set)	V390051
21 Right Front Joint	V390021	52 Main Cross Bar	V390052
22 Ruler Guide	V390022	53 Shaft Spacer Inner	V390053
23 Complete Cutting Table	V390023	54 Main Cross Bar Position Stopper	V390060
23.1 Cutting Table Retention Bracket	V390023.1	63 Screw M5 x 25L	V25155
24 U-Shape Roller Wheels (2)	V390024	64 Screw M4 x 16L	V25105
25 Metal Bearing Rollers (2pcs./set)	V390025	65 Screw M5 x 15L	V3925058
26 Locking Table Bracket	V390026	66 Rubber Feet (4)	V141029
27 Toggle Switch/ (20A)	V390027	68 Circuit Breaker	V141046
28 Toggle Switch Safe Bracket	V390028	69 Power Cable	V141001
29 Inner Flange	V390029	72 Circuit Breaker Bracket	V141068VX
30 Plate Blade Shaft Retaining (qty required=4)	V390030	73 Cable Cover	V141126
31 Shaft Spacer Outer/ (6305 LLB)	V390031	74 M4 x 8 Countersunk Screw	V141127
32 Bearing Blade Shaft Outer/ (6305 LLB)	V390032	76 Reset Button Cover	VS1000-04.1

Name

(Optional) Wet Cutting Kit
Includes: Water Tub, Water Feed, Drip Tray,
Drain Plug, Water Pump

Part Number
V350MSWKIT

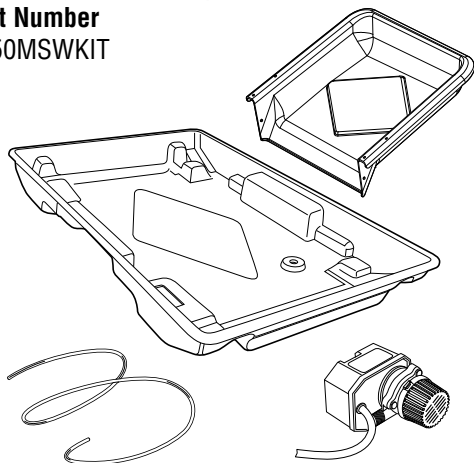

Name (Qty.)

(Optional) Brick Saw Stand (1)

Part Number
V350MS

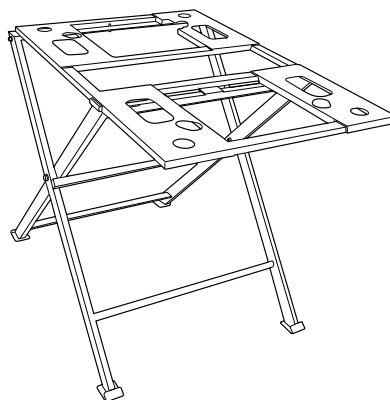

Name (Qty.)

(Optional)
Water Hose Kit (1)

Part Number
V350MSGHKIT

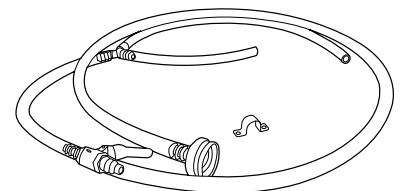

xiii. ELECTRICAL MOTOR SPECIFICATIONS

Horsepower	3 HP
Volts	115V/230V
Amps	15A
Motor RPM	3,600 rpm
Cycle	60 Hz
Watts	2238

⚠ WARNING: To avoid permanent motor damage you must use the correct extension cord. Never use more than one extension cord at a time. Follow the chart for proper size.

WIRE GAUGE	Length of Cord 3 HP - 115 V
No. 10	25'
No. 8	50'
No. 6	75'

Recommendations:

- It is recommended that a **15 amp circuit** be used while operating this saw. This will prevent possible power interruption or loss.
- Always plug saw as close as possible to the power source while operating. This will allow you to receive optimum electricity.

Electrical Wiring Diagram

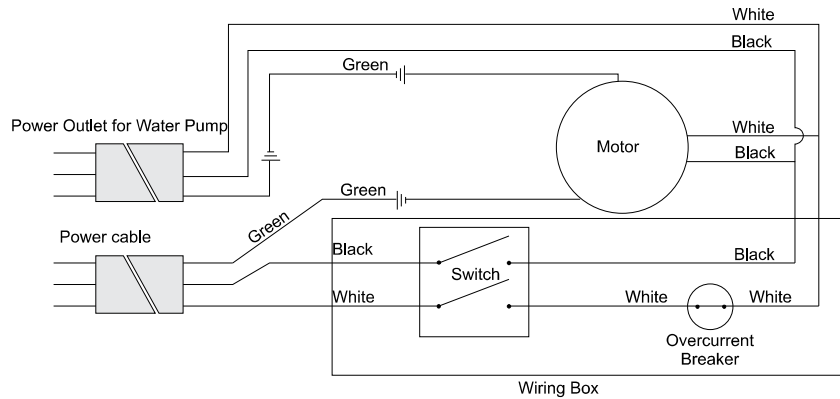

xiv. WATER HOSE KIT INSTALLATION

1. Orient the water pipes as shown in Fig. A. Insert the shortest pipe from the "Y" adapter into the adjacent sleeve at the rear of the blade guard. First, you will need to remove the black cap covering the hole insert (#1). The longest pipe, which has a control valve midway, should be pointed towards the floor. Secure the "Y" adapter to the rear of the blade guard using the provided bracket and screws.
2. Insert the second pipe protruding from the top of the "Y" adapter into the slot located on the side of the blade guard towards the front of the saw. This is the hole in the front of the blade guard (#2), do not remove the black caps on the side. See Fig. B.

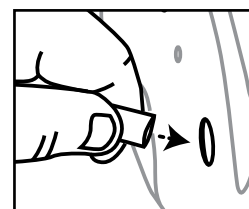
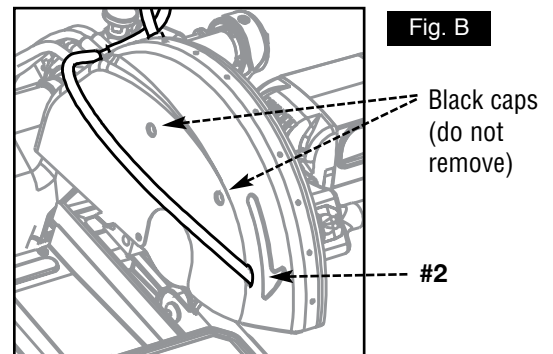
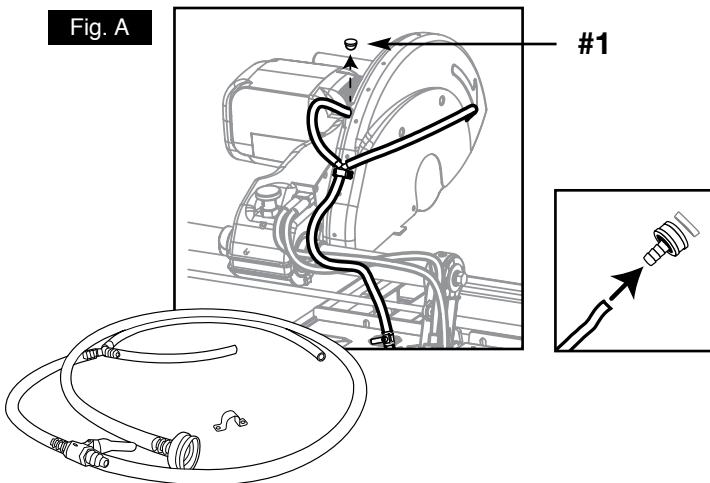

xv. TROUBLESHOOTING



WARNING! *For your safety and the safety of others, turn the power switch off and always remove the plug from power source before troubleshooting. Repairs performed by unauthorized personnel could cause serious hazard. We recommend that service to this tool be performed by a qualified service technician with original equipment replacement parts.*



























Problem	Possible Cause	Solution
Machine does not run when switched on.	Power cord not properly fixed/plugged in.	Check that the machine is properly connected to the power supply.
	Power cord defective.	Have the power cord checked, replaced if necessary.
	Main power switch defective.	Have the main power switch checked and replaced if necessary by a qualified electrician.
	Loose electrical connection inside the electric system.	Have the whole electric system of the machine checked by a qualified electrician.
Motor stops (power cut out).	Motor defective.	Have the motor checked and replaced if necessary by a qualified technician.
	Too much pressure exerted while cutting.	Exert less pressure when cutting.
Motor stops (power cut out).	Incorrect specification for saw blade.	Use a saw blade which corresponds to the material being cut.
	Saw has a defective electric system.	Have the electric system of the saw checked by a qualified technician.
Poor machine performance little power.	Power cord/extension cable too long or cable still wound up inside cable drum.	Use a power cord/extension cable of the rated length, use a cable drum with a cable fully extended.
	Power network is insufficient.	Observe the electric ratings of the machine and connect it only to a power network which complies with these ratings.
	Drive motor no longer runs at rated speed (r.p.m.).	Have the motor checked by a qualified electrician and have it replaced if necessary.

Problem	Possible Cause	Solution
Irregular run of the saw blade.	Poor tension in the blade material.	Return the saw blade to the manufacturer.
Excessive wear.	Wrong type of saw blade. Shaft of motor causes wobbling. Overheating.	Use harder saw blades. Have bearings of the motor of the motor replaced. Ensure optimum flow of cooling water.
Saw blade wobbles when running.	Saw blade is damaged or bent.	Have the saw blade aligned/flattened. Clean the receiving flange.
	Flange of the saw blade is damaged. Shaft of the motor is bent.	Solder the diamond segments of the old blade onto another saw blade or use a new blade. Replace the saw blade flange. Replace the electric motor.
Diamond segment becomes loose.	Overheating of the saw blade; cooling water not sufficient.	Have the diamond segment soldered on the blade again; ensure optimum flow of cooling water.
Cracks in or near the diamond segment.	Saw blade too hard. Fixed flange is worn out.	Use a softer blade. Have the fixed flange replaced.
	Motor shaft bearing.	Replace the bearing of the motor shaft.
Saw blade is blunt.	Saw blade type is unsuitable for the material being cut.	Use appropriate type of saw blade.
	Saw blade type is unsuitable for the machine performance. Saw blade too hard.	
	Diamond segments are blunt.	Sharpen the diamond saw blade.
Appearance of cut is not optimal.	Poor tension in the blade material.	Return the saw blade to the manufacturer.
	Too much load placed on the saw blade. Diamond segments are blunt.	Use a suitable saw blade. Sharpen the saw blade.
The center hole in the saw blade has become wider due to wear.	The saw blade has slipped on the motor shaft when running.	The arbor of the saw blade must be fitted with an appropriate adapter ring. Check the receiving flange and have it replaced if necessary.

Problem	Possible Cause	Solution
Saw blades shows blooming colors.	Lateral friction when cutting.	The material feed is too high; proceed more slowly.
Grinding marks on the saw blade.	Material is not being fed parallel to the saw blade.	Ensure that the direction of feed is absolutely parallel to the saw blade.
	Poor tension in the blade material.	Adjust the roller table/have it adjusted.
	Too much load on the saw blade.	Have the saw blade tensioned. The material feed is too high, proceed more slowly.

xvi. THE RIGHT BLADES DOES THE RIGHT JOB

For the most effective cutting and blade life always use the recommended Pearl Abrasive Co. blade.

PEARL BLADE SERIES	APPLICATION				
	BRICK	BLOCK	PAVER	HARD BRICK	REFRACTORY BRICK
Reactor ADM™ Concrete/Masonry					
P5™ (BB) Masonry					
P5™ (NSP) Hard Materials					
P2 PRO-V™ (SDS) Hard Materials					
P5™ (CSP) Concrete/Masonry					
P4™ (CP) Concrete/Masonry					
P2 PRO-V™ Concrete/Masonry					
P1 EXV™ Concrete/Masonry					

xvii. HOW TO ORDER PARTS

Please have the following information ready before calling:

- Serial Number of your Saw
- Model Number of the Saw
- When purchased and where
- Part Description

All parts listed may be ordered from your Local warehouses. If the part is not stocked locally, call our Corporate office and ask for our Customer Service Department. For Technical Support call **1-800-969-5561**. In Canada call **1-800-387-0008**. There is a \$25.00 minimum order.

Return Policy: Return goods for credit or exchange on the basis of the following terms: **(1)** They must be current products; **(2)** Items returned for replacement or refund should be in original cartons and must be accompanied by a packing slip with the following information: Returned Goods Authorization (RGA) number obtainable from Customer Service Department • List of items returned • Reason(s) for return(s) • Copy of original invoice(s); **(3)** Freight charges must be assumed by sender; **(4)** Returning goods are subject to a 15% handling charge to cover our cost of repacking and restocking. All Prices are subject to change without notice.

Disclaimer: Pearl Abrasive Co. reserves the right to make changes or improvements on its products without incurring an additional obligation including any obligation to make corresponding changes or improvements to products previously manufactured or sold. Pearl reserves the right to discontinue products at any time without notice.

All illustrations displayed in this manual are the property of Pearl Abrasive Co. and shall not be duplicated or reproduced without the express written consent of Pearl Abrasive Co.

PEARL LIMITED WARRANTY

Every PEARL ABRASIVE CO. tool is thoroughly inspected and tested before leaving the factory. It is warranted to be free of defects in materials and workmanship for a period of ONE YEAR from the date of original purchase. Pearl will repair or (at our opinion) replace a product, or part thereof, found by PEARL ABRASIVE CO. to be defective, provided the defective product is returned to PEARL ABRASIVE CO., freight pre-paid, with proof of purchase.

RGA NUMBER IS REQUIRED. Prior to the return of any product or part, a Return Goods Authorization number must be obtained from PEARL ABRASIVE CO. by fax (562) 928-3857 or calling (800) 969-5561. The owner's name, address, phone number, as well as the serial number of the product, proof of purchase, and a brief statement detailing the nature of the claimed defect, are required for authorization.

This Warranty does not apply where:

- repairs have been made or attempted by others
- repairs are required because of normal wear and tear
- the tool has been abused, misused or improperly maintained
- alterations have been made to the tool
- the product is used in a manner or with a blade not recommended by the manufacturer

In no event shall Pearl Abrasive Co. be liable for any indirect, incidental or consequential damages from the sale or use of the equipment. This disclaimer applies both during and after the term of warranty.

Pearl Abrasive Co. disclaims liability for any implied warranties, including implied warranties of "merchantability" and "fitness for a specific purpose", after the one year term of this warranty.

This warranty gives you specific legal rights, and you may also have other rights which vary from state to state. Some states do not allow the exclusion or limitation of incidental or consequential damages, so the above limitation or exclusion may not apply to you. Some states do not allow limitation on how long an implied warranty lasts, so the above limitation may not apply to you.

All parts replaced under warranty will be considered as part of the original product and any warranty on these parts will expire coincidentally with the original product warranty.

This warranty supersedes all previous PEARL ABRASIVE product warranties. **EXCLUSION:** Water pump and motor warranty is through the original equipment manufacturer.

PEARL®

CORPORATE OFFICE: SO. CALIFORNIA • USA
4900 ZAMBRANO ST., COMMERCE, CA 90040-0031
562-927-5561 • FAX 562-928-3857
Toll Free: 800-969-5561
www.pearlabrative.com

GEORGIA • USA
3950 STEVE REYNOLDS BLVD.
NORCROSS, GEORGIA 30093

ONTARIO • CANADA
375-2 PIDO ROAD
PETERBOROUGH, ONTARIO K9J-6X7