

Electric Towing Tractor ***6,500lbs capacity***

FEATURES

- 6,500 lbs lift capacity
Hydraulic pump
- Regenerative braking function
- CURTIS electronic controller
- Emergency reversing device in the handle provides improved operating safety
- Emergency power disconnect switch
- Braking applied with handle upright and horizontal position, increasing the safety of the truck



DRAWINGS

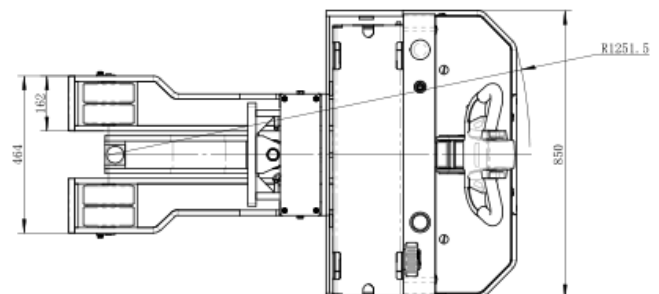
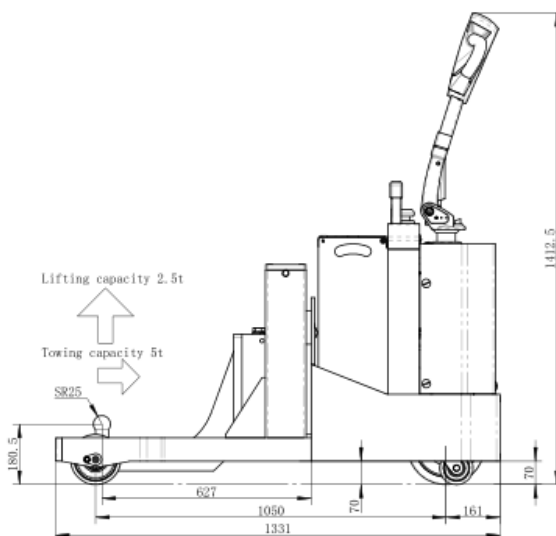

Electric Towing Tractor **6,500lbs capacity**

SPECIFICATIONS

Identification	Product model		SLXTB30
	Power supply		Electric
	Operating type		Pedestrian
	Lifting capacity	Kg	2500kg
	Towing capacity	Kg	3000kg
	Draw-bar-pull At the	Kg	97.6kg
	Weight (without battery)	Kg	435
Wheel	Tires		Polyurethane
	Tire size drive end	mm	230x75
	Tire size load end	mm	150x60
	Balancing wheel size	mm	100x50
	Wheels number (x=drive wheel) drive end/load		1x-2/4
	Tread width drive end	mm	400
	Tread width load end	mm	568
Dimensions	Total height	h1 mm	1400
	Lift height	h3 mm	170
	Height of handle in drive position (Max/Min)	h6 mm	1350/800
	Overall length	L1 mm	1227
	Overall width	b1 mm	850
	Minimum ground	m mm	70
	Turning radius	Wa mm	1200
Performance	Travel speed	km/h	5.2/6
	Lift speed	mm/s	40/50
	Lowering speed	mm/s	50/40
	Max gradeability	%	8/15
	Service brake		Electromagnetic
Electric Motor	Drive motor rating	kW	AC1.5
	Lift motor rating	kW	2.2
	Battery voltage /	V/Ah	24/210
	Battery weight	Kg	195
Others	Type of drive control		MOSFET Control
	Noise level at operator's	dB(A)	70

