

# 20 Ton Towing Tractor With Lift

## FEATURES

- Heavy duty 40,000 lbs capacity
- Regenerative braking function
- CURTIS electronic controller
- Emergency reversing device in the handle provides improved operating safety
- Emergency power disconnect switch
- Braking applied with handle upright and horizontal position, increasing the safety of the truck



## DRAWINGS

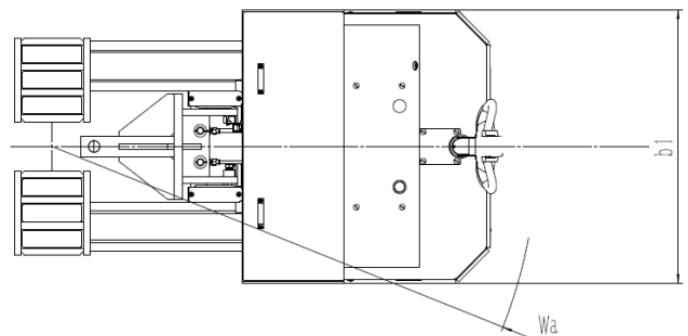
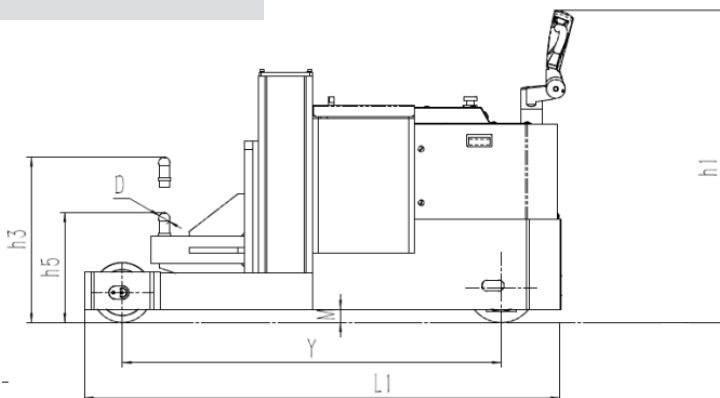

## 20 Ton Towing Tractor With Lift

### SPECIFICATIONS

Identification	1	Product Model		SLXTB200
	2	Power supply		Electric
	3	Operating type		Pedestrian/Standing
	4	Traction Weight	Q (t)	20
	5	Rated traction	F (N)	5000
	6	Wheelbase	Y(mm)	1704
Weight	1	Weight(without battery)	kg	2372
Wheel	1	Tires		Polyurethane
	2	Driving wheel size	mm	Φ343×135
	3	Loading wheel size	mm	Φ267×76
	4	Wheels number (x=drive wheel) Front/Rear		2x-2/6
	5	Tread, drive end	mm	600
	6	Tread, load end	mm	593
Dimension	1	Overall height (Walkie/stand-on driving)	h1 mm	1464/1394
	2	Lifting height	h3mm	690
	3	Towing Head height, lowered	h5mm	490
	4	Diameter of Towing Head	Dmm	50
	5	Height of tiller in drive Position(max/min)	h6mm	1394/1192
	6	Overall Length(standing type)	L1mm	2707
	7	Overall Width	b1mm	1220
	8	Minimum ground clearance(Without loaded)	M mm	60
	9	Turning Radius	Wa mm	2185
Performance	1	Travel speed loaded/unloaded	km/h	5.2/6
	2	Lift speed loaded/unloaded	mm/s	28/30
	3	Lowering speed loaded/unloaded	mm/s	45/40
	4	Max grade ability loaded/unloaded	%	5/15
	5	Service brake		Electromagnetic brake
Motor	1	Driving motor rating	kW	4.5kW×2
	2	Lift motor rating	kW	4kW
	3	Battery voltage/nominal capacity	V/Ah	48/500
	4	Battery weight	kg	780
Others	1	Type of drive control		MOSFET Control
	2	Noise level at operator's ear	dB(A)	<70