

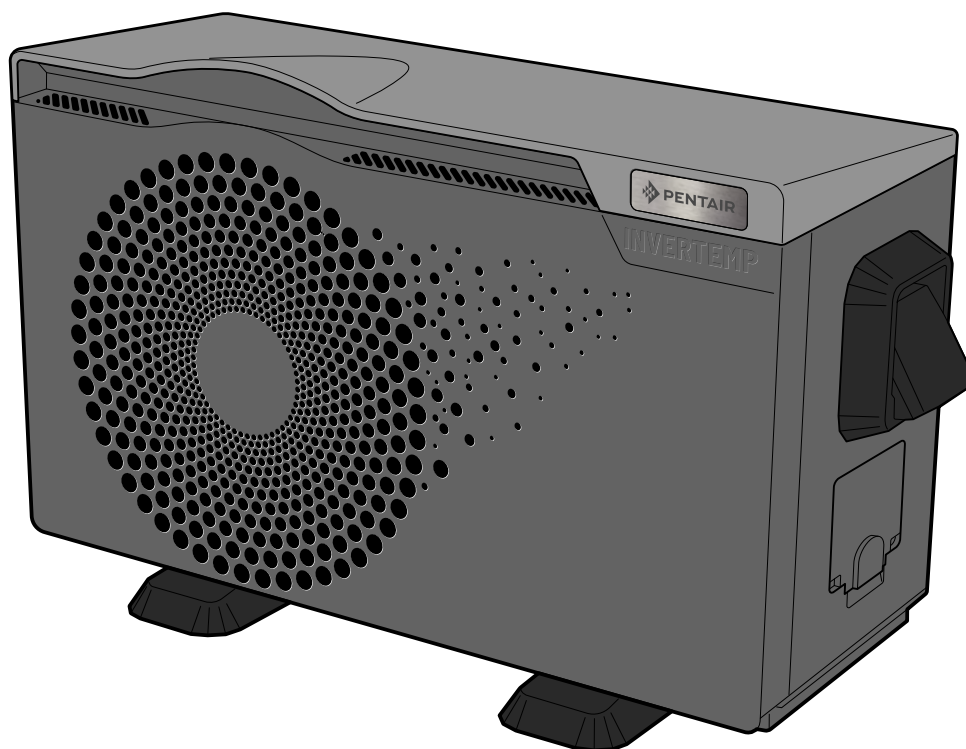

PENTAIR INVERTEMP® FL



IVTP-1M-FL
IVTP-2M-FL
IVTP-3M-FL
IVTP-4M-FL
IVTP-5M-FL
IVTP-6M-FL
IVTP-7M-FL
IVTP-8T-FL

INSTALLATION AND OPERATING MANUAL

IMPORTANT SAFETY INSTRUCTIONS,
PLEASE READ AND FOLLOW ALL THE INSTRUCTIONS,
KEEP THESE INSTRUCTIONS

PENTAIR AQUATIC SYSTEMS
(Rev. 12/2021)

EN



Download the manual available in EN / FR / NL / DE / IT / ES / PO on www.pentairpooleurope.com



Pentair thanks you for your trust and for purchasing the Pentair InverTemp®-FL, the full inverter swimming pool heat pump. In this manual, the heat pump is referred to as HP. To fully enjoy all the features of your InverTemp® HP, please read this operating manual attentively. Keep it in a secure place so that you can refer to it at any moment.



Declaration of conformity

Guidelines - Harmonised standards

Pentair International Sarl - Avenue de Sévelin 20 - 1004 Lausanne - Switzerland

We hereby declare under our sole responsibility that this product complies with the relevant guidelines

SAFETY	EN 60335-1:2012/A2:2019	EN 60335-2-40:2003/A13:2012	EN 62233:2008	
EMC	EN 55014-1:2017	EN 55014-2:2015	EN 61000-3-2:2014	EN 61000-3-3:2013
	EN 61000-3-11:2000	EN 61000-3-12:2011		
NOISE	200/14/CE			

INVERTEMP :

IVTP-1-M-FL / IVTP-2-M-FL / IVTP-3-M-FL / IVTP-4-M-FL / IVTP-5-M-FL / IVTP-6-M-FL / IVTP-7-M-FL / IVTP-8-T-FL

Other normative documents

RoHS 2011/65/EU

WEEE 2012/19/EU

Person authorised to manage technical documentation

Pentair International S.a.r.l
Avenue de Sévelin 20
1004 Lausanne - Switzerland

Lausanne, 2021 11 25

Jacques Van Bouwel
Engineering Mgr



Operating temperature: -15° to 38°C

Power supply: 230 V ~, 50 Hz

IP:X4

Maximum operating altitude: 2000 m

- Product: IVTP-1M-LT	Max power consumption: 1.6 kW	Weight: 37 kg	- Product: IVTP-5M-LT	Max power consumption: 3.1 kW	Weight: 53 kg
- Product: IVTP-2M-LT	Max power consumption: 1.7 kW	Weight: 37 kg	- Product: IVTP-6M-LT	Max power consumption: 3.7 kW	Weight: 61 kg
- Product: IVTP-3M-LT	Max power consumption: 2.0 kW	Weight: 43 kg	- Product: IVTP-7M-LT	Max power consumption: 4.5 kW	Weight: 88 kg
- Product: IVTP-4M-LT	Max power consumption: 2.7 kW	Weight: 43 kg	- Product: IVTP-8T-LT	Max power consumption: 5.4 kW	Weight: 88 kg

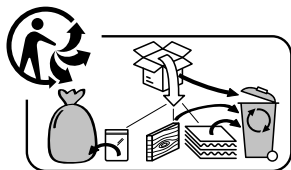

Processing by individuals of electronic appliances reaching the end of their lifespan:

The crossed-out bin placed on the main parts which make up the product indicates that it must not be disposed of together with the household waste. It must be returned to an appropriate collection point for electronic device recycling (information available from the local household waste collection service). This product contains potentially dangerous substances which may have adverse effects on the environment and human health.

- Hotline After sales service / SAV: +33(0)1 84 28 09 40

- Internet site: www.pentairpooleurope.com

- Guarantee excluding consumables: 3 years

© 2022 Pentair International SARL, All rights reserved

- This document is subject to changes without prior notice

Trade names and waivers: Pentair InverTemp® and Pentair® are trade names and/or registered trade names of Pentair and/or companies affiliated to Pentair. Unless otherwise stated, the names and brands of third parties used in the present document are not used to indicate any affiliation or endorsement between the owners of these trade names and Pentair. These names and brands can be registered trade names of said third parties or others.

TABLE OF CONTENTS

> IMPORTANT WARNINGS AND SAFETY INSTRUCTIONS	p 01
> TABLE OF CHARACTERISTICS	p 02
> DELIVERY - TRANSPORT, GENERAL DESCRIPTION	p 03
> INSTALLATION (SITE, TYPE OF SUPPORT, NECESSARY SPACE)	p 04
> DIMENSIONS, HYDRAULIC CONNECTION	p 05
> ELECTRICAL CONNECTION	p 06
> IMMERSION, START UP, USE	p 07
> ADJUSTMENT	p 08
> REGULATION (ELECTRONIC CONTROL UNIT)	p 11
> WIFI CONNECTION	p 12
> TABLE OF THE DIFFERENT STATES OF THE DISPLAY	p 13
> MAINTENANCE - WINTERING	p 14
> CIRCUIT DIAGRAM	p 15
> RECYCLING	p 17

WARNING AND IMPORTANT SAFETY INSTRUCTIONS



This symbol indicates that the device uses R32, a coolant featuring a low combustion speed.



This symbol indicates that a maintenance technician must handle this equipment according to the operating manual.



This symbol indicates that the operating manual should be read attentively prior to use.



WARNING: In normal conditions, a suitable HP can heat the water of the pool by 1°C to 2°C per day. It is therefore quite normal not to feel a temperature difference at the outlet of the circuit when the HP is operating. A heated pool should be covered to prevent heat losses.

The appliance is designed to be used in a swimming pool as described in standard NF-EN-16713.

- Failure to comply with the warnings could cause damage to the swimming pool equipment as well as severe injuries or death.
- Only a qualified person possessing the adequate technical skills (electricity, hydraulic, refrigeration) is authorised to undertake maintenance operations or repairs on the device. A qualified technician working on the device must use/wear personal protective equipment (safety goggles, protection gloves, etc...) to avoid all risk of injury arising during work on the device.
- Prior to any intervention on the device, ensure that it is powered down and has undergone the lockout-tagout procedure.
- The device is designed specifically for use in swimming pools and spas; it must not be used for purposes other than the ones it was designed for.
- This device is not intended for children.
- This device is not intended to be used by persons (including children, of 8 or more) who lack experience or who suffer from physical, sensory, or mental impairment, except:
 - if it is operated under supervision or with operating instructions issued by a person responsible for their safety; and
 - if they understand the risks taken.
- Children must be supervised to ensure that they do not play with the device.
- The installation of the device should be carried out according to the manufacturer's instructions and in compliance with local and national applicable standards. The installer is responsible for the installation of the device and for compliance with national regulations relating to installation procedures. The manufacturer will not be liable in case of non-compliance with the installation standards that apply locally.
- For any action other than simple maintenance operations by the user as described in this manual, the product should be maintained by a certified professional.
- Any improper installation and/or use can cause damages and severe injuries (and even death).
- Do not touch the fan or the moving parts, and do not insert objects or your fingers close to the moving parts when the device is operating. Moving parts can cause severe injuries and even death.
- Do not pull on the hoses and the connections to move the machine.

WARNINGS CONCERNING ELECTRICAL APPLIANCES:

- The power supply of the device must be protected by a 30-mA security residual current protection system, as per the standards that apply in the country of installation.
- Do not use an extension to connect the device; only connect the device directly to a suitable power outlet.
- If a fixed device does not feature a power cord and a plug, or any other means to disconnect from the power supply with a separation of the contacts in all the poles, enabling total disconnection in case of a category III electrical surge, the manual will mention that the disconnection means must be integrated in the fixed wiring, as per relevant wiring rules.
- An adapted disconnection method, complying with all local and national requirements relating to category III electrical surges, and that disconnects all the poles of the supply circuit, must be installed in the supply circuit of the device. This disconnection method is not provided with the device and should be provided by the installation technician.
- Prior to installation, check that:
 - The voltage featuring on the information plate of the device matches the voltage of the power supply,
 - The power supply is suitable for operating the device and has an earthing connection.
 - The plug (as necessary) adapts to the plughole.
- If the power cord is damaged, it should imperatively be replaced by the manufacturer, a technician or a person qualified to ensure safety.

WARNINGS RELATING TO DEVICES CONTAINING A COOLANT:

- The coolant R32 is a coolant of category A2L, which is considered as potentially flammable.
- Do not release R32 or R410A fluid into the atmosphere. This fluid is a greenhouse effect fluorinated gas, covered by the Kyoto Protocol, with a global warming potential (GWP) = 675 for R32 and 2088 for R410A (European regulation EU 517/2014).
- The device must be stored in a well-ventilated place and kept away from flames.
- Install the unit outdoors. Do not install the unit indoors or in an outdoor area that is closed and poorly ventilated.
- To comply with the relevant standards and regulations in terms of the environment and installation procedures, and in particular with decree N° 2015-1790 and/or European regulation EU 517/2014, a search for leaks of the cooling circuit must be conducted at least once a year. This operation should be carried out by a certified specialist of cooling devices.
- Please keep and transmit these documents for reference throughout the lifespan of the device.

TABLE OF CHARACTERISTICS

Model	IVTP-1M-FL	IVTP-2M-FL	IVTP-3M-FL	IVTP-4M-FL	IVTP-5M-FL	IVTP-6M-FL	IVTP-7M-FL	IVTP-8T-FL
Conditions	Dry air temperature: 28°C - Relative humidity: 80% - Input water temperature: 28°C							
Heating capacity (boost Mode)	7,3 kW	9,3 kW	10,6 kW	13,1 kW	16,1 kW	20,4 kW	24,2 kW	27,8 kW
Continuous power (COP) (boost Mode)	6,5 ~ 5,9	6,5 ~ 5,5	6,8 ~ 5,4	6,8 ~ 5,6	5,1 ~ 6	5,9 ~ 5,2	6 ~ 5,4	5,9 ~ 5,2
Heating capacity (Smart mode)	7,3 ~ 3,2 kW	9,3 ~ 3,5 kW	10,6 ~ 3,9 kW	13,1 ~ kW	16,1 ~ 5,5 kW	20,4 ~ 6,5 kW	24,2 ~ 7,8 kW	27,8 ~ 10,5 kW
Continuous power (COP) (Smart mode)	10,8 ~ 5,9	10,8 ~ 5,5	10,8 ~ 5,4	11,2 ~ 5,6	10,8 ~ 5,1	10,1 ~ 5,2	10,8 ~ 5,4	10,1 ~ 5,2
Heating capacity (Eco mode)	5,8 ~ 3,2 kW	5,8 ~ 3,5 kW	7,1 ~ 3,9 kW	8,4 ~ 4,2 kW	9,9 ~ 5,5 kW	12,2 ~ 6,5 kW	16,3 ~ 7,8 kW	18,6 ~ 10,5 kW
Continuous power (COP) (Eco mode)	10,8 ~ 8,3	10,8 ~ 8,3	10,8 ~ 8,3	11,2 ~ 8,5	10,8 ~ 8,3	10,1 ~ 8,1	10,8 ~ 8,3	10,1 ~ 8,1

Conditions	Dry air temperature: 15°C - Relative humidity: 70% - Input water temperature: 28°C							
Heating capacity (boost Mode)	5,6 kW	6,6 kW	7,8 kW	9,8 kW	11,5 kW	14,8 kW	18,2 kW	22,8 kW
Continuous power (COP) (boost Mode)	5,3	5,3	5,2	4,7	5,1	4,5	4,6 ~ 4,4	4,5 ~ 4,2
Heating capacity (Smart mode)	5,6 ~ 2,6 kW	6,6 ~ 3,2 kW	7,8 ~ 3,5 kW	9,8 ~ 3,7 kW	11,5 ~ 4,2 kW	14,8 ~ 4,9 kW	18,2 ~ 6,8 kW	22,8 ~ 8,1 kW
Continuous power (COP) (Smart mode)	6,7 ~ 5,3	6,7 ~ 5,6	6,7 ~ 4,9	7,0 ~ 4,5	6,7 ~ 4,2	6,6 ~ 4,3	6,7 ~ 4,4	6,5 ~ 4,2
Heating capacity (Eco mode)	2,9 ~ 2,6 kW	3,8 ~ 3,2 kW	4,9 ~ 3,5 kW	7,8 ~ 3,7 kW	6,7 ~ 4,2 kW	8,5 ~ 4,9 kW	10,2 ~ 6,8 kW	12,5 ~ 8,1 kW
Continuous power (COP) (Eco mode)	6,7 ~ 5,6	6,7 ~ 5,6	7,1 ~ 6,1	7,0 ~ 5,5	6,7 ~ 5,7	6,6 ~ 5,6	6,7 ~ 5,7	6,5 ~ 5,6

Conditions	Dry air temperature: 7°C - Relative humidity: 0% - Input water temperature: 26°C							
Heating capacity	2,75 kW	3,35 kW	4,65 kW	5,45 kW	5,8 kW	8,3 kW	9,72 kW	12,11 kW
Continuous power (COP)	2,86	2,82	3,96	3,64	2,83	3	2,98	2,81

Sound pressure at 10m (Eco mode)	24,9 dB(a)	24,5 dB(a)	27,4 dB(a)	26,9 dB(a)	28,1 dB(a)	28,9 dB(a)	31,9 dB(a)	31,4 dB(a)
Compressor	Mitsubishi / Toshiba 2D Full DC Inverter							
Expansion valve	Electronic							
Cabinet	Painted sheet metal - Reinforced ABS, UV protection and equipped with soundproof panels							
Refrigerant	Recyclable refrigerant with no impact on the ozone layer (R32)							
Hydraulic connection	1,5" / 50 mm							
Supply voltage	230V / 1 ~ +N / 50 Hz							400V / 3 ~ +N/50 Hz
Fuse rating	C 10 A	C 10 A	C 10 A	C 16 A	C 20 A	C 20 A	C 25 A	C 16 A
Power supply cross section	3G 2,5 mm ²	3G 2,5 mm ²	3G 2,5 mm ²	3G 2,5 mm ²	3G 4 mm ²	3G 4 mm ²	3G 6 mm ²	5G 2,5mm ²
Minimum water flow	4 m ³ /h			5 m ³ /h			6 m ³ /h	
Weight	40 kg	40 kg	46 kg	46 kg	57,5 kg	65,5 kg	86 kg	86 kg

DELIVERY TRANSPORT

When you have unpacked the HP, please check the content to report any damage. Please also check that the pressure reading on the pressure gauge is equal to the pressure mentioned on the box, depending on the measured outdoor temperature, as different values might indicate a leak.

The HP should always be stored and transported in a vertical position, on a pallet and inside its original packaging.

Transporting and/or storing the HP horizontally will void the guarantee.

GENERAL DESCRIPTION

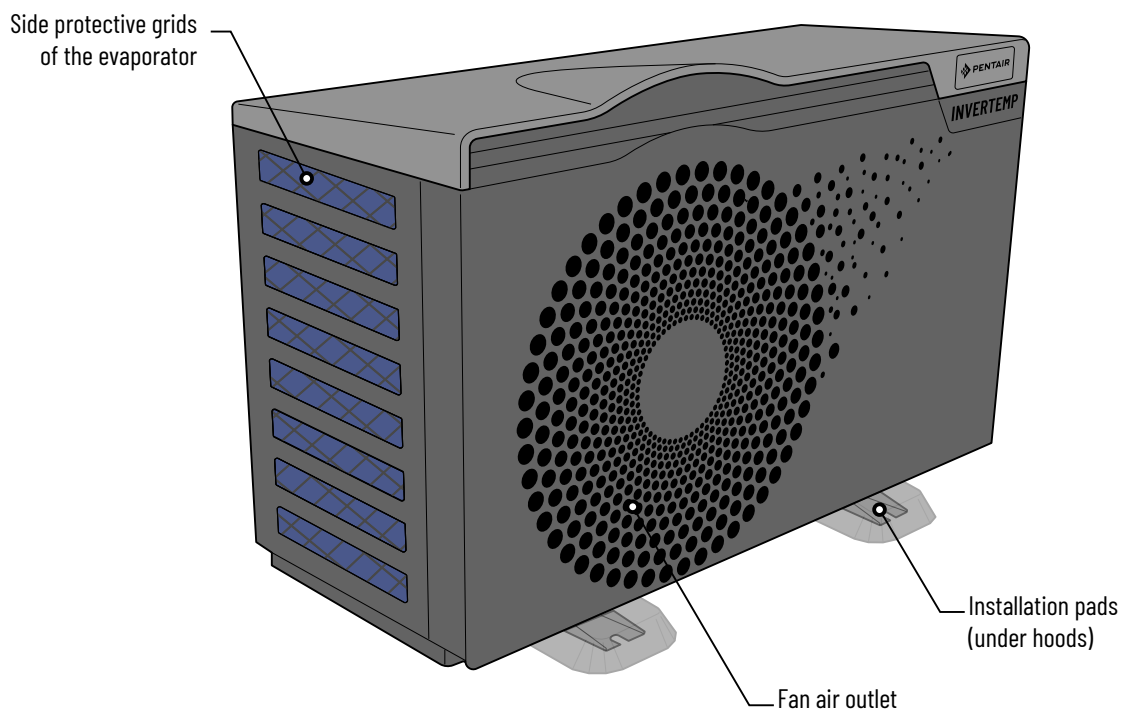
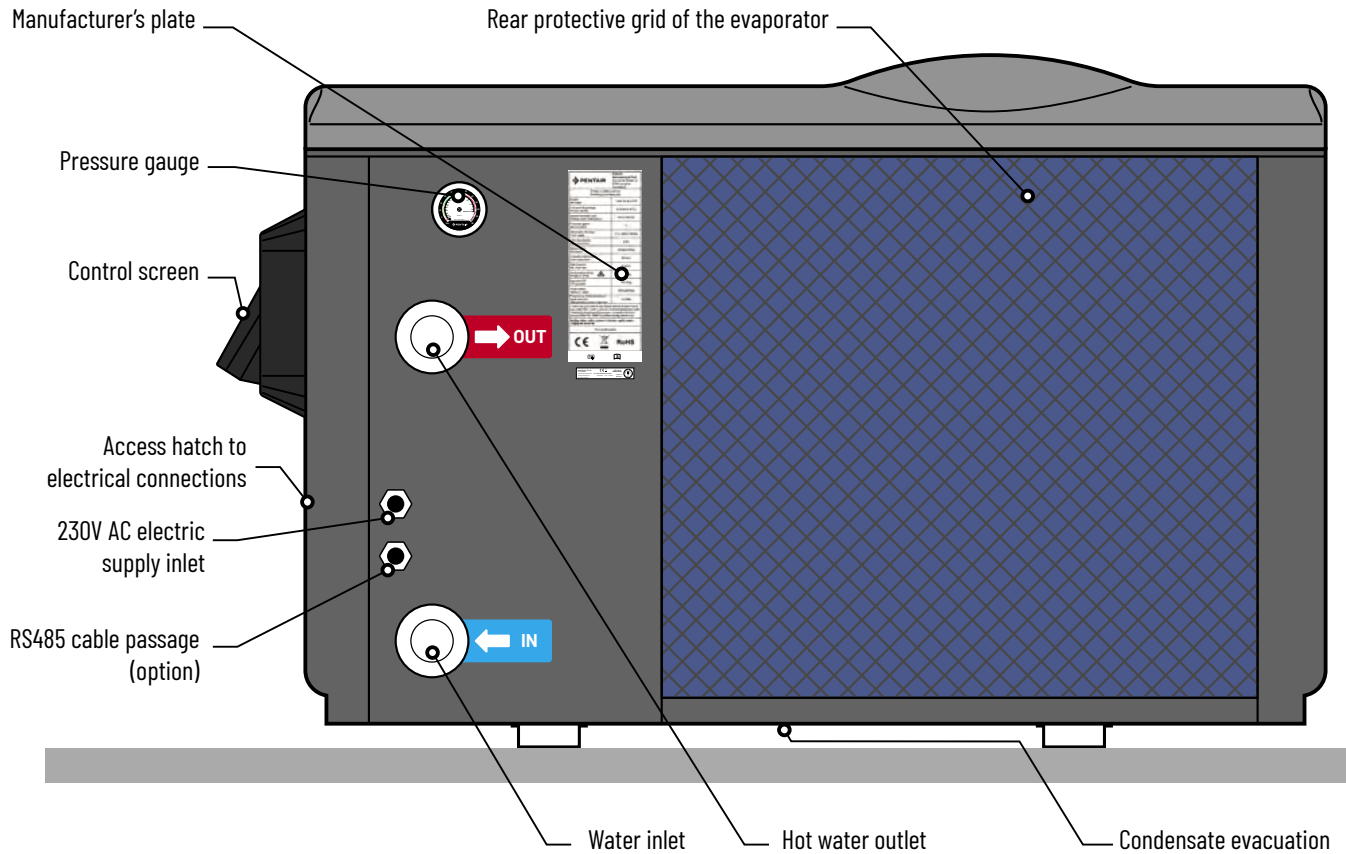

INSTALLATION (SITE, TYPE OF SUPPORT, NECESSARY SPACE)

- Install the HP outdoors at more than 2 metres from the pool, as per applicable laws (NF C 15 100).
- Place the HP on the provided vibration absorbers on a surface that is stable, solid (able to bear the weight of the device) and level (prepare a concrete base if necessary).
- Maintain 1 m (30 cm minimum) of open space in front of the vertical air intake grids (behind and on the side of the HP) and 3 m at the outlet of the fan (in front of open space without any obstacles).
- Prepare sufficient space around the HP for maintenance operations.
- Prepare a water evacuation system close to the HP to protect the installation zone.
- Keep the HP out of the reach of children, insofar as possible.

The HP should never be installed:

- in an area covered by sprinkling systems, or subject to spray or running water or mud (close to a road, take into account the effects of wind),
- under a tree,
- close to a source of heat or of flammable gas,
- in an area where it would be exposed to oil, flammable gases, corrosive products, and compounds containing sulphur,
- close to equipment operating at high frequencies,
- in a place where snow is likely to accumulate,
- in a place where it could be flooded by the condensates produced by the device as it operates,
- on a surface that could transfer the vibrations to the house.

Advice: dampen the possible noise nuisance caused by your HP.

- Do not install it close to or underneath a window.
- Do not direct the outlet of the fan towards your neighbours' property.
- Do not direct the fan outlet (cold air) towards the swimming pool.
- Install it in an open area (sound waves bounce off surfaces).
- Install a sound barrier around the HP, making sure to maintain the required distances.
- Install 50 cm of PVC piping at the water inlet and outlet of the HP.

To improve its performance, it is recommended to insulate the piping between the HP and the swimming pool, especially if the distance is significant.

Space to maintain around the HP:

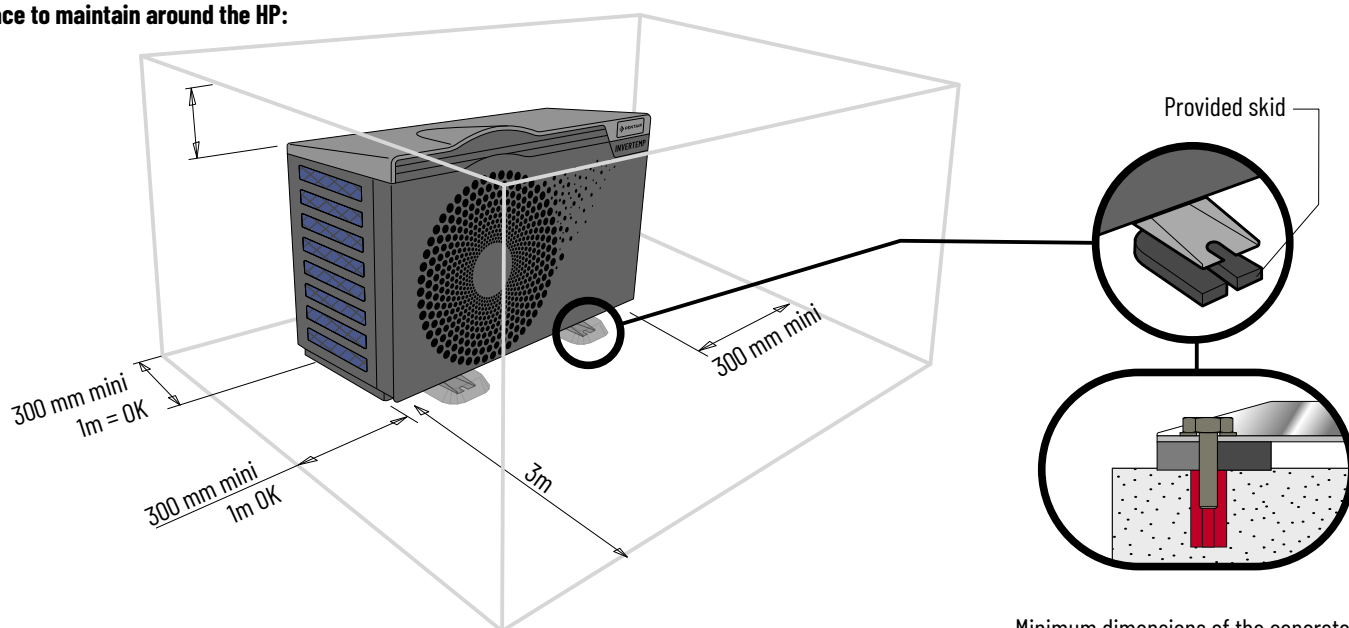

The HP must be installed and maintained on a fixed and solid basis, with the skids placed under the feet.

- For concrete, use adapted $\varnothing 8$ mm lag screws fitted with washers to prevent any loosening.
- For wood, use adapted $\varnothing 8$ mm hexagon head screws fitted with locking washers to prevent any loosening.
- Cover the front of the feet with the provided hoods, push down to the clipping system.

Minimum dimensions of the concrete slab

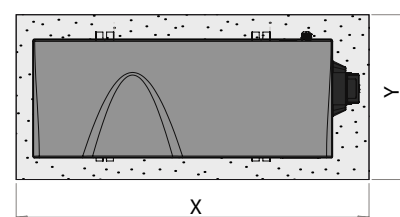

IVTP-1M-FL / IVTP-2M-FL / IVTP-3M-FL / IVTP-4M-FL :
X : 1200 mm Y : 650 mm

IVTP-5M-FL / IVTP-6M-FL:
X : 1300 mm Y : 700 mm

IVTP-7M-FL / IVTP-8T-FL:
X : 1400 mm Y : 750 mm

DIMENSIONS:

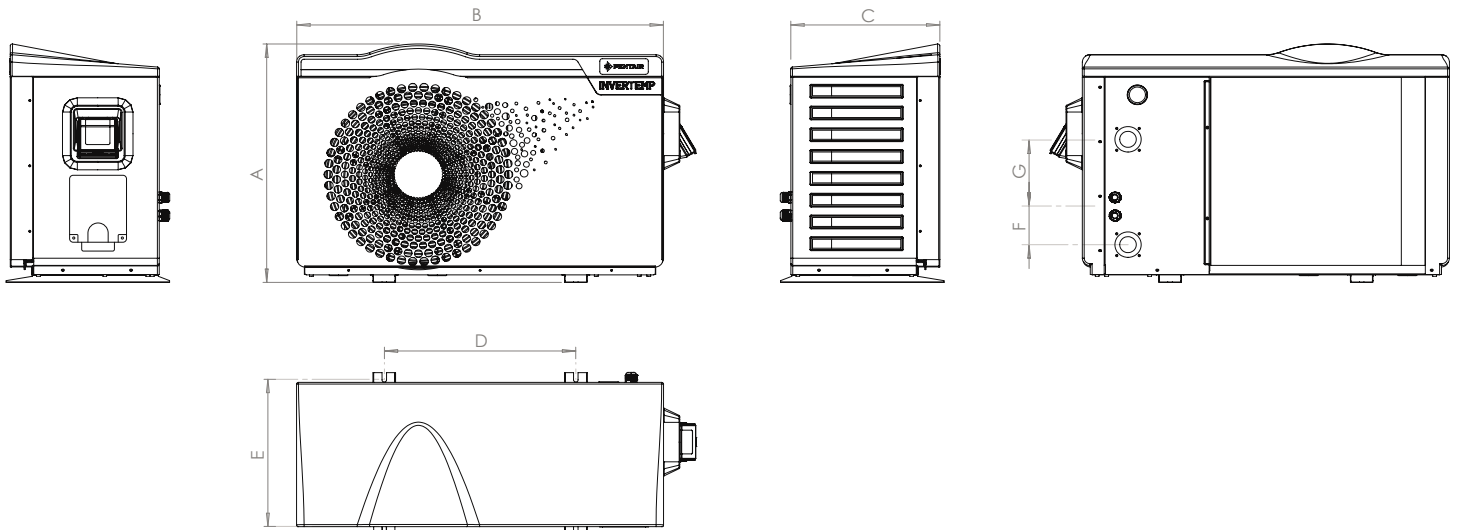

Models	A	B	C	D	E	F	G
IVTP-1M-FL IVTP-3M-FL IVTP-2M-FL IVTP-4M-FL	657 mm	977 mm	397 mm	510 mm	410 mm	103 mm	290 mm
IVTP-5M-FL IVTP-6M-FL	756 mm	1076 mm	450 mm	669 mm	465 mm	92 mm	320 mm
IVTP-7M-FL IVTP-8T-FL	922 mm	1175 mm	508 mm	669 mm	485 mm	92 mm	430 mm

HYDRAULIC CONNECTIONS:

- Water quality necessary for this device: NF-EN-16713-3
- The HP is compatible with all types of water treatment. The HP must imperatively be connected by a PVC pipe of \varnothing 50mm to the swimming pool's hydraulic circuit, after the filter and before the treatment system, regardless of its type (Cl, pH, Br metering pumps and/or electrolyser).
- Follow the hydraulic connection order (blue = water in, red = water out)
- A bypass must be installed to facilitate work on the HP.
- Before connecting the PVC pipes to the HP, make sure the circuit is clean of any work residue (stone, soil, etc.).

Connection of the condensate evacuation pack:

During operations, the HP is subject to a condensation phenomenon. This translates into a water flow, which can be more or less important depending on the degree of humidity. To channel this flow, which can represent several litres of water per day, we recommend you install the provided condensate evacuation pack and connect it to a suitable water evacuation circuit.

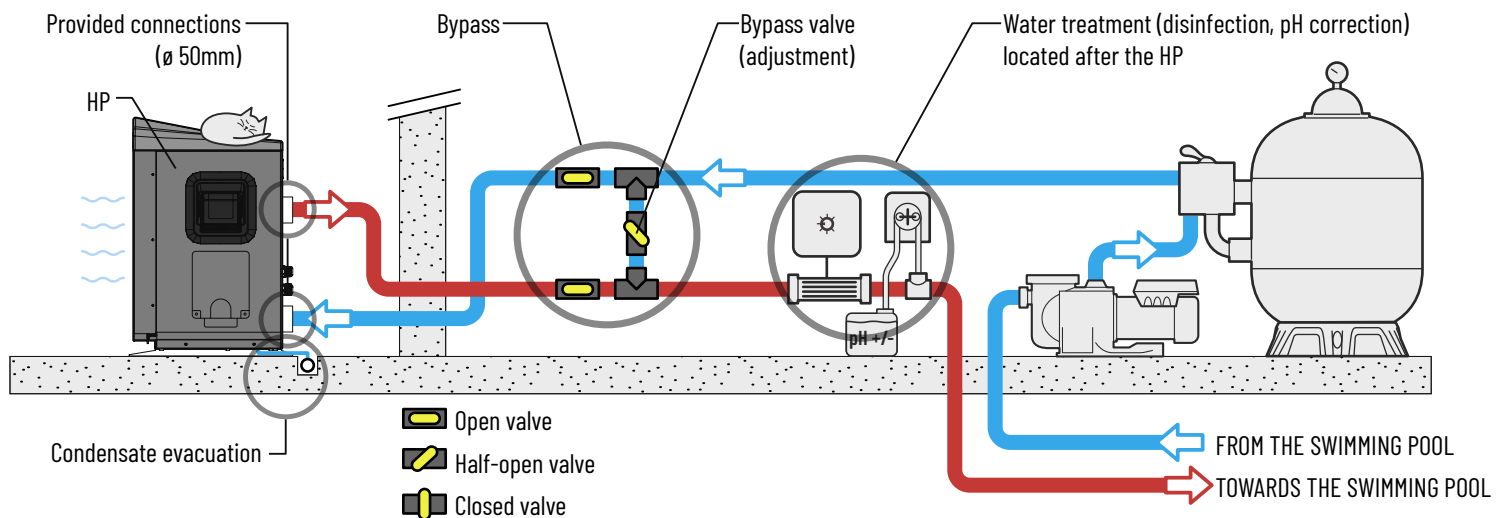

ELECTRICAL CONNECTIONS:

Connection of the power supply:

- Prior to undertaking any intervention inside the HP, it is imperative to disconnect the power supply from the HP: there is a risk of electrocution that can cause damages, severe injuries, and even death.
- Only a certified and experienced technician is authorised to conduct cabling work in an HP or to replace the power cable.
- The power supply should match the voltage featuring on the information plate of the HP.
- The HP must be connected to an earthing connection.

Electric installation:

To ensure safe operations and to protect the integrity of your electric installation, the HP should be connected to the electrical mains according to the following rules:

Upstream, the electrical mains should be protected by a 30-mA differential switch.

The HP should be connected to a suitable class C circuit-breaker (see the table below) according to the standards and regulations in force in the country where the system is installed.

The power cord should be adapted to the power of the HP and the length of cable required for the installation (see the table below). The cable must be suitable for outdoor use.

In the case of a three-phase system, it is imperative to follow the connection order of the phases.

If phases are inverted, the compressor of the HP will not work.

In public spaces, the installation of an emergency stop button close to the HP is mandatory.

The voltage must match the voltage mentioned on the HP.

The connections must be sized based on the power of the HP and on the installation state.

Models	Power supply	Max current	Diameter of the R02V cable and maximum cable length		Magnetic-thermal protection (C)
IVTP-1M-FL	Single-Phase 230 V ~, 50 Hz	4.9 A	3x2.5 mm ² / 34m	3x4 mm ² / 54m	10 A
IVTP-2M-FL		6.3 A	3x6 mm ² / 80m	3x10 mm ² / 135m	
IVTP-3M-FL		8.9 A	3x2.5 mm ² / 25m	3x4 mm ² / 35m	16 A
IVTP-4M-FL		11.5 A	3x6 mm ² / 45m	3x10 mm ² / 80m	
IVTP-5M-FL		13.5 A	3x4 mm ² / 30m	3x6 mm ² / 40m	20 A
IVTP-6M-FL		16.0 A	3x10 mm ² / 70m		
IVTP-7M-FL		19.5 A	3x6 mm ² / 20m		25 A
IVTP-8T-FL	Three-phase 380 V ~, 50 Hz	23.5 A	5x2.5 mm ² / 20m		16 A

- Use the cable-gland and the pass-through provided inside the HP for the passage of the cables.
- As the HP is installed outdoors, the cable must pass through a protection sheath provided for that purpose. The power supply of the HP must be provided with a protection system according to applicable law.
- The electric cables must be buried at a depth of 50 cm (85 cm under a road or a path) in an electric sheath (ringed and red). When a buried sheathed cable intersects with another cable or a duct (water, gas...), the distance between the two must be greater than 20 cm.

ELECTRICAL CONNECTIONS:

Heating priority:

The filtration pump can be connected to the HP to force the filtration to operate if the water is not at the desired temperature.

Prior to this connection, a "dry contact" (normally open relay or connector) with a 230V AC coil should be provided.

Electrical connections:

- Connect the coil of this relay (A1 and A2) on the P1 and P2 terminals of the HP.
- Connect the input and the output of the dry contact (normally open) in parallel with the dry contact of the filtration clock of the swimming pool.

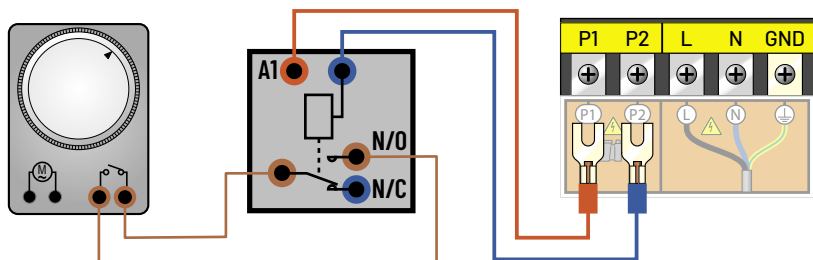

Parameter for taking the connection into account:
Check that the setting of the filtration pump parameter (parameter #9) is set to "1". If this is not the case, please contact us to change the setting.

IMMERSION AND STARTING THE HP AT THE BEGINNING OF THE SEASON:

Once the HP is connected to the water circuit with the bypass, and is connected to the power supply by a professional, ensure that:

- The HP is horizontal (level).
- The HP is secured and stable.
- The water circuit has been purged of air that has been trapped in the piping of the HP.
- The pressure gauge, at the back of the HP, shows a temperature that is equal to the ambient outdoor temperature.
- The water circuit is properly connected (no leaks or damage to the hydraulic connections, the connections are properly tightened).
- The electric circuit is properly connected (the cables are tightly secured to the terminals and intermediate circuit-breaker), properly insulated, and connected to the earthing connection.
- The conditions of installation and use described above have all been met.
- The outdoor temperature is between 0 and +35°C.
- The water temperature is of 15°C minimum.
- The evaporator at the rear/on the sides of the HP is clean (leaves, dust, pollen, cobwebs...)

You can now start your device by following, in the given order, the following steps:

- Open the 3 valves of the bypass (refer to the hydraulic diagram).
- Half-close the bypass valve.
- Remove all unused items or tools from the area surrounding the HP.
- Start the pump of the filtration system.
- Power up the HP by engaging the circuit-breaker and using the ON/OFF button of the display.
- Check that the HP starts and stops in sync with the filtration circuit: if no water is detected in the HP, the display shows "FLO"
- The HP starts after a delay of a few minutes.
- Adjust the temperature ("Regulation" chapter).
- Adjust the water flow ("Water flow setting" chapter).
- After a few minutes, you can adjust the bypass valve as indicated in the "Water flow setting" chapter. Having completed the above steps, cover the pool and let the HP operate for a few days with the filtration pump in "forced mode" until the water of the pool reaches the desired bathing temperature.

USE

- Cover the pool with a cover (bubble cover, shutter...) to reduce heat losses.

SETTINGS:

Water flow setting:

- To optimise the heating performance and achieve power savings, the flow of water travelling through the HP should be adjusted.
- The adjustment is done based on the reading of the adjustment pressure gauge. The adjustment is done by opening or closing the adjustment valve of the bypass.
- To increase the pressure on the front pressure gauge: reduce the amount of water passing through the HP: open the bypass adjustment valve.
- To reduce the pressure on the front pressure gauge: increase the amount of water passing through the HP: close the bypass adjustment valve.
- During normal operations, the inlet and outlet valves must remain fully open.

Normal pressure:

- The flow of water through the HP and the fluid pressure in the device are intimately linked.
- The flow value given for information purposes is of 5 to 7m³/h, i.e. approximately 100l/min to reach the maximum heating power of the HP.
- The ideal setting is achieved when the hand of the pressure gauge (for heating operations in boost or Hi mode) indicates a temperature in °C greater by 10 to 15°C than the current temperature of the swimming pool.
- Remember, the HP must operate for a few minutes before the pressure stabilises on the pressure gauge.
- Example: the swimming pool water is 20°C, the HP has been operating for 5 minutes, and the hand of the pressure gauge indicates 20 bars / 280 PSI / 32°C / 90°F. -> 32°C - 20°C = 12°C -> the setting is right (between 10 and 15°C).

Abnormal pressure:

- If the pressure at the pressure gauge is too high or too low, that means that the flow of water through the HP is inadequate.
- Action must therefore be taken by opening or closing progressively the bypass adjustment valve, to get the pressure in the recommended range.
- When stopped, the temperature reading should be close to the temperature of the swimming pool water.
- If the hand shows 0, the device should not be used (contact your distributor).

Setting frequency:

- The flow through the HP depends much on water temperature, and to a lesser extent, on air temperature.

It should therefore be adjusted:

- When the pump is started, and the water is cold
- During the rise of temperature
- When the desired temperature has been reached.

There should not be any reason to subsequently adjust the flow. An occasional reading of the pressure gauge to ensure everything is operating normally and the flow remains unchanged is generally sufficient.

GENERAL USE:

Water quality (standard):

- The recommended water quality must comply with the following standards.
 - Chlorine concentration less than 2.5 ppm
 - pH between 6.9 and 8
 - In case of sudden chlorination, isolate the heat pump by shutting the inlet and outlet valves of the device, and reset them to their initial positions after treatment.

Maintaining the temperature:

- Once the desired temperature has been reached, you can set the daily filtration time according to your habits (8 to 10 hours per day minimum during the season). The heat pump will start automatically whenever necessary. The minimum operating time varies based on the time of use, please contact your distributor for further information.

If you notice the water temperature of the pool is falling, despite the device operating continuously, increase the daily filtration time.

Do not forget to cover the pool with an insulated cover when you are not using it, to limit heat losses.

IMPORTANT: a swimming pool without a cover will lose 4 times more energy than the same pool with a cover.

The choice of the heat pump should always take into account the presence of a tarpaulin, a rolling shutter, or any other type of protection of the pool when it is not being used.

ELECTRICAL CONNECTIONS :

- As the HP is installed outdoors, the cable must pass through a protection sheath provided for that purpose. The power supply of the HP must be provided with a protection system according to the applicable law.
- The electric cables must be buried at a depth of 50 cm (85 cm under a road or path) in an electric sheath (ringed and red). When a buried sheathed cable intersects with another cable or a duct (water, gas...), the distance between the two must be greater than 20 cm.

Electrical connections (power supply, remote control (RS-485) as an option)

Note: your HP can be controlled through a dry contact (switch) or the Pentair RS-485 bus.

- 1: Remove the access hatch by unscrewing the two screws
- 2: Use the existing cable pullers to pull each cable of a suitable cross section (see the diagram below) into the free strain relief bushing (2.1 for the supply, 2.2 for the switch / RS-485).
- 3: Lead the cable up to the respective terminal and tightly secure the cable clamp. Pull on the cable to check that it does not slip.
- 4: Connect the supply (3 strands for single phase, 5 strands for three phase) in accordance with the diagrams below.
- 5: Connect the switch or BUS RS-485 in accordance with the diagram below
- 6: Replace and screw on the hatch again

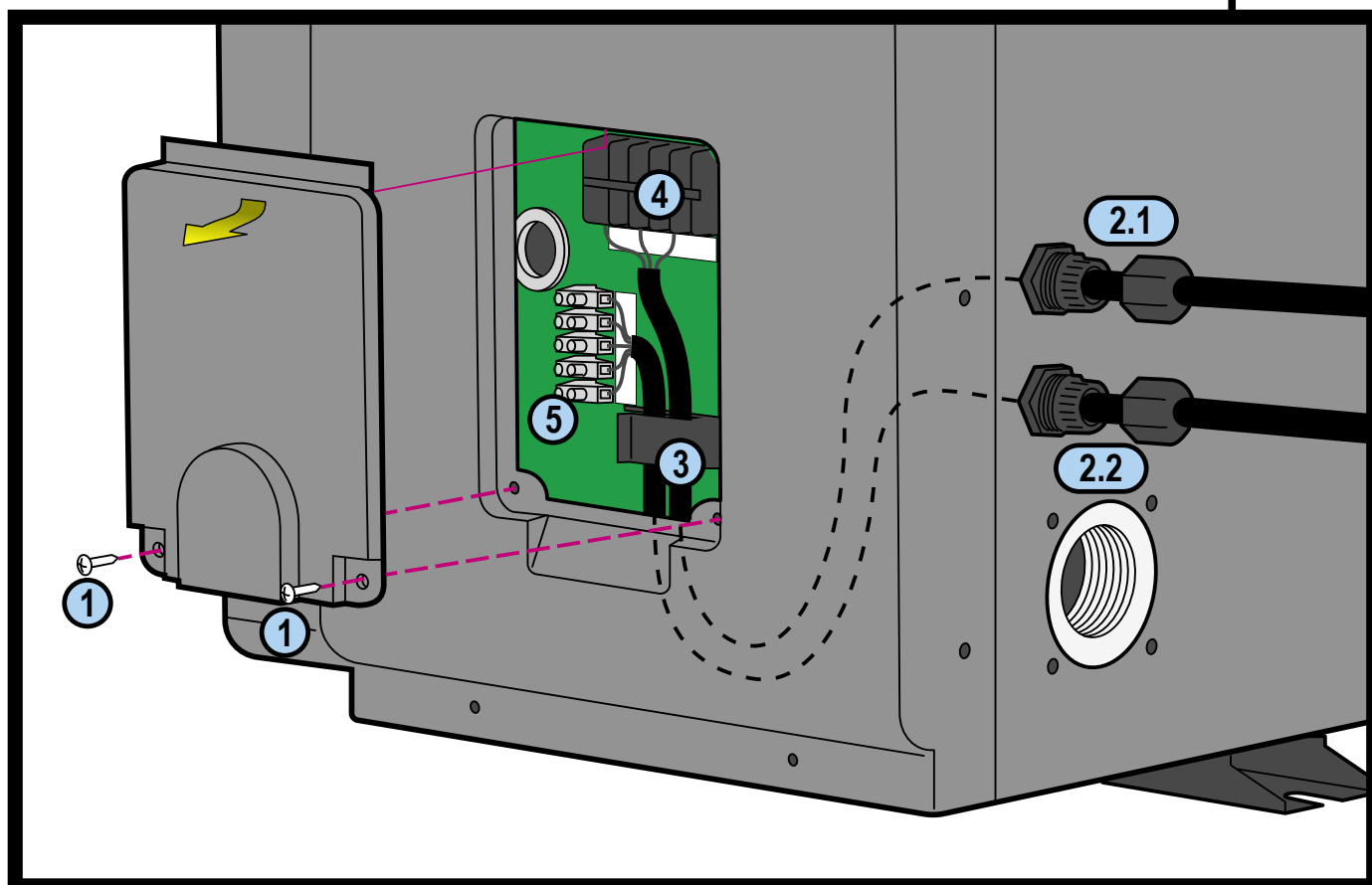
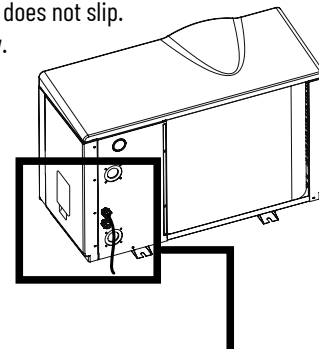

Terminal connections:

Single-phase version:

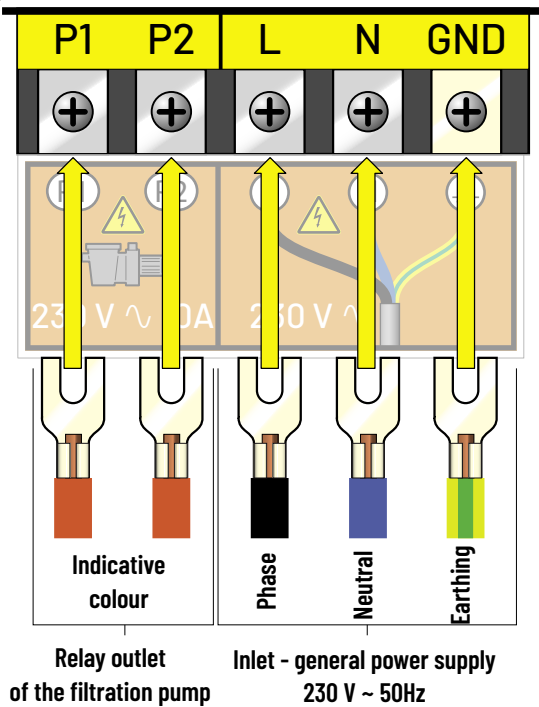

Three-phase version:

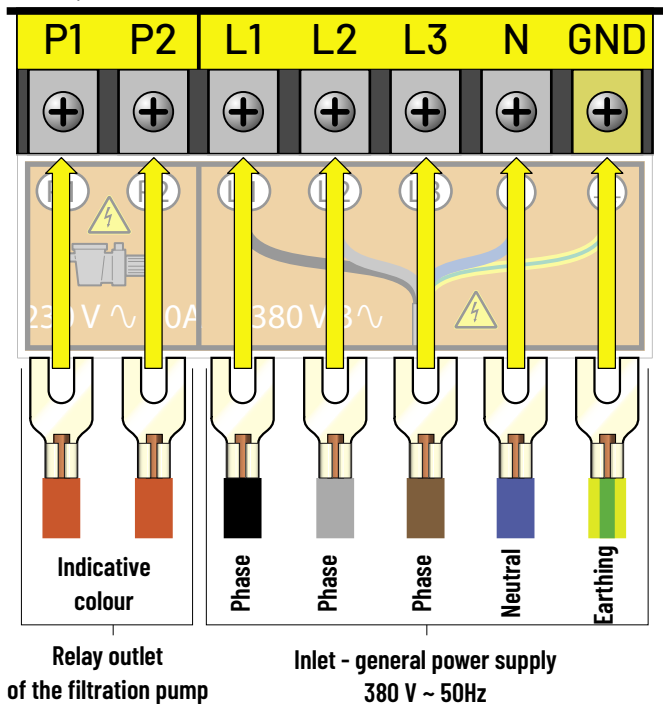

Remote control:

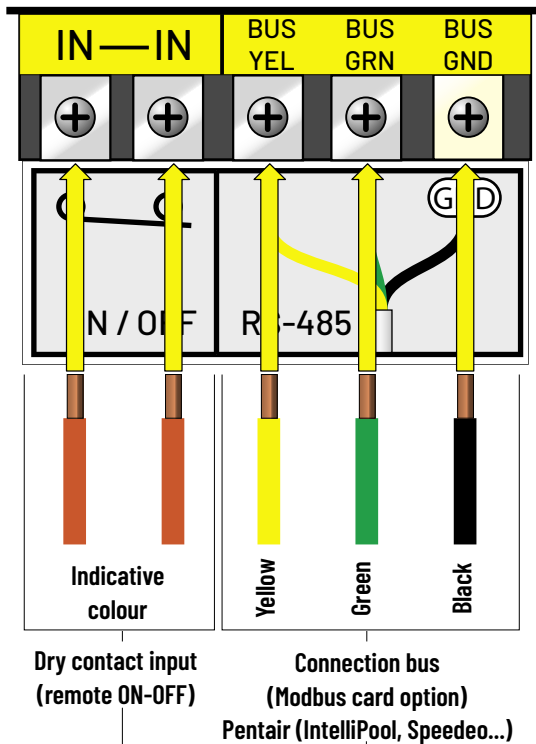

Dry contact input (remote ON-OFF), remove the shunt that is present

Pentair bus connection (IntelliPool, Speedeo ...)

Connection to Maestro:

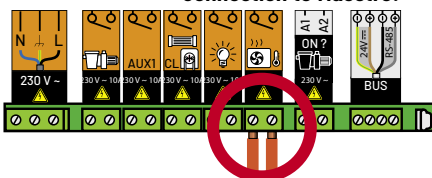

Connection to IntelliPool:

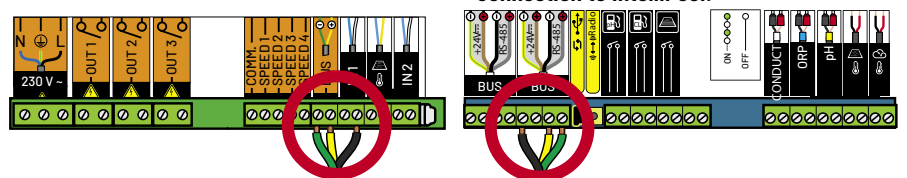

REGULATION (ELECTRONIC CONTROL UNIT)

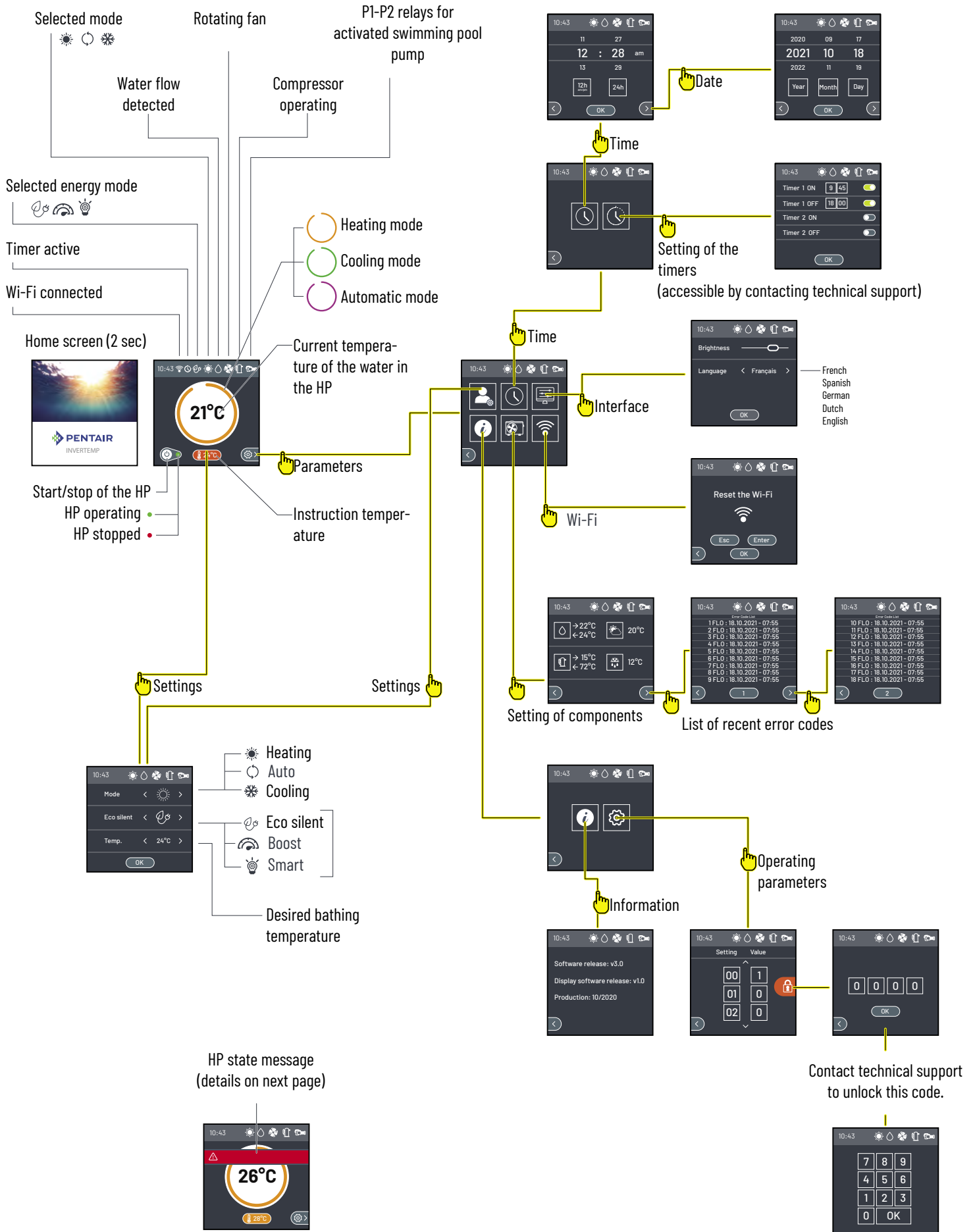

#1: Application download

In the Apple or Android store, download the app Smart Life - Smart Living



#2: Create an account and log in

Follow the account creation instructions

#3: Add the heat pump

#3.1: Click "Add"

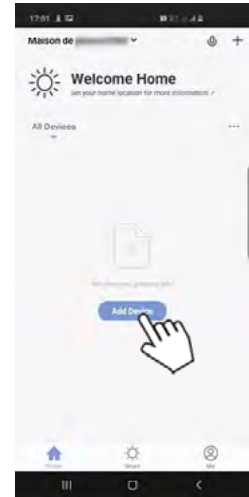

#3.2: Select "Large device"

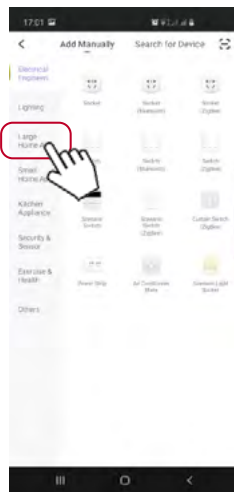

#3.3: Select "Smart Heat Pump (BLE + WiFi)"

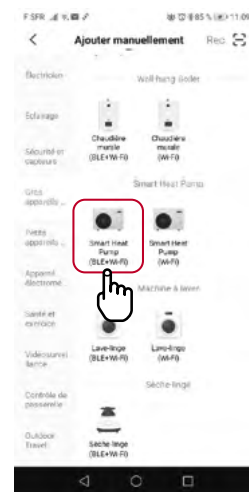

#4: Input the Wi-Fi

#4.1: Press "Enter"



#4.2: Press "Next"

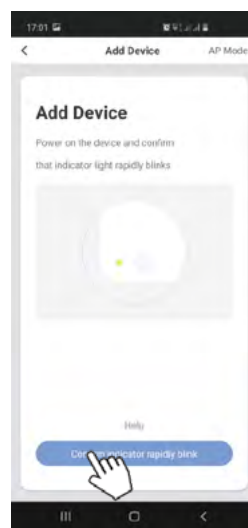

#4.3: Select the desired network, enter the password then confirm



#5: Use the app

#5.1: Pairing



#5.2: Your HP is connected

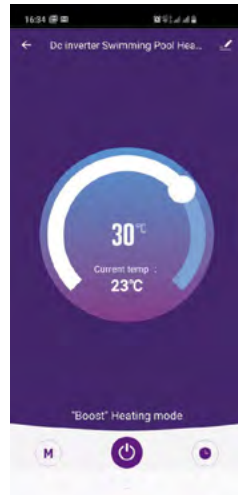

OPERATING MODES

- ECO-SILENCE heating or cooling mode: the most economical and silent.

The HP varies the component speed to maintain an optimum sounds level and yield.

Use of 30% to 60% of the power. The COP and sound level are prioritised, the fan works at min. speed and the compressor runs to optimise the COP.

- SMART heating or cooling mode: the most intelligent mode adapts to your requirements and to the environment.

The HP varies the speed of the components to maintain an optimum power/sound level ratio.

Use of 30% to 100% of the power. The power and sound level automatically adjust depending on the external temperature and the temperature of your pool water.

- BOOST heating or cooling mode: maximum HP power.

BOOST heating or cooling mode: maximum HP power.

The HP can vary the component speed to maintain maximum power.

Use of 85% to 100% of the power to quickly increase the temperature.

TABLE OF THE DIFFERENT STATES OF THE DISPLAY

Display	Meaning	Verification	Action required
St-by	Standby		
FLO	No/insufficient water flow	<ul style="list-style-type: none"> - Check the water flow in the device. - Check the clogging of the filter. - Check the bypass setting. - Check the direction of the passage of water in the device (inlet bottom, outlet top). 	Contact your distributor.
AL10 / AL11	HP error		
AL15 / AL16	Excessive temperature difference between water outlet/inlet		
AL18	Excessive temperature at the compressor outlet		
AL17	Temperature protection too low in cooling mode		
AL7 / AL8	Communication error.	Check the connections between the display and the electronic card in the device.	
AL3	Sensor error (water inlet)	Check that the sensor in question is correctly connected.	
AL4	Sensor error (water outlet)		
AL5	Sensor error (evaporator)		
AL1	Sensor error (compressor outlet)		
AL2	Sensor error (compressor inlet)		
AL8	Sensor error (ambient)		
AL9	Fan error	Check the fan connections.	
AL14	Temperature too low	The outdoor temperature is $< 0^{\circ}\text{C}$.	Wait for the temperature to rise.
AL19 / AL20	Power supply issue	Have the installation checked by a qualified technician.	Contact your distributor.
AL21 / AL22 AL23 / AL24 AL25	Electronic/overheating problem.	Power down the device for 5 to 10 minutes, check that it is properly ventilated, and that the air flow is not blocked or slowed down. Power the device back up.	
EA08	Phase inversion	Check the phase order	
EA09	Phase loss		Reconnect the phases and ensure that the markings are respected

MAINTENANCE

- Prior to undertaking any maintenance operation on the HP, it is imperative to disconnect the power supply from the HP: there is a risk of electrocution that can cause damages, severe injuries, and even death. Maintenance operations are to be conducted by a qualified technician.

Cleaning (must be conducted by a qualified technician at least once yearly):

- The cleaning of the inlet of the evaporators and of the outlet of the fan are necessary to maintain a sufficient yield.
- The HP outer casing must be cleaned with a damp soft cloth (microfibre for example). The use of detergent and other household products might damage the surface of the casing and change its properties.
- The evaporator, at the rear of the HP, can be cleaned carefully using a soft brush vacuum cleaner, just a soft brush, or a stream of soft water; never use a high-pressure hose.

Yearly maintenance, safety checks (must be conducted by a qualified technician at least once yearly):

Prior to any maintenance operation, it is imperative to power down the device and to wait a few minutes before installing pressure control devices, as the high pressure and temperature in some parts of the cooling circuit could cause severe burns.

- Check that the electric cables are properly connected.
- Check that the earth terminals are properly connected to the earth.
- Check the state of the pressure gauge, and that the pressure is aligned with the temperature (table below), and for the presence of coolant.

+55°C = 34.2 bar	+30°C = 18.3 bar	+18°C = 12.9 bar	+6°C = 8.8 bar	-6°C = 5.7 bar	-18°C = 3.3 bar
+50°C = 30.4 bar	+28°C = 17.3 bar	+16°C = 12.2 bar	+4°C = 8.2 bar	-8°C = 5.2 bar	-20°C = 3.0 bar
+45°C = 26.9 bar	+26°C = 16.3 bar	+14°C = 11.4 bar	+2°C = 7.6 bar	-10°C = 4.8 bar	
+40°C = 23.8 bar	+24°C = 15.4 bar	+12°C = 10.7 bar	0°C = 7.1 bar	-12°C = 4.4 bar	
+35°C = 20.9 bar	+22°C = 14.5 bar	+10°C = 10.0 bar	-2°C = 6.6 bar	-14°C = 4.0 bar	

WINTERING

1 - Turn off the power supply to the HP

2 - Fully open the bypass valve and close the HP inlet and outlet valves.

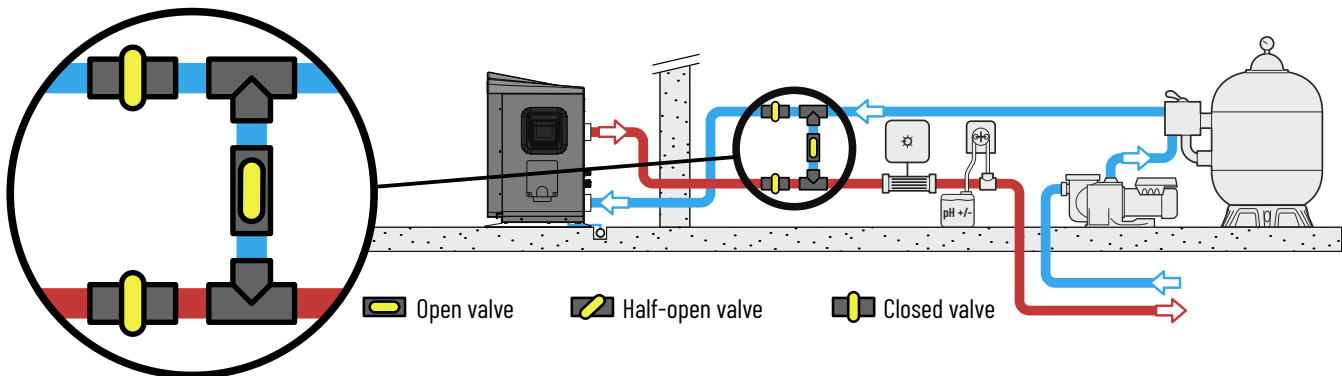

3 - Unscrew the junctions to evacuate all the water contained in the HP.

4 - Reconnect and slightly tighten the junctions by hand to prevent the introduction of foreign objects into the HP

5 - Place the provided wintering blanket over the HP

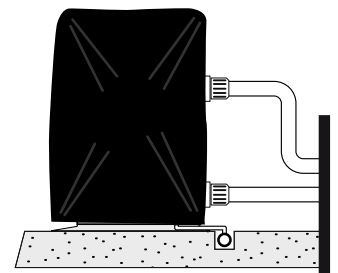
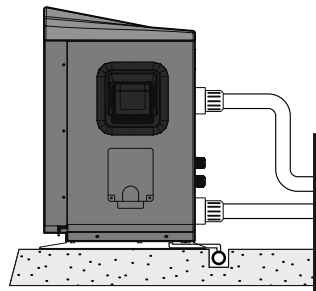
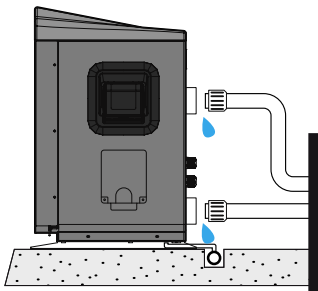

IVTP-1M-FL IVTP-2M-FL IVTP-3M-FL IVTP-4M-FL

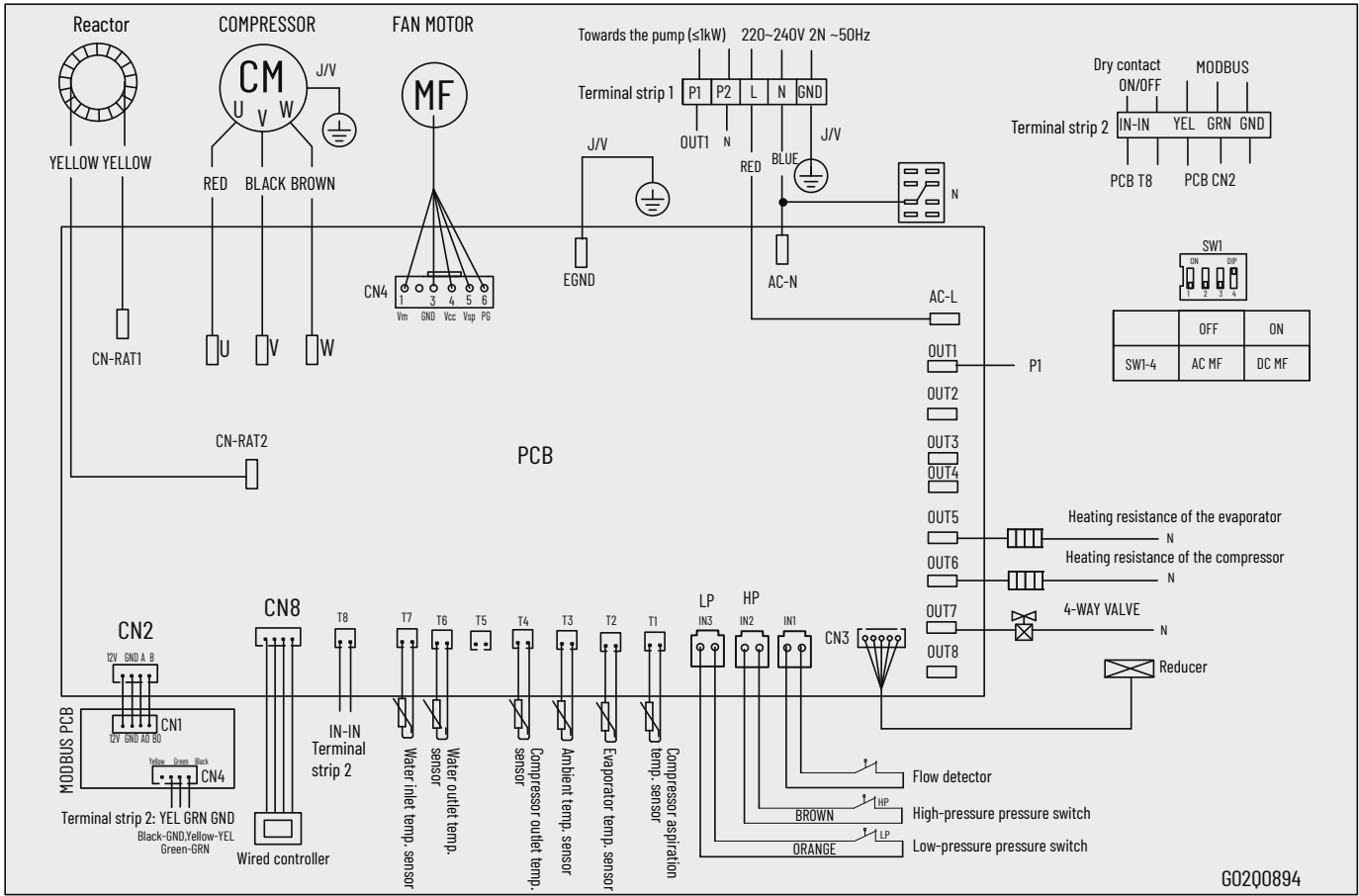

IVTP-5M-FL IVTP-6M-FL

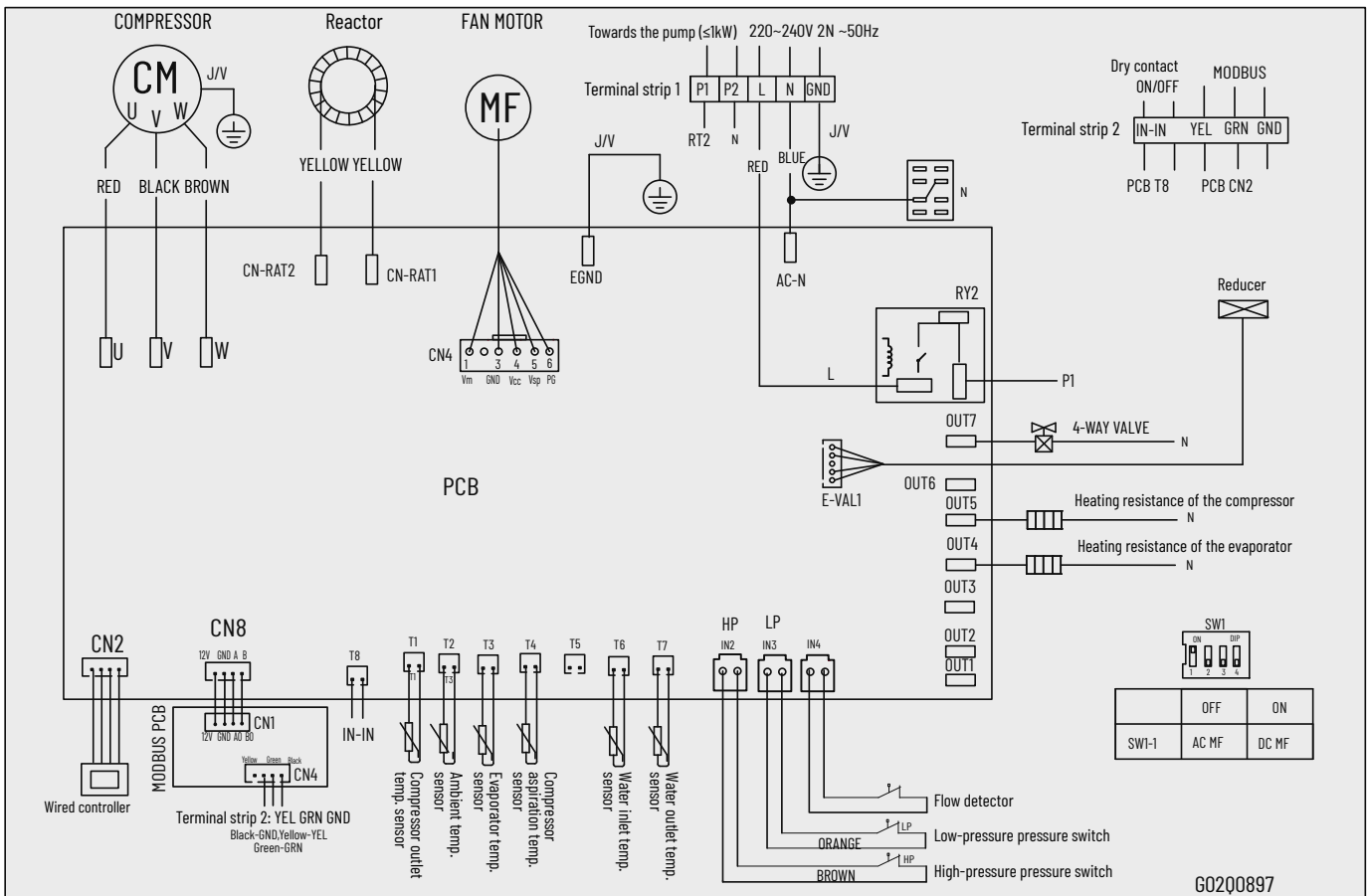

IVTP-7M-FL

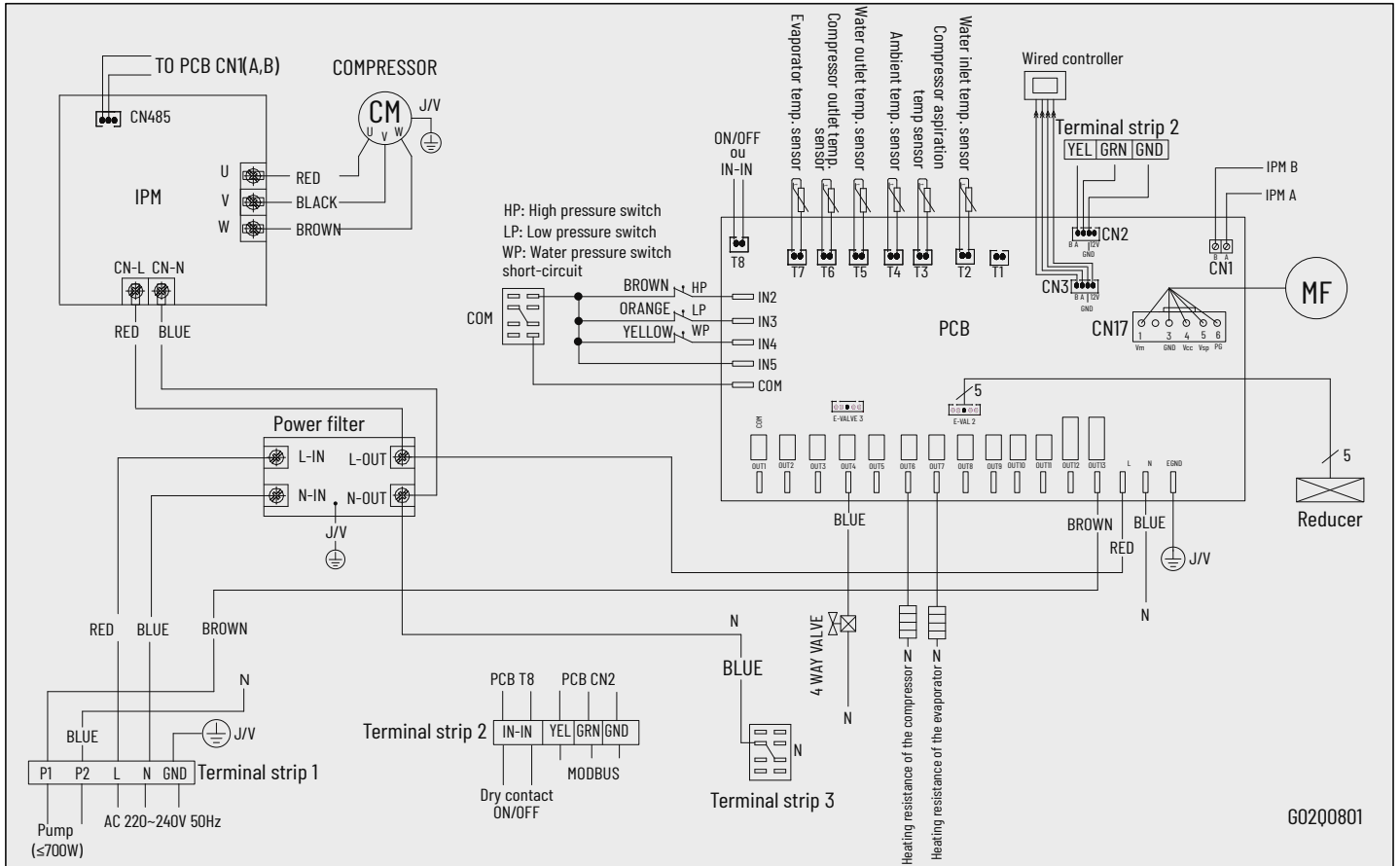

IVTP-8T-FL

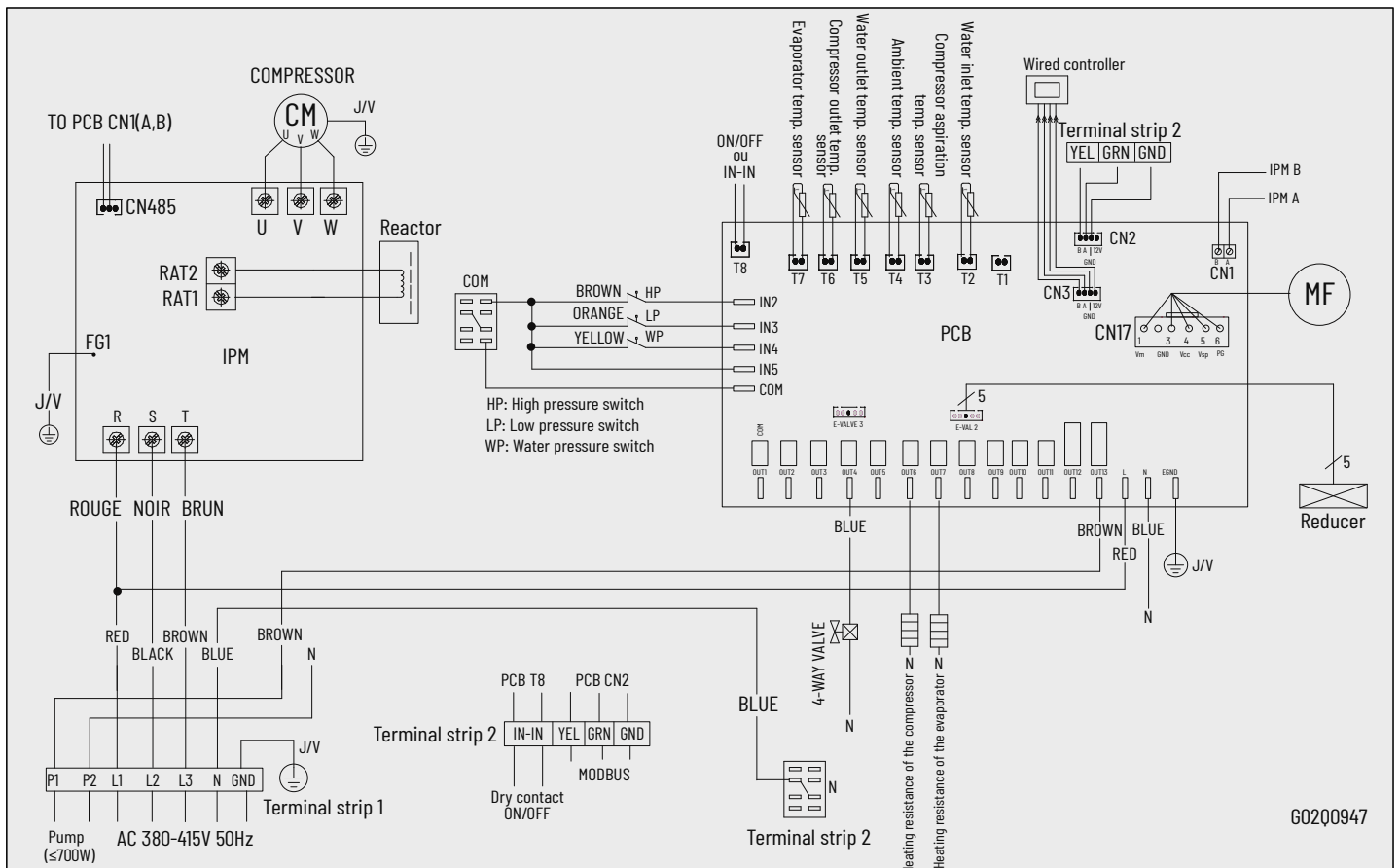

RECYCLING THE HP

When your HP reaches the end of its lifespan and you do not wish to keep it, do not throw it out with household waste.

The HP must be brought to a selective recycling point for its reuse or recycling.

It contains potentially hazardous substances that may harm the environment and that must, during recycling, be eliminated or neutralised.

One of the following solutions should therefore be selected:

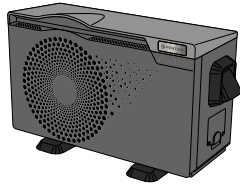

Bring the HP to a recycling centre

Give the HP to a not-for-profit organisation so that it can be repaired and reused

Give the HP to the shop when buying a new unit

DETAILED INFORMATION CONCERNING INTERNAL COMPONENTS

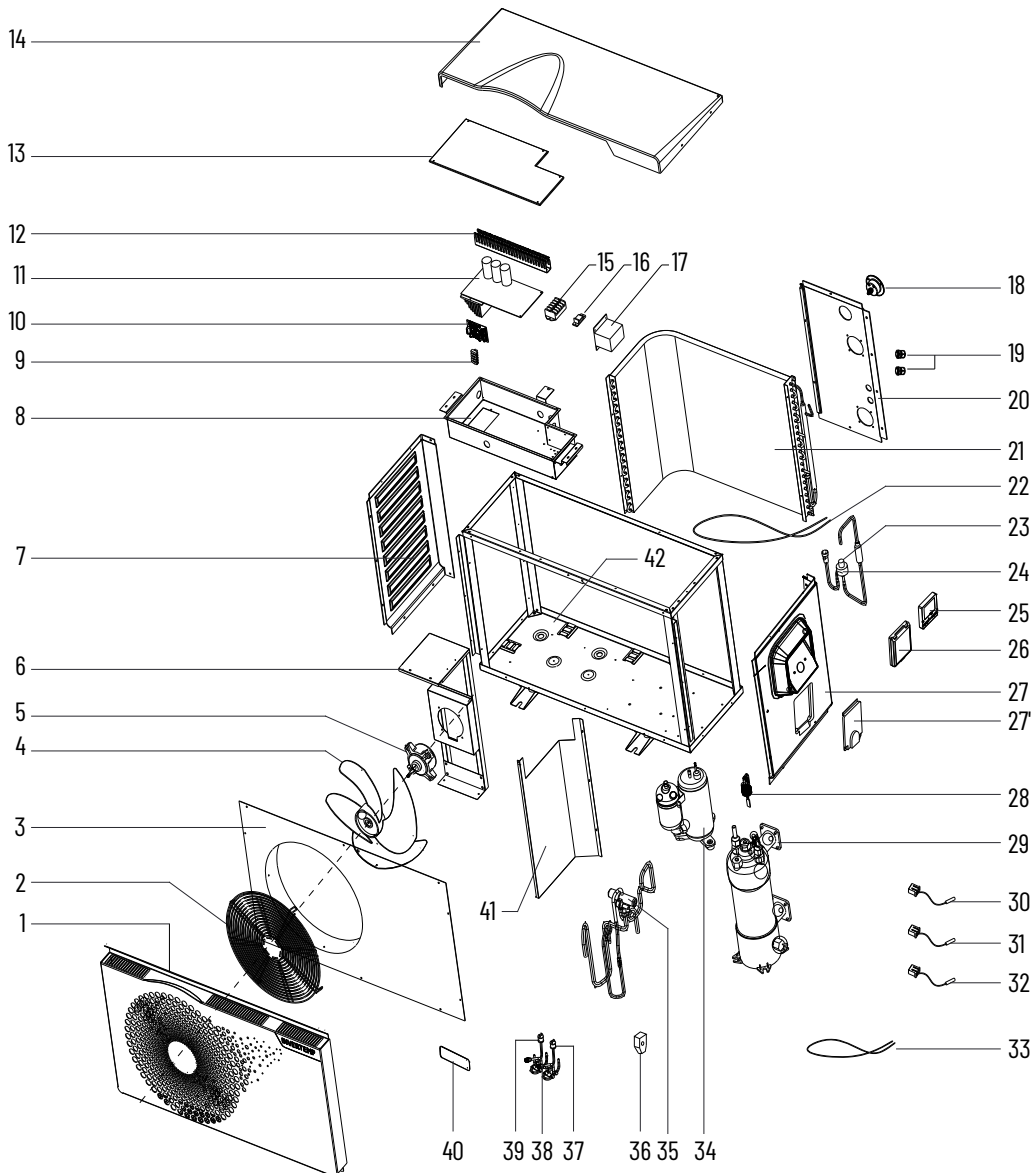

N°	Description
1	Protective grid of the fan
2	Front panel
3	Fan propeller
4	Fan motor
5	Motor support
6	Frame
7	Left panel
8	Board 1 connector
9	Modbus board
10	Electronic board
11	Cable channel
12	Electric casing
13	Cover for electric casing
14	Upper panel
15	Board 2 connector
16	Cable fastener
17	Current limiter
18	Pressure gauge
19	Cable gland Ø19
20	Rear panel
21	Evaporator
22	Rear panel resistance
23	Body of the electronic reducer
24	Coil of the electronic reducer
25	Screen
26	Screen protection
27	Right panel
27	Access hatch
28	Water flow detector
29	Titanium condenser
30	Temperature sensor (evaporator)
	Temperature sensor (aspiration)
	Temperature sensor (water outlet)
	Temperature sensor (water inlet)
31	Temperature sensor (compressor outlet)
32	Ambient temperature sensor
33	Compressor resistance
34	Compressor
35	4-way valve
36	Coil of the 4-way valve
37	Low-pressure pressure switch
38	Schrader valve
39	High-pressure pressure switch
40	Logo plate
41	Separation panel
42	Chassis bottom sheet metal



Pentair International SARL,

Ave. de Sévelin 20, CH-1004 - LAUSANNE, Switzerland

Copyright - Limited license: unless expressly authorised herein, no part of the content of the present document can be reproduced in any form or by any means without the prior written authorisation by Pentair International SRL.