

# Leon Studio Frame™ for Sony BRAVIA XR

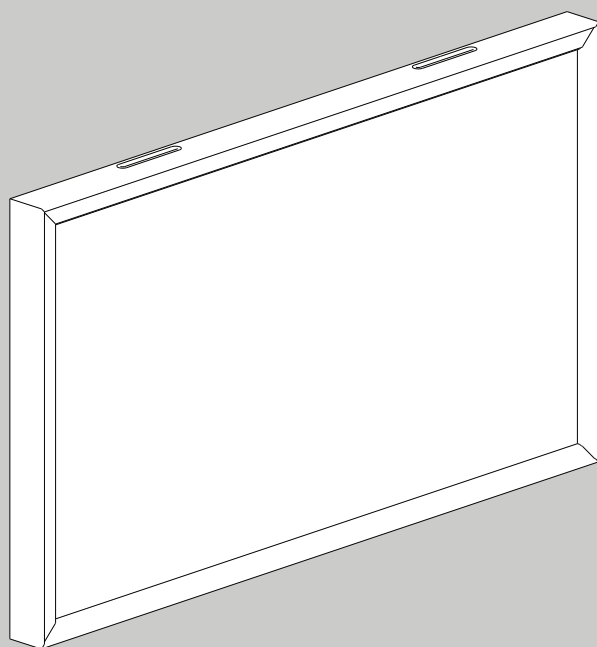

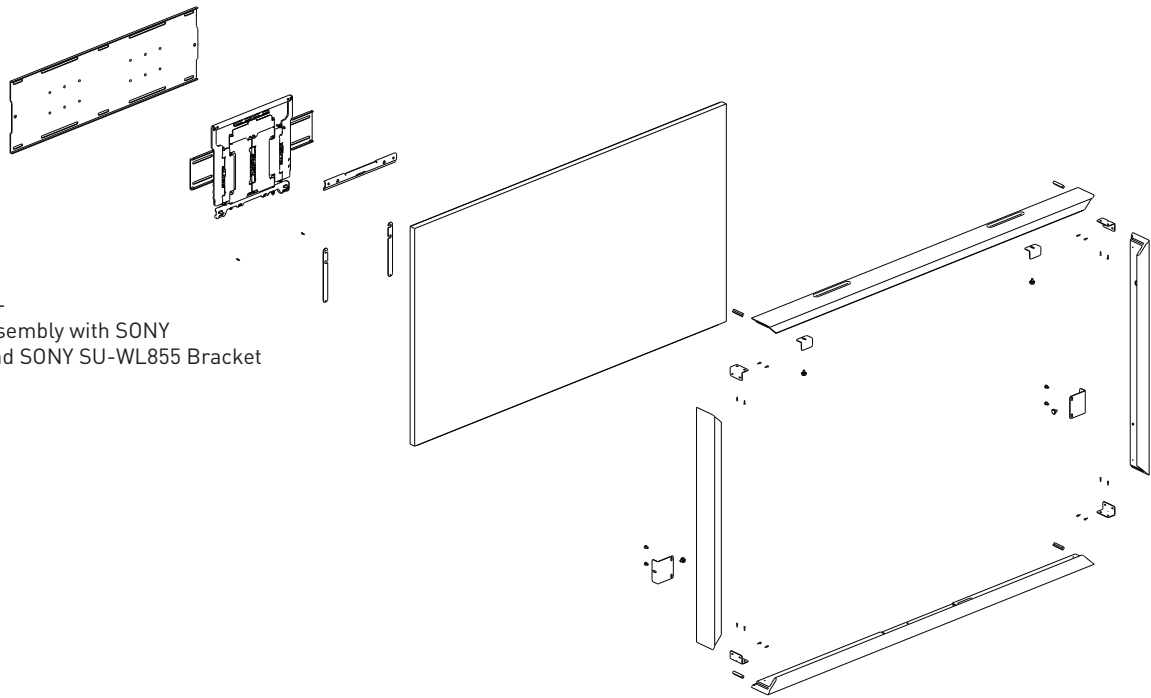





Installation Instructions



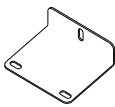



Exploded -  
Frame Assembly with SONY  
Display and SONY SU-WL855 Bracket

## WHAT'S INCLUDED

<p><b>A</b> 16X #6-1/2" Phillips Head Screw</p> 	<p><b>B</b> 4X Corner Brace</p> 	<p><b>C</b> 2X Display Clamp</p> 
<p><b>D</b> 2X Frame Mount Bracket</p> 	<p><b>E</b> 4X 46mm Dovetail Joiner</p> 	<p><b>F</b> 4X M5 x 10mm Phillips Head Screw</p> 
<p><b>G</b> 4X M5 x 10mm Thumb Screw</p> 	<p><b>H</b> 1X Sensor USB Cable</p> 	<p><b>I</b> 2X #4-1/2" Philips Head Screw</p> 
<p><b>J</b> 2X VESA Hem Bar</p> 	<p><b>K</b> 1X App Installation USB</p>	

## TOOLS REQUIRED

<p>Phillips Head Screwdriver (PH2:1-1/2)</p> 	<p>Flathead Screw Driver</p> 
--	--

Drawings not to scale

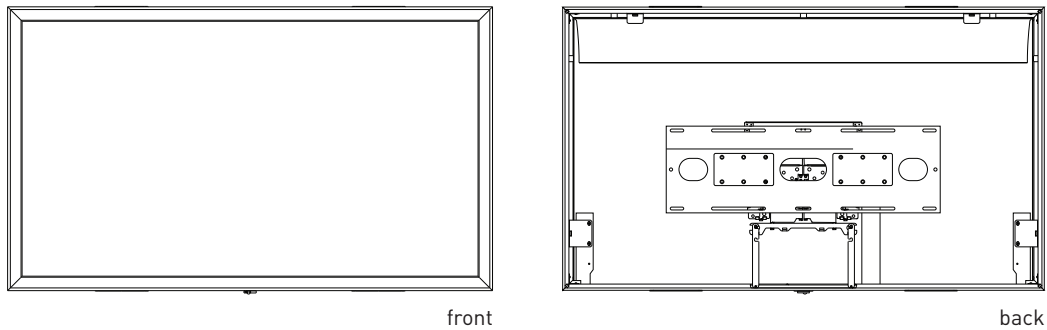

## BEFORE INSTALLATION

**⚠ Mitered corners on your frame can be sharp. Handle with care.**

### Installation Best Practices

Please install and/or uninstall the frame with 2 or more people.

Always remove frame first before removing display from the wall bracket.

Do not apply force to the screen of your display.

Choose an installation location free of physical obstructions behind or within the wall.

We recommend the use of an adhesive when bonding the mitered corners of your frame.

Working near electrical equipment and wires poses an electrocution hazard. Turn off nearby electrical circuits from the breaker. Use a non-contact voltage tester to confirm that the installation location is free of live electrical wires and equipment prior to cutting or drilling into the wall. Contact a qualified electrician before making any modifications to electrical wiring.

Determine the potential hazards of working with hand or power tools and take the appropriate safety precautions. Use personal protective equipment (PPE) as appropriate, including, but not limited to: vision, hearing, and respiratory protection.

Consult local building and/or electrical codes prior to installation of speakers, cabling, or electrical equipment.

Estimated frame assembly time 15-20 minutes. Estimated app installation time 5-10 minutes.

**NOTE: To gain full functionality of your Sony remote control, you will need to add an IR repeater to your installation.**

**SECTION A:** Set up the hardware (steps 1-4)

**SECTION B:** Build the frame (steps 5-8)

**SECTION C:** Hang frame and connect sensors (9-12)

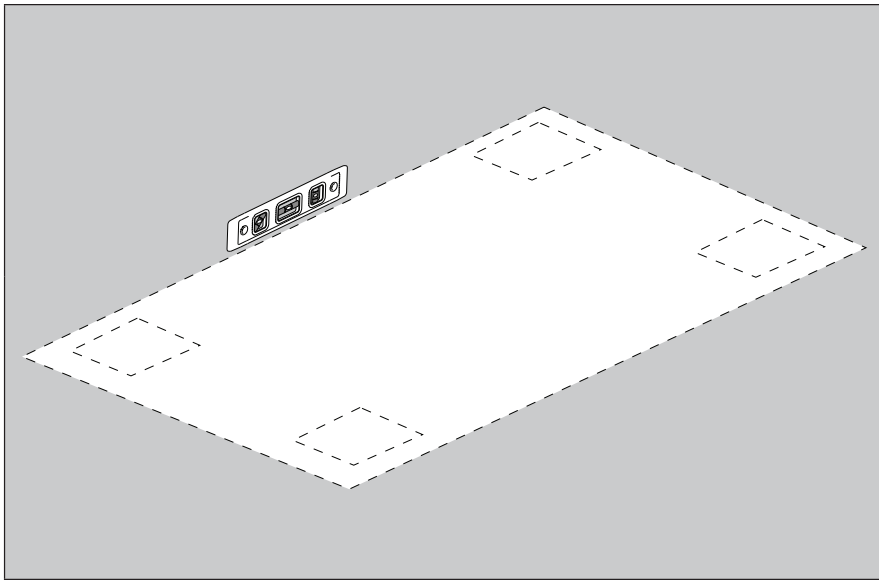

### Step 1 Prepare Your Working Area & Unbox the Frame

Designate a clean, level, non-abrasive surface free from debris and large enough to accommodate your frame assembly.

⚠️ Open box with care to avoid damaging frame

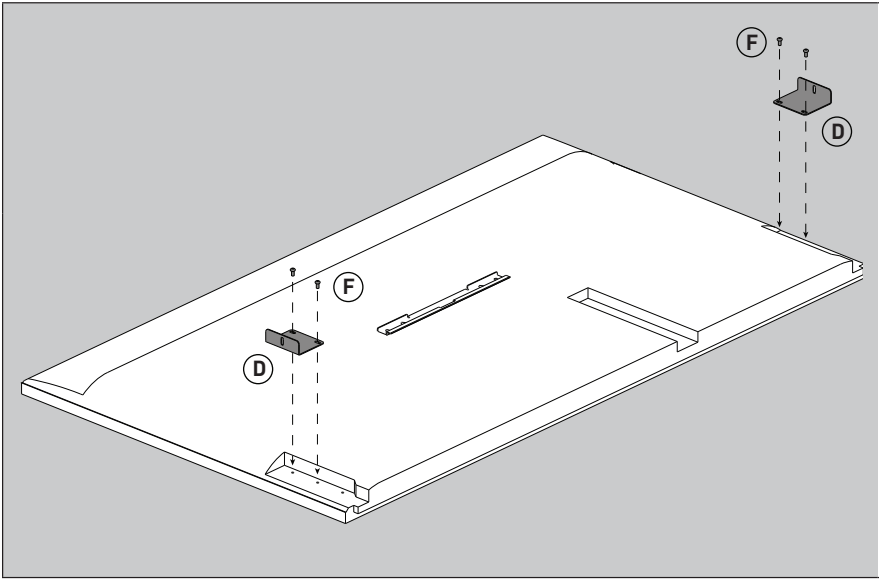

### Step 2 Attach Frame Mount Brackets to TV

Make sure rear plastic panels are removed from the back of the display. Attach both Frame Mount Brackets (D) to the top 2 threaded holes on the display backside using the M5 x 10mm Phillips Head Screws (F). Leave loose for future adjustment.

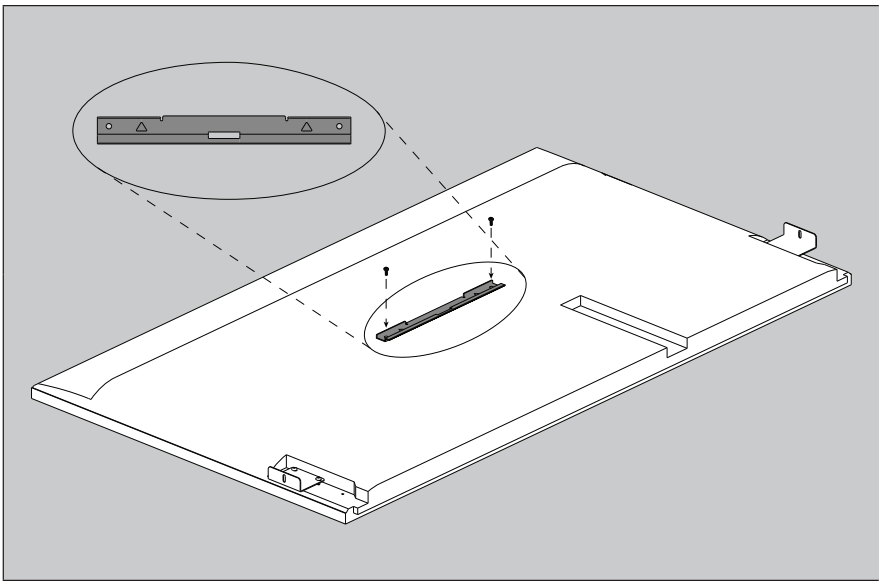

### Step 3 Install Wall Mount Bracket & Mount TV to the Wall

Install the wall mount bracket (SU-WL855 bracket recommended, \*not provided by Leon) and mount TV to wall. Be sure to follow SU-WL855 bracket installation instructions to mount your TV.

⚠️ Brackets can damage the walls

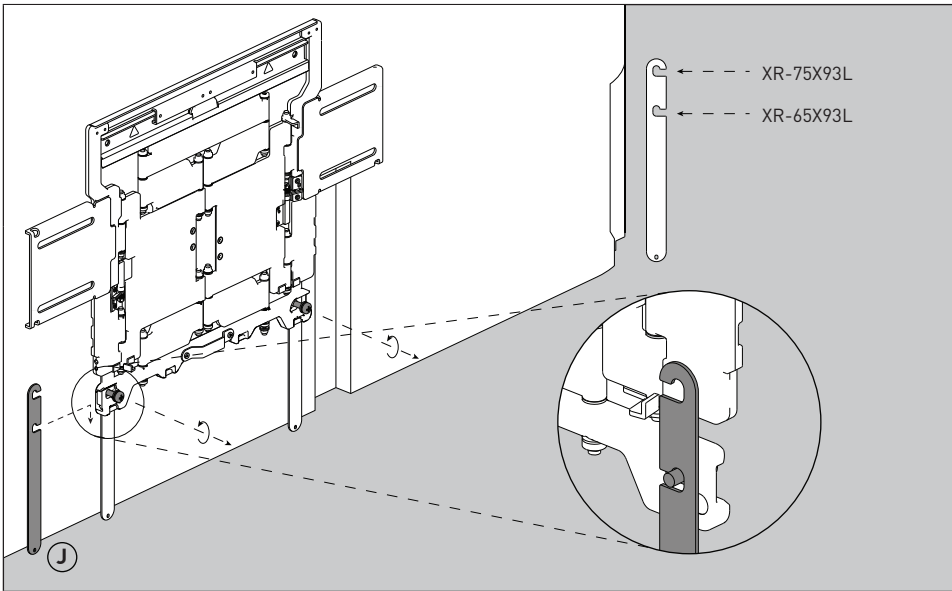

## Step 4 Attach Hem Bars to Display

Install VESA Hem Bars **(J)** to reinforce the bottom of the frame. Loosen the two M6 screws from the back of the SU-WL855 bracket (provided with bracket). This creates clearance between the back of the display and the front of the wall mount to hook your VESA Hem Bars onto the M6 screws as shown. Use the top notch with XR-75X93L display and bottom notch for XR-65X93L display. Retighten M6 screws.

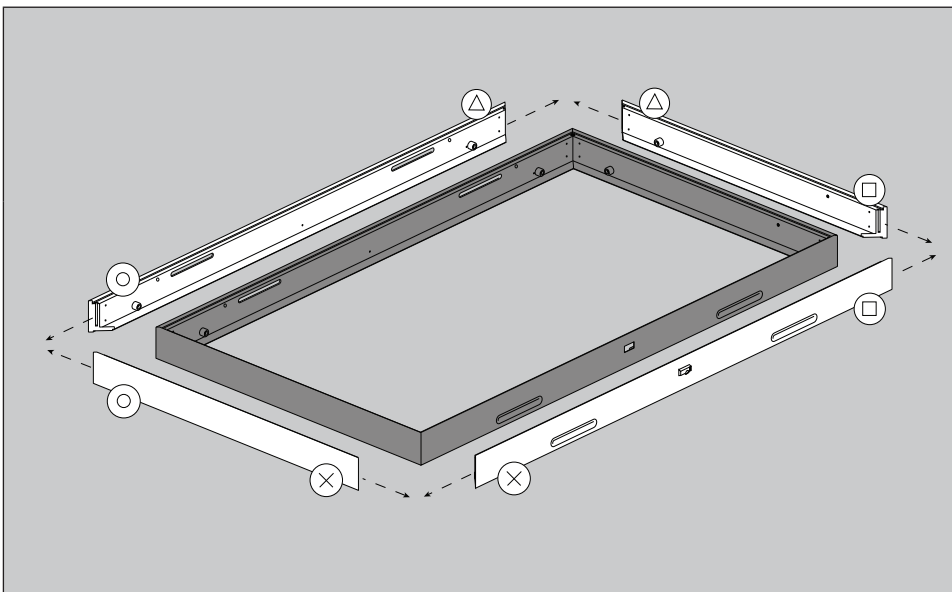

## Step 5 Lay Out Frame

On your clean & level surface, begin frame assembly by lining up all 4 sides of the moulding facing down. Match corners using the symbols. Lightly press the tip of a dovetail joiner **(E)** into each pre-milled pocket paying close attention to front seam alignment of frame. Do not fully insert dovetail joiners yet.

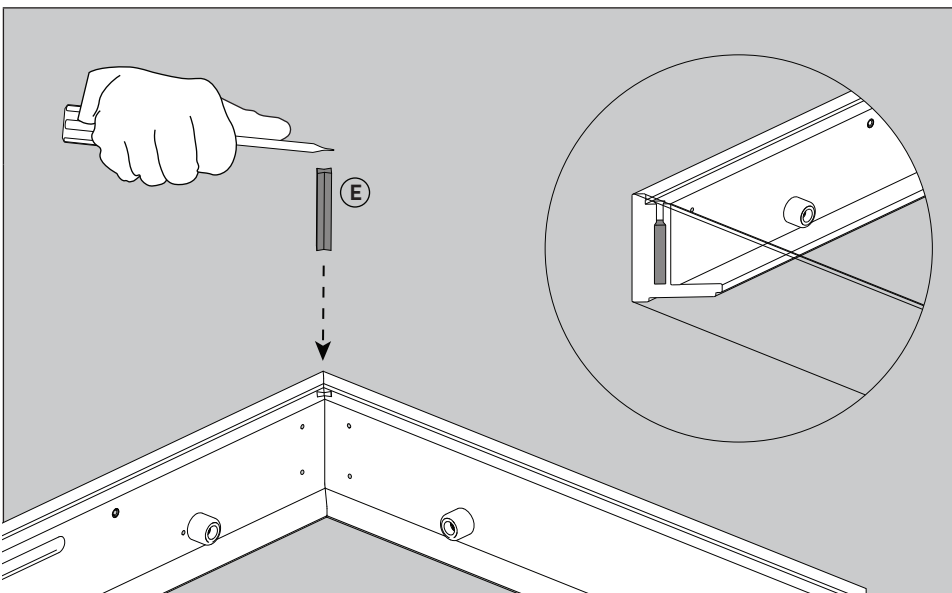

## Step 6 Install Dovetail Joiners

**NOTE:** Make sure all corners are square before installing dovetail joiners.

Drive one dovetail joiner **(E)** to the bottom of the pre-milled pocket in one of the 4 corners of the frame with the tip of a flathead screwdriver. Move to the diagonal corner and drive the second dovetail joiner to the bottom of the pocket. Repeat this step until all 4 corners are complete.

**⚠** Caution when using screwdriver

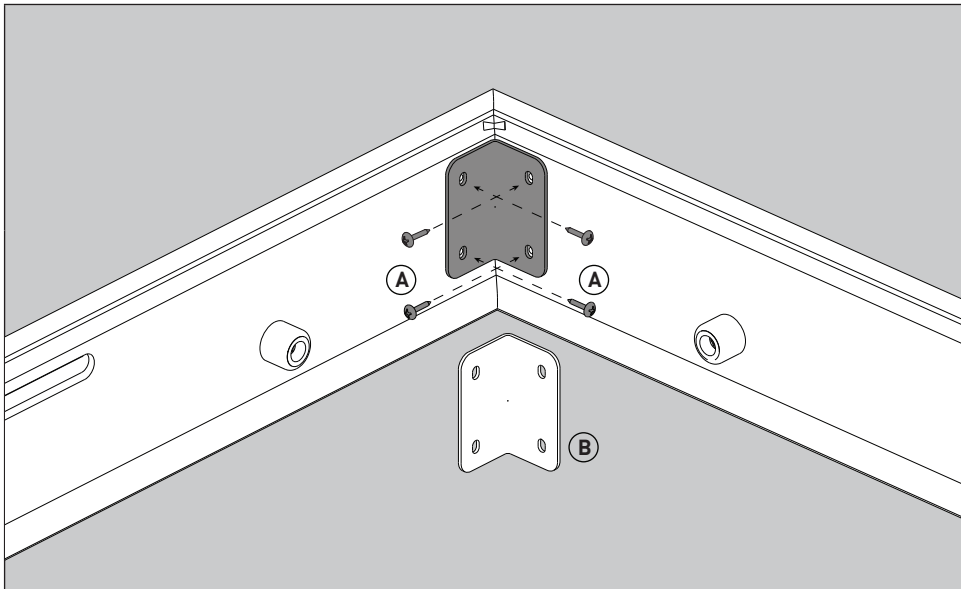

## Step 7 Install Corner Braces

Once dovetail joiners are installed into all 4 corners, make any final adjustments to the corners to ensure proper alignment. Then, while holding the corners together, fasten a Corner Brace **(B)** with the provided #6 x 1/2" screws **(A)** into each of the 4 corners.

⚠ Manual Screwdriver only. Avoid power tools

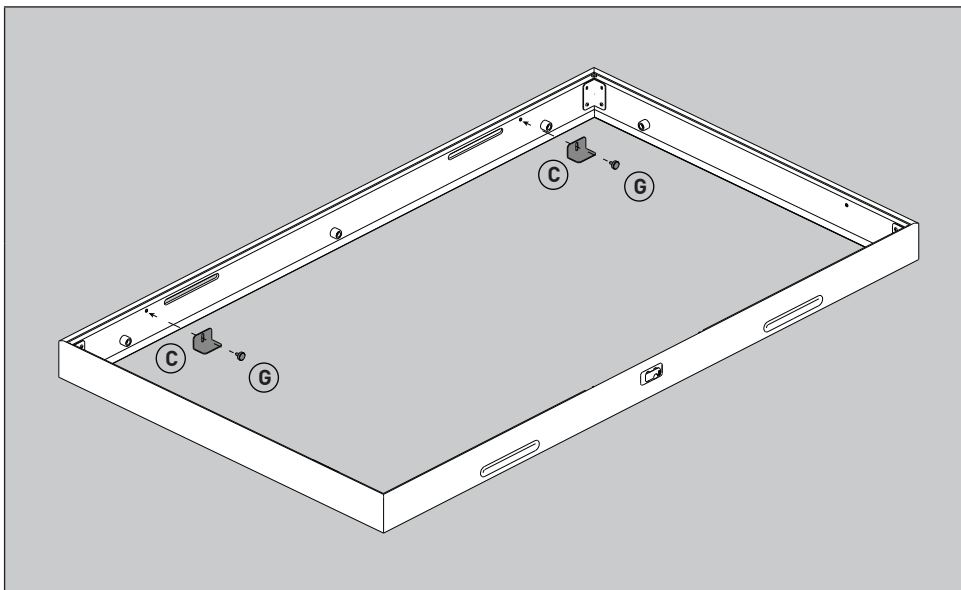

## Step 8 Attach Display Clamps to Top of Frame

Attach 2 Display Clamps **(C)** to the top moulding which can be identified by its 3 rubber bumpers, using the provided M5 Thumb screws **(G)**. Leave loose for adjustment later.

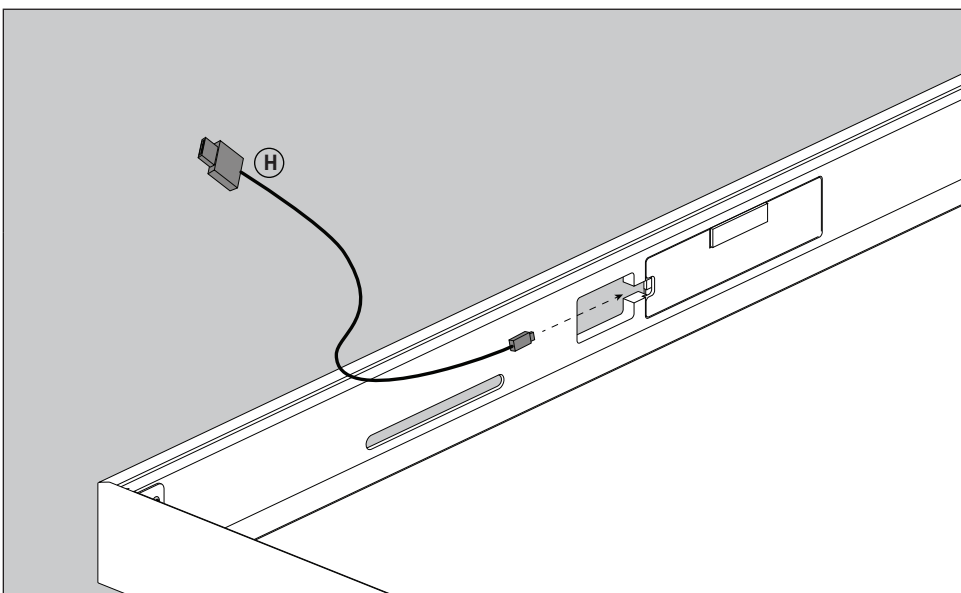

## Step 9 Connect Sensor USB Cable

Connect the micro USB end of the Sensor USB cable **(H)** to the sensor input in the bottom frame. Leave this cable loose until your frame is attached to your TV.

NOTE: USB symbol should be facing up when connecting to sensor input.

⚠ Gently insert micro-USB

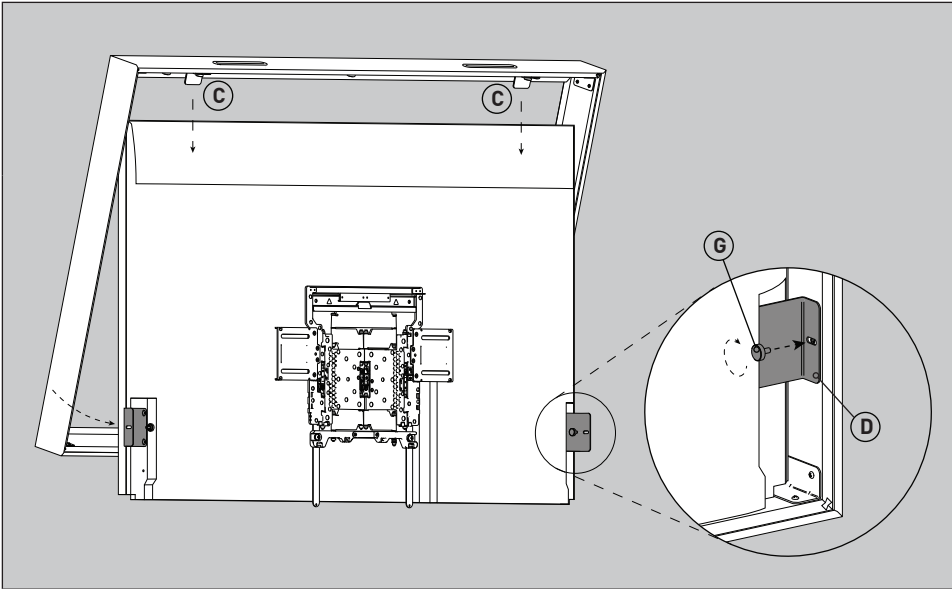

## Step 10 Place Frame onto Display

Place frame onto TV by hooking the Display Clamps **C** on the top moulding of the frame over the top of your display. Then fasten your Frame Mount Brackets **D** to the sides of your frame using the M5 x 10mm Thumb Screws **G**. Adjust Display Clamps and Frame Mount Brackets to ensure the frame is tight to the front & bottom of the display. Tighten M5 x 10mm Philips Screws **F** in the Frame Mount Brackets.

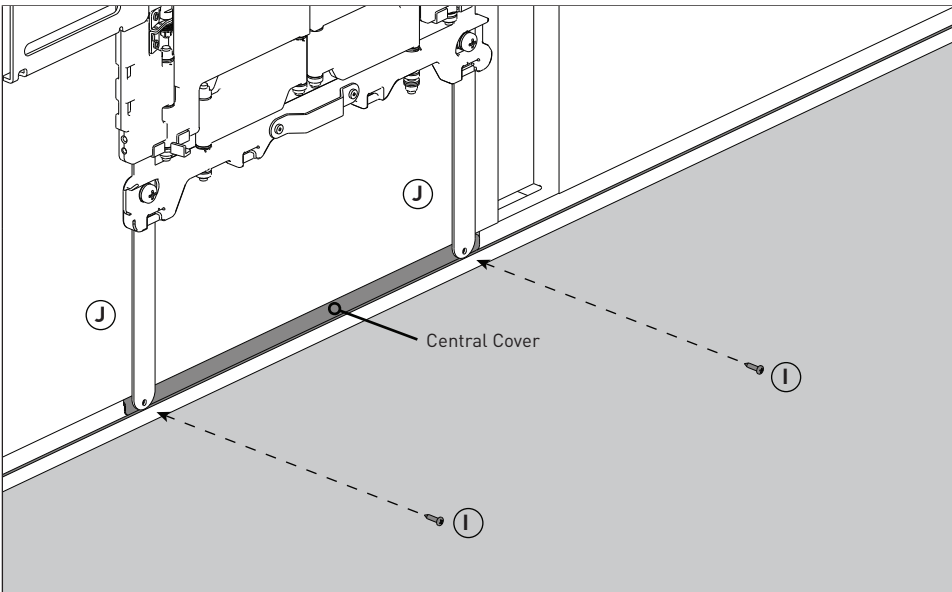

## Step 11 Fasten VESA Hem Bars to Central Cover

**NOTE:** This step is vital to prevent bowing in the middle of your frame

With the frame and display mount in place, lightly push up on the bottom of the frame assembly to align holes in the back of the central cover with the holes at the bottom of both VESA Hem Bars **J**. Install a #4-1/2" screw **I** into the central cover through the VESA Hem Bar and tighten into place.

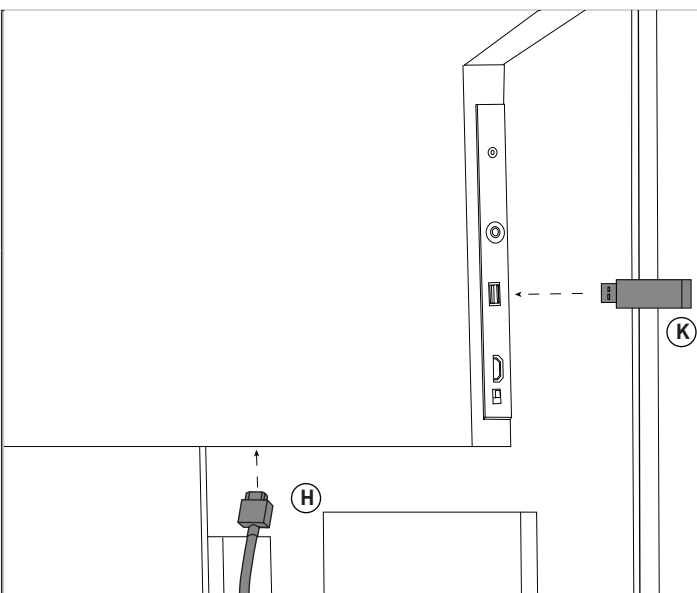

## Step 12 Connect USB Cable & App USB Installation

Route sensor USB cable **H** through channel in the back of the display to the USB port in the bottom of your TV. Then, gather cable slack and neatly tuck into TV's cable management area. Plug the App Installation USB **K** into the USB port on the side of your display. Your Studio Frame installation is complete! Now follow app installation guide to install your Sony Art Frame Gallery.

**NOTE:** To gain full functionality of your Sony remote control, you will need to add an IR repeater to your installation.

## LIMITED WARRANTY ON COMPONENTS:

### **Studio Frame**

Leon warrants to the first end-user purchaser that any Wood Housing / Frame utilized by the Product, when purchased from an authorized Leon Dealer, will be free from manufacturing defects from the date of shipment for a period of one (1) year. If any manufacturing defect exists in the Wood Housing / Frame so long as the customer promptly notifies Leon of the defect within the warranty period and, if requested by Leon, returns the defective part(s), Leon will at its option and expense during the warranty period, either repair the defect or replace the Product with a new or remanufactured Product or a reasonable equivalent.

Note: The Warranty will be void, and Leon will have no responsibility under this Warranty, if Leon or its representatives cannot access any Components to inspect, diagnose problems or repair Product as a result of concealment or inaccessibility of such Products or Components within a building structure. This Warranty only covers failure due to defects in materials and workmanship that occur during normal use and does not cover normal maintenance.

### **EXCLUSIONS & RESTRICTIONS**

TO THE EXTENT PERMITTED BY LAW, THE WARRANTY SET FORTH ABOVE IS IN LIEU OF, AND EXCLUSIVE OF, ALL OTHER WARRANTIES, EXPRESS OR IMPLIED, AND IS THE SOLE AND EXCLUSIVE WARRANTY PROVIDED BY LEON. ALL OTHER EXPRESS AND IMPLIED WARRANTIES, INCLUDING THE IMPLIED WARRANTIES OF MERCHANTABILITY, IMPLIED WARRANTY OF FITNESS FOR USE, AND IMPLIED WARRANTY OF FITNESS FOR A PARTICULAR PURPOSE ARE SPECIFICALLY EXCLUDED. No one is authorized to make or modify any warranties on behalf of Leon.

The warranty stated above is the sole and exclusive remedy and Leon's performance shall constitute full and final satisfaction of all obligations, liabilities and claims with respect to the Product. IN ANY EVENT, LEON SHALL NOT BE LIABLE FOR CONSEQUENTIAL, INCIDENTAL, ECONOMIC, PROPERTY, BODILY INJURY, OR PERSONAL INJURY DAMAGES ARISING FROM THE PRODUCT, ANY BREACH OF THIS WARRANTY OR OTHERWISE. THE RIGHT TO RECOVER DAMAGES WITHIN THE LIMITATIONS SET FORTH IS YOUR EXCLUSIVE ALTERNATIVE REMEDY IF THE LIMITED REMEDY OF REPAIR OR REPLACEMENT FAILS ITS ESSENTIAL PURPOSE.

This warranty statement gives you specific legal rights, and you may have other rights which vary from state to state. Some states do not allow the exclusion of implied warranties or limitations of remedies, so the above exclusions and limitations may not apply. If your state does not allow disclaimer of implied warranties, the duration of such implied warranties is limited to the period of Leon's express warranty.

### **Warranty Period for this Product:**

This warranty begins on the date on the original sales receipt or invoice or other satisfactory proof of purchase.

### **Additional Limitations and Exclusions from Warranty Coverage:**

The warranty described above is non-transferable, applies only to the initial installation of the Product, does not include installation of any repaired or replaced Product, does not include damage to allied or associated equipment which may result for any reason from use with this Product, such as (a) use of incorrect line voltage fuses or circuit breakers; (b) failure to install, maintain and operate the Product and Components pursuant to the installation and operating instructions provided by Leon and the applicable provisions of the National Electrical Code and of the Safety Standards of Underwriter's Laboratories; (c) use of incompatible devices or accessories; (d) improper or insufficient ventilation; (e) unauthorized repairs or adjustments or alterations; (f) vandalism; (g) an act of God, such as fire, lightning, flooding, tornado, earthquake, hurricane or other problems beyond Leon's control; or (h) direct exposure to corrosive materials, and does not include labor or parts to repair damage caused by accident, mishandling, disaster, negligence, improper installation, misuse (including, but not necessarily limited to, overdriving the Components, exposing the Product to excessive heat or cold or humidity, direct water spray or immersion), commercial use, abuse, negligence, or normal wear and tear, or from service or repair which has not been authorized by Leon. This warranty also excludes products that have had their housings opened or tampered with, products that are missing or have altered serial numbers, problems caused by using third party accessories, parts or components, and normal cosmetic deterioration caused by environmental conditions, damage as a result of the Product being improperly stored, left unopened in the shipping box or not installed and/or tested within 14-days of receipt of the unit. The reseller must inspect the Product upon receipt and promptly inform Leon of any damage.

### **Obtaining Authorized Service:**

To qualify for the warranty, you must contact your authorized Leon Dealer/Installer or call Leon Customer Service at (888) 213-5015 within the warranty period, obtain a return merchandise number (RMA), and deliver the Product to Leon in suitable packaging, shipping prepaid during the warranty period, together with the original sales receipt, invoice or other satisfactory proof of purchase.



# Questions?

For additional support, call customer service  
1 (888) 213-5015 | Mon - Fri 8 am-6 pm EST



Leon is a registered trademark of Leon Speakers, Inc ©2023

REF-25-132\_Studio\_Frame\_20240226