

Read this manual before operation

Installation & Operation Manual

Gas Charbroiler

HRC-14/24/36/48



If you smell gas, follow the instructions provided by the gas supplier.

Do not try to light the burner; do not use a telephone within close proximity.

FOR YOUR SAFETY

Do not store or use gasoline or other flammable vapors or liquids in the vicinity of this or any other equipment.

⚠ WARNING Improper installation, adjustment, alteration, service or maintenance can cause property damage, injury or death. Read this installation, operating and maintenance instructions thoroughly before installing or servicing this equipment.

Dear Customer & User,

Thank you for purchasing our appliance. Before use and operation, please read and familiarize yourself with the following operating and safety instructions. **SAVE THESE INSTRUCTIONS FOR FUTURE REFERENCE.** Save the original box and packaging. Use this packaging to ship the equipment if repairs are needed.

This manual contains important information, please read the manual thoroughly prior to equipment set-up, operation and maintenance. Failure to comply with regular maintenance guidelines outlined in this manual may void the warranty.

The user's manual should be always available for operation. So make sure this manual book is properly placed. We have the full authority to reserve the further technical changes of the device, in the scope of further performance improvement characteristic development.

WARNINGS

- Do not store or use gasoline or other flammable vapors or liquids in the vicinity of this or any other equipment.
- Improper installation, adjustment, alteration, service or maintenance can cause property damage, injury or death.
- Read the installation and maintenance instructions thoroughly before installing or servicing this equipment.
- Have the equipment installed by a qualified installer in accordance with all federal, state and local codes.
- Do not install or use without all 4 legs.
- This equipment is for use in non-combustible locations only.
- Do not obstruct the flow of combustion and ventilation air.
- Do not spray controls or the outside of the equipment with liquids or cleaning agents
- Allow for hot parts to cool before cleaning or moving.
- This equipment should only be used in a flat, level position.
- Do not operate unattended.
- Any loose dirt or metal particles that are allowed to enter the gas lines on this equipment will damage the valve and affect its operation.
- If you smell gas, follow the instructions provided by the gas supplier. Do not try to light the burner; do not use a telephone within close proximity.
- Never attempt to move grate while cooking.

Product parameters table

Model No.	HRC-14	HRC-24	HRC-36	HRC-48
Dimension(WxDxH)	355*771*472mm	610*771*472mm	915*771*472mm	1220*771*472mm
Power	40000BTU	80000BTU	120000BTU	160000BTU
Burner	2	4	6	8
N.W.	58kg	110kg	145kg	183kg

Product Structure

HRC-14

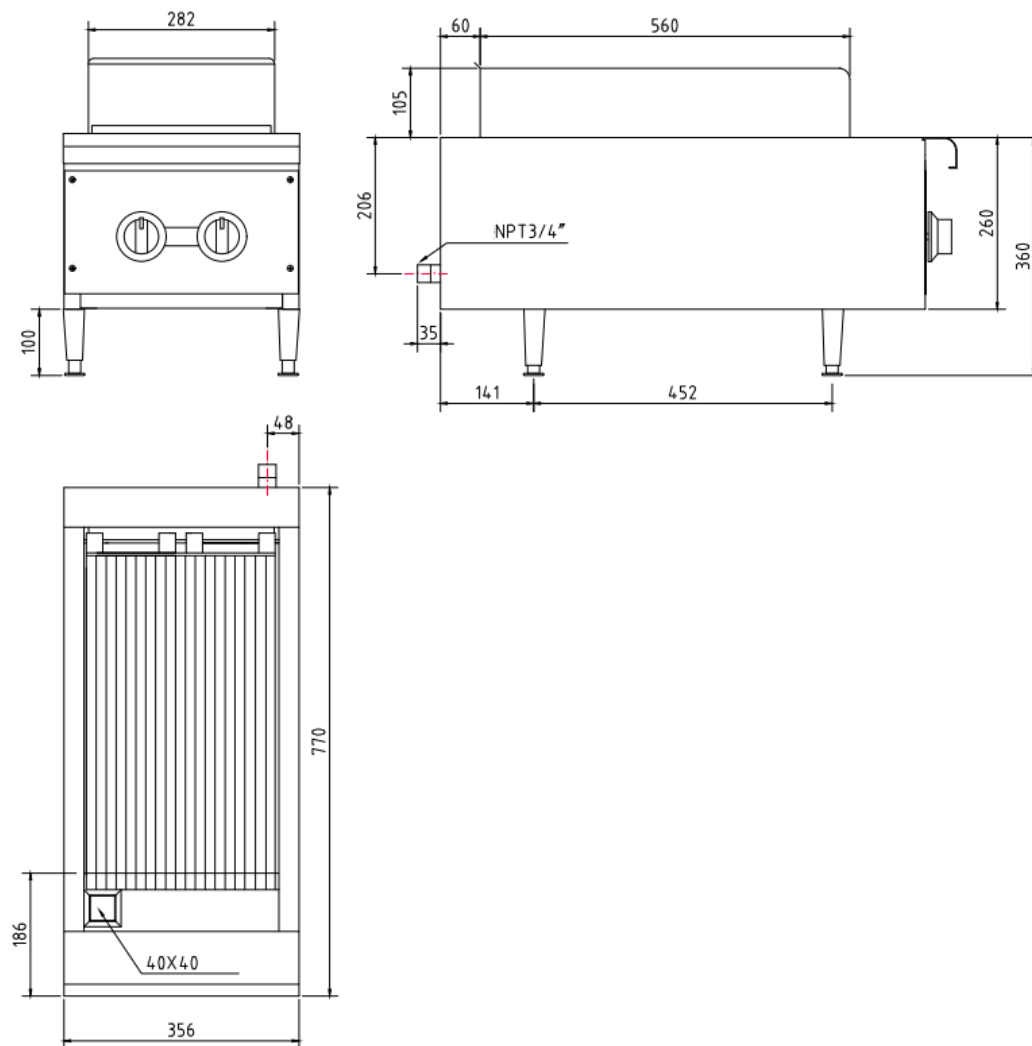

HRC-24

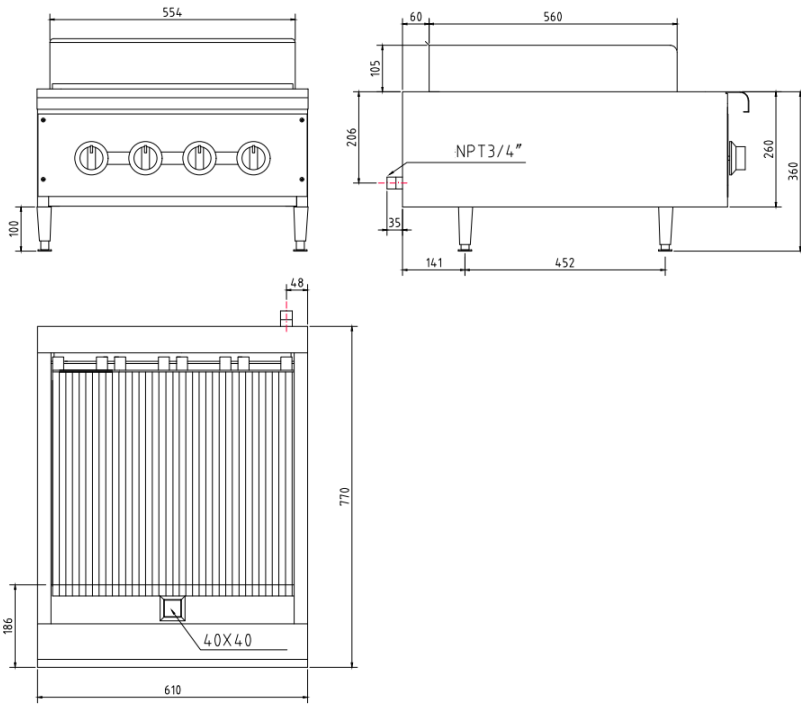

HRC-36

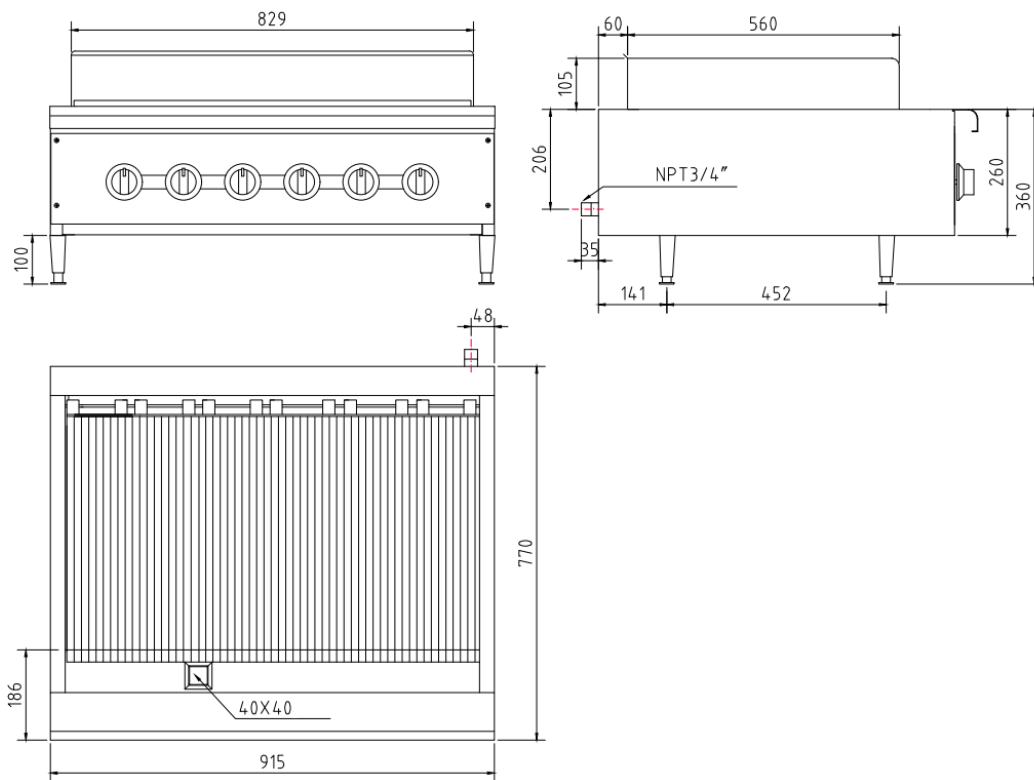

HRC-48

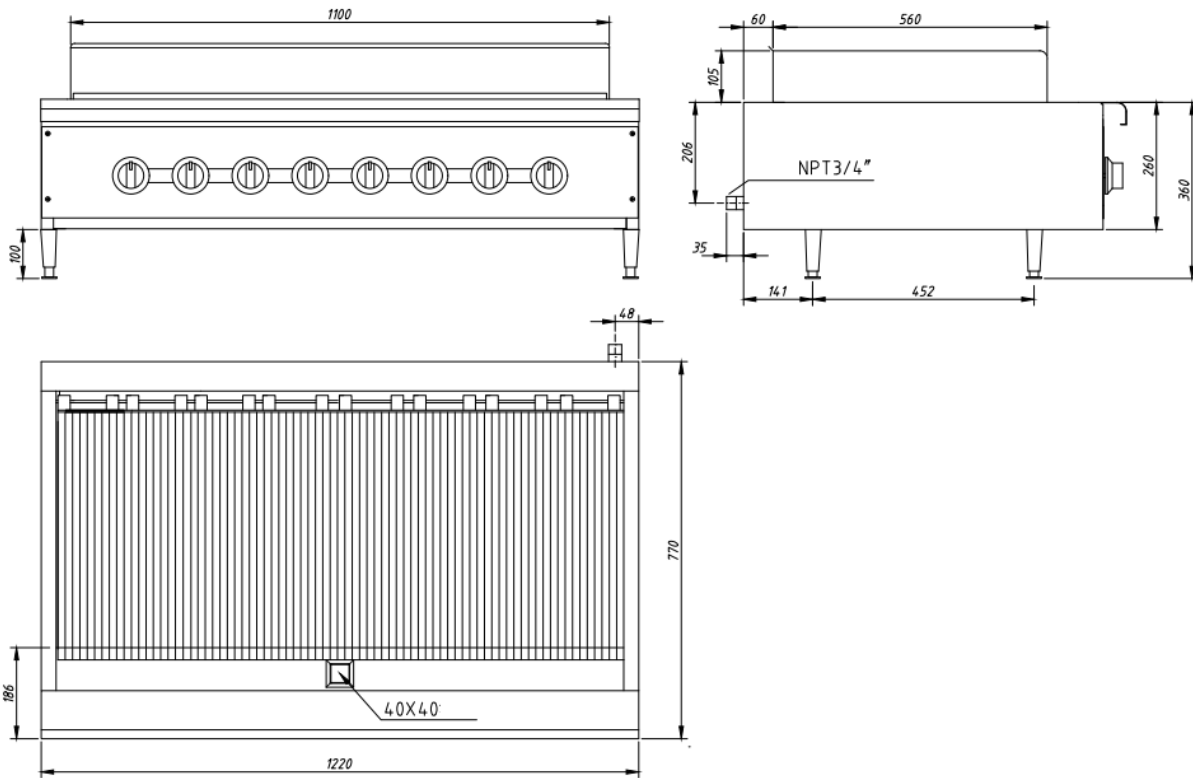

INSTALLATIONS

UNPACKING & INSPECTION

Carefully remove the appliance from the carton. Remove all protective plastic film, packing materials and accessories from the appliance before connecting performing any installation procedure. Carefully read all instructions in this manual and the Installation Instruction Sheet packed with the appliance before starting any installation.

Read and understand all labels and diagrams attached to the appliance.

Carefully account for all components and accessories before discarding packing materials. Store all accessories in a convenient place for later use.

SETUP

This appliance is designed for use in non-combustible locations only. Setup the charbroiler only on a firm, level, non-combustible surface.

Verify local codes for requirements. Concrete, tile, terrazzo or metal surfaces are

recommended. Metal or tile over combustible material may not meet code for non-combustible surfaces.

Clearances to non-combustible surfaces must be maintained. Maintain 0" from side and rear to non-combustible walls, and 4" from non-combustible counter as established by provided 4" legs. Maintain adequate clearances for cleaning and proper operation.

The charbroiler must be installed in an area with sufficient make-up air for proper combustion, and must be installed such that the flow of combustion and ventilation air will not be obstructed.

For servicing, manufacturer recommends 6" clearance from rear of the appliance to wall. Install adjustable legs, one on each corner of the appliance, in the holes provided. Verify that the unit sits firmly ON ALL FOUR LEGS. With the adjustable legs, adjust as required to level the appliance. All four legs must be adjusted to firmly contact the floor in order to prevent tipping. When used with an exhaust fan, special precautions must be observed to avoid interference with the operation of the charbroiler, such as drafts and air starvation.

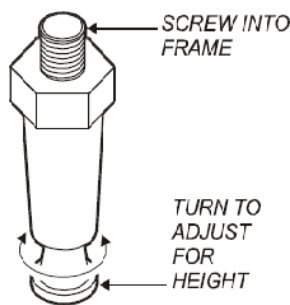

GAS APPLIANCE CODE COMPLIANCE

The installation of gas piping from the outlet side of the gas meter or service regulator to the griddle must be performed by a technician qualified and certified or licensed to install gas-fired equipment.

A licensed and qualified technician must perform the initial startup and adjustment of this appliance.

The installation of this gas-fired appliance must conform to local codes.

IT IS THE RESPONSIBILITY OF THE INSTALLER TO ENSURE

THIS GAS GRIDDLE INSTALLATION CONFORMS TO ALL APPLICABLE CODES AND ORDINANCES.

The venting of this appliance must not be obstructed, nor may such venting interfere with the flow of combustion air required for proper operation of the gas burners.

Additionally:

1.The gas supply line used to connect the charbroiler to the gas supply system must be black iron pipe, or other material as approved by local ordinance for gas piping.

2.Gas supply piping must be inside 3/4” diameter or greater.

3.Use pipe sealant made specifically for gas piping on all pipe joints. Apply sealant sparingly to the male threads only.

Sealant must be resistant to the action of LP gas.

4.Verify that all supply piping is clean and free of obstructions, dirt, chips and pipe sealant compound prior to installation.

5.All pipe joints must be checked for leaks before lighting. Leak checks should be performed with a soap and water solution. NEVER CHECK FOR LEAKS WITH AN OPEN FLAME.

INSTALLING THE CHARBROILER

Refer to the nameplate. Verify the fuel type and pressure, which must match the nameplate specifications. Connecting the charbroiler to the wrong fuel type and/or pressure will compromise the safety and/or performance of the appliance.

BE SURE TO MAINTAIN REQUIRED CLEARANCES TO COMBUSTIBLE SURFACES.

The charbroiler must be placed in its final operational position and leveled front-to-back and side-to-side, with a spirit level, prior to beginning the gas piping installation. Re-check the level of the unit at the conclusion of the gas piping installation.

Each gas charbroiler is supplied with a separate gas pressure regulator, which must be installed on the manifold pipe protruding from the rear of the griddle. Ensure that the regulator is installed

such that the flow arrow stamped on the body of the regulator points toward the griddle. Failure to properly install the supplied regulator will result in an extremely hazardous condition.

A moisture trap (drip leg) consisting of a tee, 4” nipple pointing down, and cap must be installed upstream of the gas pressure regulator.

A manual gas shut-off valve may be required by local codes and is, in any case, strongly recommended. The shut-off valve must be installed between the gas supply piping and the gas pressure regulator.

It is the responsibility of the gas piping installer to identify the code requirement for a shut-off valve.

Shut-off valves, moisture trap and all associated piping must be supplied by the gas piping installer.

SET GAS PRESSURE:

Set the suitable gas pressure regulator.

SET PILOT FLAME:

The pilot adjustments are located between the control valves for each set of burners. The right valve controls the front pilot; the left valve controls the rear pilot.

Using a small, flat-blade screwdriver, turn the screw clockwise to decrease the flame size, or counter-clockwise to increase the flame size.

Adjust the pilot flame to 1/4" high. Test for operation: inside and outside sections of the burner must light without undue delay. Drafty conditions may require a higher flame to allow the pilot to remain lit.

ADJUST BURNER FLAME:

Remove all burner control knobs, then remove the front panel. Turn an individual burner on. The right knob controls the front burner; the left knob controls the rear burner.

Loosen the locking screw on the shutter.

Turn the shutter to admit more or less air as required. Adjust the air shutter until the flame is mostly blue in color.

Tighten the locking screw when finished. Replace the front panel and all knobs before returning the unit to service.

GAS CONVERSION:

• Conversion from Natural Gas to Liquid Propane (LP) or vice versa may only be performed by the factory or its authorized service agent. In case of troubleshooting, ensure the correct orifice sizes of the spuds have been provided.

- Natural Gas Orifice is # 45
- Liquid Propane Gas Orifice is #54
- Orifice size is marked on the spud

OPERATION

Carefully read the description of the charbroiler operation on the specification sheet.

Do NOT use this appliance if it has been submerged in water.

Call a qualified technician to examine the appliance and to service or replace any component which has been submerged. Burners which have been allowed to become wet must be thoroughly dried before use.

For initial startup, and any time the gas supply has been shut-off, it may take several minutes to light the pilot while air in the piping and manifolds is purged.

The burner control knobs must be turned by hand only. Never use tools to turn the control knob. If the knob will not turn by hand, DO NOT attempt to force or repair it. Contact your manufacturer for repairs. Forced or improperly repaired valves pose the risk of fire and or explosion.

LIGHTING THE PILOT FLAME

Before lighting the pilot light, smell all around the appliance area for gas. Be sure to smell near floor level because some gas is heavier than air and will settle to the floor.

The pilot light must be lighted by hand:

Remove grates. Turn all control knobs to the full OFF position. Wait 5 minutes.

The pilot is located adjacent to the burner, and is accessible from the top of the unit.

Be sure the gas shut-off valve is ON and the appliance has had time for the air to be purged from the lines. Attempt to light the pilot every 15 seconds after the gas valve is turned on.

Light the pilot with a long match or fireplace lighter. DO NOT use a cigarette lighter.

Reinstall grates

SHUT DOWN INSTRUCTIONS

Turn all burner knobs to OFF.

Turn all pilots OFF.

Turn the main gas supply OFF.

Failure Analysis & Trouble Shooting:

SYMPTOM	POSSIBLE CAUSE	SUGGESTED REMEDY
Portions of a burner won't light or	Burner wet or flame opening(s) clogged	Clean and dry burner
Burners won't light	Gas supply off	Check main / unit gas valves
	Air in lines	Turn gas valve on. Attempt to light pilot every 15 sec.
	Pilot valve not lit	Turn off gas - allow unit to vent for 5 minutes. Turn gas back on and light pilot
One burner assembly won't light	Control not on	Turn temperature control to ON Set to desired setting when lit
	Water in burner	Remove burner and dry thoroughly
	Damaged temperature control, Burner or other internal component	Contact manufacturer for repairs
Pilot will not light	Gas supply off	Check main / unit gas valves
	Air in lines	Turn pilot valve on. Attempt to light pilot every 15 sec.
	Pilot valve not on	Turn pilot valve on / adjust
Burner not hot enough	Temperature control not set	Adjust for desired temperature
	Shutter or nozzle out of adjustment	Contact qualified technician for adjustment
	Damaged temperature control, burner or other internal component	Contact manufacturer for repairs

Exploded Drawing

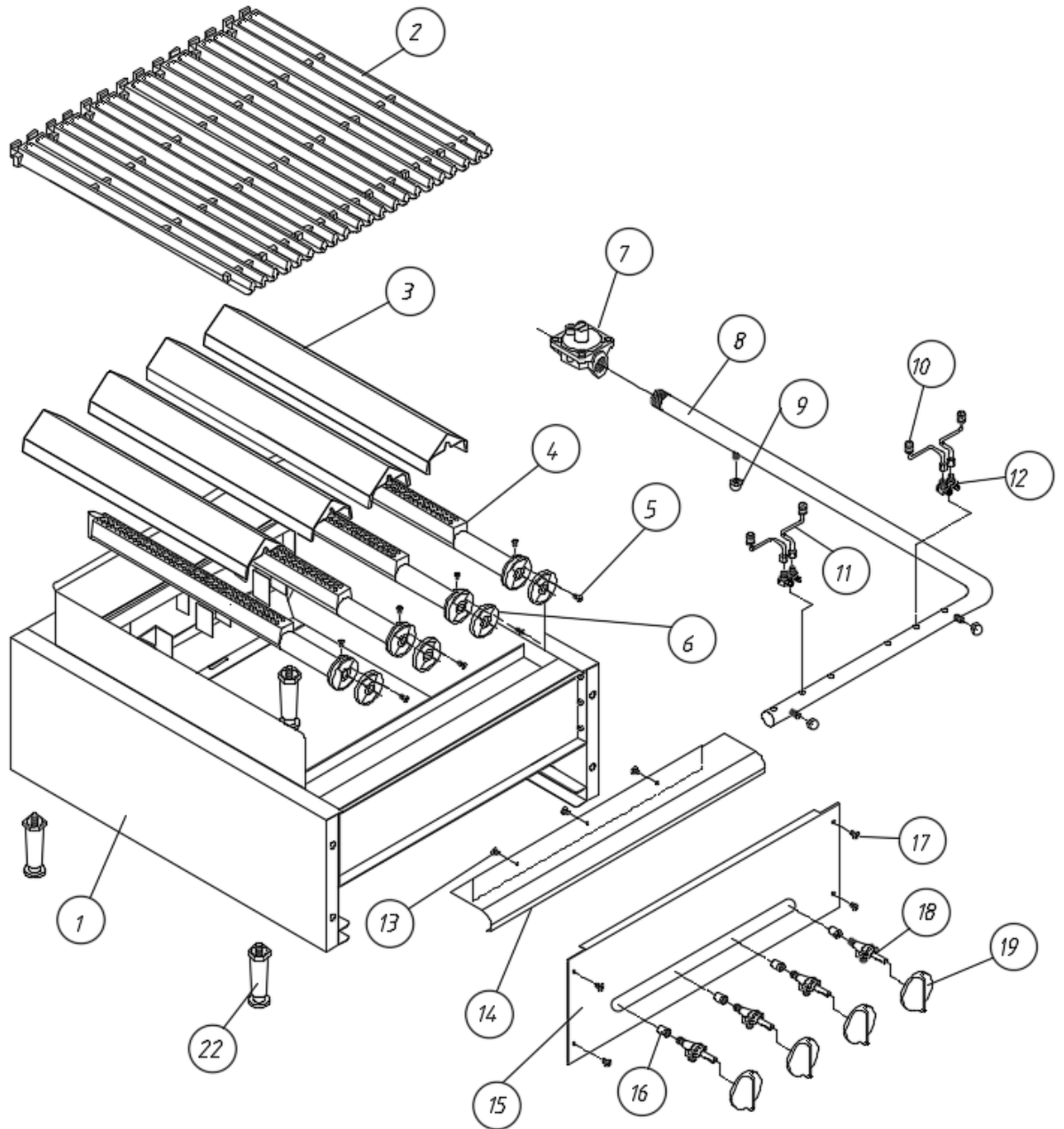

Part List

Ref.No.	Description	Ref.No.	Description
1	Plate class	12	AP6 air supply valve
2	Grate	13	Screw
3	Radiant	14	Plate class
4	Burner	15	Plate class
5	Screw	16	Nozzle
6	Air door	17	Screw
7	Regulator	18	Gas Valve
8	Inlet pipe	19	Knob
9	Nut	20	
10	Pilot	21	
11	Pilot air pipe	22	Adjustable foot