



KV80-3 & KV100-3

WET & DRY VACUUM CLEANER

Instruction Manual

Read instruction manual before use!

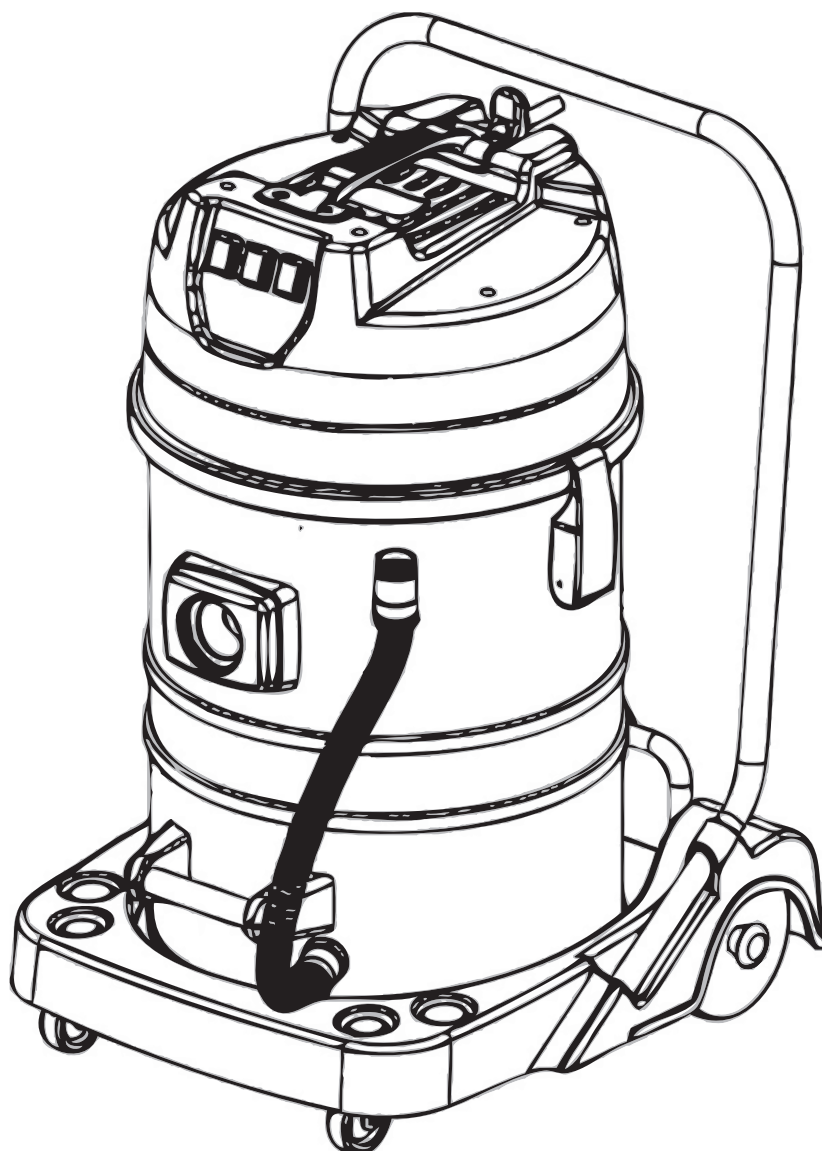

Equipmart Ltd
Kiam House
Birchill Road
Knowsley Ind. Park North
Merseyside
L33 7TD
United Kingdom



T: 0044 151 548 5500
F: 0044 151 548 5599

© Equipmart Ltd
www.kiamproducts.co.uk

1. Safety Instructions

WARNING!

To reduce risk of fire, electric shock, or injury, please read and follow all safety instructions and caution markings before use. This vacuum cleaner is designed to be safe when used for cleaning functions as specified. Should damage occur to electrical or mechanical parts, the cleaner and/or accessory should be repaired by a Kiam Authorised service agent or the manufacturer, before use, in order to avoid further damage to the machine or physical injury to the user.

Read and follow all safety instructions:

- Before using the machine make sure that the frequency and voltage shown on the rating plate corresponds with the mains voltage. (240 volt / 50 Hz)
- Do NOT leave the machine when it is plugged in. Always unplug from the socket when not in use and before maintenance.
- Do NOT use with damaged electrical cable or plug. To unplug, grasp the plug, not the cable. Do not handle plug or machine with wet hands. Turn off all controls before unplugging.
- Do NOT pull or carry the machine by the cable, use the cable as a handle, close a door on the cable or pull the cable around sharp edges or corners. Keep cable away from heated surfaces.
- Keep hair, loose clothing, fingers and all parts of the body away from openings and moving parts. Do not put any objects into openings or use with the inlet blocked. Keep openings free of dust, lint, hair and any debris that could reduce the flow of air.
- Do NOT use this appliance for vacuuming dust which maybe considered hazardous to health.
- Do NOT use to pick up flammable or combustible liquids, such as petrol, or use in areas where they maybe present.
- Do NOT pick up anything that is burning or smoking, such as cigarettes, matches or hot ashes.
- The appliance is not intended for use by young children. Young children should be supervised to ensure that they do not play with the machine. Use extra care when cleaning on stairs.
- If the cleaner is not working properly or has been dropped, damaged, or dropped into water, return it to a Kiam service center.
- Use only as described in this manual and only with the manufacturer's recommended attachments.
- Wash the dust filter with warm water and cleanser and then dry before reusing. Do NOT use a wet dust filter.

2. Starting And Operating The Machine

Check that all power switches are in the off position. Connect the suction hose into the suction inlet of the machine by pushing the hose forward until it clicks in to place at the inlet (to release the hose from machine just push the release button downwards and then pull out the hose). Then connect the two stainless steel tubes with the hose connector and twist the tubes in order to ensure that they are properly fitted. Select a nozzle suitable for your application and attach it to the tube. Connect the power plug into a mains electrical outlet. Push the power switch to the on position to start the motor. Each motor is independently switched.

NOTE: For wet pick up

Remove the dry dust bag. The machine is equipped with a float valve that shuts off the airflow through the machine when the maximum liquid level is reached. You will then hear a noticeable change of sound from the motor and notice that the suction power decreases. When this occurs switch the machine off, disconnect the machine from the socket and empty the tank.

3. Emptying After Wet Pick Up

WARNING

Before emptying the tank, unplug the vacuum cleaner. Always fully empty and clean the container and the float system after picking up liquids. Never pick up liquid without the float system installed in the machine.

Emptying via drain hose:

Detach the drain hose from the bracket by pulling the drain hose away from the machine. Place the end of the drain hose over a drain and remove the plug from drain hose. Gravity will then drain the liquids from the tank.

Emptying via tank:

Release the two latches holding the head unit in place and remove it. The suction hose can remain attached whilst emptying the tank. To avoid movement of the trolley, place one foot at the base part of the trolley. Grasp the handle at the bottom of the tank, then tilt the container backwards to pour the liquids out.

Clean the float valve and basket with a damp cloth before the head unit is refitted to the tank. When refitting the head unit make sure the switches are located in the direction towards the suction inlet. Secure with the latches.

4. Emptying After Dry Pick Up

WARNING

Before checking the dust bag, unplug the vacuum cleaner.

Release the two latches holding the head unit in place and remove it. Check the dust bag and replace if necessary. Refit the head unit onto the tank and secure with the latches. Never pick up dry material without dust bag fitted in the machine. For replacement dust bags, visit www.kiamproducts.co.uk.

5. After Use

Remove the plug from the socket when machine is not in use. Wind up the electrical cable starting from the machine end to avoid kinks. The power cable can be wound up around the hooks located on the head unit.

6. Warranty



The manufacturer provides warranty in accordance with the legislation of the customer's own country of residence with 12 months starting from the date on which the appliance is sold to the end users.

The warranty only covers defects in material or workmanship.

Repairs under warranty may only be carried out by an authorized service centre. When making a claim under the warranty, proof of purchase (with purchase date) must be submitted.

The warranty will not apply in cases of:

- Normal wear and tear
- Incorrect use, e.g. overloading of the appliance, use of non-approved accessories
- Use of force, damage caused by external influences
- Damage caused by non-observance of the user manual, e.g. connection to an unsuitable mains supply or non-compliance with the installation instructions
- Partially or completely dismantled appliances.

7. Maintenance

WARNING:

Ensure the machine is disconnected from the power supply before carrying out any maintenance and/or cleaning of the machine.

- Regularly clean the vacuum filters to prolong the life of the machine. Cleaning of the vacuum filters can be achieved by tapping/knocking the filter inside a garbage bin to release dust/debris from the filter and/or use compressed air to blow the dust/debris out. Always ensure you are wearing the correct personal protection equipment (PPE) when cleaning vacuum filters. Also always consider your surroundings and other persons within your working area when cleaning vacuum filters.
- Clean any dust/debris from around the vacuum filter basket and on the underside of the motor head unit on a regular basis to prevent any dust/debris getting sucked into the vacuum motors.
- Immediately replace any damaged vacuum filters.
- Never attempt to lubricate any motor components.

8. Specification

Model KV80-3 / KV100-3

Power 3600W

Cooling System Recycle

Vacuum Degree 20Kpa

Capacity 80L / 100L

Tank Diameter 420mm

Function Wet / Dry

Voltage 220-240V

Cable Length 8m

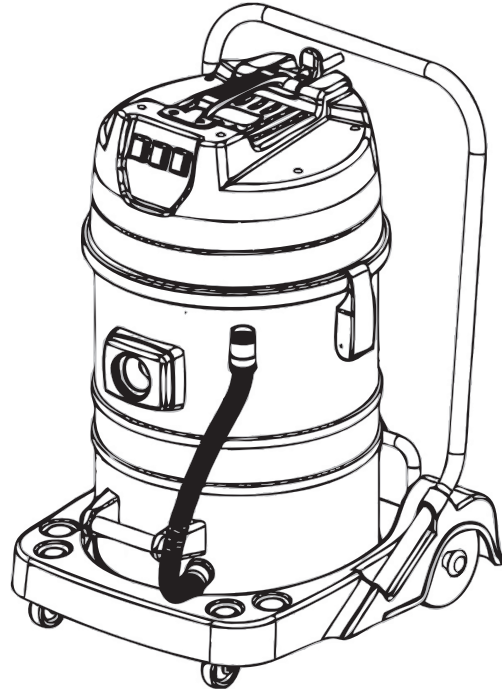

Accessories Included

1. Suction Hose
2. Inlet Connector
3. Tube Connector
4. Metal Tube
5. Dry Floor Nozzle
6. Wet Floor Nozzle
7. Crevice Nozzle
8. Dust Brush

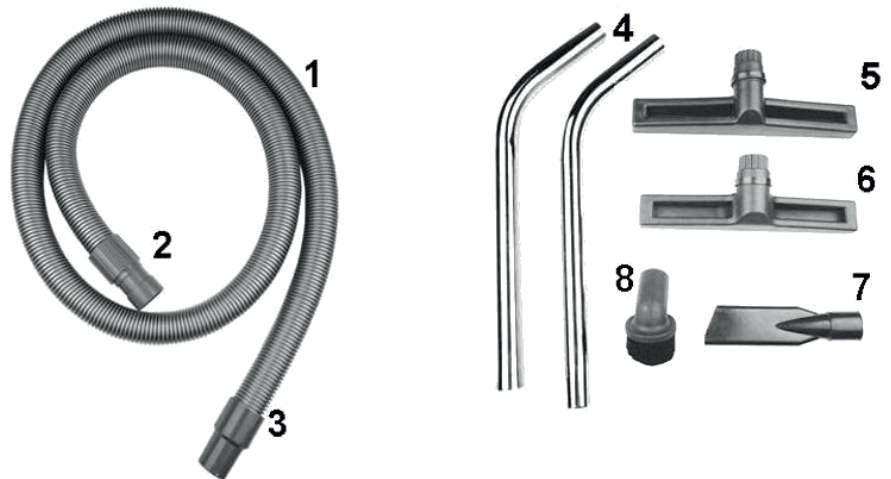

9. Parts List

1. Carry Handle
2. Power Cable
3. Top Cover
4. Wire Fixing Plate
5. Middle Cover
6. Motor Seal
7. Middle Cover Gasket
8. Air Outlet Sponge
9. Upper Gasket
10. Motor
11. Lower Gasket
12. Air Inlet Blocking Board
13. Motor Base
14. Barrel Cover
15. Rubber Seal
16. Filter
17. Support Basket
18. Tank
19. Tank Lock
20. Trolley Handle
21. Clip
22. Turnover Part
23. Turnover Shelf
24. Turnover Support Shelf
25. Axle Press-cover
26. Axle
27. Axle Press-bottom
28. Bung
29. Rubber Wheel
30. Castor Wheel
31. Trolley Base
32. Rubber Gasket
33. Drain Hose Nut
34. Rubber Gasket
35. Drain Hose
36. Drain Connection Ring
37. Drain Outlet Plug
38. Drain Hose Clip
39. Vacuum Hose
40. Stainless Steel Handle
41. Handle Connector
42. Vacuum Hose Connector
43. Inlet Connector
44. Dust Brush
45. Crevice Tool
46. Float Basket
47. Float Valve
48. Wet Floor Tool
49. Dry Floor Tool
50. Stainless Steel Tubes
51. Terminal
52. Capacitor
53. Switch

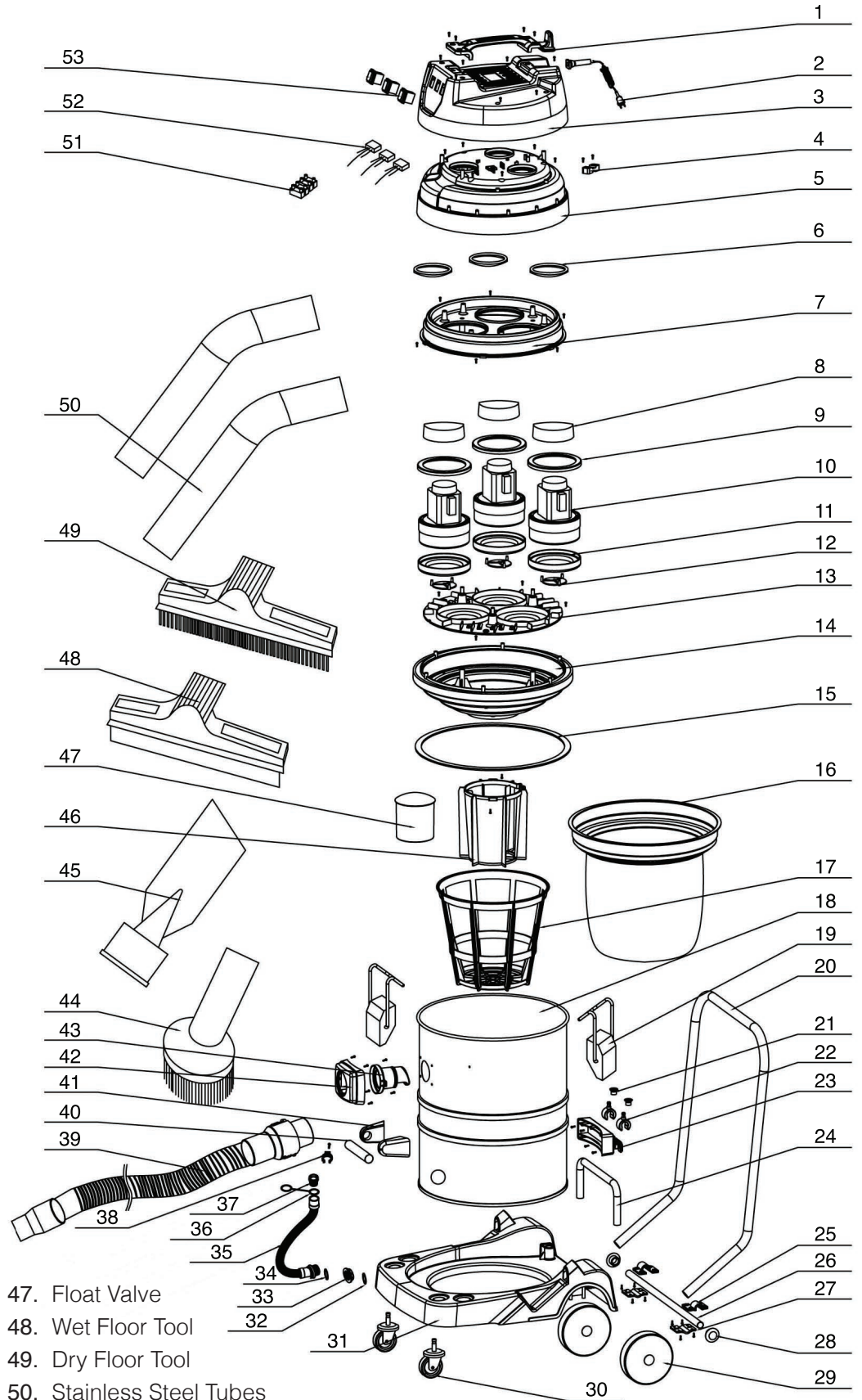

10. Troubleshooting

PROBLEM	CAUSES	SOLUTIONS
The vacuum cleaner fails to start	Power cord is disconnected	Check the electric power supply line is connected to your wall socket correctly
	Vacuum is not switched ON	Check that the vacuum is turned on. To turn on the vacuum press any of the on/off switches to the on position
	Electrical Fault	Contact an authorised service centre
The vacuum cleaner does not vacuum efficiently	Vacuum tank full	Empty the vacuum tank
	Dirty / clogged / full filter	Clean the cloth filter as described in the maintenance section. (Empty or replace filter bags if necessary)
	The vacuum safety float valve has intervened due to the tank being full of liquid	Empty the vacuum tank
	Check that the vacuum hose, floor tools and/or extension tubes are not blocked	Ensure that the hose is not blocked by removing the hose assembly and inserting a long object through the hose to clear any obstructions. Do not use excessive force to clear obstructions
	Vacuum motor head unit is not fitted correctly	Refit the vacuum motor head unit checking that it sits well onto the vacuum tank. Secure it in place with the tank locks
Substantial increase in motor revolutions and decrease in suction	Vacuum hose blocked	Ensure that the hose is not blocked by removing the hose assembly and inserting a long object through the hose to clear any obstructions. Do not use excessive force to clear obstructions
	The vacuum safety float valve blocks the vacuum caused by: A. Tank is full of liquid B. Vacuum has overturned	A. Turn of the vacuum and empty the tank B. Upright the vacuum and turn it off for approx. 3-5 seconds