

Standard 8 Foot Picnic Table

For Fastener Pack
(FP-SPT8-CU-03)

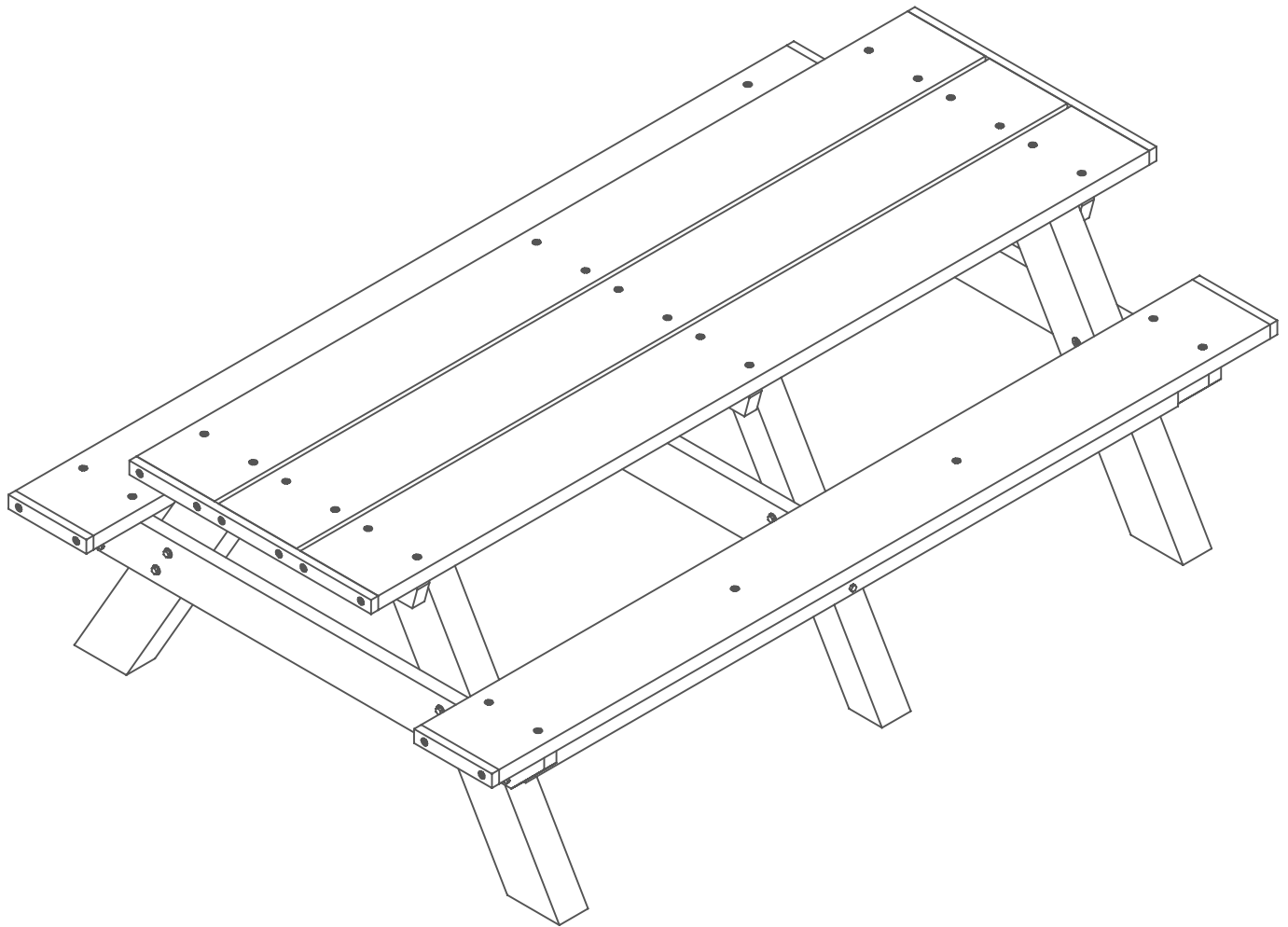

Congratulations ! !

You have purchased the finest recycled plastic
picnic table available. Enjoy ! ! !

Before assembly, please check to make sure all components are included.

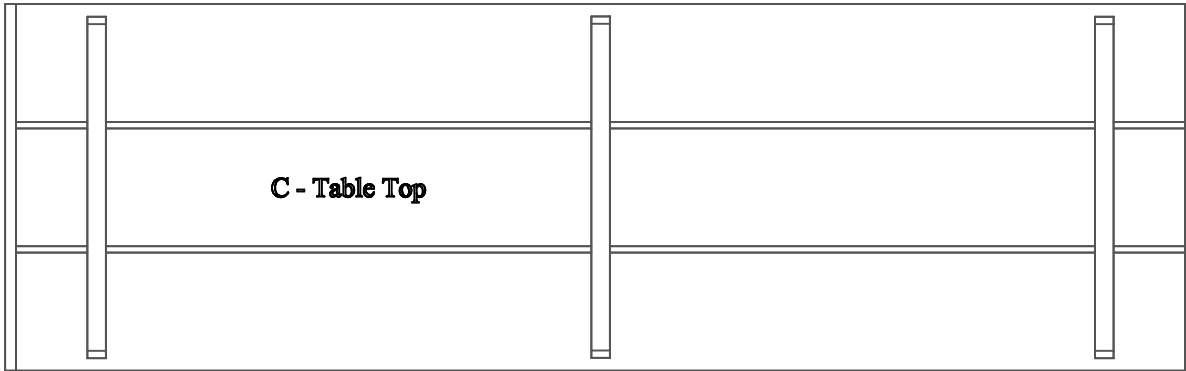

(1) - One Table Top
STSA-SPT8-A-03

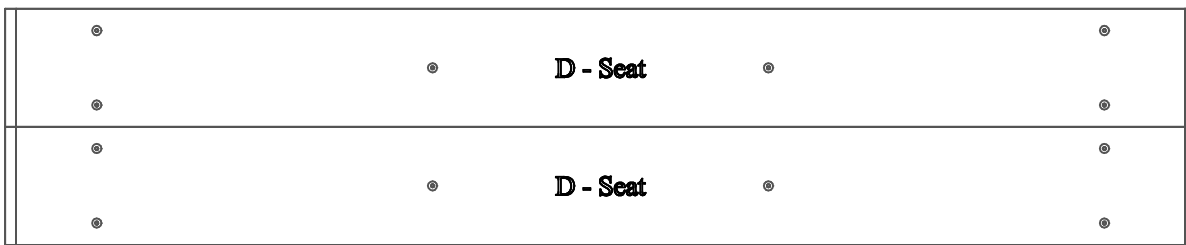

(2) - Two Seats
STSA-SPT8-B-02

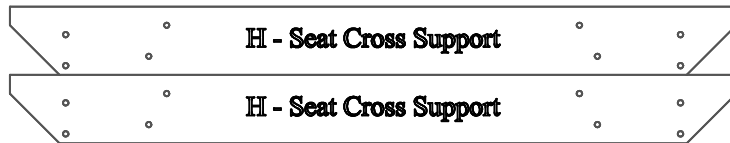

(2) - Two Seat Cross Supports
STP-S8-C-02



(2) - Two Under Seat Supports
STP-S8-D-01



(1) - One Center Support
STP-DS8-D-02



(1) - One Left Small Leg
STP-DS8-A-02



(1) - One Right Small Leg
STP-DS8-B-02



(1) - One Fastener Pack
FP-SPT8-CU-03

FP - Fastener Pack



(2) - Two Left Large Legs
STP-DS-A-02



(2) - Two Right Large Legs
STP-DS-B-02



Before assembly, please check to make sure all fasteners are included.

24 - 3/8" x 5" Hex Head Bolt

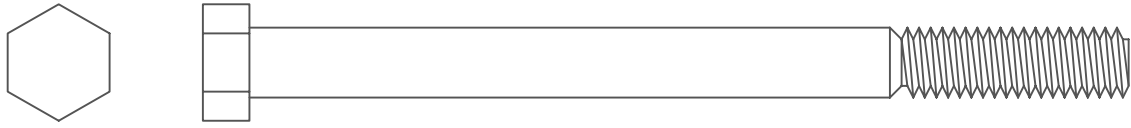

12 - 3/8" x 3" Hex Head Lag Bolt

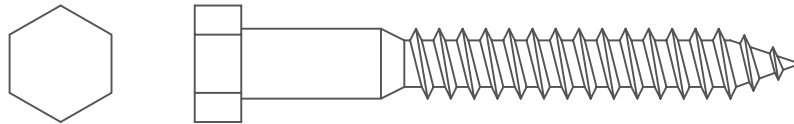

60 - 3/8" Flat Washer

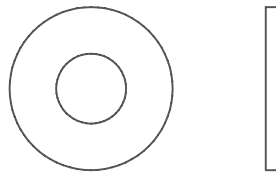

24 - 3/8" Nylon Lock Nut

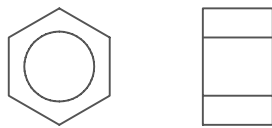

12 - #12 x 3" Phillips Head Flat Screw

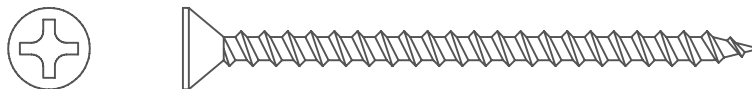

Also needed for this assembly will be the following materials:

1 - #3 Phillips Drive Bit

2 - 9/16" Socket Wrench

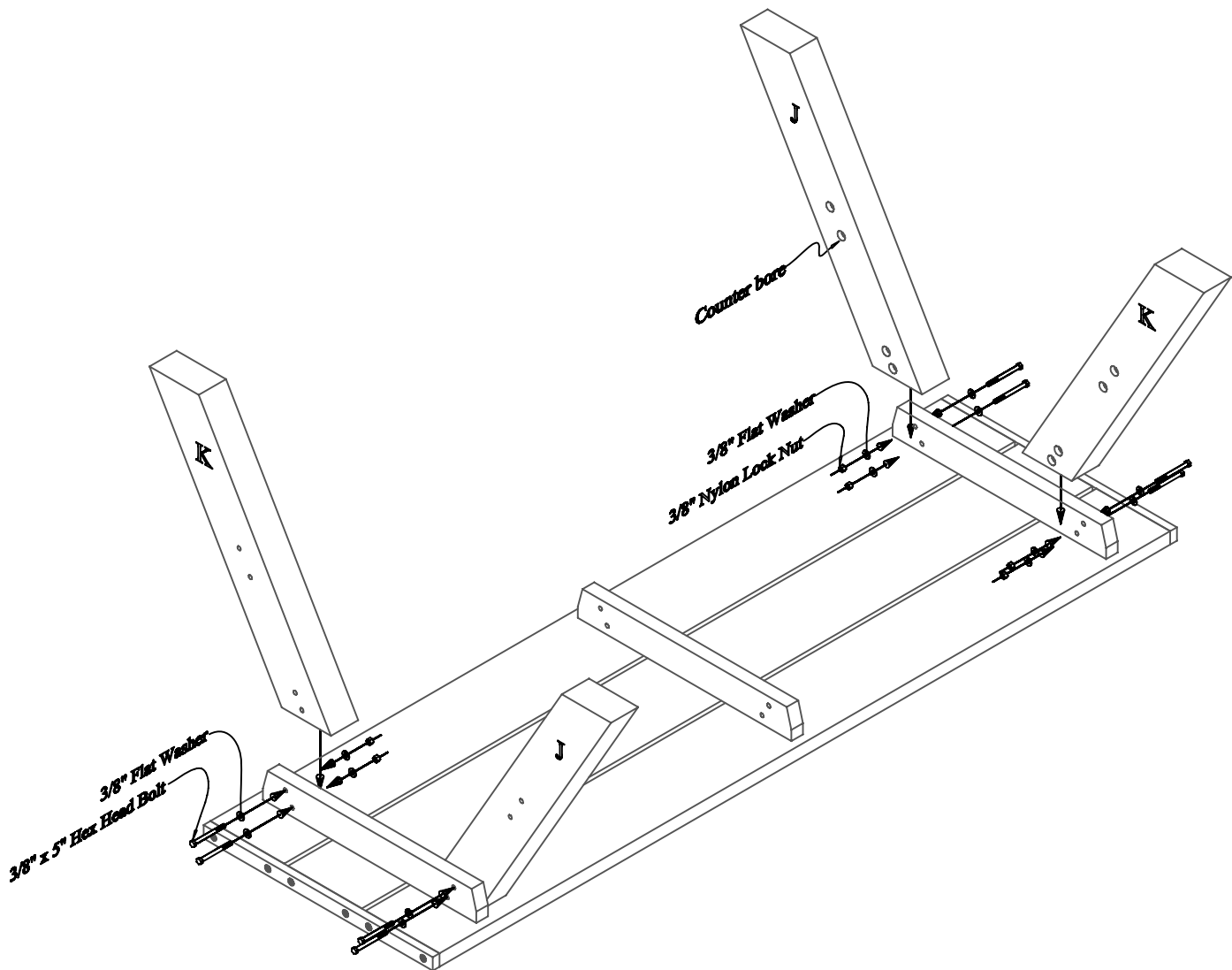

Step #1:

While the table top is upside-down, fasten the large legs to the left and right top supports being sure that the counter bores are pointing toward the center of the table as shown above. Use (1) One 3/8" x 5" Hex Head Bolt and (1) 3/8" Flat Washer along with, (1) One 3/8" Flat Washer and (1) One 3/8" Nylon Lock Nut per hole to secure.

Note: Do not tighten bolts completely. This will be done in a later step.

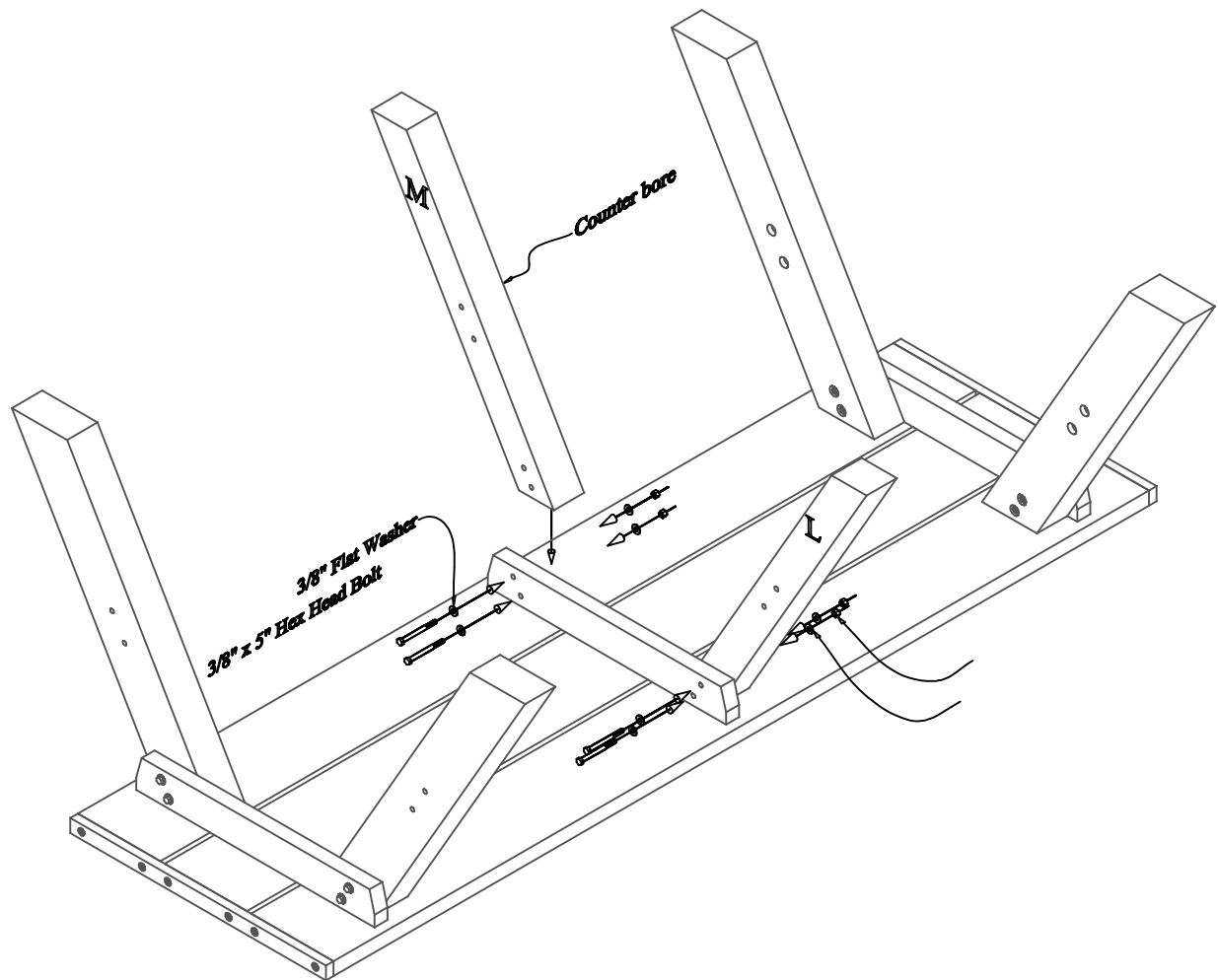

Step #2:

While the table top is upside-down, fasten the small legs to the center top support being sure that the counter bores are pointing away from the top support as shown above. Use (1) One 3/8" x 5" Hex Head Bolt and (1) One 3/8" Flat Washer along with, (1) One 3/8" Flat Washer and (1) One 3/8" Nylon Lock Nut per hole to secure.

Note: Do not tighten bolts completely. This will be done in a later step.

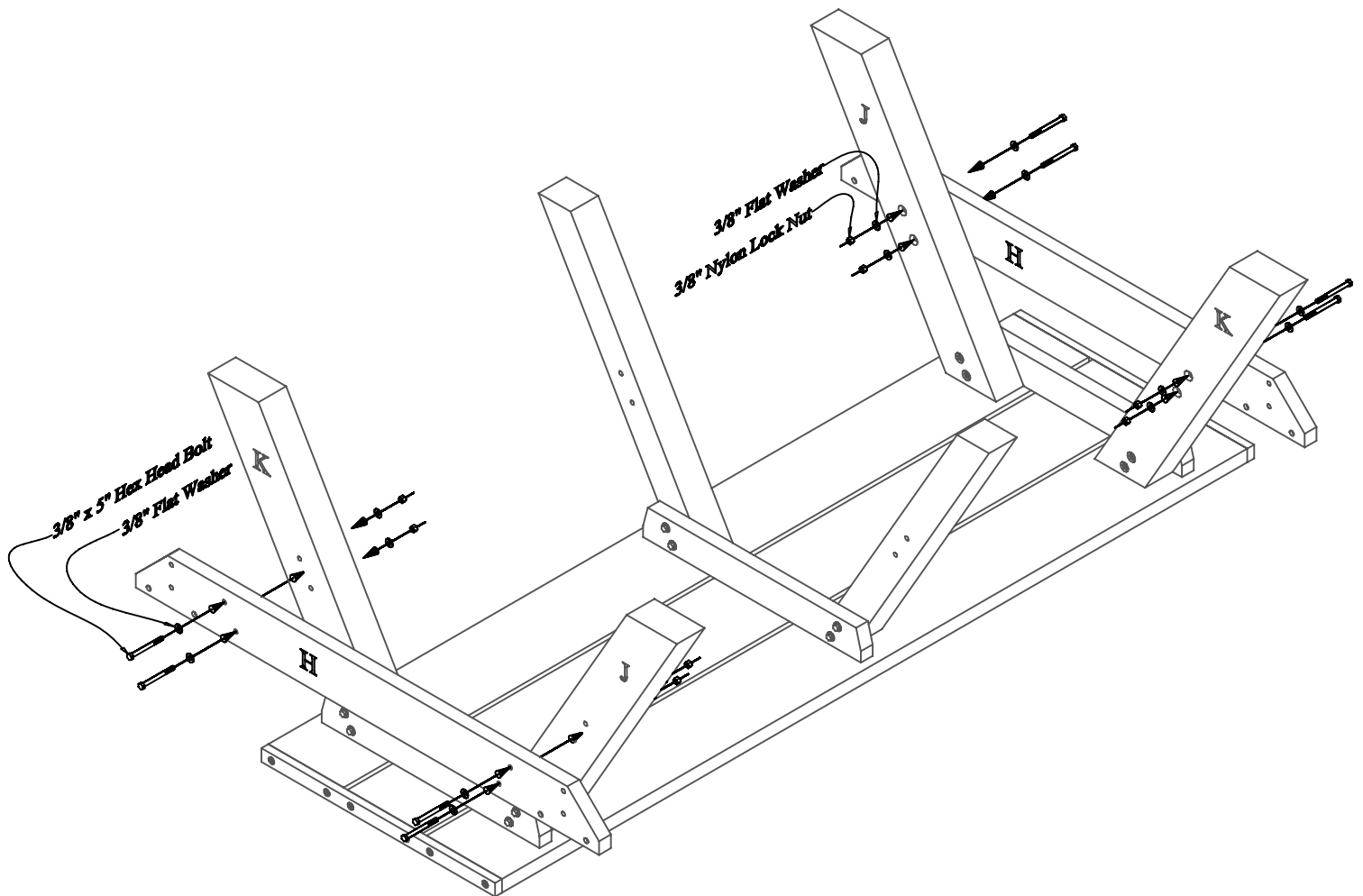

Step #3:

While the table is upside-down, fasten the seat cross supports to the large legs. Use (1) One 3/8" x 5" Hex Head Bolt and (1) One 3/8" Flat Washer along with (1) One 3/8" Flat Washer and (1) One 3/8" Nylon Lock Nut per hole to secure.

Note: Do not tighten bolts completely. This will be done in a later step.

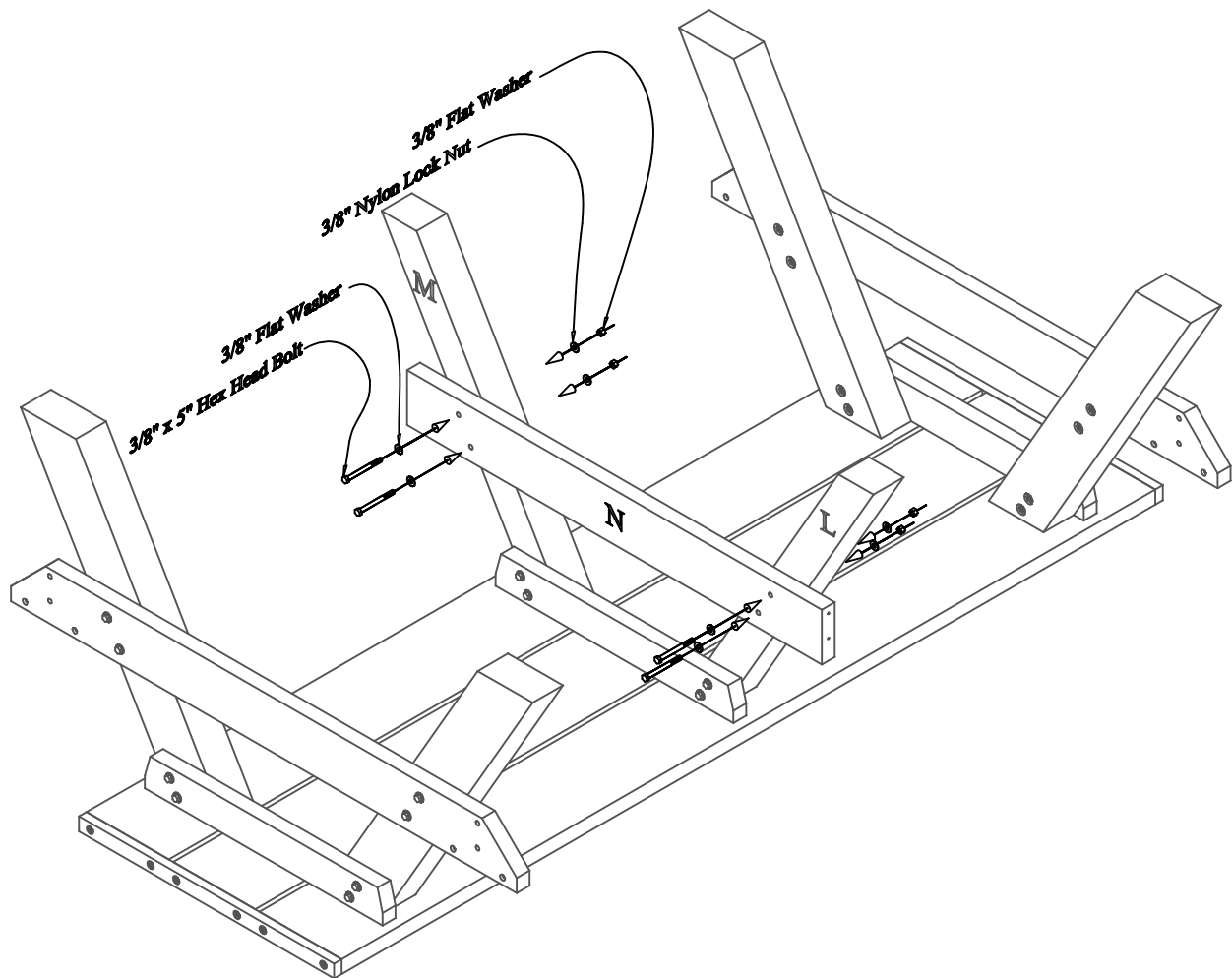

Step #4:

While the table is upside-down, fasten the center support to the small legs. Use (1) One 3/8" x 5" Hex Head Bolt and (1) One 3/8" Flat Washer along with (1) One 3/8" Flat Washer and (1) One 3/8" Nylon Lock Nut per hole to secure.

Note: Do not tighten bolts completely. This will be done in a later step.

Step #5:

While the table top is upside-down, fasten the under seat supports to the seat cross supports. Use (1) One 3/8" x 3" Hex Head Lag Bolt and (1) One 3 /8" Flat Washer per hole to secure.

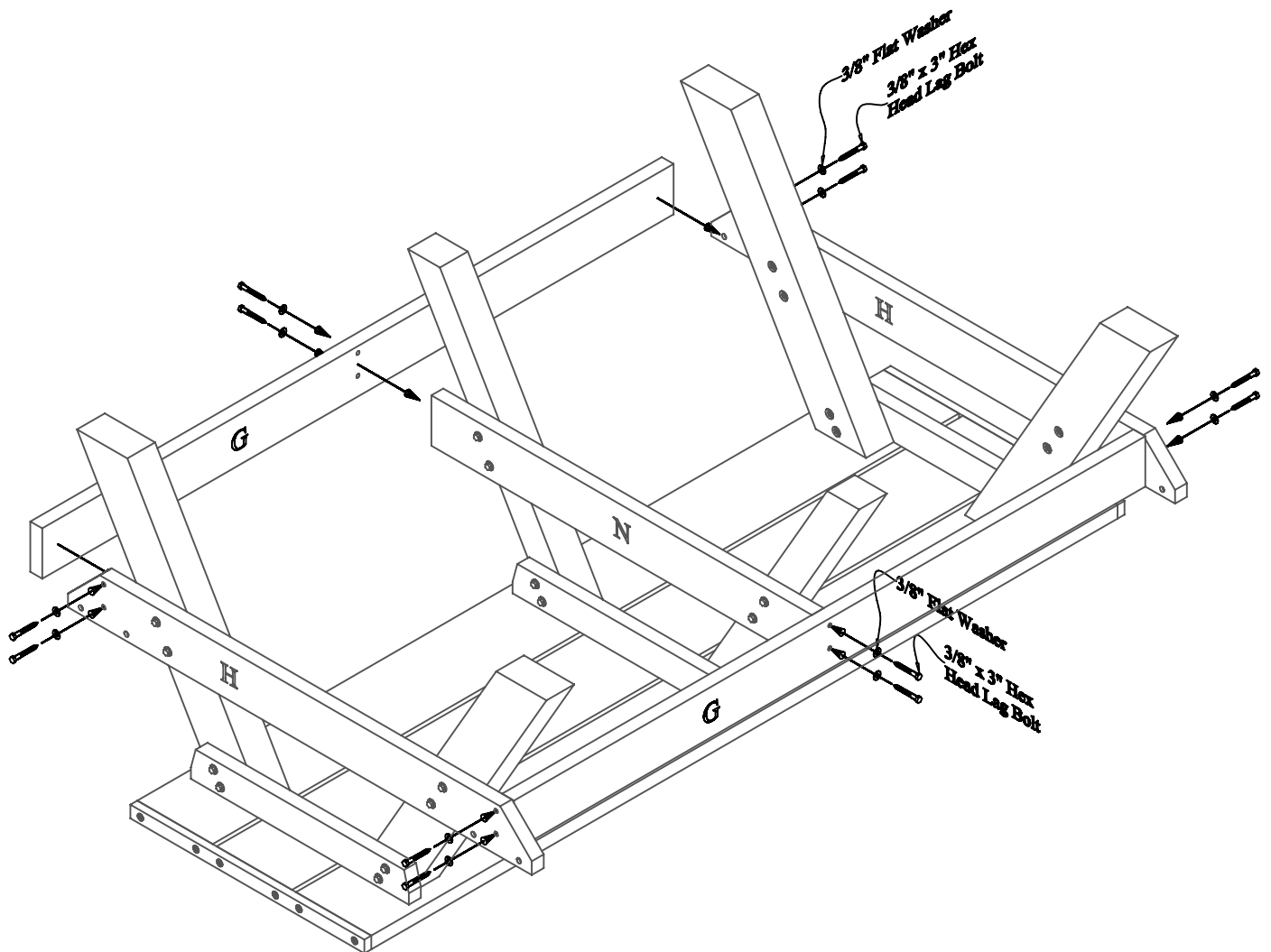

Step #6:

Secure the under seat supports completely by fastening to the center support. Use (1) One 3/8" x 3" Hex Head Lag Bolt and (1) One 3 /8" Flat Washer per hole to secure.

Note: Be sure to tighten all loose bolts after these steps are complete.

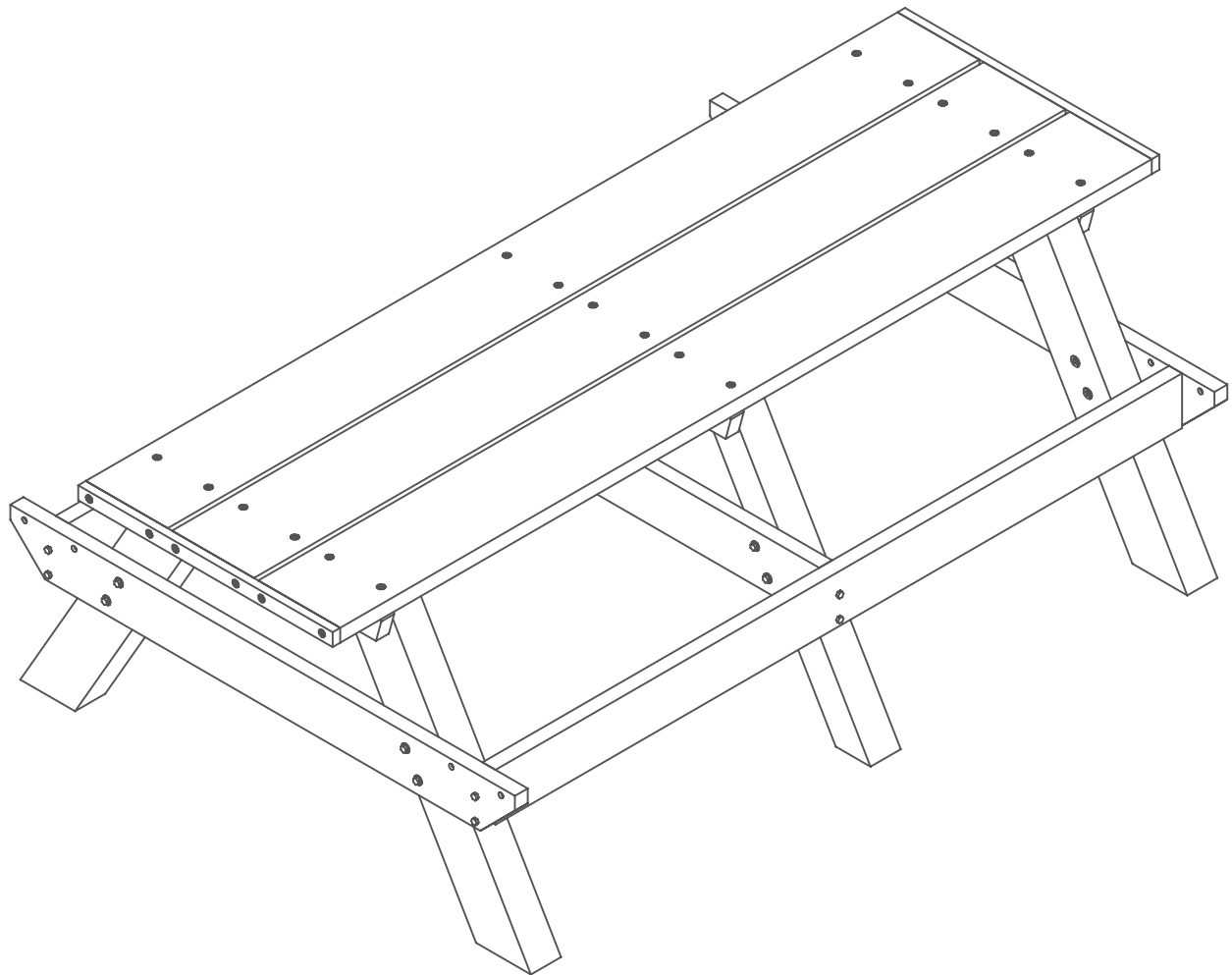

Step #7:

Flip the table upright onto the legs. Please take caution while flipping the table. At this point in assembly the table weighs approximately 320 Pounds.

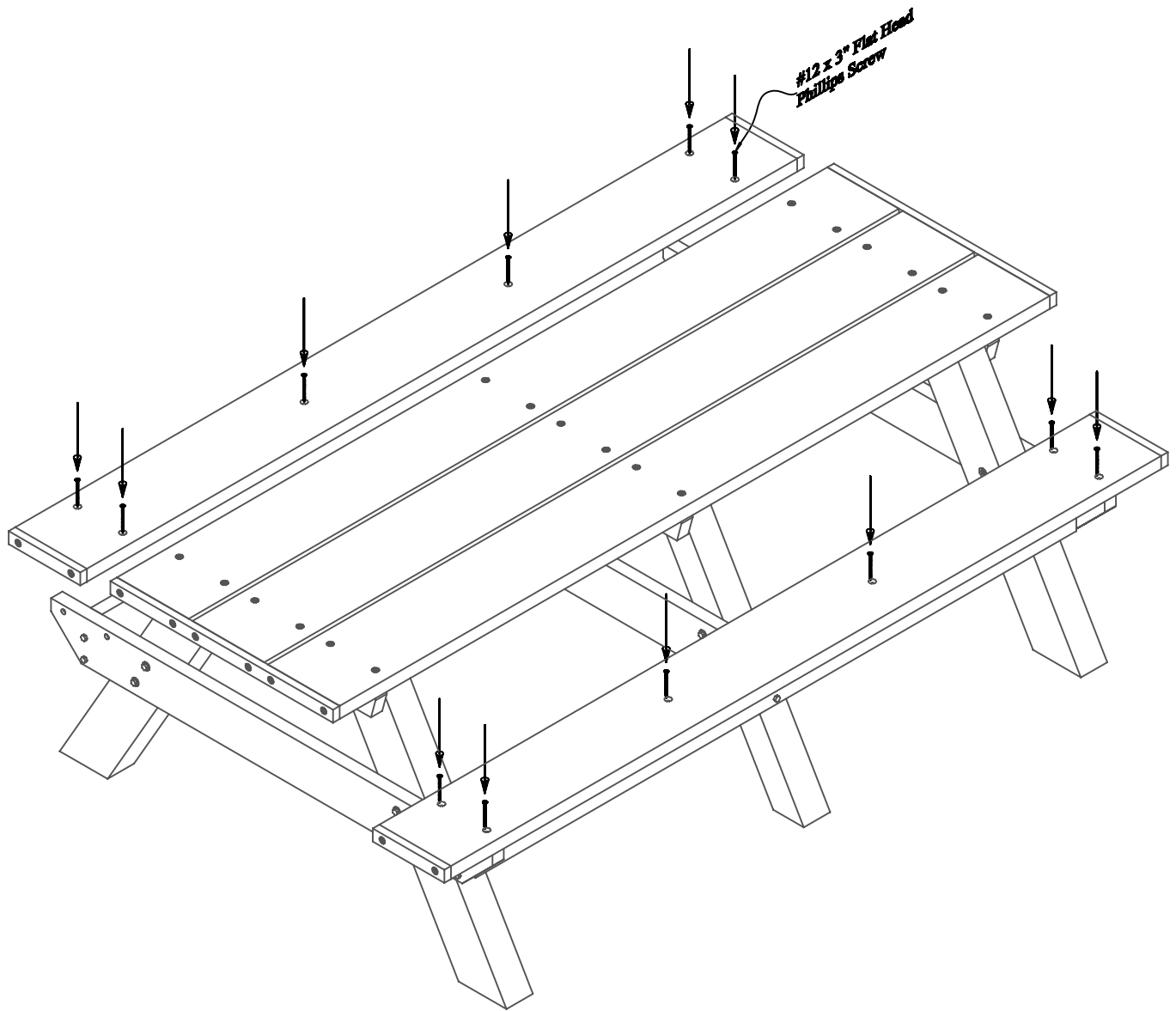

Step #8:

While the table is upright fasten the seats to the seat cross supports and under seat supports being sure to center all holes over boards. Use (1) One #12 x 3" Flat Head Phillips Screw per hole to secure.