

6 Foot Park Classic Park Bench w/ Arms

For Fastener Pack
(FP-PC6BA-CU-02)

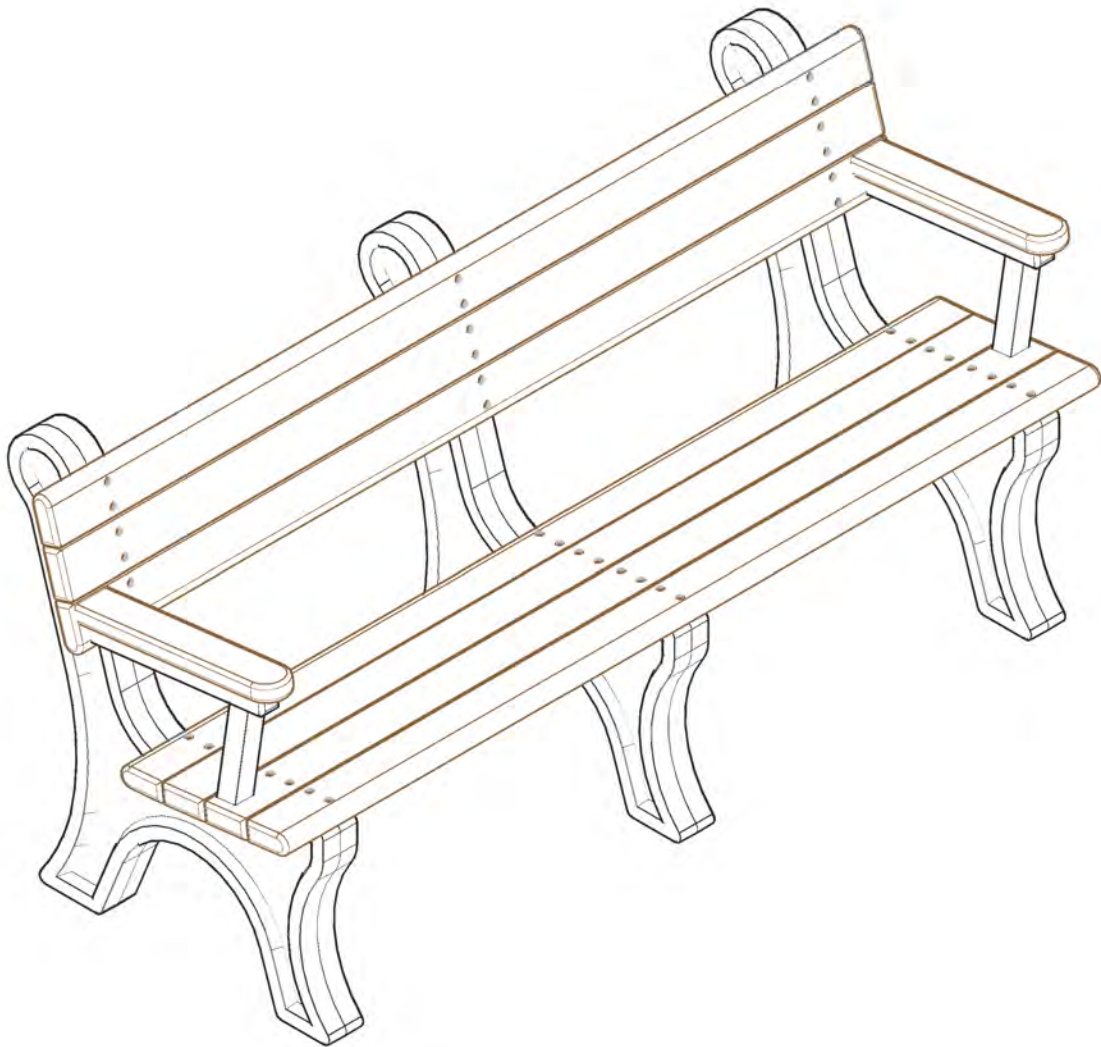

Congratulations !!

**You have just purchased the finest recycled plastic
park bench available. Enjoy !!!**

Before assembly, please make sure all components are included.



(1) - One Fastener Pack
FP-PC6BA-CU-02

FP - Fastener Pack

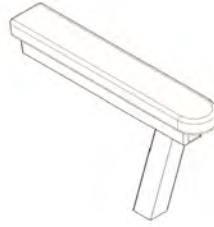

D - Bench Arm

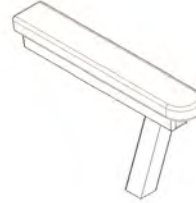

D - Bench Arm

(2) - Two Bench Arms
BSA-PCBA-A-00

B - Bench End

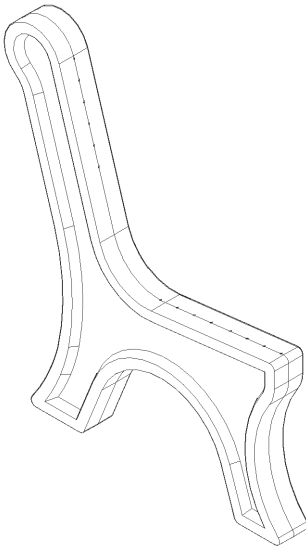

B - Bench End

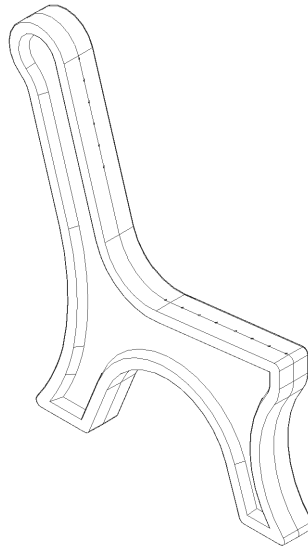

B - Bench End

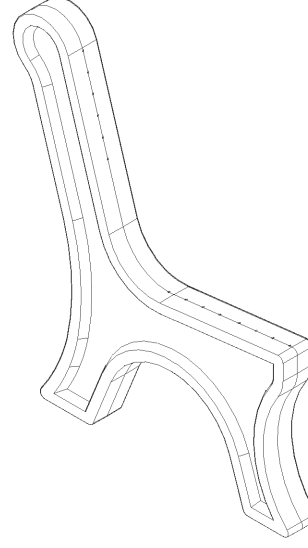

(3) - Three Bench Ends
PS-BTBE-P-02

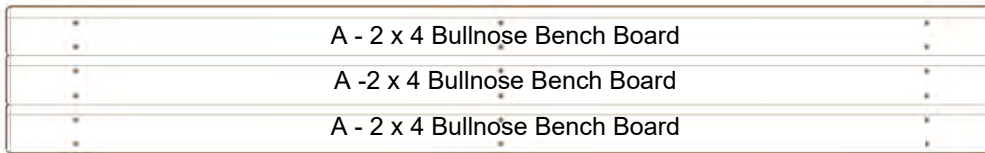

A - 2 x 4 Bullnose Bench Board

A - 2 x 4 Bullnose Bench Board

A - 2 x 4 Bullnose Bench Board

(3) - Three Bench Boards
BP-PC6B-A-02

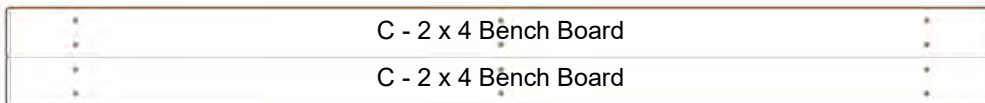

C - 2 x 4 Bench Board

C - 2 x 4 Bench Board

(2) - Two Bench Boards
BP-DB6B-A-03

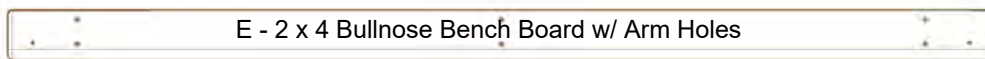

E - 2 x 4 Bullnose Bench Board w/ Arm Holes

(1) - One Bench Board
BP-PC6BA-A-02



F - 2 x 4 Bench Board w/ Arm Holes

(1) - One Bench Board
BP-DB6BA-A-03

FS-PC6BA-CAP-02

Before assembly, please make sure all fasteners are included.

46 - #12 x 3" Flat Head Phillips Screw



Also needed for this assembly will be the following materials:

1 - #3 Phillips Drive Bit

***IMPORTANT NOTICE*:**

- DO NOT OVER-TIGHTEN SCREWS.
- USE A DRILL WITH ADJUSTABLE TORQUE FOR BEST RESULTS.
- OVER-TIGHTENING WILL RESULT IN STRIPPING OUT THE PILOT HOLE, AND SCREW WILL "SINK" INTO THE PLASTIC WHICH MAY CAUSE A STRESS FRACTURE.

Fig #1:

In order to make the assembly of this Park Classic Bench easier while going through the assembly process the board positions are numbered and will be referenced in later steps.

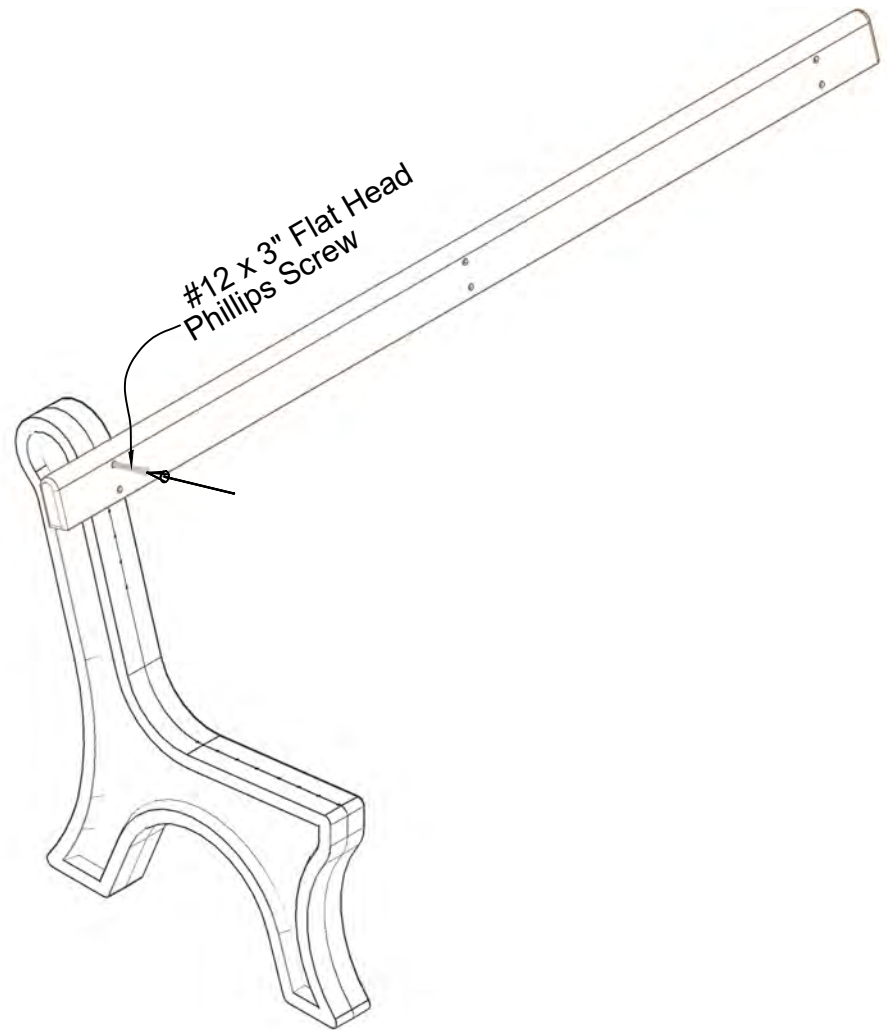
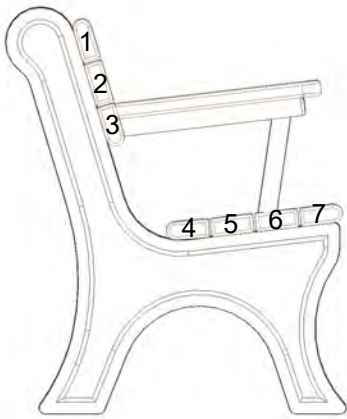

Step #1:

Stand (1) One bench end (Part B) upright and place (1) One bench board (Part A) on position 1 being sure to place bullnose facing top of bench align the pre-drilled holes to the pilot holes in the bench end. After the holes are properly aligned, fasten with (1) One #12 x 3" Flat Head Phillips Screw in the top pre-drilled hole.

Note: Do not tighten screw completely. This will be done in a later step.

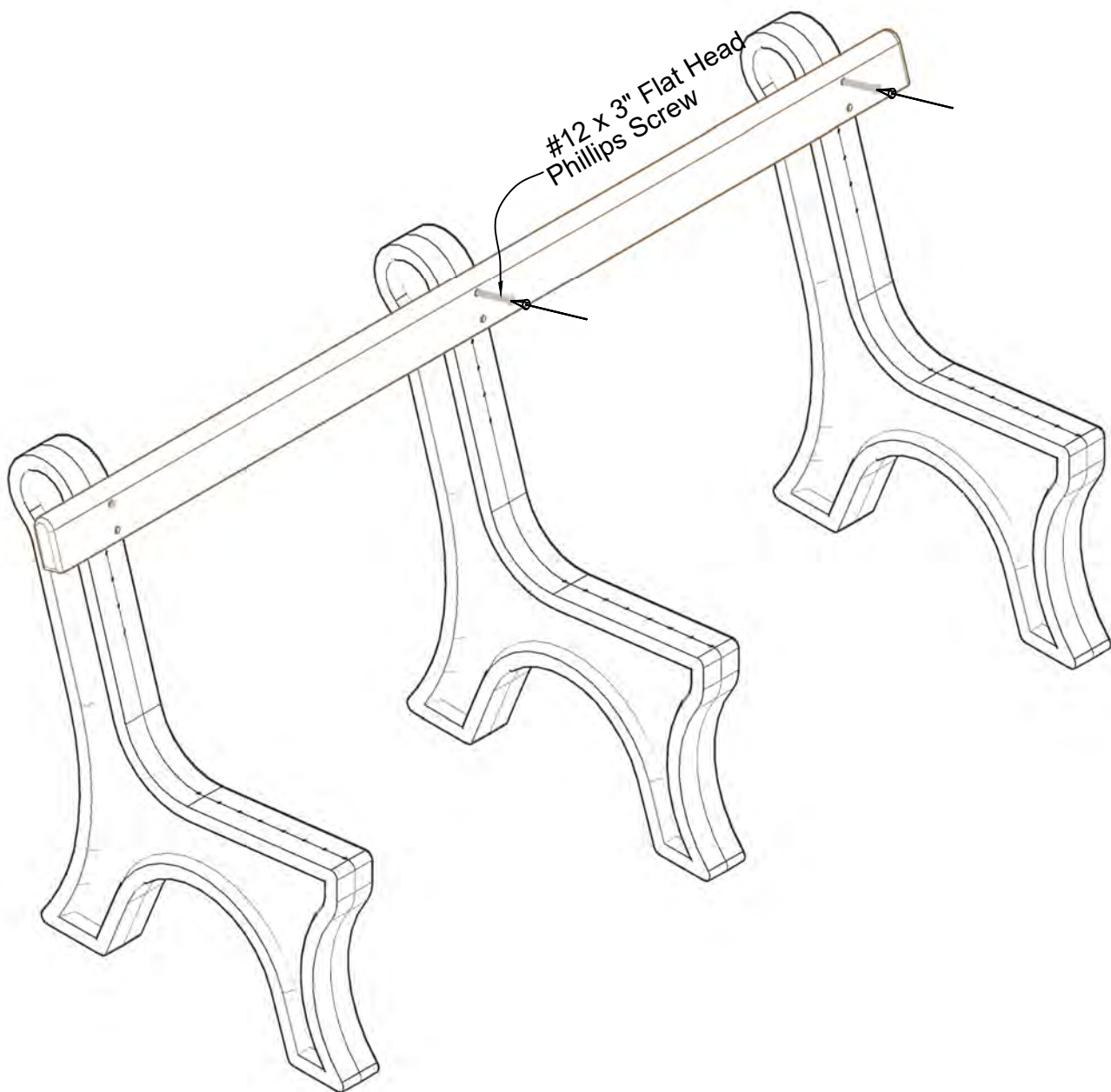

Step #2:

Stand the other bench end (Part B) upright and place the bench board (Part A) already attached to the first bench end, on position 1 being sure to align the pre-drilled holes to the pilot holes in the bench end. After the holes are properly aligned, fasten with (1) One #12 x 3" Flat Head Phillips Screw in the top pre-drilled hole.

Note: Do not tighten screws completely. This will be done in a later step.

Step #3:

Align bottom pre-drilled holes to the pilot holes in the bench end (Part B). After the holes are properly aligned, fasten with (1) One #12 x 3" Flat Head Phillips Screw per hole.

Note: Be sure to tighten screws completely after this step.

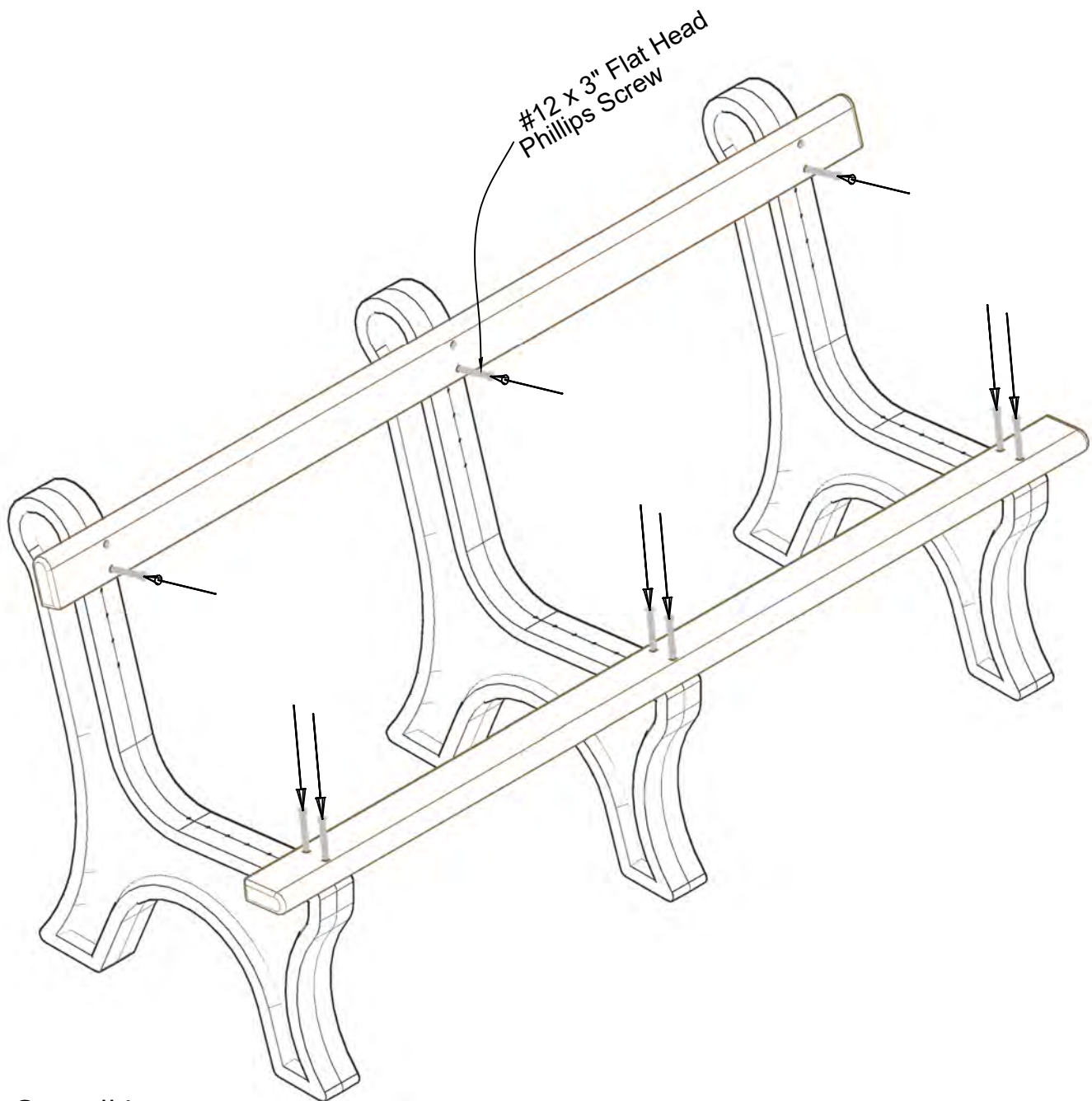

Step #4:

Place a bench board (Part A) on position 7 with bullnose facing front of bench. Repeat Steps 1 - 3 to attach. Use (1) One #12 x 3" Flat Head Phillips Screw per hole to fasten.

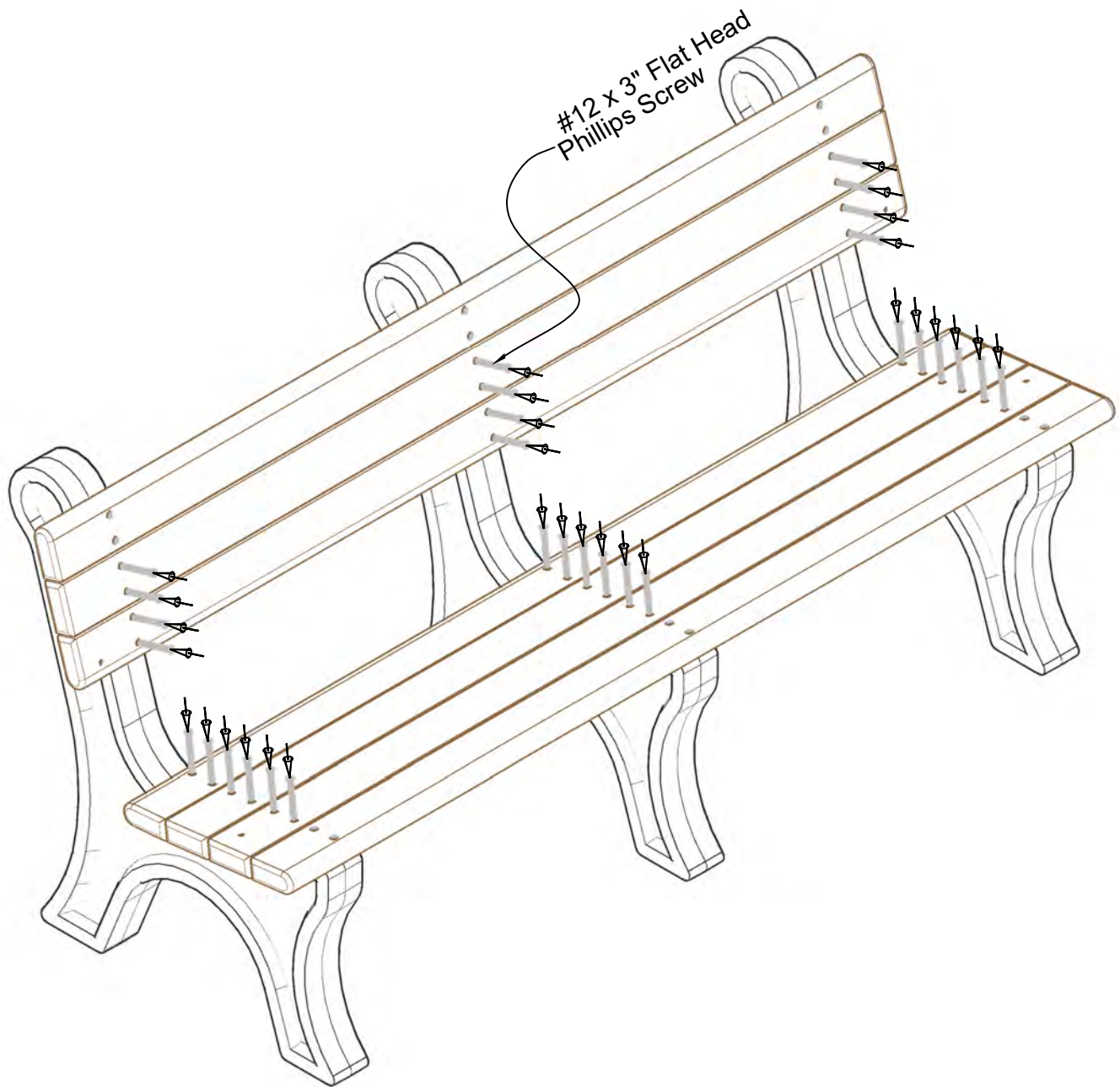

Step #5:

Repeat Steps 1 - 3 to attach bench board (Part A) on position 4 with bullnose facing back of bench. Attach bench board (Part C) on positions 2 & 5. Attach bullnose bench board w/ arm hole (Part E) on position 3 with bullnose facing down and bench board w/ arm hole (Part F) on position 6 with arm holes towards back of bench. Use (1) One #12 x 3" Flat Head Phillips Screw per hole to fasten.

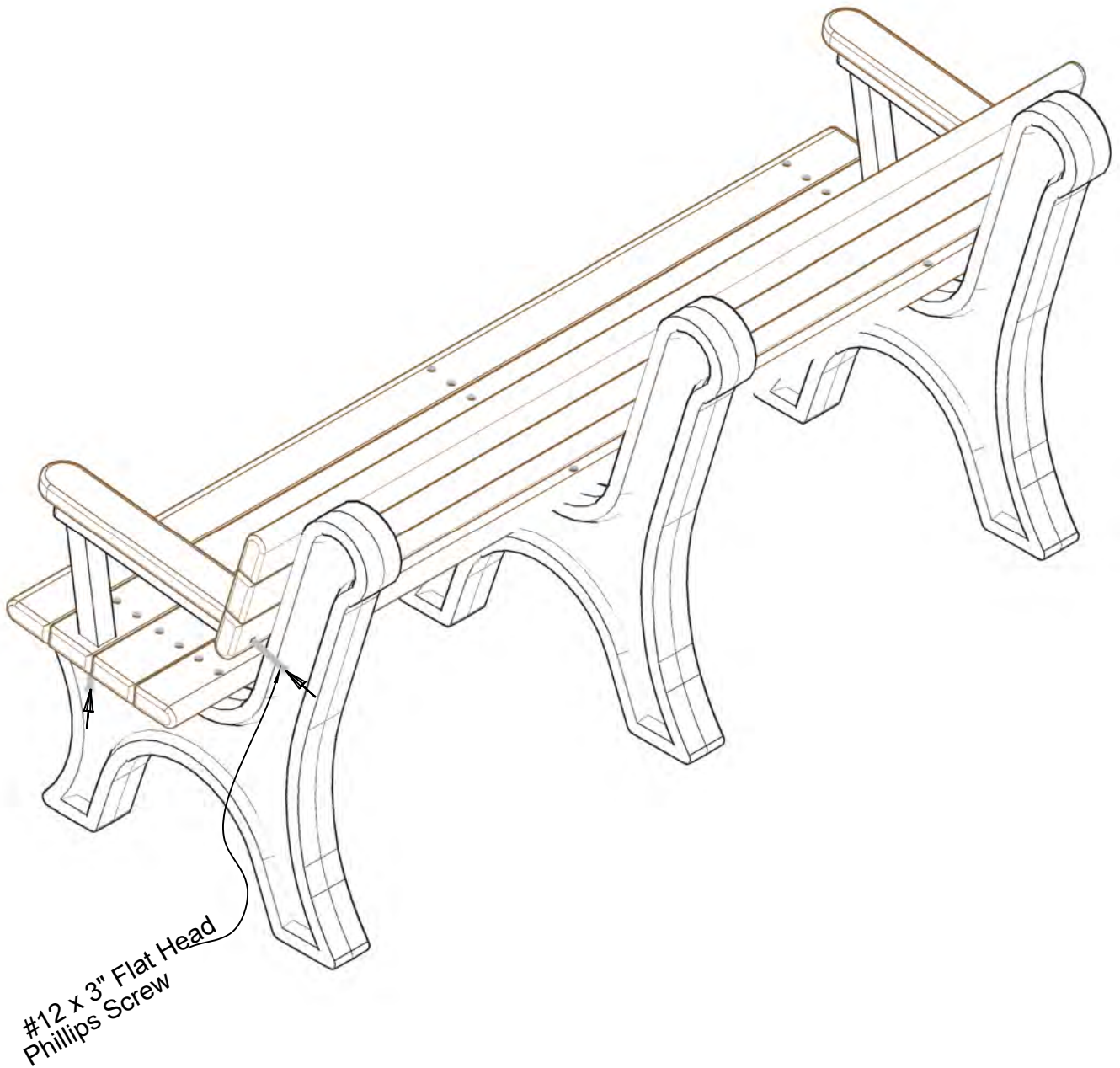

Step #6:

Position the bench arms (Part D) as shown above. Align the pilot holes to the pre-drilled holes in the bench board w/ arm holes. After the holes are properly aligned, fasten with (1) One #12 x 3" Flat Head Phillips Screw per hole.

DEAR VALUED CUSTOMER,

THANK YOU FOR PURCHASING THIS PRODUCT. THIS PRODUCT IS MANUFACTURED USING RECYCLED MATERIALS AND MAY HAVE SLIGHT COLOR VARIATIONS, OCCASIONAL SPECKS OF COLOR OR IRREGULAR SURFACE PATTERNS. THESE ARE NORMAL CONDITIONS OF RECYCLED PLASTICS AND MAKE EACH PIECE OF FURNITURE UNIQUE. THESE CHARACTERISTICS DO NOT AFFECT THE STRENGTH, QUALITY OR PERFORMANCE OF THE PRODUCT.

THANK YOU AGAIN FOR PURCHASING THIS PRODUCT AND HELPING OUR ENVIRONMENT.