

# 4 Foot Landmark Park Bench

For Fastener Pack  
(FP-LB4B-CU-02)

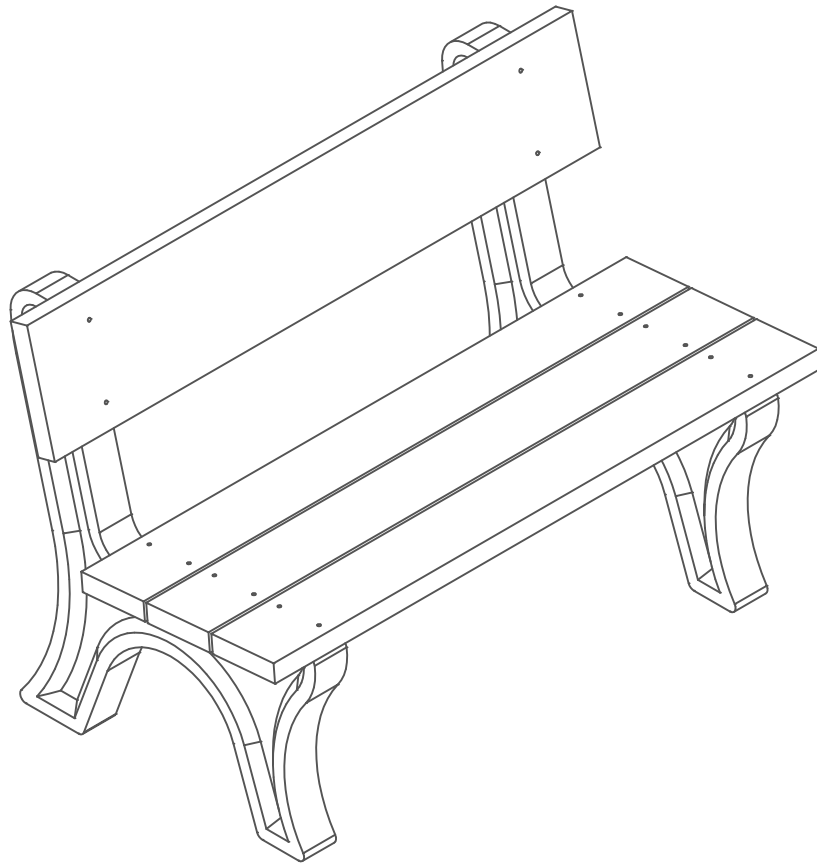

Congratulations ! !

You have just purchased the finest recycled plastic  
park bench available. Enjoy ! ! !

Before assembly, please make sure all components are included.

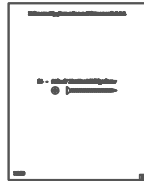

(1) - One Fastener Pack  
FP-LB4B-CU-02

FP - Fastener Pack

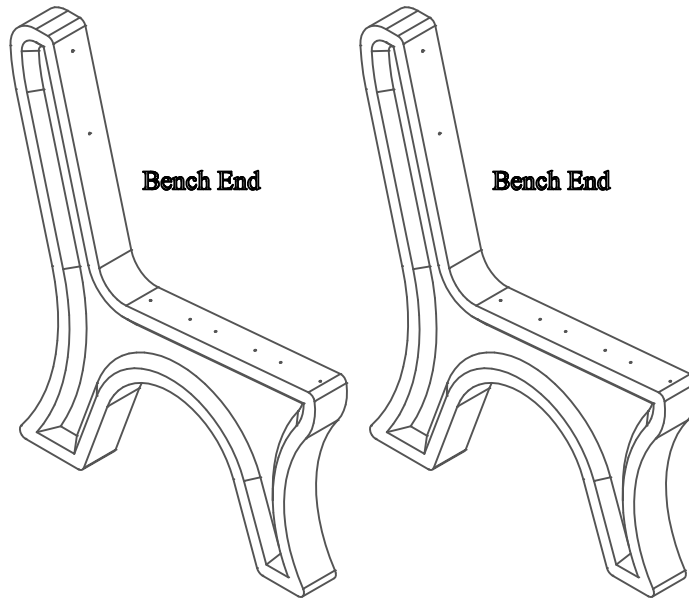

(2) - Two Bench Ends  
PS-SBBE-L-02



(1) - One Back Bench Board  
BP-LB4B-A-01

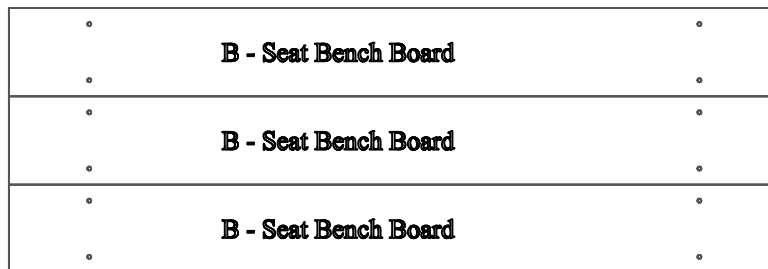

(3) - Three Seat Bench Boards  
BP-TB4B-A-02

Before assembly, please make sure all fasteners are included.

16 - #12 x 3" Flat Head Phillips Screw



Also needed for this assembly will be the following materials:

1 - #3 Phillips Drive Bit

**\*IMPORTANT NOTICE\*:**

- \* DO NOT OVER-TIGHTEN SCREWS.
- \* USE A DRILL WITH ADJUSTABLE TORQUE FOR BEST RESULTS.
- \* OVER-TIGHTENING WILL RESULT IN STRIPPING OUT THE PILOT HOLE, AND SCREW WILL "SINK" INTO THE PLASTIC WHICH MAY CAUSE A STRESS FRACTURE.

**Fig #1:**

In order to make the assembly of this Landmark Bench easier while going through the assembly process the board positions are numbered and will be referenced in later steps.

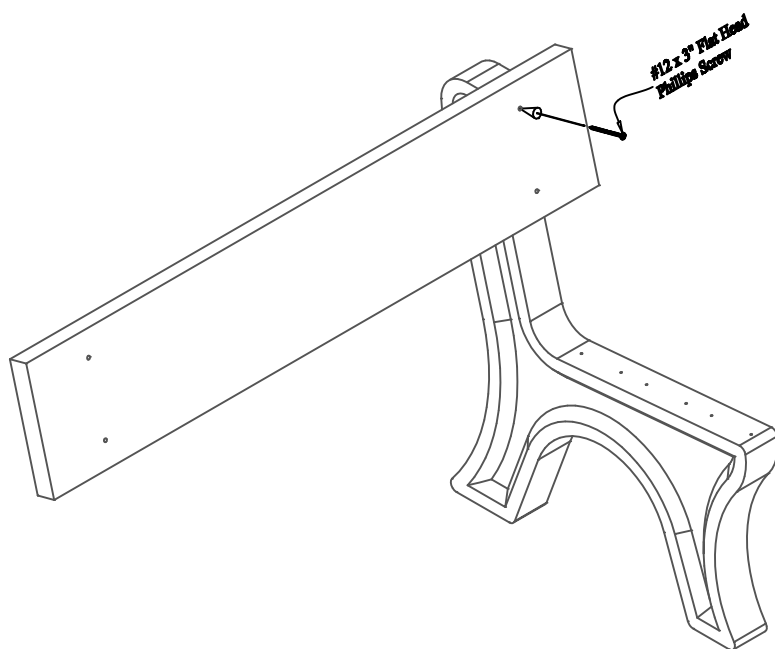
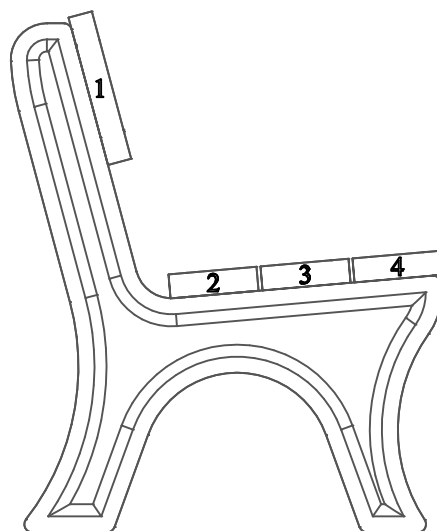

**Step #1:**

Stand (1) One bench end upright and place (1) One back bench board on position 1 being sure to align the pre-drilled holes to the pilot holes in the bench end. After the holes are properly aligned, fasten with (1) One #12 x 3" Flat Head Phillips Screw in the top pre-drilled hole of the back bench board.

Note: Do not tighten screw completely. This will be done in a later step.

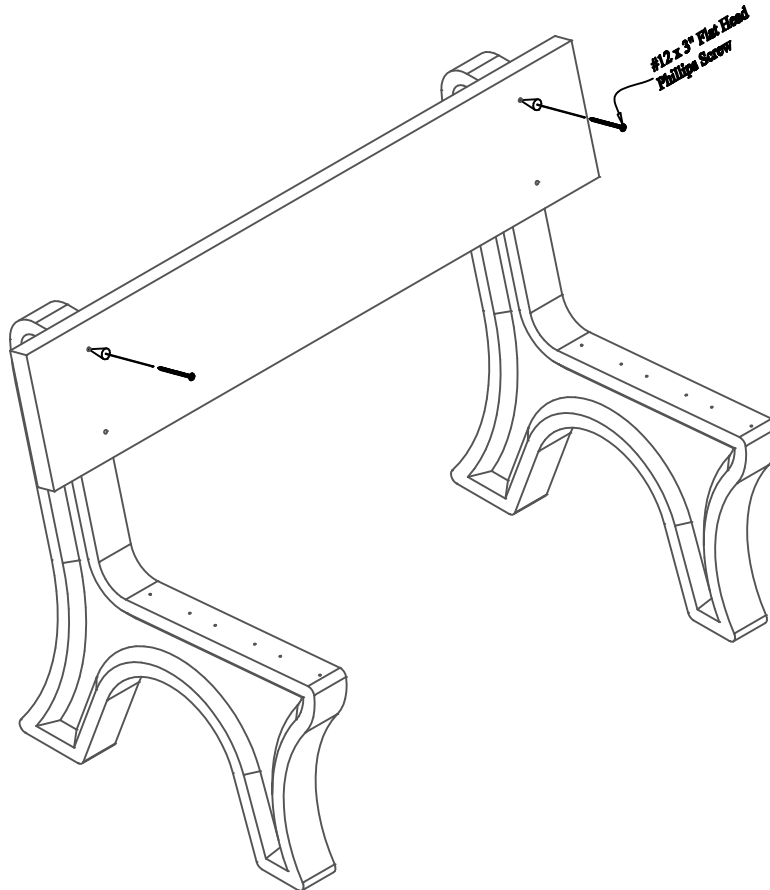

### Step #2:

Stand the other bench end upright and place the back bench board already attached to the first bench end, on position 1 being sure to align the pre-drilled holes with the pilot holes in the bench end. After the holes are properly aligned, fasten with (1) One #12 x 3" Flat Head Phillips Screw in the top pre-drilled hole of the back bench board.

Note: Do not tighten screws completely. This will be done in a later step.

### Step #3:

Align the bottom pre-drilled holes on the back bench board to the pilot holes on the bench end. After the holes are properly aligned, fasten with (1) One #12 x 3" Flat Head Phillips Screw per hole.

Note: Be sure to tighten screws completely after this step.

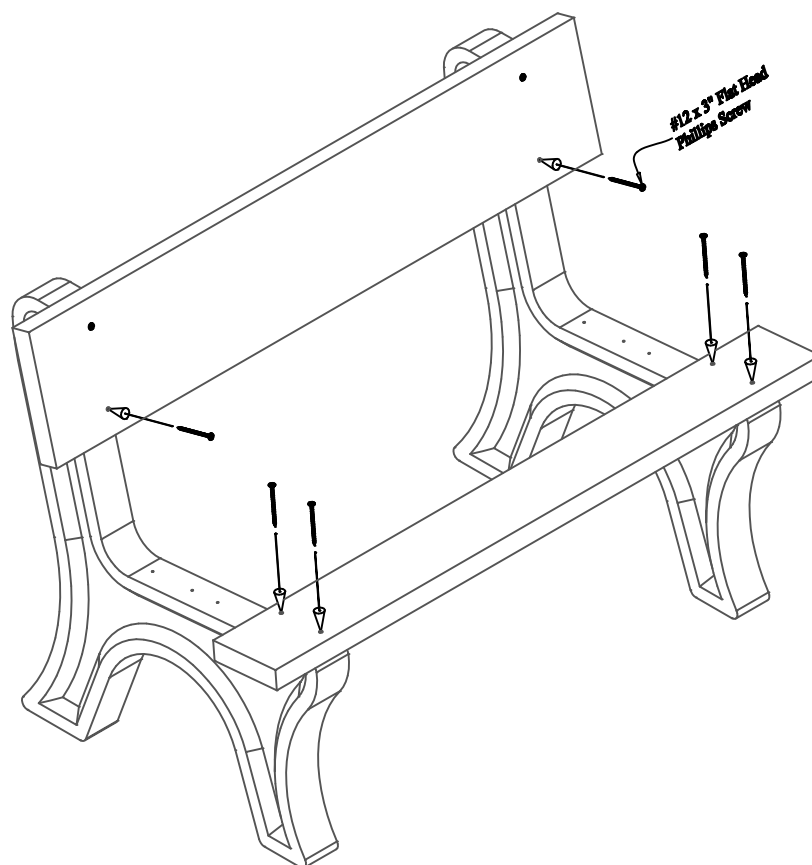

### Step #4:

Place (1) One seat bench board on position 4. Repeat Steps 1 - 3 to attach. Use (1) One #12 x 3" Flat Head Phillips Screw per hole to fasten.

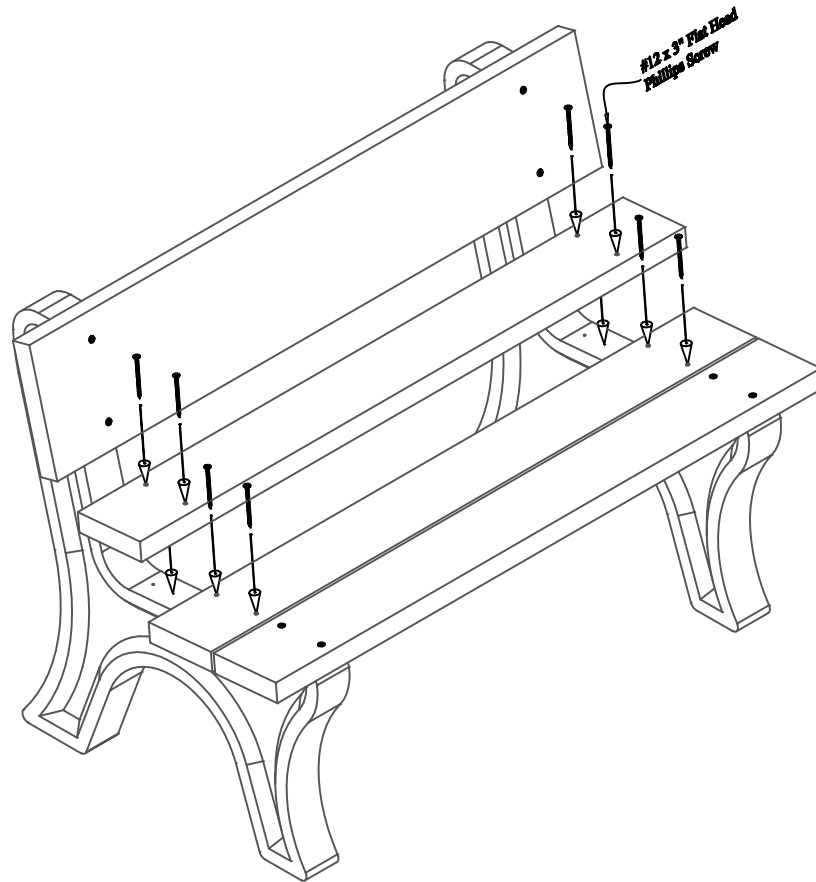

**Step #5:**

Repeat Steps 1 - 3 to attach seat bench boards on positions 2 & 3. Use (1) One #12 x 3" Flat Head Phillips Screw per hole to fasten.

DEAR VALUED CUSTOMER,

THANK YOU FOR PURCHASING THIS PRODUCT. THIS PRODUCT IS MANUFACTURED USING RECYCLED MATERIALS AND MAY HAVE SLIGHT COLOR VARIATIONS, OCCASIONAL SPECKS OF COLOR OR IRREGULAR SURFACE PATTERNS. THESE ARE NORMAL CONDITIONS OF RECYCLED PLASTICS AND MAKE EACH PIECE OF FURNITURE UNIQUE. THESE CHARACTERISTICS DO NOT AFFECT THE STRENGTH, QUALITY OR PERFORMANCE OF THE PRODUCT.

THANK YOU AGAIN FOR PURCHASING THIS PRODUCT AND HELPING OUR ENVIRONMENT.