

Build your very own race car using the energy stored in rubber bands!

Get started with the example build, then make your own unique design!

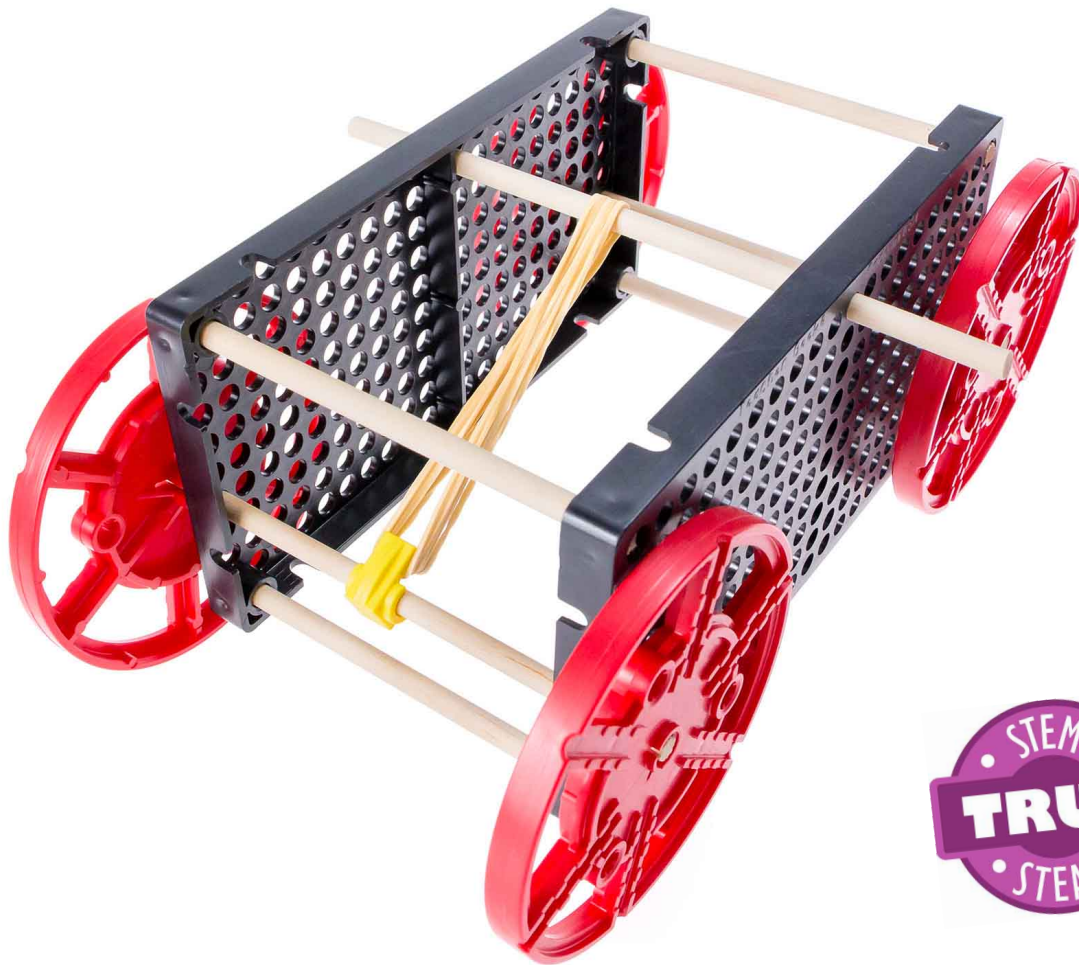

You Are Here

Choose how you would like to complete this activity.

Download documents & videos at teachergeek.com/rubberband

Go Guide

Start here! Build your example racer, evolve your design, and begin the Long Shot Challenge!

Optional Labs

-Ramp Roll Lab
-Energy Lab
-Atwood's Machine

Optional Challenges

-Sprint Challenge*
-Target Challenge*

*See Page 6

RACER SUPPLIES

TEACHERGEEK PARTS

These are the components you need to build one Rubber Band Racer, including some extra parts so you can experiment and create your own designs.

NAME	QTY	PICTURE
Strips 30 cm (12 in) SKU 1821-31	4	
Tire Rubber Bands SKU 1821-64	2	
Hole Plates SKU 1821-32	2	
Slide Stop 8 cm (3 in) SKU 1821-49	1	
Wheels SKU 1821-30	4	
Stop Clip SKU 1821-60	2	
Rubber Bands SKU 1823-41	10	
Screws 25 mm (1 in) SKU 1821-22	4	
Nuts #10 Hex SKU 1821-25	4	
Dowels various sizes SKU 1821-20	12	 <u>Dowel Sizes</u> 1x 15 cm (6") 4x 10 cm (4") 4x 13 cm (5") 3x 5 cm (2")

Have a Maker Cart?
Use Multi-Cutters to
cut your own dowels.



MATERIALS YOU SUPPLY

- **Scissors**
- **Glue or Super Glue**
(optional)
- **Recycling Bin Materials**
(optional)

Optional Tools



Modify materials to make even more creative designs with the **TeacherGeek / Maker Tool Set**
SKU 1823-84



Check out the [Build Video](#) scanning the QR Code or going to teachergeek.com/rubberband

GET READY TO ROLL

- 1 Wiggle four 10 cm (4 in) dowels into the corners of an upside-down hole plate.

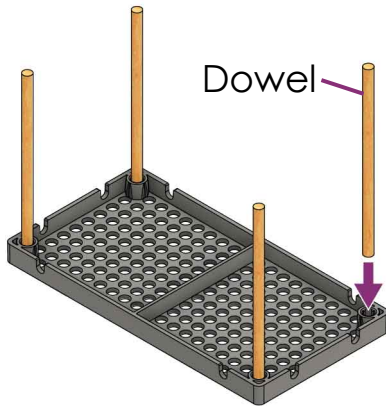

- 2 Tap or push another hole plate onto the dowels to finish your frame.

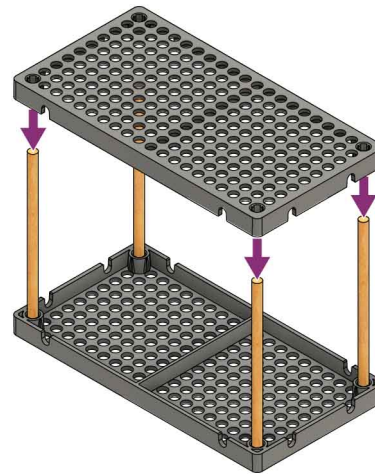

- 3 Wiggle two 13 cm (5 in) dowels into wheels so the boss (bump) faces up.

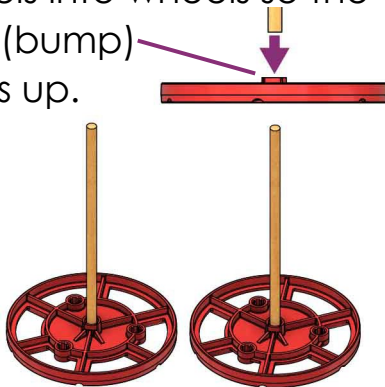

- 4 Slide the **axes** (dowels attached to wheels) through the frame, two holes from the bottom.

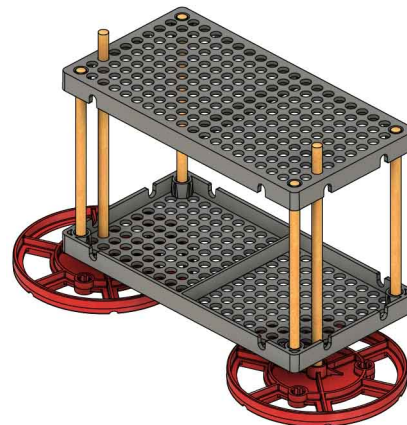

- 5 Push or tap wheels onto the other side of the axes.

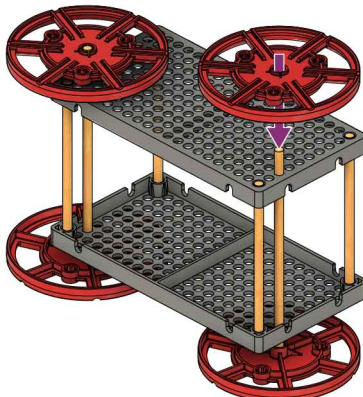

✓ You're ready to roll! Next, you'll add rubber bands.



Want to learn about gravity using your car?

Download the **Ramp Roll Lab** at teachergeek.com/rubberband Ages 9+

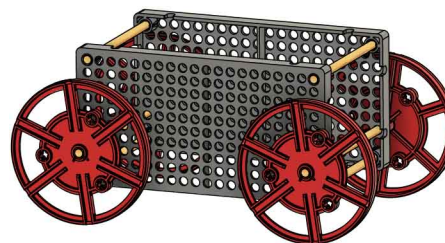

POWER UP

- 6 Snap a stop clip onto one of the axles. An adult may need to help snap the clip on.

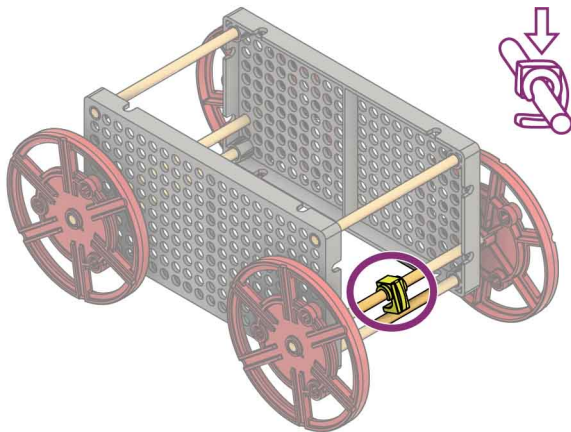

- 7 Cut two 1 cm (1/4 in) pieces of slide stop.

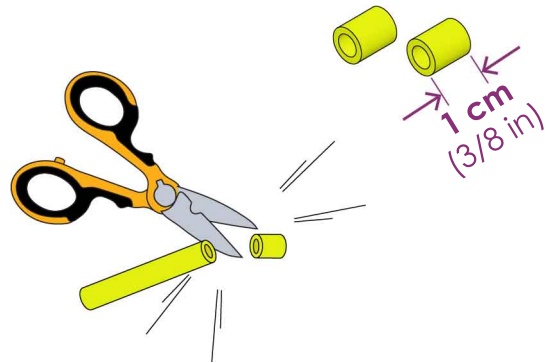

- 8 Insert a 13 cm (5 in) dowel through the frame and a rubber band, as shown.

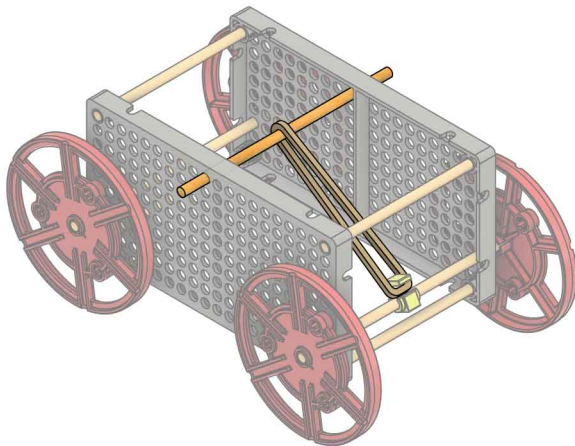

- 9 Add the slide stop to each end of the dowel.

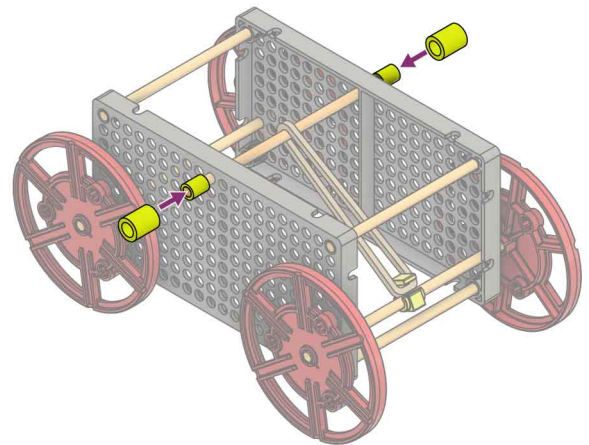

- 10 Test it out. Make sure the rubber band is hooked to the clip, then wind it up and release it!

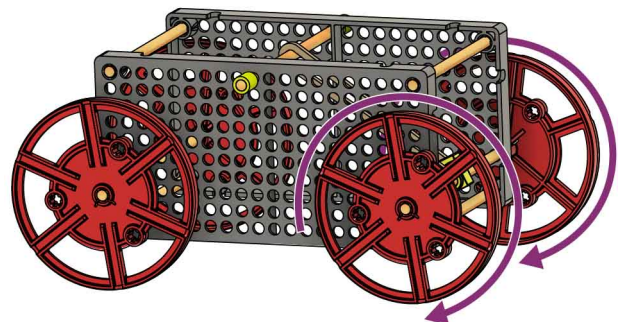

GET A GRIP

- 11** Place rubber band tires on your drive wheels to increase traction.

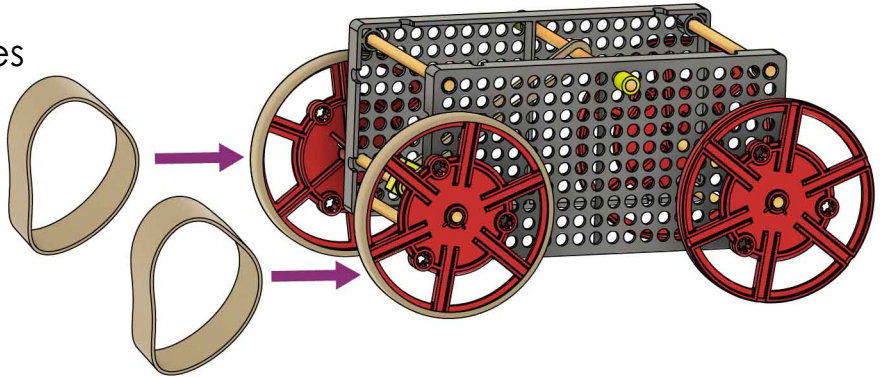

TRACTION

Traction is the friction between the wheels and the ground. It lets the vehicle push on the ground to move forward.

- 12** Try adding more rubber bands to your racer.

Do the rubber bands release their energy too fast?

Can you redesign your racer so rubber bands release energy slower?

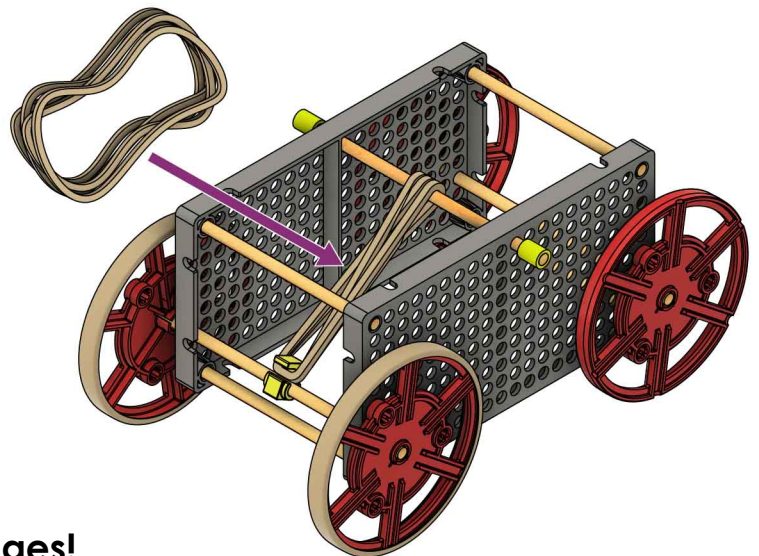

It's time for labs and/or challenges!

Complete one of the optional labs below or continue on to set up for the engineering challenge!

Optional Labs:

Ramp Roll Lab
(Ages 9+)

Energy Lab
(Ages 12+)

Atwood's Machine Lab
(Ages 14+)



Download these labs at
[teachergeek.com/rubberband](https://www.teachergeek.com/rubberband)

TROUBLESHOOTING

The **RACER** is **STOPPING**

Check for wheels rubbing the frame. Add slide stop as a spacer, if necessary.

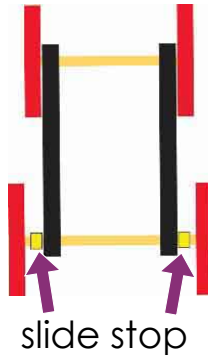

Make sure the wheel's boss (bump) is on the inside to make more space.



The **RACER** is **TURNING**

Make sure the frame and axles are straight and symmetrical.

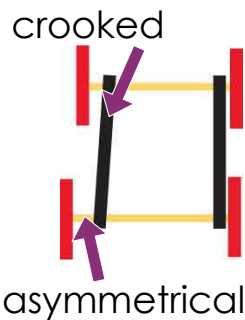

The wheels should be close to the frame (not touching), so they can't bounce around.

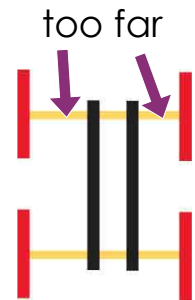

The **CLIP** is **SPINNING**

Glue the stop clip to the dowel. Hot glue and super glue work well.

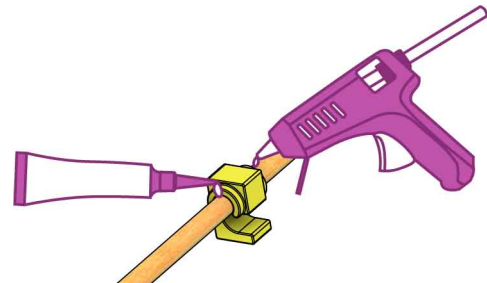

The **WHEELS** are **SLIPPING**

Add tire rubber bands to your drive wheels, if you haven't already.

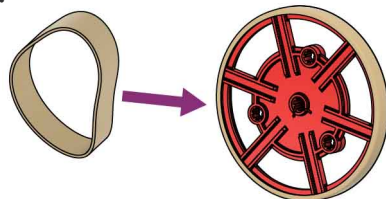

Slow the energy transfer by using a lever or rearranging your rubber bands. See Page 7.

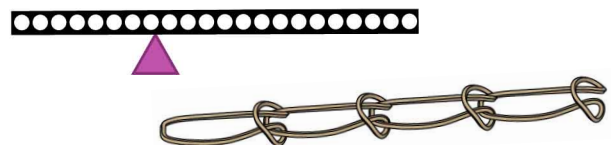

LONG SHOT CHALLENGE

Make your racer go the farthest!

Your rubber band racer must travel the furthest distance down the track.

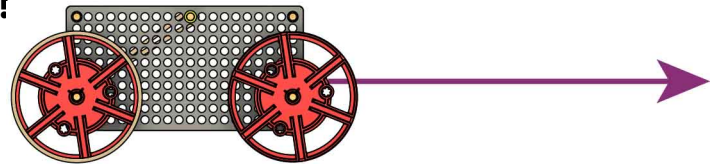

Constraints:

(rules and limits for your design)

Components: You may only use the TeacherGeek components listed on Page 1.

Size: At the start of the competition, vehicles must fit within a 50 cm x 50 cm x 50 cm cube.



There is no limit on recycling bin materials, but they can't power your racer.

Power: Only 5 small rubber bands may be used to power your vehicle. The tire rubber bands may not be used to store or release energy.

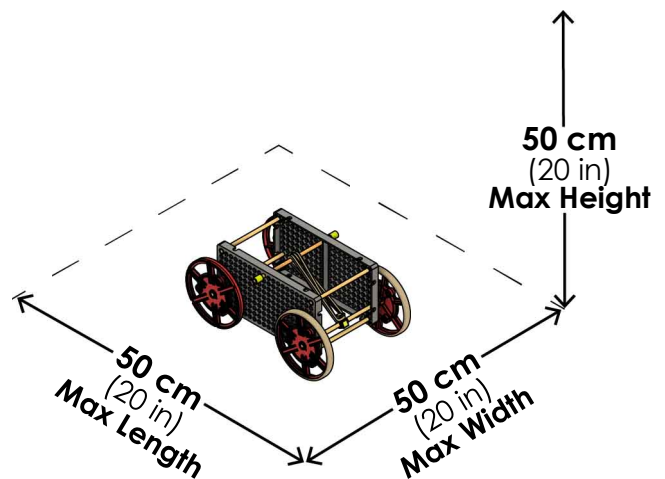

MORE CHALLENGES

Sprint:

Compete for the fastest time on a 3 m (10 ft) track.

The fastest racer wins!

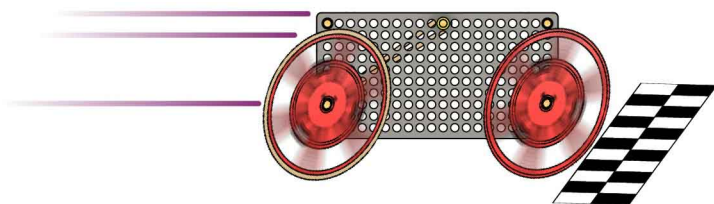

Target:

Design your racer to stop as close to the bullseye as possible.

The closest racer wins!

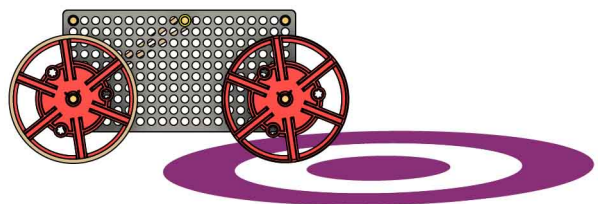

IMPROVE THE DESIGN

Parallel or Series

Chaining rubber bands in series releases energy slower than rubber bands in parallel.

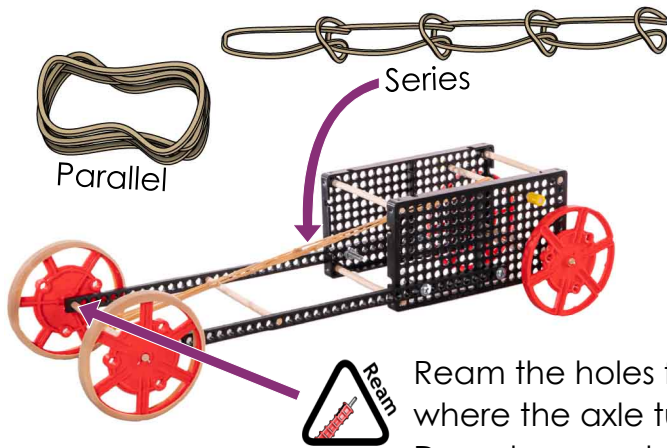

Use Pulleys

Pulleys can change the direction of a rubber band or string. Dowels that can spin can be used as pulleys.

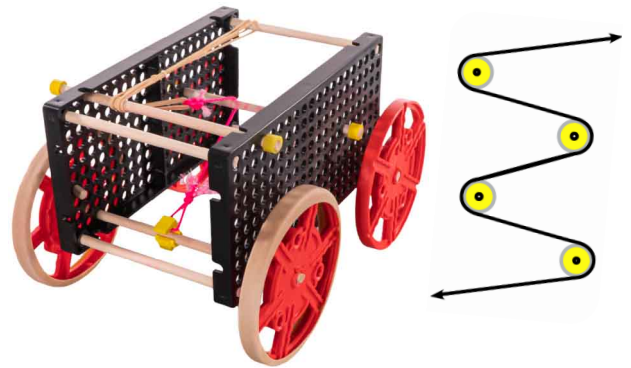

Add a Lever

Levers slow down or speed up the energy transfer.

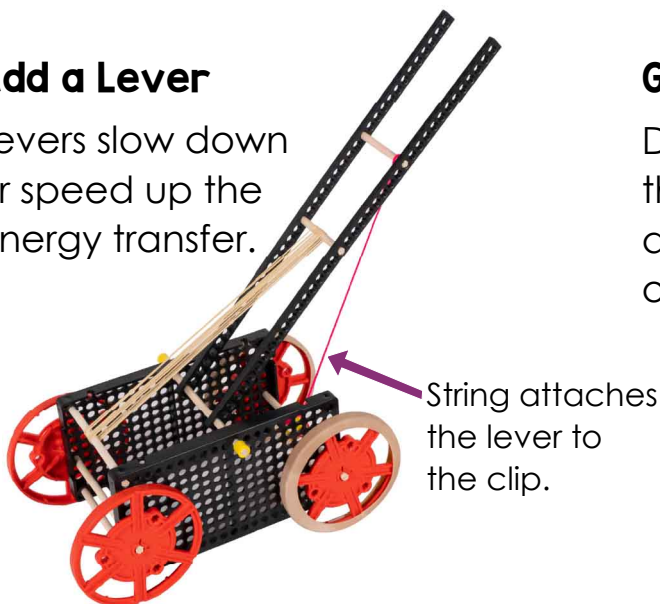

Get Crazy!

Don't just copy these. Experiment and create your own designs!



Tip

Cut or snap strips to the length that you need.

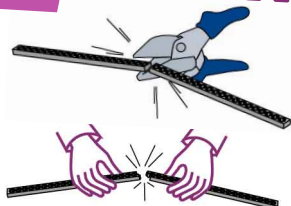

(start here)
DESIGN

TEST

DESIGN PROCESS

EVALUATE

REDESIGN

The Design Process never ends. There is no perfect design.