

Ready, Set, Drone! 3rd Edition

Grades 4-8

CURRICULUM SAMPLE



edventures.com

sales@edventures.com

(800) 429-3110



COMPLETE PROGRAM



PRINT CURRICULUM



REFILL KIT



Ready, Set, Drone! Third Edition

GRADES: 4-8

STUDENTS

Up to 30

TIME

12, one-hour lessons

SUBJECTS

- Physical Science
- Technology
- English Language Arts Connections

SETTINGS

- Summer Camps
- Classrooms
- Before & After-School Programs
- Homeschools

Take to the skies with easy-to-operate mini drones! Collaborative lessons combine brick-building activities with piloting skills while exploring drone safety, real-world applications and the physics behind UAV flight.

🔄 refill kit available

TECH REQUIREMENTS

- *Droneology Jr* Website: One device per student (digital curriculum is compatible with Internet-connected Macs, PC's, iPads, Android tablets and Chromebooks.)

PRICING OPTIONS

- Complete Program: \$2,995⁰⁰
- Curriculum Print & Digital: \$995⁰⁰
- Refill Kit: \$350⁰⁰

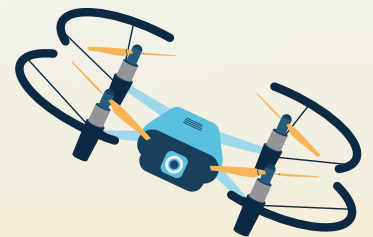

SCAN OR CLICK QR CODE FOR:

PRODUCT ORIENTATION

FULL MATERIAL LIST

STANDARDS & ALIGNMENT

CONTACT US:

Call: (800) 429-3110

Email: sales@edventures.com

Web: edventures.com





Learn the Controls



STEM CONNECTIONS

Technology: Empowered Learning & Collaboration



DURATION

60 Minute Lesson



MATERIALS

- Set of student computers or printed copies of Droneology Jr.: Piloting Skills quizzes (1 per student)
- Computer connected to a projector
- Pencils (1 per student)
- Radio Controls and Drone Controls handouts (1 of each per student)
- Safety glasses (1 per student)
- Science notebooks (1 per student)
- 6 Bins assorted bricks (1 per group)
- 6 sets of drones and controllers (1 per group) with charged batteries
- 12 Scissors (2 per group)
- 12 rolls of tape (2 per group)
- 30 Flight Team Lanyard Badges (1 set per group)
- Ready Set Drone Daily Slides (optional but recommended)

SCHEDULE

- Recap (5 min.)
- Droneology Jr.: Piloting Skills (30 min.)
- Second Flight: Piloting Practice (15 min.)
- Debrief (10 min.)

OBJECTIVE

Learn the four main flight controls of a drone and complete a mission as a flight team.

ALIGNED STANDARDS

Today follows up on camper's open exploration of drone flight from the day before with a lesson on flight controls and basic piloting skills. Campers write their ideas in their notebooks, talk about them one-on-one and in teacher-led discussions and interpret the information communicated through the *Droneology Jr.* videos. The quiz assesses what campers have learned about these fundamental drone concepts and terms. At the end of the lesson, there is a chance to apply this new knowledge and practice the skills learned in the previous lessons during a second flight session.

Common Core State Standards (CCSS):

CCSS.ELA-LITERACY.SL.4.1/CCSS.ELA-LITERACY.SL.5.1/CCSS.ELA-LITERACY.SL.6.1: Engage effectively in a range of collaborative discussions (one-on-one, in groups, and teacher-led) with diverse partners on grade 4-6 topics and texts, building on others' ideas and expressing their own clearly.

CCSS.ELA-LITERACY.SL.4.2: Paraphrase portions of a text read aloud or information presented in diverse media and formats, including visually, quantitatively, and orally.

CCSS.ELA-LITERACY.SL.5.2: Summarize a written text read aloud or information presented in diverse media and formats, including visually, quantitatively, and orally.

CCSS.ELA-LITERACY.SL.6.2: Interpret information presented in diverse media and formats (e.g., visually, quantitatively, orally) and explain how it contributes to a topic, text, or issue under study.

International Society for Technology in Education (ISTE) Standards for Students:

1d: Students understand the fundamental concepts of technology operations, demonstrate the ability to choose, use and troubleshoot current technologies and are able to transfer their knowledge to explore emerging technologies.

7c: Students contribute constructively to project teams, assuming various roles and responsibilities to work effectively toward a common goal.

21ST CENTURY SKILLS

- Communication and Collaboration
- Information, Media and Technological Literacy

HABITS OF MIND

- Thinking Interdependently
- Managing Impulsivity

KEY TERMS AND BACKGROUND INFORMATION

Drones are generally configured to respond to four essential controls:

- **Throttle:** moves the drone up and down. The throttle is controlled by up/down movement of the left joystick. A more mathematical definition is that throttle controls the drone's motion along its z-axis.

- **Yaw:** rotates the drone around a central point. By adjusting the yaw, the drone is able to face different directions. Yaw is controlled by the left/right movement of the left joystick. Yaw can also be described as a rotation around the z-axis.
- **Roll:** tilts the drone to the left or right, causing it to fly side to side. Combined with pitch, roll allows for banked turns. Roll is controlled by left/right movement of the right joystick. Mathematically speaking, roll is rotation around the x-axis stretching from the drone's nose to tail.
- **Pitch:** tilts the drone forward or backward, causing it to fly forward and backward. Pitch is controlled by up/down movement of the right joystick. Another definition for pitch is rotation around the y-axis.

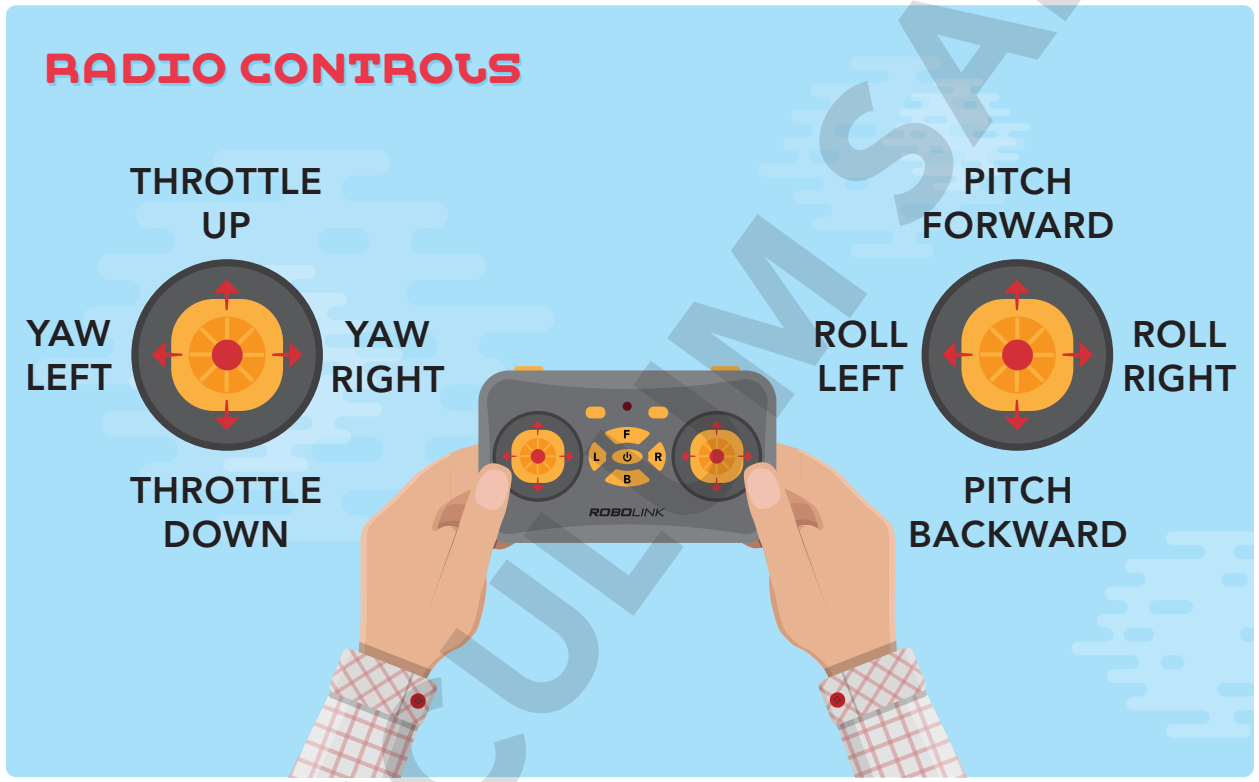

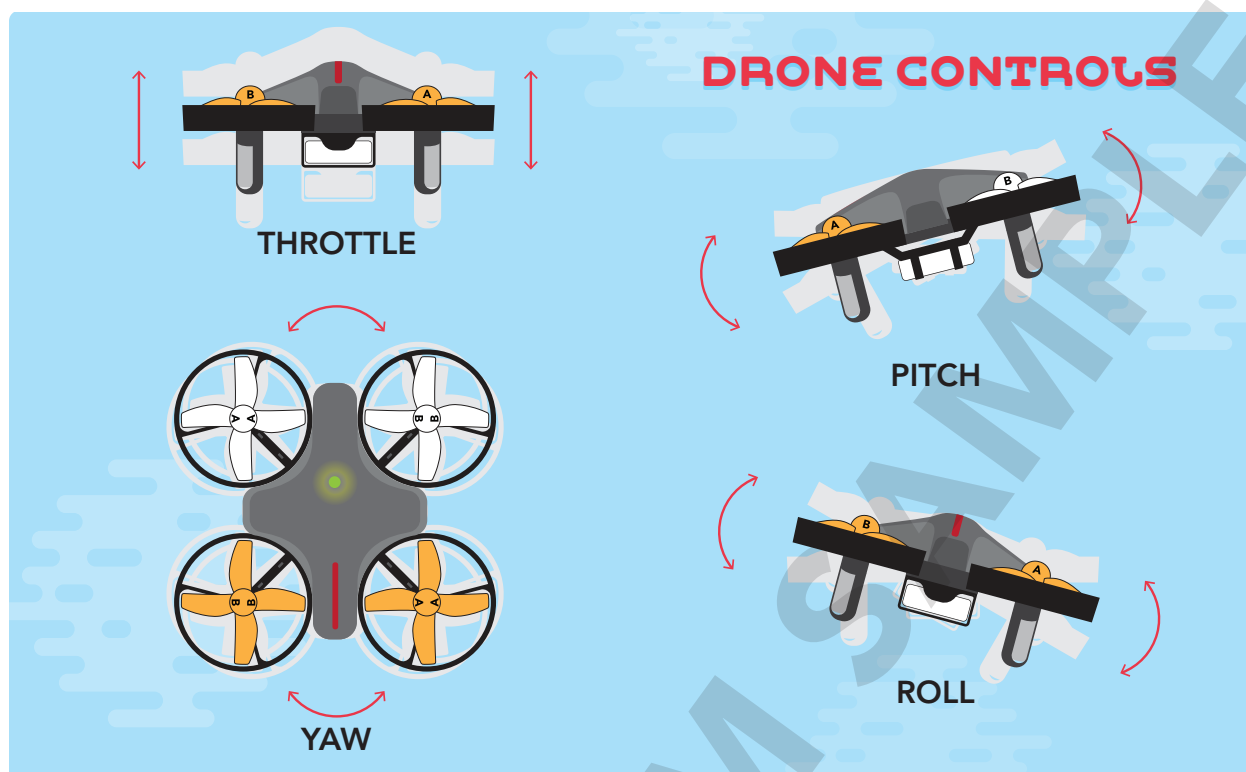

The most important thing for new pilots to know right now are the four terms describing each flight maneuver. This gives everyone a common language to coach each other and the ability to immediately respond to important commands, such as “throttle down!” Lessons later in the curriculum include a deeper dive into the physics behind drone flight.

DAILY PREP

CoDrone Mini Resources: <https://learn.robotlink.com/product/codrone-mini/>

- Have a drone and at least two batteries fully charged for each flight group.
- Set up a computer connected to a projector to show the Droneology Jr. video.
- Chop the Radio Controls and Drone Controls handouts into individual sections, if possible. If not, plan to hand out scissors for campers to cut apart themselves.
- Review the CoDrone Mini Quickstart Guide and Video Resources at <https://learn.robotlink.com/product/codrone-mini/> as needed to make sure you’re ready to show campers how to differentiate between the two types of propellers and safely replace a broken prop.
- Find a wide, open space, such as a gymnasium, so campers can spread out for flight practice.

STEP-BY-STEP DIRECTIONS FOR INSTRUCTORS



Whole Group Discussion

RECAP

Welcome campers back and start by asking what they remember from the previous lesson. The whole group Plus/Delta Chart is a great resource to revisit if it's still available. (If you're combining several lessons into a longer block and are transitioning directly from Day 2, move straight into the focused discussion of drone controls below.)

In the open flight exploration time in the lesson before, campers were challenged to experiment with the drone. Ask the class to share what they figured out:

- How were you able to control the drone's movement?
- What do you think the left and right stick do?
- What questions do you have about controlling the drone?
- Were you able to land on the landing pad?

Many groups may have already mastered the four main drone controls. If so, ask these experts to share their expertise with the group. Or, controlling the drone may have been an area where campers wanted to improve or learn more. After you've had a good discussion, let everyone know that the next video breaks down all four controls and shares the aviation terms for each one.



Notebooks

DRONEOLOGY JR.: PILOTING SKILLS

To prepare for the next Droneology Jr. video, have everyone add a new entry to their science notebooks: Radio Controls. Tape the Radio Controls and Drone Controls diagrams on the next two blank pages and update the Table of Contents.

Table of Contents

1	What is a Drone?
2	Parts of a Drone
3-4	Drone Safety
5-6	Launchpad Engineer's Sketch
7	Flight Log
8	Plus/Delta Chart
9-10	Radio Controls

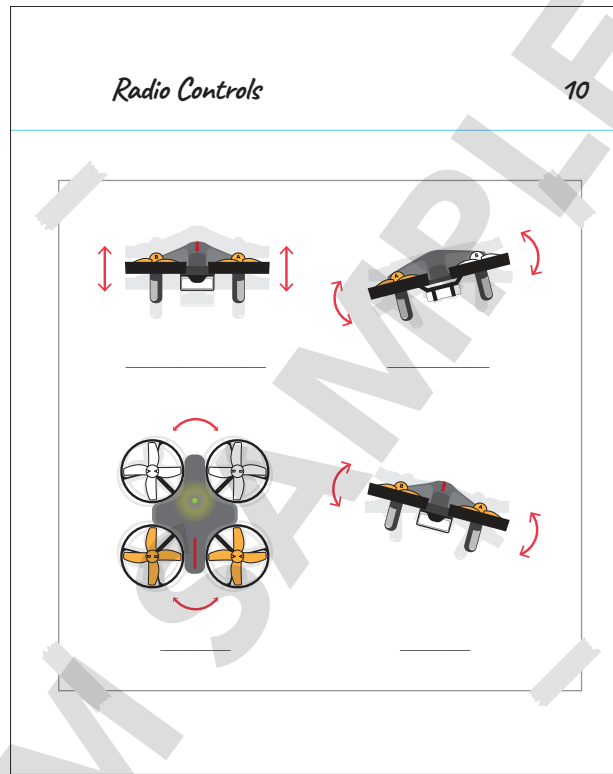
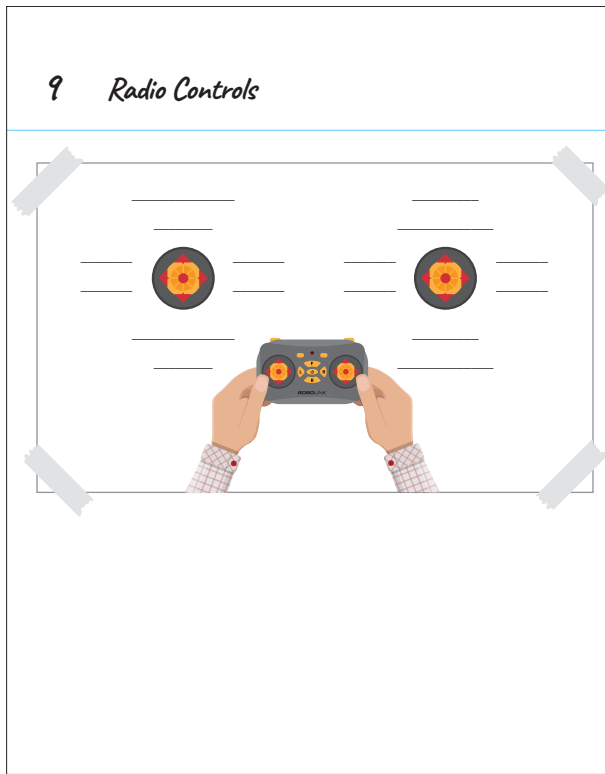

The Radio Controls and Drone Controls diagrams include blanks for campers to write the terms for each control (e.g. "throttle up" or "roll left") and images showing the motion for each control. Have campers fill in any terms they already know.



Video

Then, watch the *Droneology Jr.: Basic Piloting* video all together, listening for the missing information.



Notebooks

After the video, have campers add new information to their notes and share with a partner. Then review as a whole group so that everyone has a complete set of notes. As you're doing this final review of the commands, have your group physically get up and act out throttle, pitch, roll and yaw:

- Bend knees or stand on tiptoes while staying upright for throttle.
- Bend forward and back from the hips for pitch.
- Bend side to side from the hips for roll.
- Twist your entire torso to look left or right for yaw.

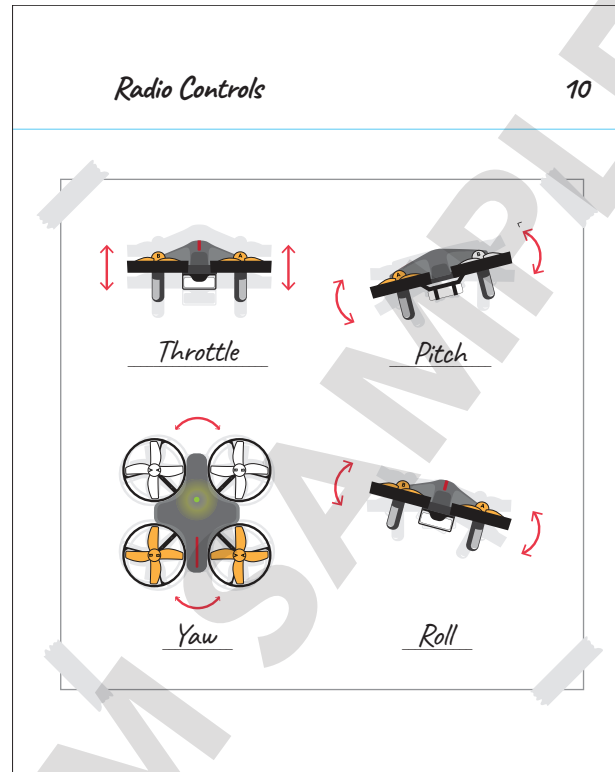
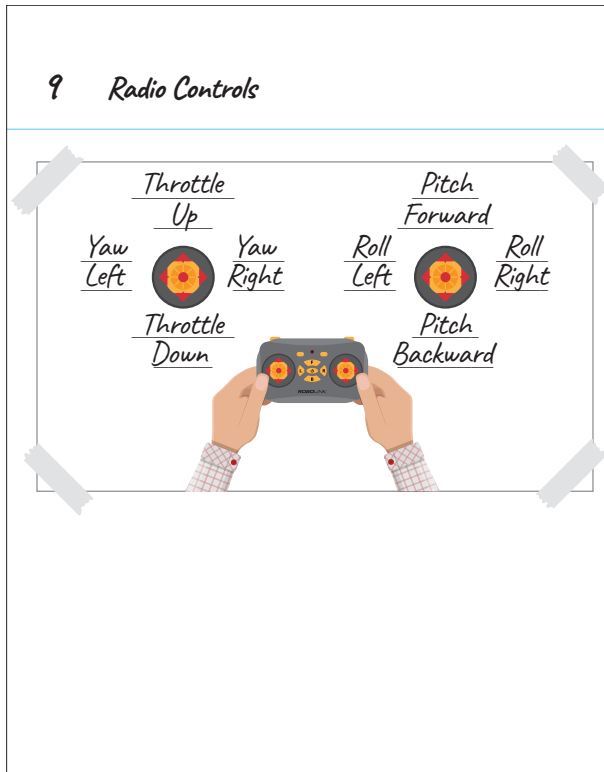

Quiz

Then, wrap up with the Piloting Skills quiz. Consider making the quizzes open-book and allowing campers to use the information they recorded in their notebooks. Depending on how your learners are accessing the Droneology quiz, either:

- Use the projector to take the quiz as a whole class.
- Show campers how to sign into their Droneology accounts and navigate to the quiz (everyone will need a unique email).
- Hand out a paper version (master copies are found in the appendix of the Instructor Guide).

If campers find any particular questions confusing or difficult, take some time to review with the group. Otherwise, with this new knowledge in hand, it's time for everyone's second flight!

Note: if you started today by testing landing pads or are running short on time, this is a good place to wrap up. There's plenty of flight time in the next lesson.



Whole Group Discussion

SECOND FLIGHT

Before launching into flight time, ask all campers to assume the role of the Mechanic and lead a mini-lesson on how to troubleshoot common drone repairs:

- How to differentiate between the two different types of propellers and where to find replacements.
- How to safely replace a broken propeller.

Finally, hand out Flight Team Lanyard Badges and review piloting team roles and pre-flight safety:



PILOTING TEAM ROLES

- **Pilot:** holds the controller and flies the drone.
- **Spotter:** can help coach the pilot and keeps an eye out for obstacles or hazards the pilot may not see.
- **Safety Officer:** makes sure the team is following all safety protocols.
- **Mechanic:** manages all drone materials and makes any repairs.
- **Engineer:** manages all brick materials and makes any needed modifications.

(For groups with less than five members, the Mechanic and Engineer roles can be combined, or the Safety Officer can assume both responsibilities.)



PRE-FLIGHT CHECK

- Always wear safety glasses, whether you're piloting or observing.
- Always perform a pre-flight check before powering on the drone:
 - Make sure the area is safe for piloting.
 - Check your propellers for nicks or other damage.
 - Check your battery: if it's cracked or puffy, swap it for an undamaged one.
- Have a plan to control a runaway drone.
- Don't keep flying when the drone signals that its battery is low. Land right away and replace the battery with one that's fully charged.
- Before picking up a drone that's landed, make sure the motors are completely off and the propellers have stopped spinning.
- Know the plan in case there's a fire or someone needs first aid.



Flight Time

With the flight briefing complete, have groups grab their launchpad and drone and spread out as much as possible to give plenty of room for piloting practice. Repeat yesterday's challenge of lifting off from the launch pad, experimenting with the controls and then landing back at the same spot.

Note: if campers need to rebuild their launchpads, have the Mechanic and Engineer revisit their engineering plans to quickly recreate their design while the Pilot, Spotter and Safety Officer start their first flight. It's okay if teams want to improve on their first idea based on their experience from the first flight. Have everyone scribe these new ideas in their notebooks.

Encourage groups to rotate roles every few minutes so that each group member has a turn in each role.

At the end of the day, make sure each group powers down, returns their drone and removes its battery. Set out a bin for batteries that need to be charged and return fully charged batteries to the LiPo safe storage bag. If you're able to, save the launch pads for groups to reuse later on. However, if you need to reuse the bricks for another group, have campers break down their launch pads.



Whole Group Discussion

DEBRIEF

Come back together as a group and debrief:

- Were groups able to complete the flight challenge and land back on their pads?
- How did the second flight compare to the first?



Notebooks

To record and reflect on their second flights, have campers update their flight logs and add a second entry to their Plus/Delta Charts. At the end of the day, collect everyone's drone notebooks and pencils.

7 Flight Log				
Date	Flight #	Aircraft	Duration	Notes
12/6/24	1	CoDrone	3 min	:(crashed
12/7/24	2	CoDrone	5 min	:) didn't crash

8 Plus/Delta Chart		
	+ (Things that went well)	△ (Things to change or work on)
12/6/24	First entry	First entry
12/7/24	Second entry	Second entry

EXTENSION: Simon Says

Play a game of Simon Says to practice radio control vocabulary:

- **Throttle up:** Stand on tiptoes while staying upright.
- **Throttle down:** Bend knees while staying upright.
- **Pitch forward:** Bend forward from the hips.
- **Pitch backward:** Bend backward from the hips.
- **Roll left:** Bend to the left from the hips.
- **Roll right:** Bend to the right from the hips.
- **Yaw left:** Twist your torso to look left.
- **Yaw right:** Twist your torso to look right.



Need a Custom Solution?

Call: (800) 429-3110

Email: sales@edventures.com

Web: edventures.com

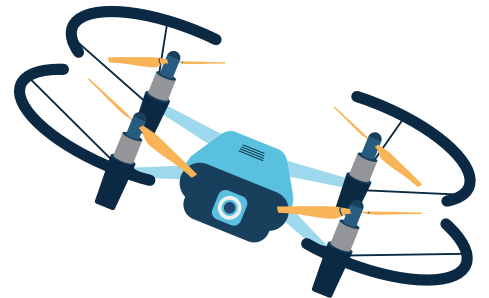
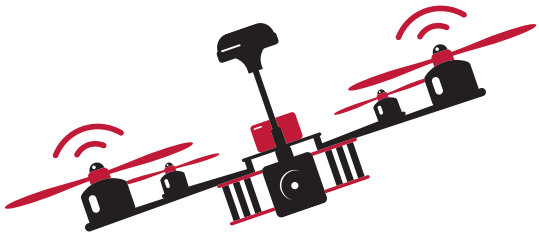

PCS edventures!™
Experts in Hands-On **STEM** Education

