

2-4 Put the cups with sand and soil onto two beakers to prevent water from leaking out when watering.



2-5 Take two new beakers and add the same amount of water to each. Pour two cups of water into the sand and soil separately.



2-6 After adding water, use BOSON soil moisture sensor to measure the moisture value of sand and soil again and record data in the table



Note 1: After measuring the humidity of one cup, clean the sensor probes and dry up before measuring the next one.



Note 2: Only the probes of the soil moisture sensor(yellow parts) are waterproof. Do not let other parts contact with water, otherwise, the sensor may be damaged.	
2-7 Next, measure the moisture value every 10 minutes and record data in the table.	

Activity Conclusion

The referable data is as follows:

	0min	10min	20min	30min	40min	12h
Sand	0	552	510	460	420	306
Soil	114	675	662	638	626	620

Observing the above table, we may find that the obtained data are not convenient for us to directly see the changes in soil moisture and sand moisture as time goes by. What should we do?

The data directly measured in the experiment is generally called the original data. In order to obtain the information we want, it is often necessary to process the original information. For example, in this experiment, we want to see the change in soil moisture as time goes by,

so we can subtract the original data at two moments to get the change over a period of time. As the table below.

	0-10min	10-20min	20-30min	30-40min	40min-12h
Sand	552-0	510-552	460-510	420-460	306-420
Soil	675-114	662-675	638-662	626-638	620-626

The results obtained are as follows, "+" means increase, "-" means decrease.

	0-10min	10-20min	20-30min	30-40min	40min-12h
Sand	+552	-42	-50	-40	-114
Soil	+561	-13	-24	-12	-6

From the above table, it can be concluded that within 10 minutes after adding the same amount of water, the sand moisture increases by 552 and the soil moisture increases by 561, which are relatively close. Every 10 minutes thereafter, the moisture value of the sand decreases more than that of the soil. Especially after 12 hours, the moisture of the sand decreases by 114, while the soil one decreases by only 6. It shows that the water loss in the sand is faster than that in the soil.

Therefore, we can draw the conclusion: the water storage capacity of sand is weak, and that of soil is strong.

Sand cannot hold water, and consequently it cannot provide water for plants. Even if it rains heavily in the desert, the rainwater will quickly run away from the sand, and it is still difficult for plants to survive.

Science Background

In the experiment, we first observed the particle size of sand and soil, and then explored the water storage capacity of sand and soil. Why can the soil hold more water? Does this have anything to do with their particle size? How do we distinguish sand and soil? Let's learn together!

How Does the Soil Hold Water?

In Part 1, we can see through a magnifying glass that the soil particles are nonuniform in size. Because of this, these soil particles are stacked together, leaving pores of different sizes between the soil particles. Most of the water in the soil is stored in these pores. This phenomenon is called capillarity. The capillarity allows water to overcome gravity and adhere to small pores.

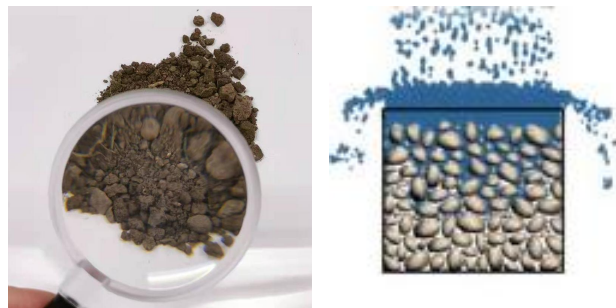

If it rains heavily, the pores of the soil are already full of water, and the excess water will be drained from the ground surface, forming a stream, and flowing to low-lying lakes, ponds, and ditches. If there is a continuous drought and there is no water in the pores of the soil, the soil will become dry, cracked and caked.



Why Cannot Sand Hold Water?

In Part 1, we can see through a magnifying glass that the sand particles are large and uniform. Because of this, the pores between the sand particles are also relatively large, and the capillarity generated is weak. Water will pass through the sand under gravity. This is why the sand cannot hold water.

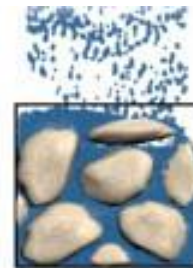

Learn Soil and Sand

Soil is a complex mixture of minerals, water, air, organic matter and countless creatures. The soil particles are of all sizes. Some scientists divide soil particles into three types: clay, silt and sand according to their diameter. So sand is actually a kind of soil!

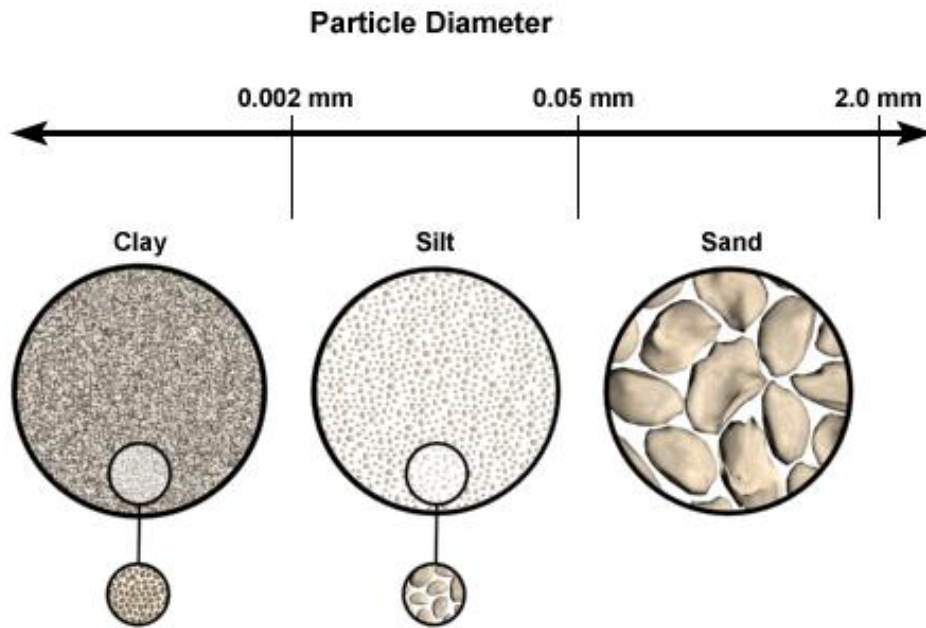

According to the proportion of clay, silt and sand in the soil, the soil can be divided into clay, loam and sandy soil.



Clay has small pores and strong capillarity, so it has a strong water storage capacity. Sandy soil has large pores and a weak capillarity, so the water storage capacity is weak. The water storage capacity of loam is between clay and sand, weaker than clay and stronger than sand.

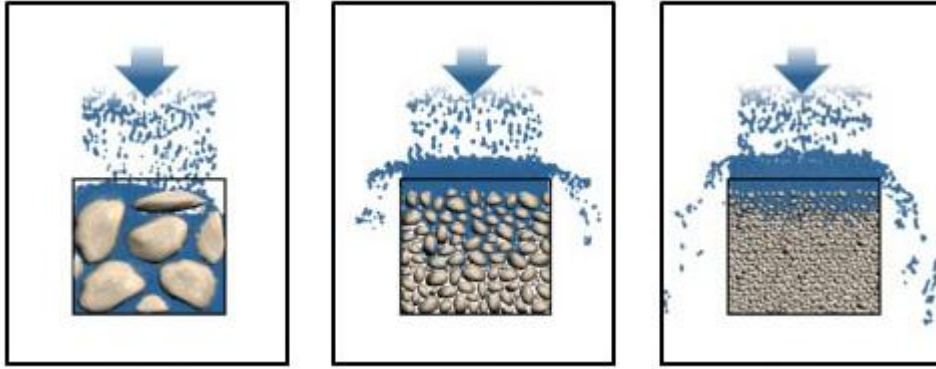

Conclusion

In this program, starting from “why there are few plants in the desert” , we learned the difference in water storage capacity between sand and soil through observation and experimental exploration.

The project is going to an end, please remove cables, and put all the BOSON modules back into the kit.

Extend

1. What are the characteristics of the roots of desert plants? And why is it?

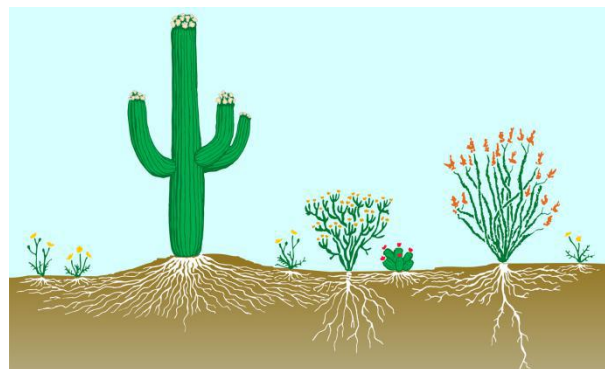

2. What is the climate like in the desert? Will this affect the water storage of sand?

3. Why does the land become a desert? How can we prevent desertification?



LESSON 7: How Does the Water Cycle Work?



Introduction

Standards

NGSS

5-PS1-1 Develop a model to describe that substance is composed of small and invisible particles

5-PS2-1 Demonstrate that the gravity effect of the earth on objects is downward

5-ESS2-1 Develop a model to describe how the lithosphere, biosphere, hydrosphere, and atmosphere interact with each other.

MS-ESS2-4 Develop a model to describe the circulation of water in the earth system driven by solar and gravitational potential energy.

Science - Grade 3-5



Overview



This lesson will lead students to think about the question "where does the rainwater come from and where does it go?", observe the movement of water droplets on the glass of ice water. By using soil, water and plastic box to build a simple water cycle model, they will explore the formation process of the water cycle, learn the three forms of water and





the distribution of water on the earth, and understand the dynamic process of the water cycle and what role water cycle plays in the lithosphere, biosphere, hydrosphere and atmosphere.

Materials

BOSON Module	Image	Function
Battery Holder (3x AAA batteries installed)		4.5V Power Supply
MainBoard-1IO (m2)		Provide power for other modules
Soil Moisture (i16)		Measure the moisture of the soil

Display Module(o11)		Provide visible effect for users to check experiment results
BOSON cable *2		Cooperate with 3-Pin fool-proofing connector to connect other modules

Additional Materials	Image	Function
Water		It is used for experimental exploration.
Ice Cube		It is used for experimental exploration.

Storage Box		It is used to build the model of water cycle
Plastic Wrap		It is used to build the model of water cycle
Soil		It is used to build the model of water cycle
Ziplock Bag		It is used to hold the ice cubes, being an ice bag
Warm-Light Lamp		Generate light and heat like the sun (be careful not to use cold-light lamps, they only generate light without heat)

Engage

When it rains, we can see the rainwater dropping like beads. Have you ever wondered where does the rain come from? When the rain fell on the ground, the ground became wet; after the rain stopped, the ground slowly dried out. Where did the rain go?

In nature, there are many kinds of water, such as rainwater, seawater, etc. So, will the rain become less and less? Will the sea water amount increase continuously? Have your guess!



Explore

This experiment will be divided into two parts. In the first part, we are going to add some ice cubes into a glass of water, and observe the movement of water on the outer cup wall. In the second part, we are going to build a simple water cycle model, using soil and water to create land and ocean in the experiment box, and then explore the process of water cycle between land and sea.

Part 1 Observation: Is the Water Moving?

Add the ice cubes into the water, observe the changes on the outer cup wall, and record it in the table below.

	Before	After
The Outer Wall (Wet/Dry)		

Materials

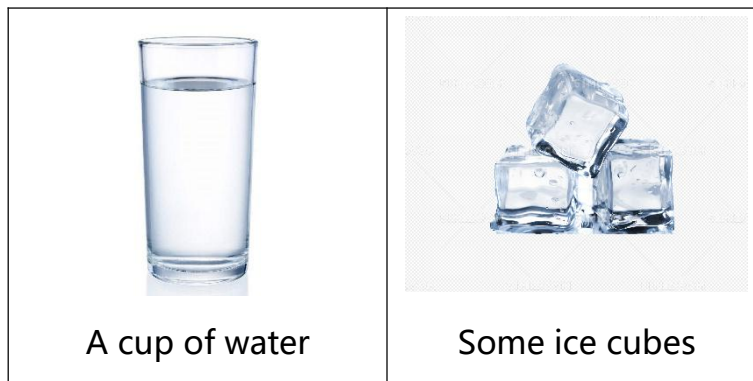

Step

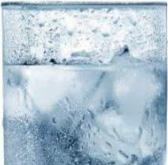
1-1 Prepare a cup of water at room temperature and dry the outer cup wall.	
1-2 Put the ice cubes into the water	

<p>1-3 Wait 5 minutes, touch the outer cup wall, observe whether it becomes wet, and record the result in the table.</p> <p>Note: it is recommended to perform this experiment in summer, the higher the room temperature is, the better the effect will be. If it is winter, it is best to turn on the indoor air conditioner and let the room temperature reach above 15°C, otherwise, you may not see obvious water droplets gathering on the cup wall</p>	
---	--

Activity Conclusion

The referable results are as follows:

	Before	After
The Outer Wall (Wet/Dry)	Dry	Wet

We see that the outer wall of the cup has become wet, and a lot of small droplets have gathered. Think about it, where does the droplets come from?

First of all, the small droplets must not flow out of the cup, or the cup is leaking. Considering that the outer cup wall is only in contact with the air, we speculate that there may be water in the air! It's just that the water in the air is so small that we can't see it. When it comes to a cold cup, the water in the air gathers together and becomes small drops on the outer cup wall!

In the same way, it can be speculated that the rain on the ground will dry out, perhaps it is because that the water on the ground returns to the air. The water in the air can gather on the cup wall, and the water on the ground can also return to the air. This indicates that the water is moving!

Conjecture

In nature, will water in rivers, lakes and seas move into the air? How did the water in the air turn into rain and return to the ground? How does the natural water cycle change? Let's continue to explore through experiments.

Part 2 Experimental Exploration: How Is Water Cycle Formed?

We are going to make a land-water model to explore the water cycle in nature.

In a plastic box, half of the space is the land created by soil and half is the ocean created by water. Seal the plastic box with plastic wrap to prevent water in the outside air from interfering with the experiment. Observe the formation process of the water cycle, and use BOSON soil moisture sensor to detect changes in soil moisture in the model



Materials

Prepare the following BOSON modules and other materials.

 <p>Display Module(o11)</p>	 <p>MainBoard-1IO (m2)</p>	 <p>Soil Moisture (i16)</p>
 <p>Battery Holder (3x AAA batteries installed)</p>		 <p>BOSON cable *2</p>
 <p>A Cup of Water</p>	 <p>Some Ice Cubes</p>	 <p>Storage Box</p>
 <p>Plastic Wrap</p>	 <p>Soil</p>	 <p>Ziplock Bag</p>

Step

1. First, build an experimental circuit to detect the soil moisture value.

1-1 Connect the Battery Holder and two Module Cables to the Main Board.

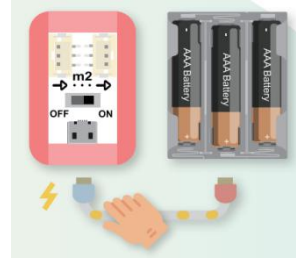

The cable's pin header should be plugged in completely so that it is not easy to pull it out.

1-2 Connect the Display Module to the output side of the Main Board with a Module Cable.

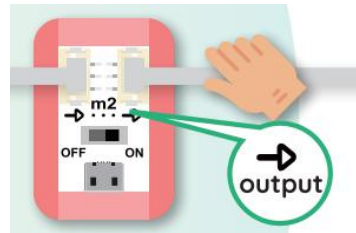

1-3 Connect the Soil Moisture to the input side of the Main Board with a Module Cable.

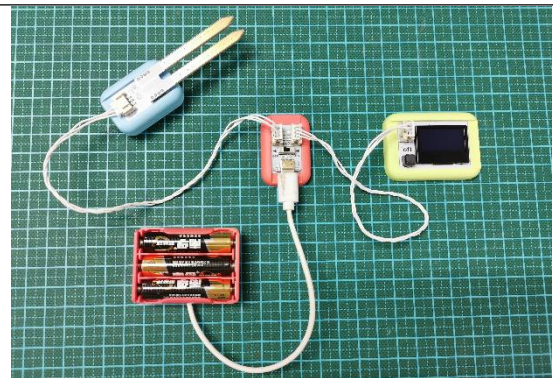

1-4 Dial the power module to "ON" . Press the black button at the lower-left corner of the display module several times until " i16 Analog Data" is displayed.



1-5 Hold the two probes of the soil moisture sensor with your hands, it will display the moisture of your hand. When releasing, the value will be 0.

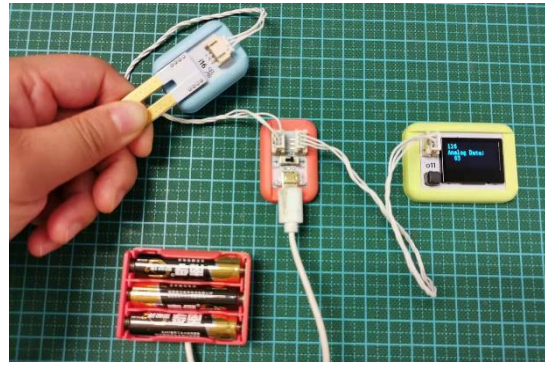

2. After completing the circuit connection, let' s build the water cycle model together.

2-1 Prepare a plastic box and pour the soil on one side of the box to simulate a land. Compact the soil.



2-2 Pour suitable water on the other side of the box to simulate an ocean.



2-3 Insert the soil moisture sensor into the soil.

Note: Except for the yellow probes of the sensor, other parts of the sensor cannot be exposed to water, otherwise the sensor may be burnt.



2-4 Seal the box with plastic wrap and stick the plastic wrap with tape



2-5 Put some ice cubes into the zip lock bag to make an ice bag



2-6 Place the ice bag on the plastic wrap on the top of the box, above the soil.



2-7 Select a warm and sunny day, place the model under the sun to heat it up. If the weather is bad, you can use a warm-light lamp to heat it.



2-8 Try not to touch the model during the experiment. Record the value of the soil moisture sensor every 10 minutes.



Soil Moisture Value Table:

Time	10min	20min	30min	40min	50min
Moisture Value					

Activity Conclusion

Soil Moisture referable data:

Time	10min	20min	30min	40min	50min
Moisture Value					

Through the experimental data, we can know that although the moisture of the soil does not change much, the value is still generally getting higher.

In the water cycle model we created, we can clearly see that under the heating of the sun, the plastic box is full of water vapor. This is because the water in the "lake" evaporates into the air. When the water in the air increases, encountering the cold ice cubes on the plastic wrap, it will

condense together and turn into small droplets, and then drop into the soil. Is this similar to the process of rain?

By the same token, in nature, the heat of the sun will cause the water on the sea surface to evaporate into the air, and it will condense in the sky and form clouds. With more and more small droplets in the clouds, rain will form and fall on the ground, flow into the river, and eventually part of the water return to the ocean. This is the water cycle!

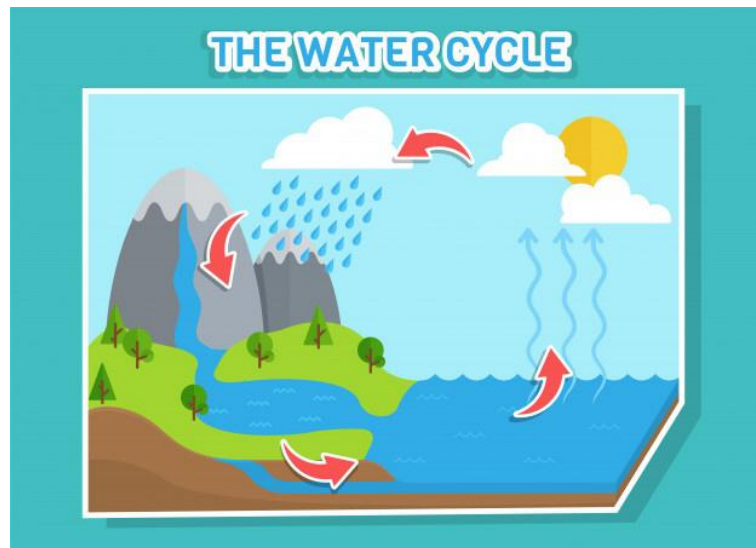

Science Background

Through experiments, we have a general understanding of the water cycle among the ocean, air and land. Let' s get to learn the water cycle between water and nature together!

Three Forms of Water

We all know that when water freezes, it turns into ice, and boiling water will evaporate into water vapor. In physics, ice is called solid water, water

We can see the white steam on the boiling kettle mouth, because the water vapor is cooled by the surrounding air and turned into small droplets.

Water Cycle in Nature

Due to the three types of changes of water form, the water in nature can circulate continuously.

The heat of solar radiation evaporates a large amount of water from the sea, lakes, rivers and land, turning into water vapor and moving into the air. When the water vapor in the air encounters cold temperature, it will turn into a cloud, and more and more water droplets in the cloud will fall to the ground as rain or snow. The rainwater that falls on the ground may evaporate again, or it may be transformed into groundwater, soil water and surface runoff, and eventually part of the water returns to the ocean, thus a natural cycle is formed.

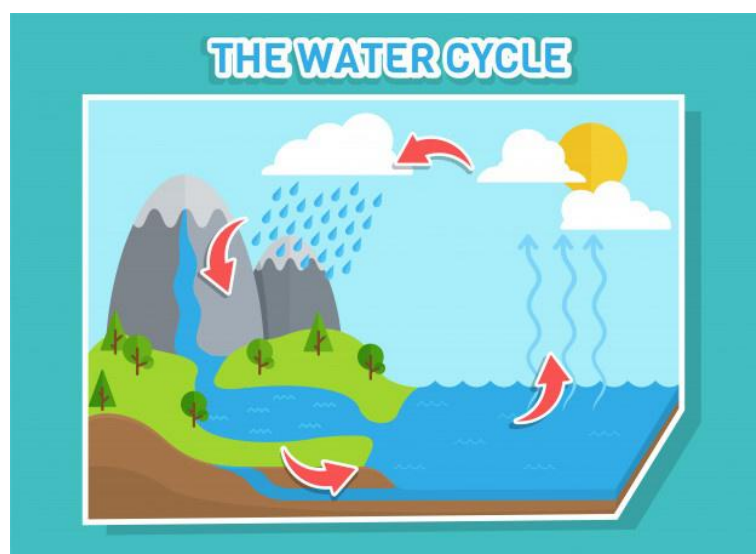

The Water Cycle and Other Cycles

The water cycle drives the interaction among the lithosphere, biosphere, hydrosphere, and atmosphere on the earth, and is the "tie" that connects the earth's circles and various water forms.

The water cycle is a "regulator", it regulates the energy among the various layers of the earth, and plays an important role in the change of cold and warm climate. The water cycle is the "sculptor", which shapes the colorful surface forms through erosion, transportation and accumulation. The water cycle is the "conveyor belt", it is the powerful driving force and main carrier of the surface material migration. More importantly, through the water cycle, the ocean continuously delivers fresh water to the land, supplementing and renewing fresh water resources on the land, thus making water a renewable resource.

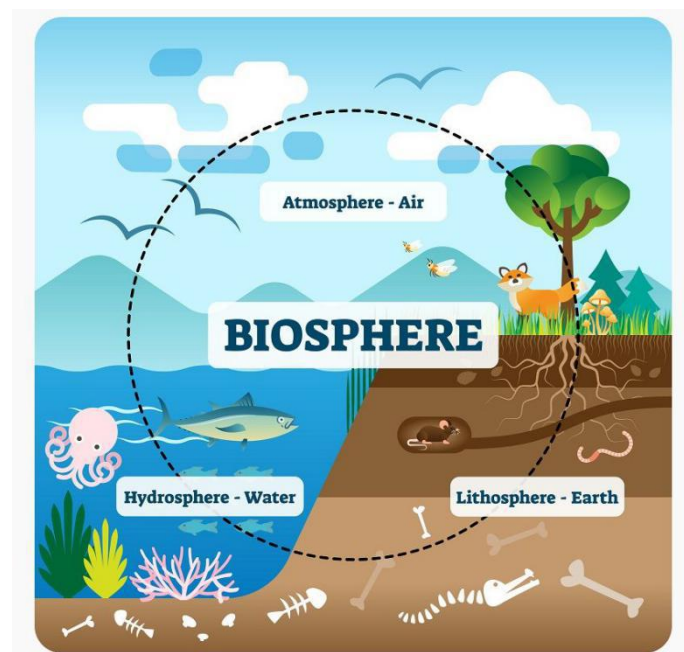

Conclusion

In this project, we started from "where does the rain come from, and where does it go?", through a cup of ice water, observed the phenomenon of water movement. Then built a simple water cycle model, explored the formation process of the water cycle, and learned the knowledge of water and water cycle.

The project is going to an end, please remove cables, and put all the BOSON modules back into the kit according to the corresponding position.

Extend

1. Water will become larger when it freezes into ice. Why is this? Try to explain from the perspective of water molecules.
2. In autumn and winter mornings, heavy fog often affects our sight. Do you know how the fog is formed?
3. Why do we feel the air more humid in places with many trees?

LESSON 8: Solar Oven

Introduction



Standards

NGSS

4-PS3-2 Make observations to provide evidence that energy can be transferred from one place to another via sound, light, heat, and current.

4-PS3-4 Use scientific concepts to design, test and improve the equipment that can transform energy from one form to another.

Science - Grade 3-5

Overview

We all love barbecues, but smoke produced by grilling often contains pollutants that damage health. Can we utilize pollution-free solar energy to cook food? In this lesson, we are going to make a solar oven to cook chocolate sandwich biscuit based on the principle of light reflection.

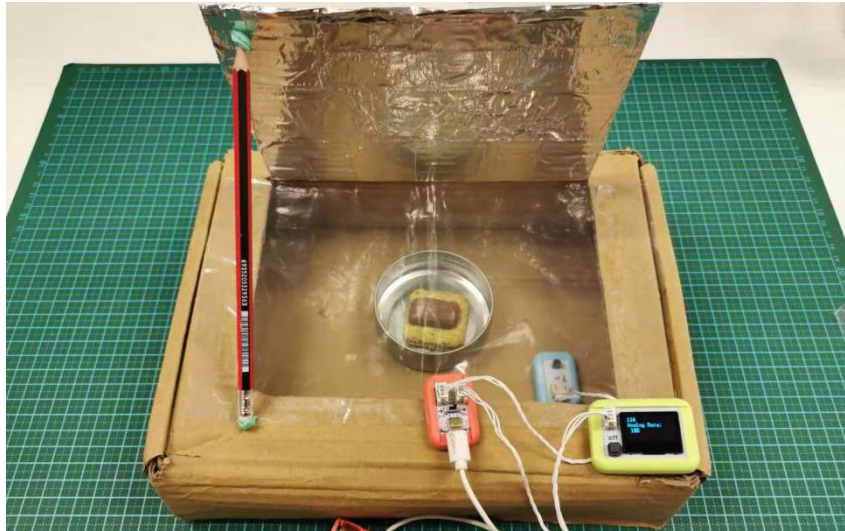



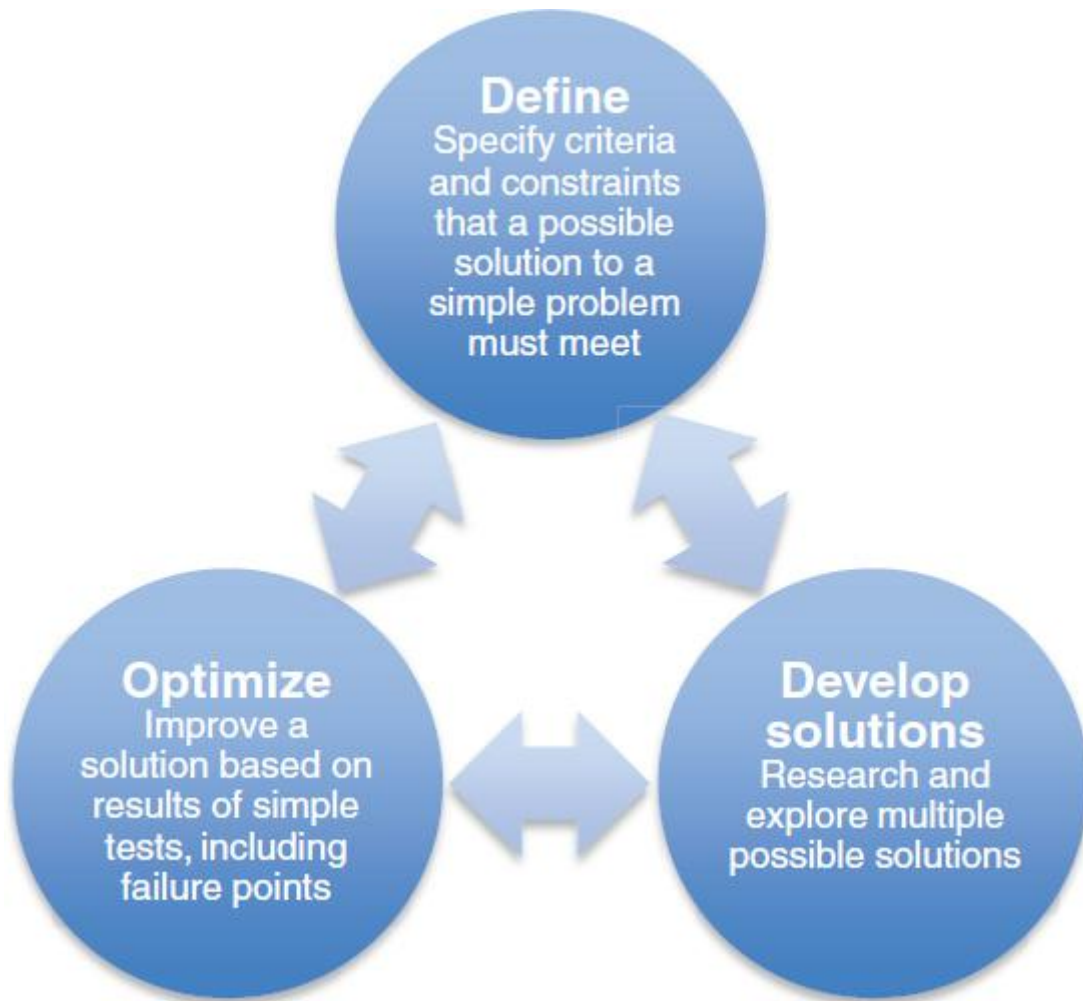

According to the NGSS standard engineering design requirement in 3-5 grades, the course is divided into 3 parts, they are respectively “DEFINE ENGINEERING PROBLEMS, DEVELOPING POSSIBLE SOLUTIONS, OPTIMIZING THE DESIGN SOLUTION” . Just like engineers, students will find problems, set goals, design plans, build and test models, optimize and improve models, and finally complete the engineering design task.



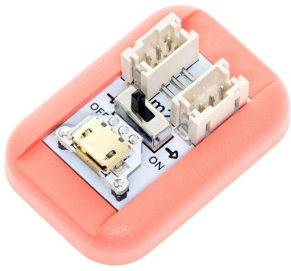











Materials

BOSON Module	Image	Function
Battery Holder (3x AAA batteries installed)		4.5V Power Supply

MainBoard-1IO (m2)		Provide power for other modules
Temperature Sensor (i11)		Measure the temperature in the oven
Display Module(o11)		Provide visible effect for users to check results
BOSON cable *2		Use with 3-Pin Fool-proof connector to connect other modules

Additional Materials	Image	Function
----------------------	-------	----------

<p>Pizza Box</p>		<p>Used to build the oven</p>
<p>Aluminum Foil</p>		<p>Used to reflect sunlight to make a reflective device</p>
<p>Plastic Wrap</p>		<p>Used to seal the pizza box to prevent heat loss</p>
<p>Double Sided Adhesive Tape</p>		<p>Used to stick the plastic wrap and aluminum foil to the pizza box</p>
<p>Paper Knife</p>		<p>Used to cut the pizza box (can be replaced by scissor)</p>
<p>Ruler</p>		<p>Used to measure the size</p>
<p>Pencil</p>		<p>Used to mark the cut position (can be)</p>

		replaced by pen)
Newspaper		Roll up the newspaper and place it around the pizza box to prevent heat loss
Metal Roasting Pan		Used to hold food
Chocolate		Food to be cooked in the oven
Biscuit		Food to be cooked in the oven
Lamp		When the outdoor light is not good, use a desk lamp as a supplementary light source

Blue Tack		Used to fix the sensors and other materials
Black Paper		Used to absorb heat generated by sunlight

Activity 1 DEFINE ENGINEERING PROBLEMS

Find Problems

Have you ever cooked outdoors? When grilling or camping outdoors, charcoal is often burned to heat food. This will pollute the environment to a certain extent. Is there an environmentally friendly method?

In the previous project, we have learned the concept of energy. Many kinds of energy can be converted into heat energy. For example, when burning charcoal, the chemical energy of charcoal is converted into heat energy. Think about it, what other energy can be converted into heat? Can it be convenient for us to cook food outdoors without polluting the environment?

Solar energy is a good choice. The sun's radiation can heat objects. Let's make a solar oven together!



Engineering Goals

Make a solar oven to cook food with the Sun.

Activity 2 DEVELOPING POSSIBLE SOLUTIONS

After determining the engineering goals, let us follow the process of “Brainstorming-Drawing Prototype Diagram-What You Need-What You Do-Test and Evaluate” to develop a solution and complete the building of a solar oven.

Brainstorm

Let’ s first brainstorm how to build a solar oven. In the process, try drawing a prototype of the solar oven.

Question	Referable Answer
1. What is the function of the solar oven?	Heat food with the sun.
2. How can we make a solar oven?	We can use a box as an oven, imitating the oven at home.







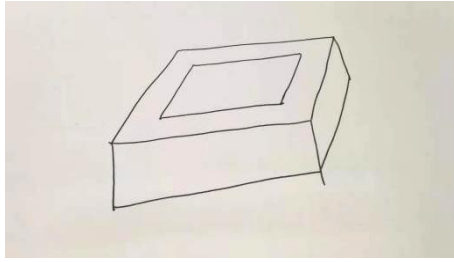



	<p>Also, we need to make an opening at the top cover of the box to allow direct sunlight to enter and heat the food.</p>
<p>3. How can we prevent heat loss?</p>	<p>Let the oven have insulation properties.</p> <p>For example, covering the opening of the top cover with a transparent plastic film can not only allow sunlight to pass through, but also prevent heat loss.</p> <p>Or, spreading multiple layers of old newspapers in the oven, which is like wearing many layers of clothes in winter to prevent heat loss.</p>

Prototype Drawing

In the brainstorming, we have initially understood the function and structure of the solar oven. Try drawing a prototype diagram. In the production process, the prototype diagram will be an important reference.



What You Need

		
<p>Pizza Box</p>	<p>Pencil</p>	<p>Paper Knife</p>
		
<p>Metal Roasting Pan</p>	<p>Chocolate</p>	<p>Biscuit</p>
		
<p>Double Sided Adhesive Tape</p>	<p>Plastic Wrap</p>	<p>Newspaper</p>
		
<p>Ruler</p>		

What You Do

1. Prepare a clean pizza box, a pencil and a ruler. Draw a square at the top of the pizza box, whose sides are 3cm away from the edge of the box.



2. Prepare a paper knife. Cut the square carefully along the three lines just drew, and then slightly fold back the flap along the connected side to allow the sunlight to enter the box.

Note: Do not cut off the flip cover completely.



3. Prepare plastic wrap and double sided adhesive tape. Cover the opening of the box with plastic wrap, and stick the plastic wrap on the box with double sided adhesive tape.



Make sure that there are no holes in the wrap and that all edges of the wrap completely cover the opening.

4. Prepare some newspaper. Open the top cover of the pizza box, roll some newspaper into a tube, and stuff it into the sides of the box.



5. Prepare chocolates, biscuits and a metal pan. Put the chocolate on the biscuits, and then place them on the metal pan, put the pan in the pizza box, and cover the top of the box.



Test and Evaluate

With the above steps, a simple solar oven is completed! On a shining day in the summer, at about 12 o'clock and 3 o'clock, put the solar oven

outside, then we can enjoy delicious chocolate sandwich biscuits after a while!

Do you think solar ovens can be optimized? Can the oven collect more sunlight to heat the food? Try to propose an optimization plan to improve the efficiency of the solar oven.

Activity 3 OPTIMIZING THE DESIGN SOLUTION

Let us continue the process of “ Brainstorming-Drawing Prototype Diagram -What You Need-What You Do-Test and Evaluate” to carry out optimization and iteration of solar ovens.

Brainstorm

Question	Referable Answer
1. How to heat food faster?	If more sunlight is available, food can be heated faster.
2. How to get more sunshine?	You can get more sunlight by increasing the area irradiated by sunlight, or gathering sunlight in one place by reflection. However, increasing the sun exposure area means a bigger oven is required, which will cause heat loss easily.
3. How to get more reflected light?	Add a reflective device so that the

	surrounding sunlight can be collected in the oven through reflection.
4. How to make a reflective device?	Aluminum foil is a great reflective material, which can be just stucked and fixed at the inner side of the flip at the top of the box, as a reflective device.
5. How to check the efficiency of the solar oven?	Measure the temperature change in the oven in real-time with BOSON temperature sensor to get the efficiency of the oven.

Prototype Drawing

Through brainstorming, we optimize the design of the solar oven, try optimizing the prototype figure, and mark the materials and functions of each part.

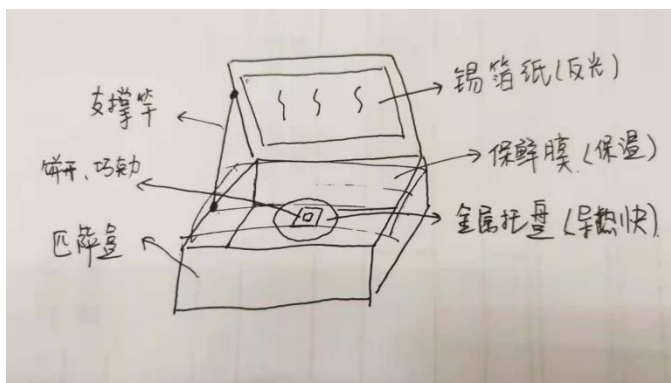

What You Need

Prepare the following BOSON modules and other materials.



Display Module(o11)



MainBoard-1IO (m2)



Temperature Sensor
(i11)



Battery Holder (3x AAA batteries installed)

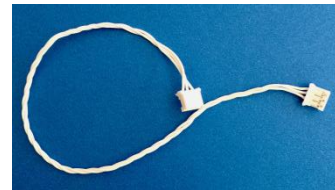

BOSON cable *2



Aluminum Foil



Blue Tack



Lamp

What You Do

1. Prepare BOSON modules.
Build an experimental circuit to realize the function of reading temperature.

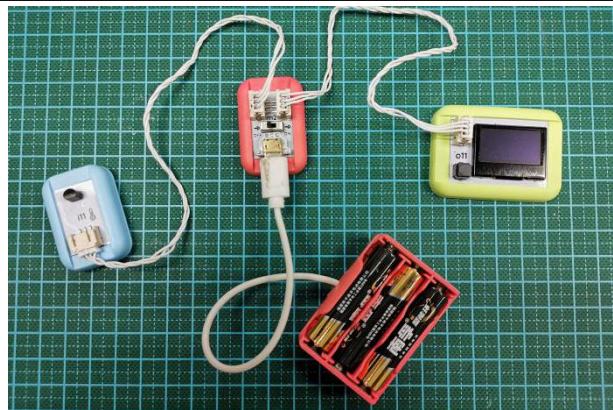

2. Prepare aluminum foil and double sided adhesive tape.
Cover the inner side of the paper board with the foil and make it as smooth as possible.
Fold the excess foil to the other side of the cardboard and fix it with double sided adhesive tape.



3. Prepare a pencil and blue tack. Use the pencil as support and fix the flip with blue tack.



4. Prepare blue tack. Tear one corner of the plastic wrap, fix the BOSON temperature sensor in the pizza box with blue tack, and then restore the wrap.



5. Prepare blue tack. Fix the BOSON display and other BOSON modules at the edge of the pizza box with blue tack. In order to quantify the efficiency of the solar oven, we need to check the temperature in the solar oven and the degree of melting of the chocolate at regular intervals and record them in the table below.



The table of temperature change of the solar oven:

Time	0min	10min	20min	30min	40min
Temperature					
Melting Degree of					

the Chocolate					
---------------	--	--	--	--	--

Test and Evaluate

On a shining day in the summer, at about 12 o'clock and 3 o'clock, put the solar oven under the sun. We can enjoy delicious chocolate sandwich biscuits after a while! If the weather is not so good, we can also use a warm-light lamp as the light source to continue the experiment.

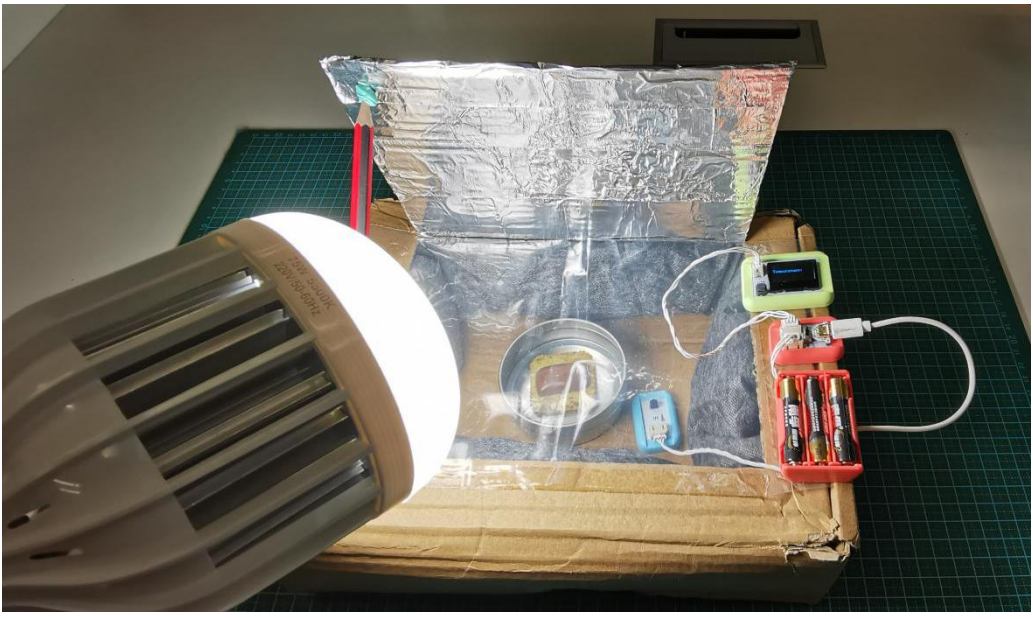

Note 1: If it is in a hot summer, the temperature of the solar oven may be very high. Remind students to use anti-scalding gloves to prevent burns.

Note 2: Chocolate will not melt until it is above 30 degrees. If it is in the cold winter, the room temperature is low and the temperature of the solar oven does not reach 30 degrees, the chocolate will not melt. In winter, we can change this lesson into "solar plant greenhouse". The goal is to use solar energy to create a warmer living environment for plants in

the cold winter. Please pay attention to the ventilation of the experimental device this time.

What Happened?

When the lights from the sun reaches the earth, they are reflected by the aluminum foil and pass through the plastic wrap, heating the air inside the pizza box, so the temperature in the pizza box will rise, just like a car gets hot in summer. The newspaper in the pizza box plays a role in insulating.

Compared to traditional ovens, solar ovens are a low-cost and eco-friendly technology. Although it takes a longer time to cook, it does work.



Explore Further

In this activity, we made a very simple solar oven, and we can also try adjusting many variables in the solar oven design to make it better. Such as changing the angle of the reflector baffle, or using color with better heat-absorbing ability in the oven to improve the efficiency of the solar oven.

Different colors have different heat absorption abilities. If a piece of black paper is put at the bottom of the oven, can the efficiency of the solar oven be improved? Let's continue to explore it!



Science Background

Which color absorbs the most heat?

When light hits on an object, three things happen: part of the light can be absorbed by the object, part of the light can be reflected by the object, and part of the light can continue to spread through the object.

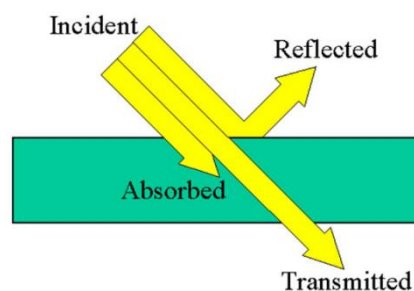

Different colors reflect and absorb light differently. Dark colors, especially black, will absorb light more, and the absorbed light will be converted into heat. Light colors reflect light more easily and absorb less light. This is why wearing a black shirt in summer feels hotter than

wearing a white one!

Conclusion

In this project, we made a solar oven using the pizza box, plastic wrap, and newspaper. With the knowledge of light reflection, we optimize the design of the oven. In further exploration, we have mentioned that the efficiency of the oven can be improved with the change of the angle of the reflector baffle and the choose of a better color in heat absorption.

The project is going to an end, please remove cables, and put all the BOSON modules back into the kit.

LESSON 9: Fridge Door-closing

Reminder

Introduction

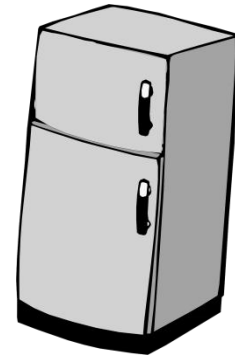

Standards

NGSS

4-PS3-2 Make observations to provide that energy can be transferred from one place to another via sound, light, heat and current.

4-PS3-4 Use scientific concepts to design, test, and improve equipment that can transform energy from one form to another.

Science - Grade 3-5

Overview

In these busy times it is now common to forget to close the fridge door. This lesson will lead students to explore how to make a fridge door-closing reminder, and determine the proper height the temperature sensor should be positioned at based on the principle of hot air rising and cold air falling.





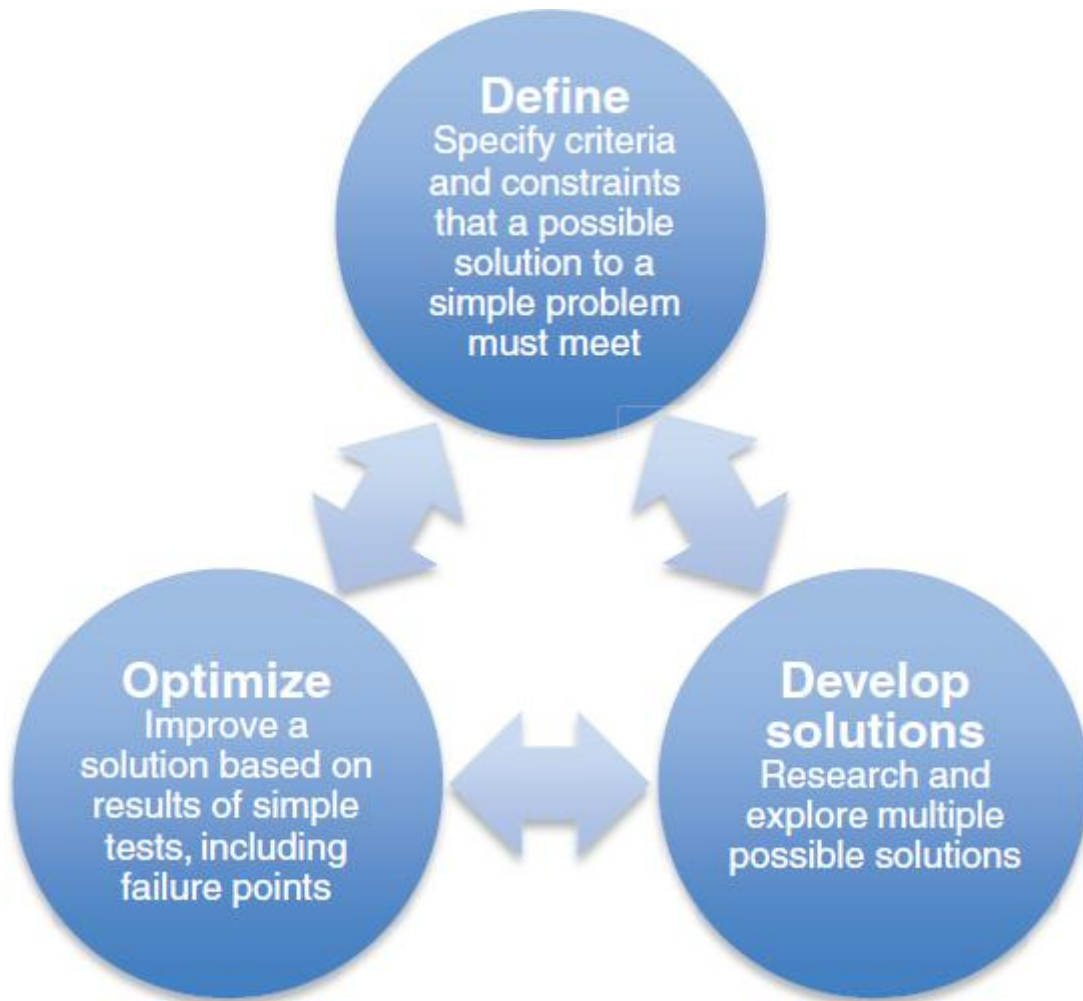



According to the NGSS standard engineering design requirement in 3-5 grades, the course is divided into 3 parts, they are respectively “DEFINE ENGINEERING PROBLEMS, DEVELOPING POSSIBLE SOLUTIONS, OPTIMIZING THE DESIGN SOLUTION” . Just like engineers, students will find problems, set goals, design plans, build and test models, optimize and improve models, and finally complete the engineering design task.

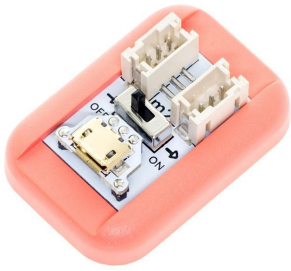



Materials

BOSON Module	Image	Function
Battery Holder (3x AAA batteries installed)		4.5V Power Supply

<p>MainBoard-1IO (m2)</p>	 <p>A small electronic module with a white PCB and a red plastic housing. It features a white M.2 connector on the left and several pins on the right. A small black component is visible on the board.</p>	<p>Provide power for other modules</p>
<p>Temperature Sensor (i11)</p>	 <p>A small electronic module with a white PCB and a light blue plastic housing. It features a white M.2 connector on the left and a black temperature sensor component on the right.</p>	<p>Measure the temperature</p>
<p>Buzzer Module(o5)</p>	 <p>A small electronic module with a white PCB and a light green plastic housing. It features a white M.2 connector on the left and a black buzzer component on the right. A circular label on the buzzer reads "REMOVE SURF L P L WASHINGS".</p>	<p>Make sound</p>
<p>Logic Module - NOT(f3)</p>	 <p>A small electronic module with a white PCB and a yellow plastic housing. It features two white M.2 connectors on the left and right. A small black component is visible on the board, with the label "f3" and "not" nearby.</p>	<p>When the input signal is "off" or "0", the module outputs "on" or "1".</p> <p>When the input signal is "on" or "1", the module outputs "off" or "0".</p>

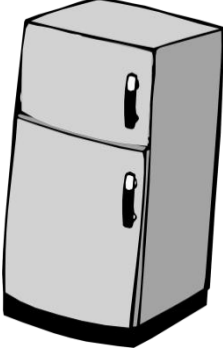
Threshold Module(f6)		Used as a threshold switch to change state when the input exceeds the threshold.
BOSON cable *4		Cooperate with 3-Pin fool-proof interface to connect other modules

Additional Materials	Image	Function
Refrigerator		The experimental object, used to verify and optimize the project.
Stopwatch		Record the time in the process of optimizing the design.

Activity 1 DEFINE ENGINEERING PROBLEMS

Find Problem

In the hot summer, when we open the refrigerator and take out the delicious ice cream, we leave with the door open. After a while, when we come to the refrigerator again, we will find the delicious ice cream melted. Oh, what a terrible experience!

Why not make a refrigerator door-closing reminder? This is a good idea, let' s do it!



Engineering Goals

Make a refrigerator door-closing reminder.

Activity 2 DEVELOPING POSSIBLE SOLUTIONS

After determining the engineering goals, let us follow the process of "Brainstorming-Drawing Prototype Diagram-What You Need-What You

Do-Test and Evaluate” to complete the making of the refrigerator door-closing reminder.

Brainstorm

Let’ s first brainstorm how to build a refrigerator-closing reminder. In the process, try drawing a prototype of the reminder.

Question	Reference Answer
1. What is the function of the refrigerator door-closing reminder?	Remind us to close the refrigerator when we forget.
2. How can we make a refrigerator-closing reminder?	Observe the difference when opening or closing the refrigerator door. Use the BOSON module to build an intelligent device to detect whether the refrigerator door is closed.
3. What is the difference between opening or closing the refrigerator door? How to detect it?	Difference 1: When the refrigerator door is opened, the cold air will run out, which will lower the temperature around the refrigerator. Using BOSON temperature sensor to detect the

temperature changes, you can determine whether the refrigerator door is open.



Difference 2: When the refrigerator door is opened, the light in the refrigerator will turn on. Use BOSON light sensor to detect the light changes, then you can determine whether the refrigerator door is open.



4. How to send a reminder?

Remind us with sound so as to attract attention. The BOSON buzzer is a sounding device that can send an alarm to remind us.



5. Which method is better?

Let's analyze the usage scenarios of the two methods first.

When the temperature sensor is used and the refrigerator door is opened for a long time, the surrounding temperature will decrease, which will make the reminder device send a prompt after the refrigerator door is forgotten to be closed for a while.

When using light sensor, every time the refrigerator is turned on, the light is on, so every time the refrigerator door is opened, a reminder will be sent until the refrigerator door is closed.

Then, let's analyze the usage time.

When using the temperature



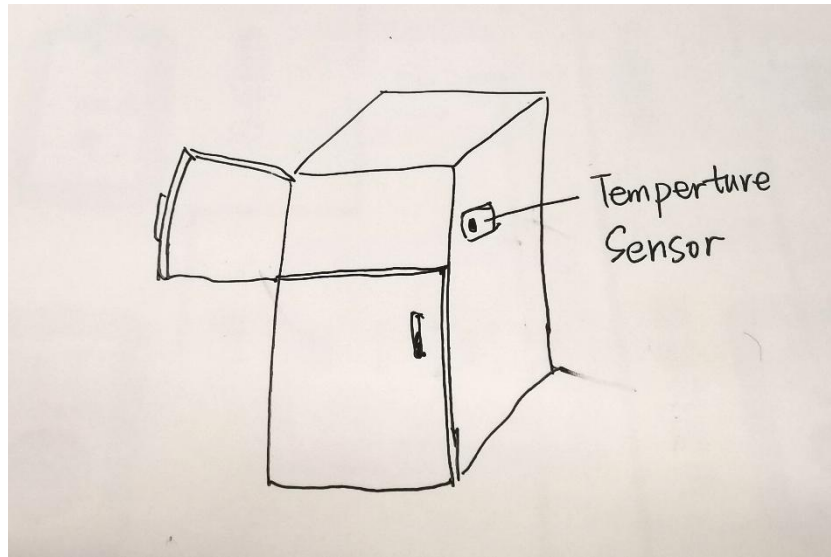

	<p>sensor, if it is in the hot summer, opening the refrigerator door will significantly reduce the surrounding temperature. If it is a cold winter, the temperature will not change much.</p> <p>When using the light sensors, there is no need to consider seasonal changes.</p> <p>After a comprehensive analysis, we learn that it is better to use a temperature sensor in summer and a light sensor in winter.</p> <p>In the following project, we take the temperature sensor in summer as an example.</p>
--	--

Draw Prototype Diagram

Through brainstorming, we have initially understood the function and structure of the refrigerator door-closing reminder. Try drawing a prototype diagram. In the production process, the prototype diagram will be an important reference.

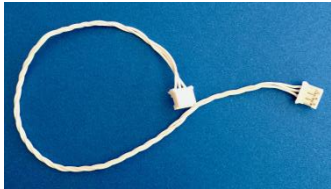

What You Need

 <p>MainBoard-1IO (m2)</p>	 <p>Buzzer Module(o5)</p>	 <p>Threshold Module(f6)</p>
 <p>Logic Module - NOT(f3)</p>	 <p>Temperature Sensor (i11)</p>	 <p>BOSON cable *4</p>



Battery Holder (3x AAA batteries installed)

What You Do

1. Prepare the BOSON module.

According to the picture on the right, build an experimental circuit to realize the function of controlling the buzzer with temperature.

2. Turn the switch of the main control board to ON and observe whether the buzzer sounds.

In this circuit, the buzzer basically does not make a sound. At this time, we can add a threshold module to set the critical temperature value

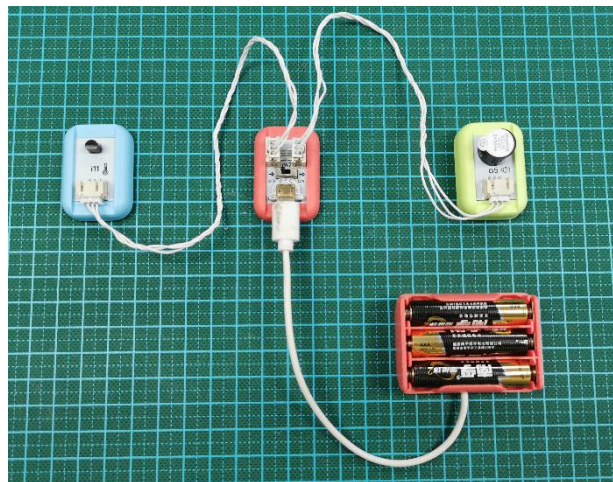

to make a sound.

3. Add the Threshold Module and complete the circuit connection according to the figure on the right.

There are "+" and "-" signs next to the blue knob of the Threshold Module, indicating the size of the set threshold.

Turn the knob arrow to "-" to decrease the set critical value.

When the critical value is less than the feedback value from the current temperature sensor, the buzzer will buzz.

On the contrary, turning the knob to "+" will increase the critical value, and the buzzer will no longer sound.

Note: Connect the Threshold Module in the direction of the arrow.

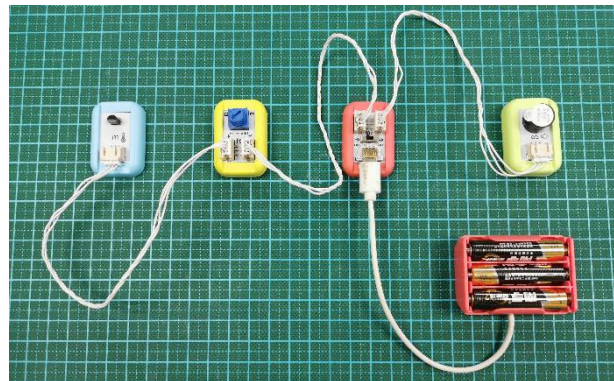

4. Turn the blue knob of the Threshold Module until the buzzer just doesn't make sound. At this time, hold the black detector of the temperature sensor to raise the temperature, and it can be found that the buzzer immediately emits a sound.

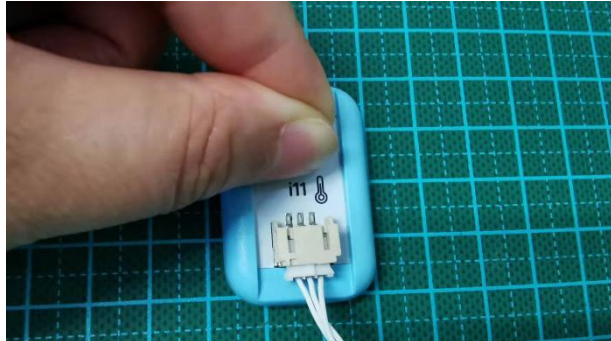

5. In the refrigerator door closing reminder, we should let the buzzer sound when the temperature drops. So, add Logic Module-NOT and complete the circuit connection according to the figure on the right.

Note: Connect Logic Module-NOT in the direction of the arrow.

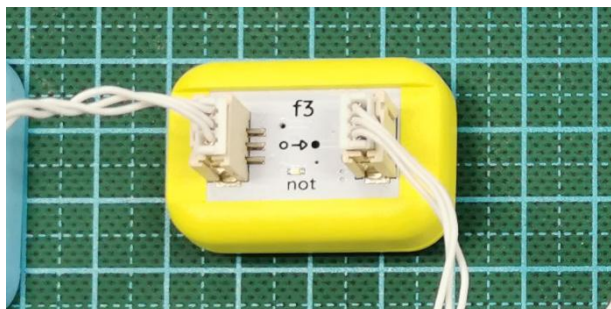
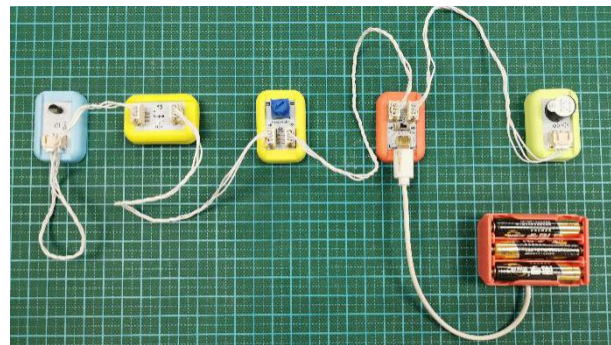

6. Open the refrigerator door for a period of time, put the device near the refrigerator, and fix it on the refrigerator by magnetic attraction.

Turn the blue knob on the Threshold Module to set a temperature threshold. When the temperature is lower than this value, the buzzer will buzz to alert people.



Test and evaluate

After the above steps, a simple refrigerator door-closing reminder is completed! Now try it to test its performance.

When fixing the temperature sensor, will the experiment result be different when the sensor is placed at different heights? Which height will give the best result? Try proposing an optimization plan to improve the response speed of the reminder.

Activity 3 OPTIMIZING THE DESIGN SOLUTION

Let us continue the process of “Brainstorming-Drawing Prototype Diagram -What You Need-What You Do-Test and Evaluate” to carry out optimization and iteration of fridge door-closing reminder.

Brainstorm

Question	Reference Answer
1. How to improve the response speed of the reminder?	If the temperature change can be detected faster, the response speed can be improved.
2. After opening the refrigerator door, will the temperature decrease at the same speed at different heights of the refrigerator door? How to detect it?	We guess that the temperature change speed is different at a different height. We can set up a comparative experiment to find out the height where the temperature changes fastest.

What You Do

Through brainstorming, we guessed that after opening the refrigerator door, the temperature changes at different heights of the refrigerator. Fixing the temperature sensor at the height with the fastest temperature change can increase the response speed of the reminder. Is it true? Let's verify it together!

1. As shown in the picture on the right, select 3 positions at different heights of the refrigerator door.

First, fix the temperature sensor at position 1, and take the time when the refrigerator door is opened as the starting time. Use a stopwatch to record the response time of the buzzer sound, and record it in the table below.

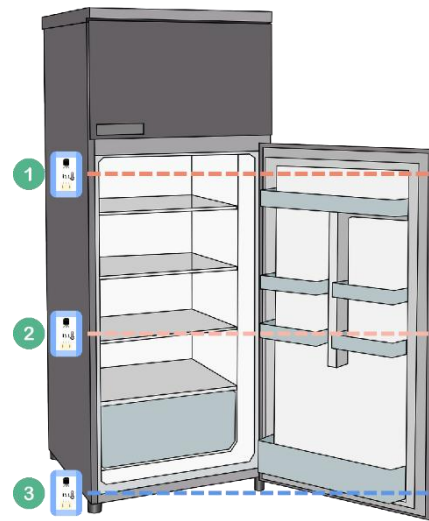

2. Place the temperature sensor at position 2 and position 3, repeat the above operation, and record the data in the table below.

The table of the response time of the reminder:

Position	Response time (unit: second)
1	
2	
3	

Note: In the actual experiment, you can allow 3 groups of students to conduct experiments at different positions of the refrigerator door at the same time, and finally gather the data together to save experiment time.

Test and evaluate

The referable data is as follows:

Position	Response time (unit: second)
1	501
2	262
3	105

Through 3 sets of comparative experiments, we can conclude that the temperature at the bottom of the refrigerator changes fastest, which is the best position to fix the temperature sensor.

What happened?

In the hot summer, the air temperature in the refrigerator is low, and the air temperature in the environment is high. When we open the refrigerator door, due to the temperature difference, the cold air and the hot air will transfer heat through heat convection. So, the air near the refrigerator door will cool down.

Just like a hot air balloon will rise, near the refrigerator, the hot air will rise and the cold air will drop, so the lower part near the refrigerator will be colder.



Further Exploration

In this activity, we made a very simple refrigerator door -closing reminder, but it can only be used in summer. Think about it, if in winter, is there a better solution? Let' s continue to explore it!

Science Background

Why do hot air rise and cold air fall?

Air is made up of many invisible molecules.

In hot air, the molecules move fast and collide with each other, increasing the space around them, so the hot air will expand. After expansion, there are fewer molecules and lighter weight per unit volume, so the hot air will rise.

In cold air, the molecules move slow, and there are more molecules and heavier weight per unit volume, so the cold air will drop.

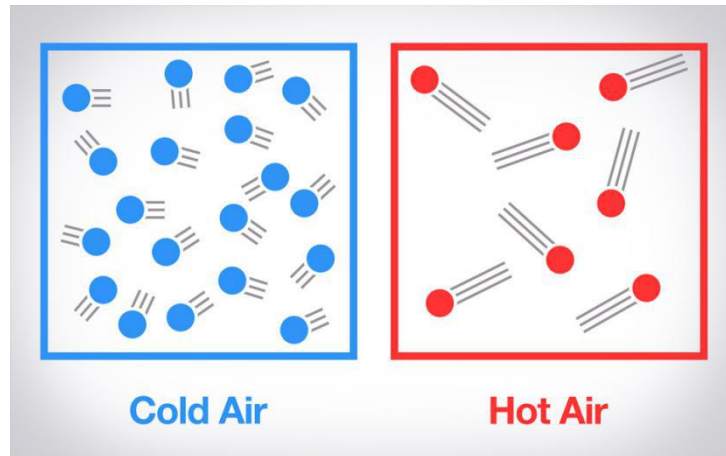

Hot air balloon and Kongming lantern

Hot air balloons in Turkey and Kongming lanterns in China both use the principle of hot air rising.



Conclusion

In this project, we made a refrigerator door-closing reminder, and optimized the design of the reminder by using the knowledge of hot air rising and cold air falling.

The project is going to an end, please remove cables, and put all the BOSON modules back into the original positions of the kit.

LESSON 10: Automatic Plants Fill Light



Introduction

Standards

NGSS

5-PS3-1 Use models to describe that the energy in animals' food (used for body repair, growth, movement, and to maintain body warmth) was once from the sun.

3-LS3-2 Use evidence to support the explanation that traits can be influenced by the environment.

Science - Grade 3-5

Overview

The shortage of sunlight often slows the plants growth down significantly. In this lesson, students will discuss how to solve the problem of lack of sunlight in a greenhouse in winter or rainy days, and try making an automatic light fill device to help plants grow better!





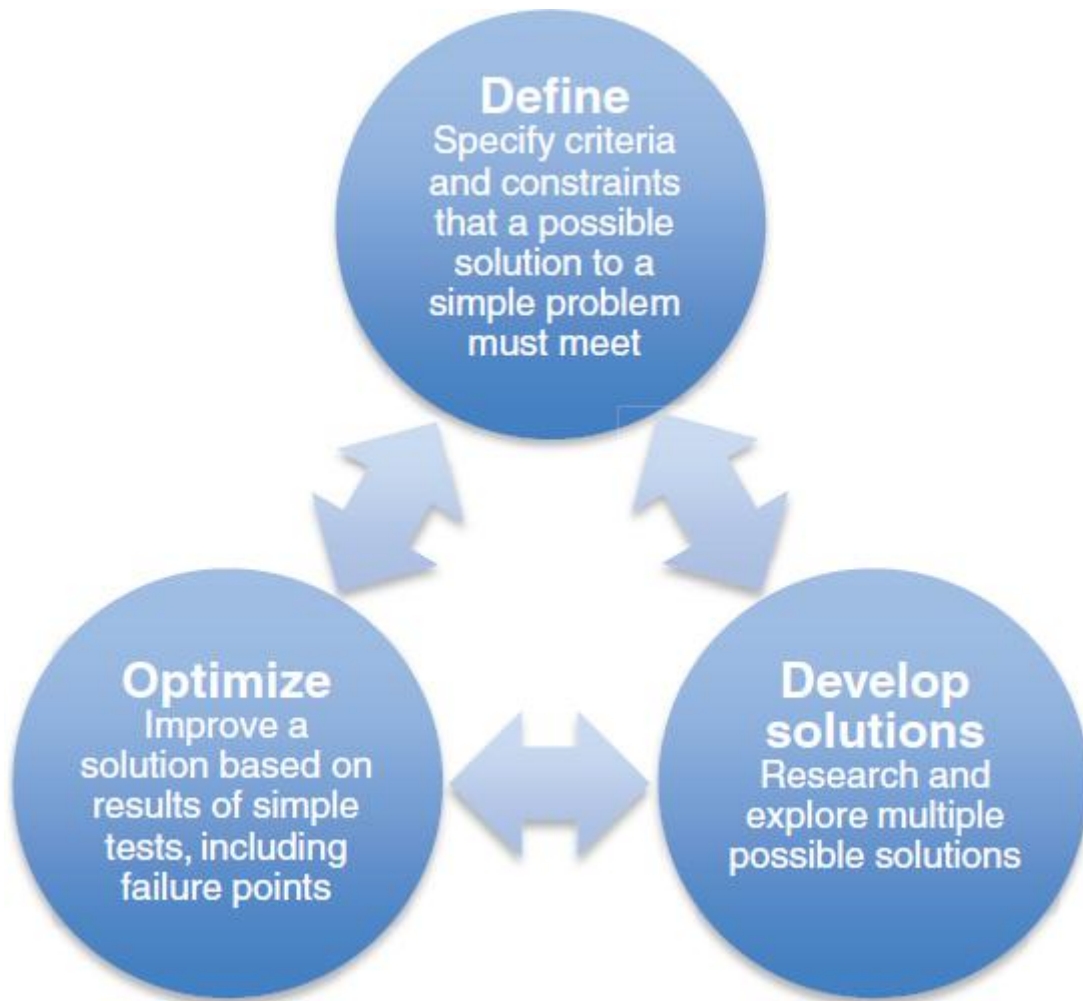

According to the NGSS standard engineering design requirement in 3-5 grades, the course is divided into 3 parts, they are respectively “DEFINE ENGINEERING PROBLEMS, DEVELOPING POSSIBLE SOLUTIONS, OPTIMIZING THE DESIGN SOLUTION” . Just like engineers, students will find problems, set goals, design plans, build and test models, optimize and improve models, and finally complete the engineering design task.



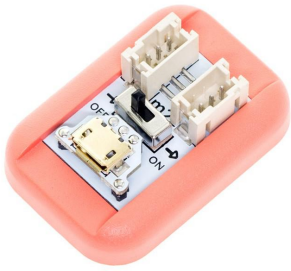

Materials

BOSON Module	Image	Function
Battery Holder (3x AAA batteries installed)		4.5V Power Supply

MainBoard-1IO (m2)		Provide power for other modules
Light Sensor (i4)		Measure the intensity of ambient light
Yellow Push Button (i2y)		Switch button
Ultra-bright LED(o1)		The simplest white light-emitting module. Brightness can be adjusted.
Logic Module - OR(f2)		This module can process the two input signals and combine them into one signal.

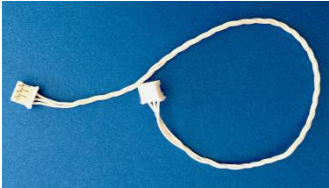
		<p>The input and output mechanism are as follows:</p> <p>When the input signal at one or both ends is "on" or "1", the module outputs "on";</p> <p>If and only when the input signal at both ends is "off" or "0", the module outputs "off".</p>
<p>Logic Module - NOT(f3)</p>		<p>When the input signal is "off" or "0", the module outputs "on" or "1".</p> <p>When the input signal is "on" or "1", the module outputs "off" or "0".</p>

Threshold Module(f6)		Used as a threshold switch to change state when the input exceeds the threshold.
BOSON cable *6		Cooperate with 3-Pin fool-proof interface to connect other modules

Additional Materials	Image	Function
Potted plants		The experimental object.
LEGO blocks		Used to build a bracket to fix the sensor

Activity 1 DEFINE ENGINEERING PROBLEMS

Find Problem

In cold winter, fresh fruits and vegetables cannot grow naturally, and often need to be planted in warm greenhouses. However, the sunshine time in winter is short and there are often cloudy days, plants are hard to grow in such conditions. How to solve this problem? Let's find out a solution together!



In the previous project, we talked about that the point of direct sunlight will change in winter. This is the time of the year when the sun is slanting the strongest, so the light is very weak and the sunshine period is short. In order to solve the problem of lack of light in greenhouse, we can design a device that automatically supplies light for plants, let's try it together!

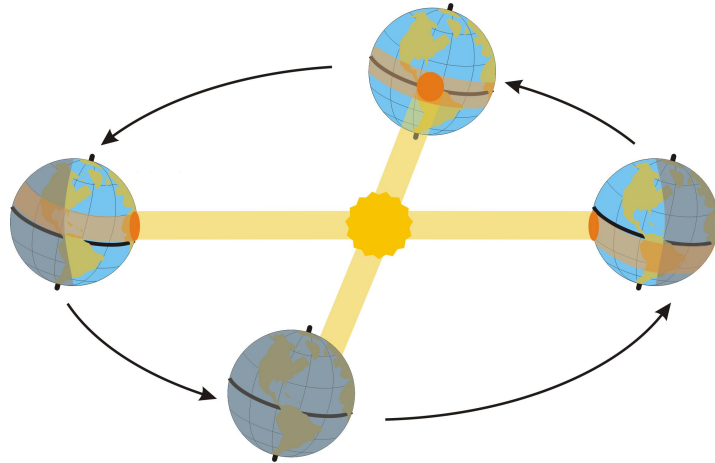

Engineering Goals

Make an automatic light-supplying device for plants.

Activity 2 DEVELOPING POSSIBLE SOLUTIONS

After determining the engineering goals, let us follow the process of “Brainstorming-Drawing Prototype Diagram-What You Need-What You Do-Test and Evaluate” to develop a solution and complete the building of auto light-supplying device.

Brainstorm

Let’ s first brainstorm how to build an automatic light-supplying device. In the process, try drawing a prototype of the automatic light-supplying device.

Question	Reference Answer
1. What is the function of the automatic light-supplying device?	When the sunlight is weak, it will automatically supply light for the

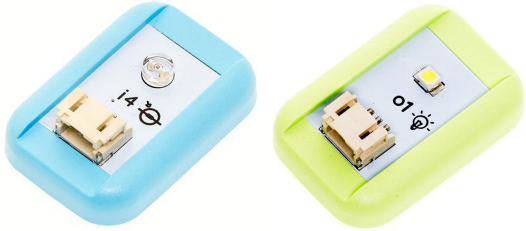
	plants.
2. How to determine whether the sunlight is sufficient? How to achieve light supplying?	<p>Use the light sensor to judge the intensity of the light. When the light is weak, use the fill-in lamp to supply plants with light.</p> 
3. How to make the automatic light-supplying device	<p>To build the circuit with BOSON module, a bracket is also needed to fix the BOSON module.</p> <p>Place the device next to the plants, the light sensor is facing the sun to facilitate detection of light changes, and the fill-in lamp is facing the plants to facilitate the light supplement.</p>



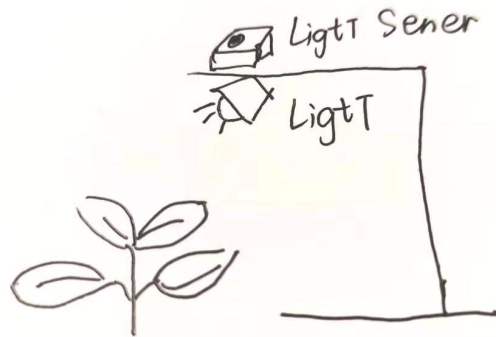

Raw Prototype Diagram

In the brainstorming, we have initially understood the function and structure of the automatic light-supplying device. Try drawing a

prototype diagram. In the production process, the prototype diagram will be an important reference.

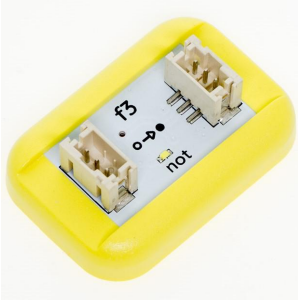

What You Need

 <p>MainBoard-1IO (m2)</p>	 <p>Light Sensor (i4)</p>	 <p>Ultra-Bright LED(o1)</p>
 <p>Logic Module - NOT(f3)</p>	 <p>Threshold Module(f6)</p>	 <p>Battery Holder (3x AAA batteries installed)</p>

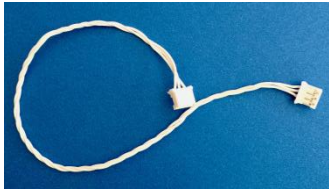

BOSON cable *4



Potted Plants



LEGO Blocks

What You Do

1. Prepare the BOSON module. According to the picture on the right, build an experimental circuit to realize the function of turning on the light when the light is weak.

Note: Connect the threshold module and logic NOT module in the direction of the arrow on the module.

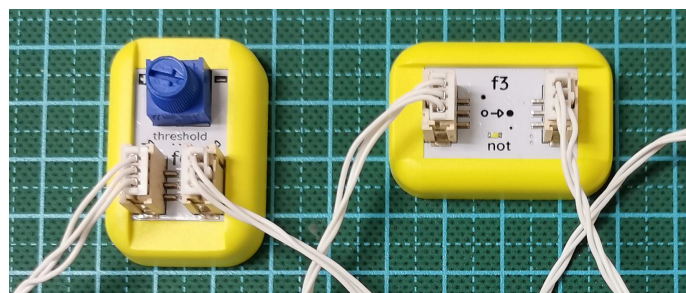
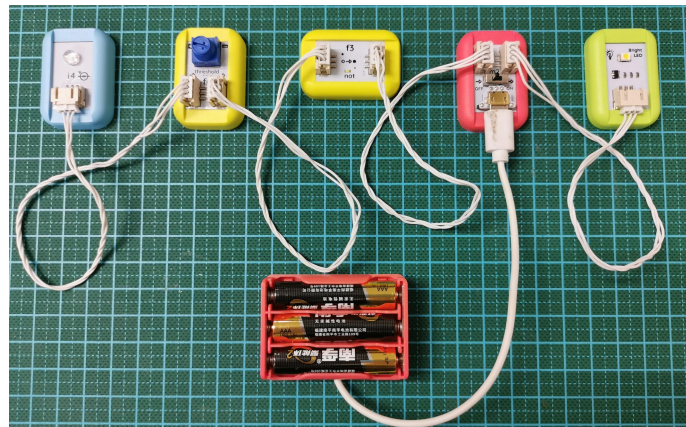

2. Turn the switch of the main control board to ON, and adjust the blue knob of the threshold module to make the LED light just change from on to off.

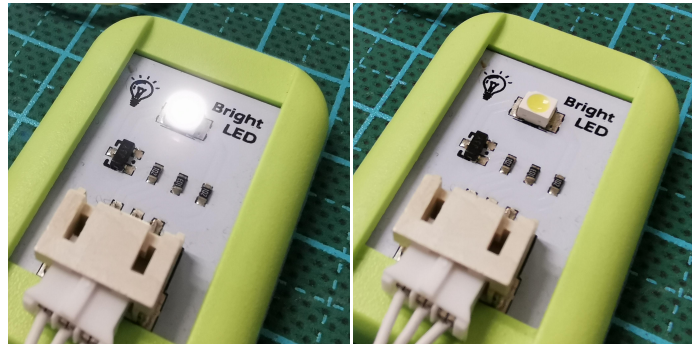

3. At this time, cover the transparent probe of the light sensor with your hand, you can find that the LED light becomes brighter when the ambient light gets darker.

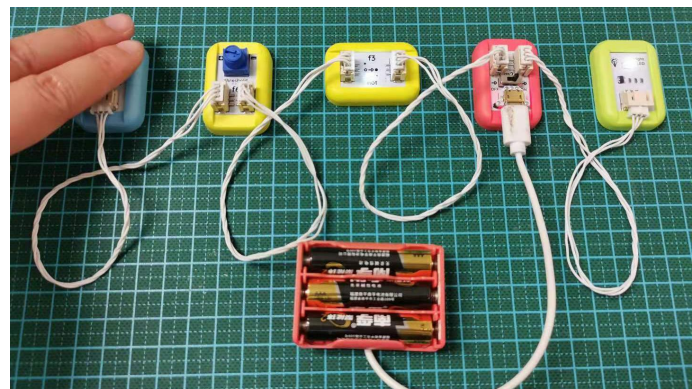

4. Prepare LEGO blocks and blue tack. Build a LEGO bracket to fix the sensor and LED lights.

Note: Fix BOSON module to the LEGO base, and fix the module on the inclined surface with blue tack.

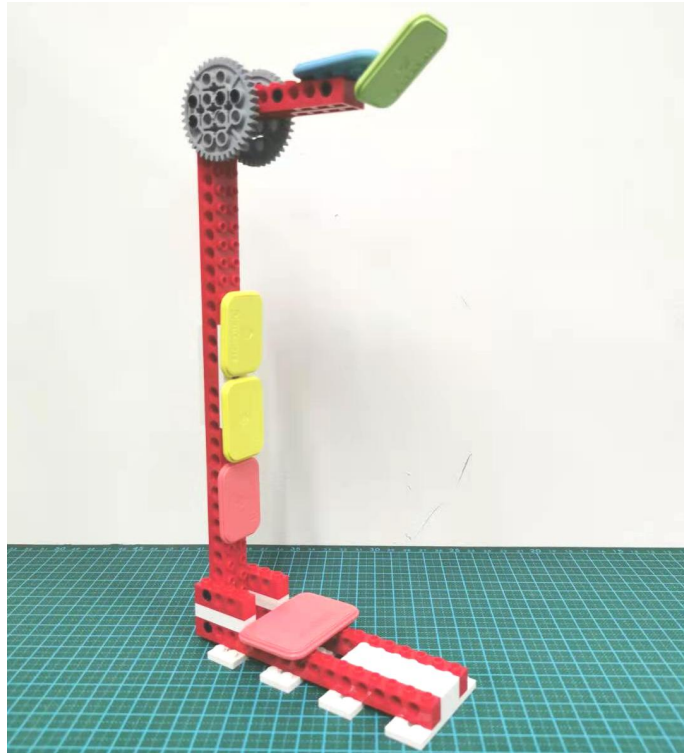

5. Fix the BOSON module on the Lego bracket. The light sensor is fixed on the top of the bracket, and the transparent probe of the sensor is upward.

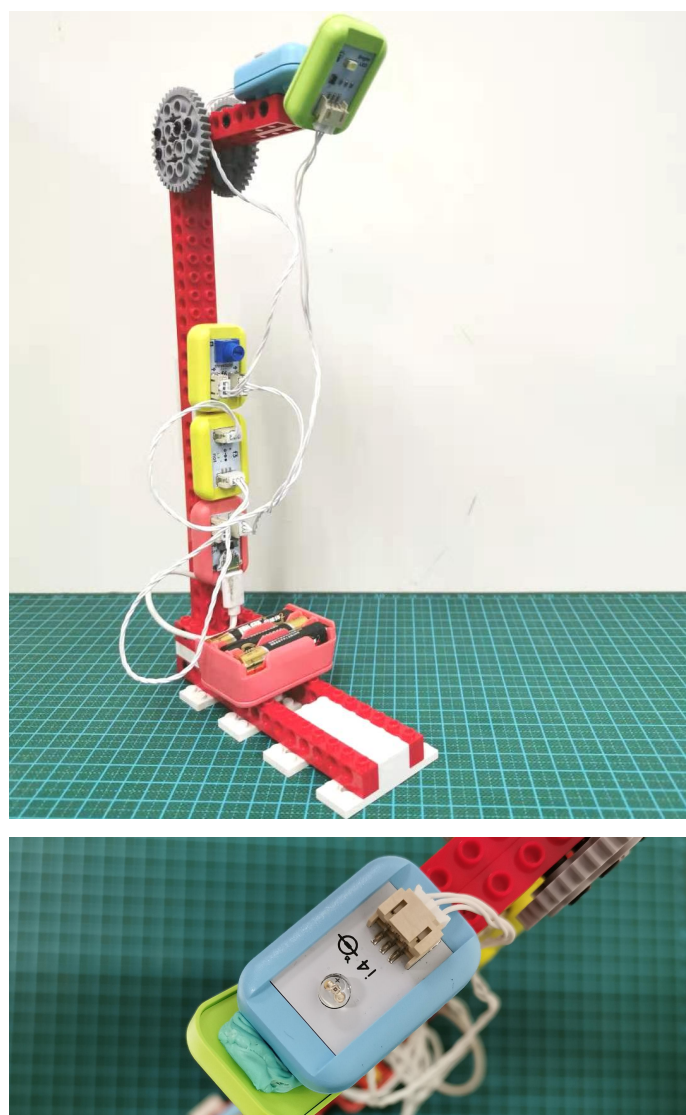

Test and evaluate

After the above steps, a simple automatic light-supplying device is done!
Put it next to the plants, when the light sensor detects that the light is weak, it will automatically turn on the LED light to supply light.

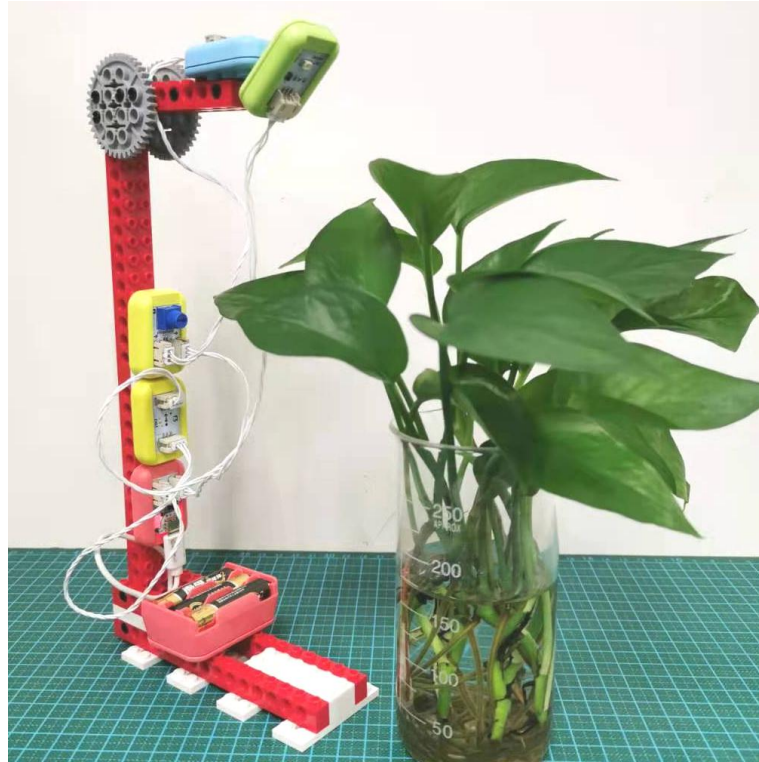

Do you think there is still something to be optimized for the device? Can the supplement be achieved manually? For example, by pressing a switch, you can manually turn on the lamp. Try to come up with an optimization plan.

Activity 3 OPTIMIZING THE DESIGN SOLUTION

Let us continue the process of “Brainstorming-Drawing Prototype Diagram -What You Need-What You Do-Test and Evaluate” to carry out optimization and iteration of light-fill device and add manual controlling function.

Brainstorm

Question	Reference Answer
----------	------------------

1. How to manually control the device?

A button can be added. Press the button to turn on the fill-in lamp.



2. How to realize manual control and automatic control at the same time?

The BOSON logic OR module can process and combine the two input signals, and output into one signal. As long as any one of the two input signals is satisfied, it will trigger the module to output signal.

Based on the original experimental circuit, adding logic OR modules to let the device work manually and automatically.

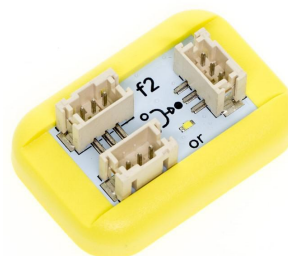

What You Need

Based on the above activities, add the following BOSON modules and other materials.

 <p>Yellow Push Button (i2y)</p>	 <p>Logic Module - OR(f2)</p>	 <p>BOSON cable *2</p>
---	--	---

What You Do

1. Modify the circuit according to the figure on the right

Note: Connect the circuit in the direction of the arrow on the logic OR module.

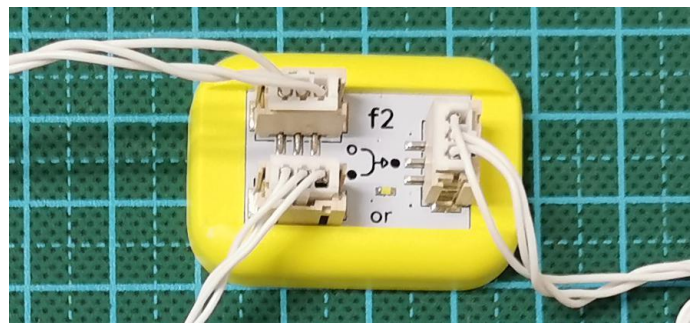
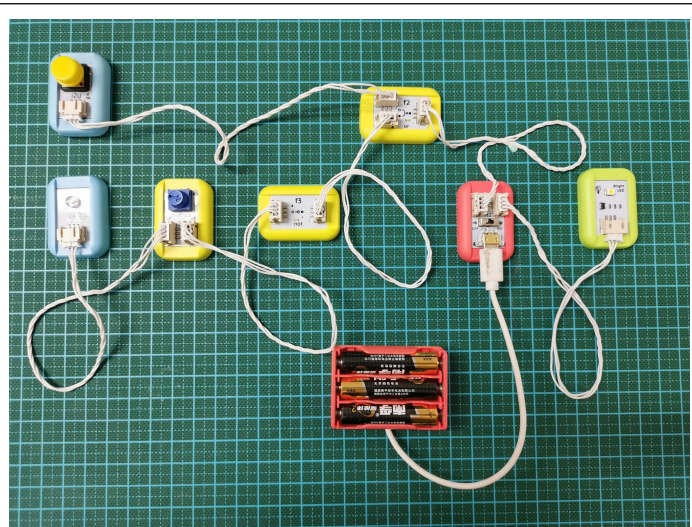

2. Turn the switch of the main control board to ON. Press the button, the LED light turns on, release the button, the LED goes out.

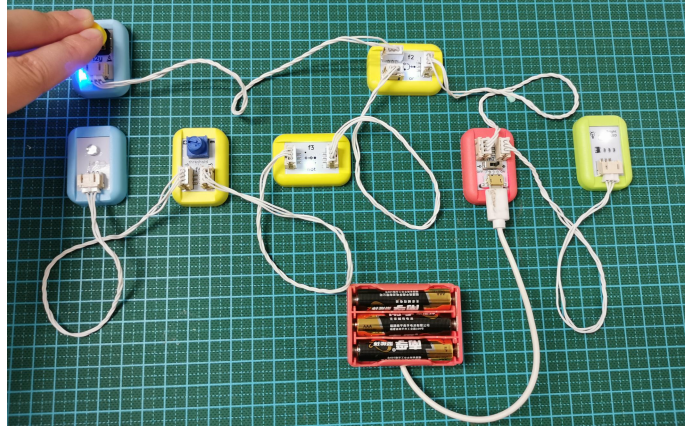

3. Cover the transparent probe of the light sensor with your hand, the LED light turns on, remove your hand, and the LED goes out.

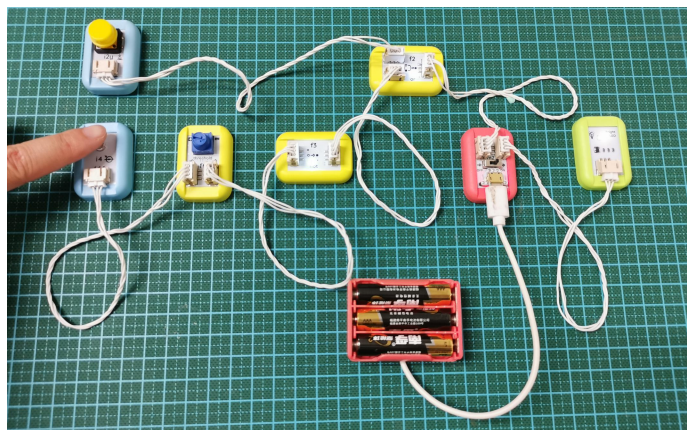

4. Finally, fix all BOSON modules on the Lego bracket to complete the production of the device.



Test and evaluate

The optimized device realizes automatic and manual control at the same time. When the light sensor detects that the natural light becomes weak,

it will automatically turn on the LED light. When we press the button, we can also manually light up the LED light.

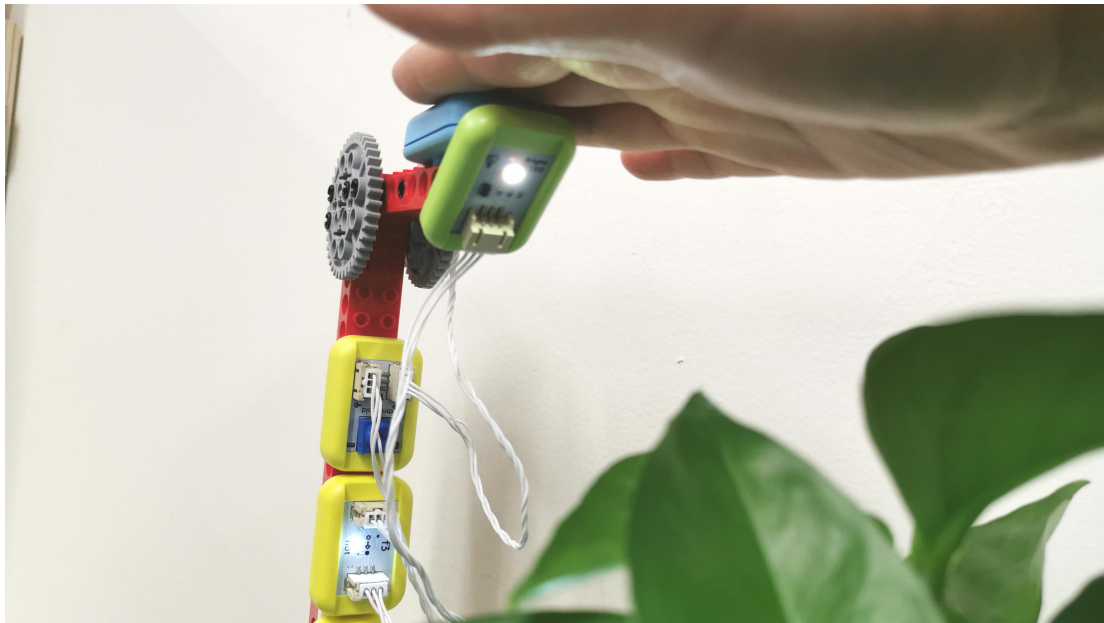

Further Development

In this activity, we made a very simple automatic light-supplying device for plants, and we can also continue to optimize the design of the device. For example, what color of light helps plants grow better? Let' s continue to explore it!



Science Background

Why do plants need light?

As the saying goes, "All living things depend on the sun for their growth" . Most of the energy on the earth comes from the sun. Through its photosynthesis, plants can convert solar energy into chemical energy, which is stored in the formed organic compounds.

Photosynthesis refers to the process by which plants absorb energy from sunlight and convert carbon dioxide and water into oxygen and their chemical energy. In photosynthesis, plants first absorb the energy of the sun, and then use this energy to decompose water molecules into hydrogen and oxygen, and finally oxygen is released into the atmosphere. The hydrogen and carbon dioxide combine to form glucose or plant food, which is stored in leaves, roots or fruits.

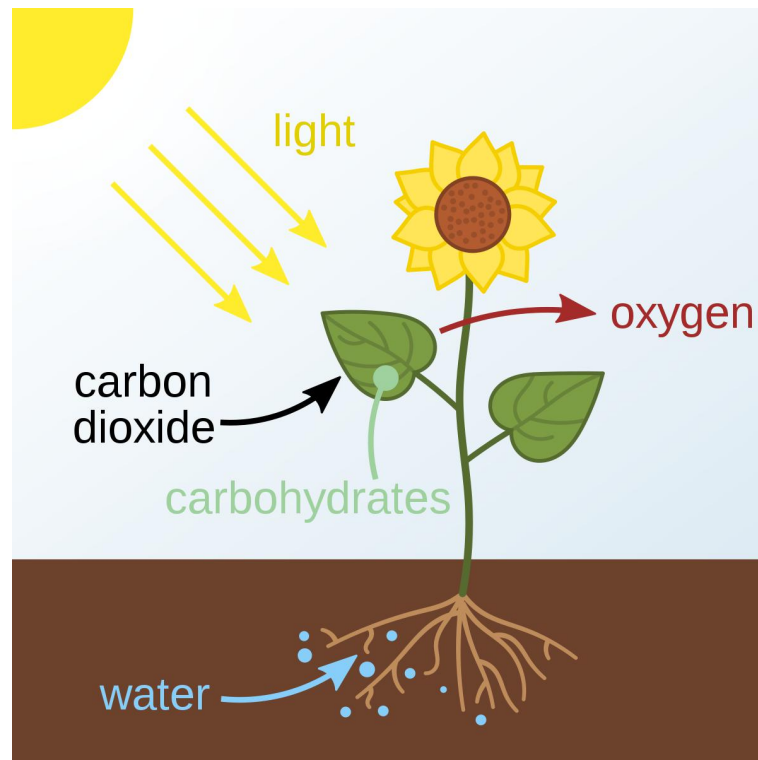

The energy produced through photosynthesis not only meets the needs of plants for their growth, but also provides a source of food for humans and animals. In this way, plants are like a giant energy conversion station, converting solar energy into energy that can be used by humans and animals.

What color of light do plants like?

Green plants have the strongest absorption of red light and blue-purple light and can perform photosynthesis best, so plants prefer red and blue-purple light. This is why the fill-in lamps on the market are generally red light and blue-purple light.



Conclusion

In this project, we made an automatic light-supplying device for plants, and solved the problem of lack of light for plants in winter or rainy days. In the further development, we also mentioned the effect of light color on plant growth. Choosing an appropriate color helps optimize the design of the device.

The project is going to an end, please remove cables, and put all the BOSON modules back into the original positions of the kit.

LESSON 11: Automatic Watering



Introduction

Standards

NGSS

5-LS1-1 Demonstrate that plants get the nutrients they need for growth mainly from water and air.

Science - Grade 3-5

Overview

This lesson will begin with the question “Why towels can absorb water” to lead students to discuss and get to know the capillarity action of water. They will be asked to make an automatic watering device based on the capillarity action principle, and explore how to improve the watering efficiency by enhancing the capillarity or reducing water evaporation.

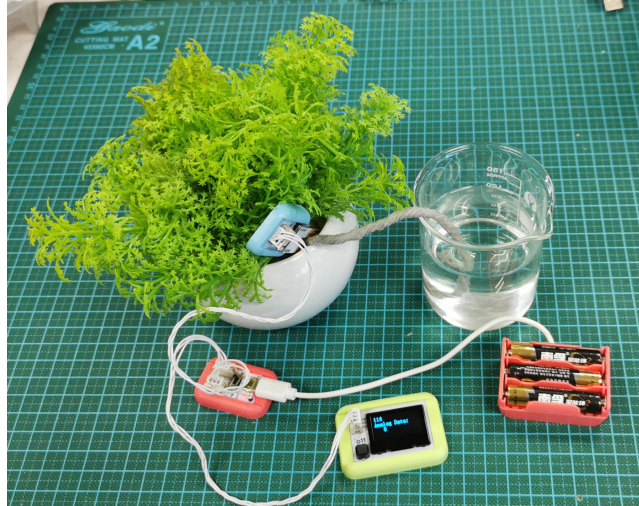

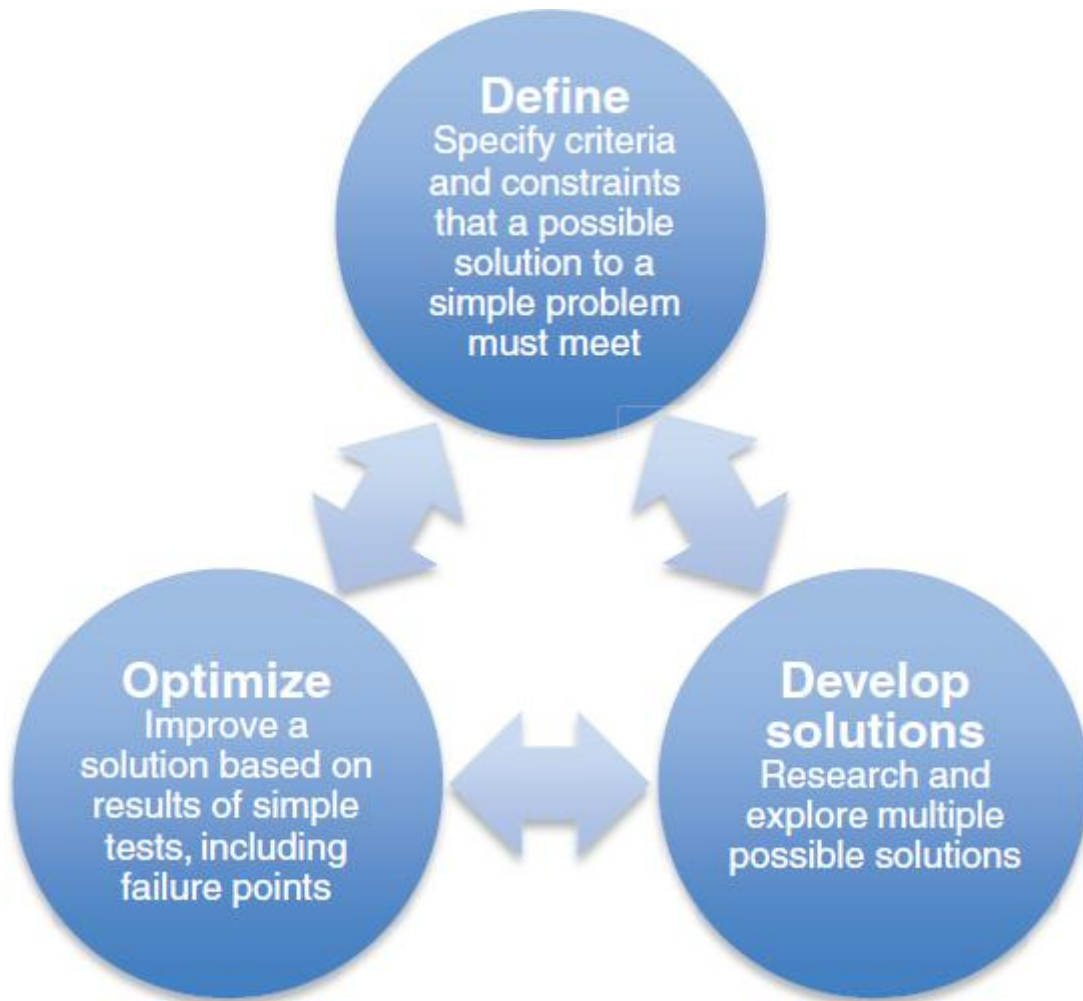

According to the NGSS standard engineering design requirement in 3-5 grades, the course is divided into 3 parts, they are respectively “DEFINE ENGINEERING PROBLEMS, DEVELOPING POSSIBLE SOLUTIONS, OPTIMIZING THE DESIGN SOLUTION” . Just like engineers, students will find problems, set goals, design plans, build and test models, optimize and improve models, and finally complete the engineering design task.



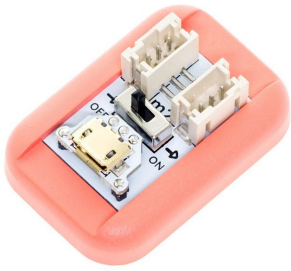

Materials

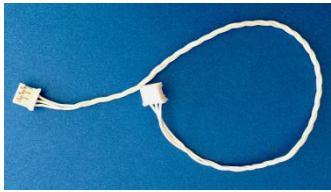
BOSON Module	Image	Function
Battery Holder (3x AAA batteries installed)		4.5V Power Supply

MainBoard-1IO (m2)		Provide power for other modules
Soil Moisture (i16)		Measure the value of soil moisture.
Display Module(o11)		Provide visible effect for users to check experimental results
BOSON cable *2		Cooperate with 3-Pin fool-proofing connector to connect other modules

Additional Materials	Image	Function
----------------------	-------	----------

Potted Plants		The experimental object
Cotton Rope		Used to make the automatic watering device
Breaker and Water		Used to provide water

Activity 1 DEFINE ENGINEERING PROBLEMS

Find Problems

We always grow flowers at home, but when we travel, there is a problem that the flowers will be unattended, and even wither because of lacking water.

Can we design an engineering device to realize the function of automatic watering?



Engineering Goals

Make an automatic watering device.



Activity 2 DEVELOPING POSSIBLE SOLUTIONS

After determining the engineering goals, let us follow the process of “Brainstorming-Drawing Prototype Diagram-What You Need-What You Do-Test and Evaluate” to develop a solution and complete the structure of the automatic watering device.

Brainstorm

Let’ s first brainstorm how to build an automatic watering device. In the process, try to draw a prototype of the automatic watering device.

Question	Reference Answer
1. How to water plants automatically?	We know that towels can absorb water. If you put one end of the towel in the water and the other end in the flower pot, then the plants can be watered

	<p>automatically.</p> 
<p>2. What else can absorb water?</p>	<p>In addition to towels, there are also loose and porous objects such as tissues, sponges, and cotton ropes.</p> 
<p>3. Which one is better to make the automatic watering device? Towel, tissue, sponge, or cotton rope?</p>	<p>Different objects are with different defects. For example, tissues are easy to spoil when exposed to water, towels are too big, and sponges are hard. After comprehensive consideration, we choose cotton rope to make the automatic watering device.</p>
<p>4. Can we observe the efficiency of watering?</p>	<p>Add BOSON soil moisture sensor to observe the efficiency of watering by detecting changes in soil moisture.</p>

Draw Prototype Diagram

In the brainstorming, we have initially understood the function and structure of the automatic watering device. Try drawing a prototype diagram. In the production process, the prototype diagram will be an important reference.

What You Need

A small electronic display module with a blue screen and a green plastic housing, labeled 'o11'.	A small electronic board with a red plastic housing, labeled 'm2', featuring various connectors and components.	A soil moisture sensor with a blue plastic housing and two yellow probes, labeled 'i16'.
Display Module(o11)	MainBoard-1IO (m2)	Soil Moisture (i16)
A red plastic battery holder with a white USB cable attached, containing three AAA batteries.		A white cable with a USB connector on one end and a different connector on the other, set against a blue background.
Battery Holder (3x AAA batteries installed)		BOSON cable *2
A 3D illustration of a green leafy plant in a grey geometric pot.	A coil of thick, white cotton rope.	A glass beaker containing water and a small white electronic component, sitting on a green grid mat.
Potted Plants	Cotton Rope	Breaker and Water

What You Do

1. Prepare BOSON modules.
According to the picture on the right, build an experimental circuit to realize the function of measuring the soil moisture.

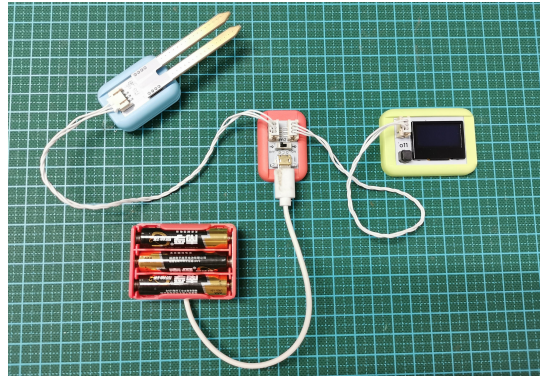

2. Prepare a potted plant and a cotton rope, and insert one end of the cotton rope into the soil of the potted plant.

3. Prepare a breaker of water and put the other end of the cotton rope into the water.

4. Insert the soil moisture sensor into the soil near the cotton rope, observe the change of soil moisture on the display screen, and record it in the table below.

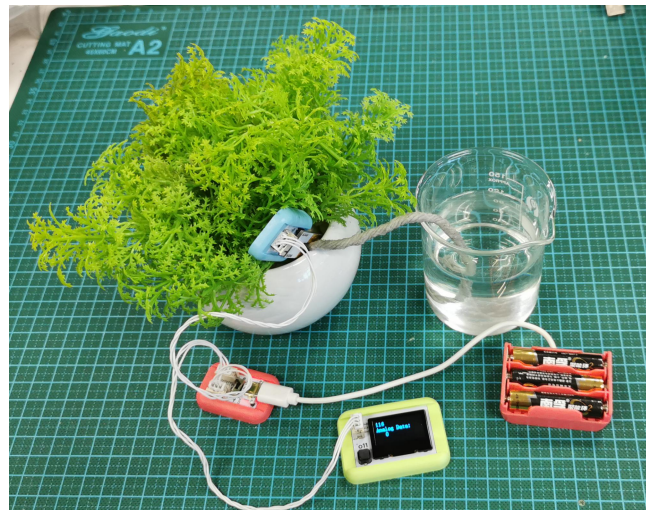

Soil moisture change table:

Time	1min	4min	7min	10min
Moisture				

Test and evaluate

Through the above steps, a simple automatic watering device is completed! When we touch the cotton rope with our hands, we will find that the cotton rope becomes wet, because it sucks up the water in the breaker, and the water will follow it to the soil, which realizes the automatic watering function.

Observe and compare the changes in soil moisture. Is the efficiency of the watering device of each group of students the same? Think about it, do you think there is still room for improving the device? How to improve the efficiency of watering? Try proposing an optimization plan to improve the watering efficiency.

Activity 3 OPTIMIZING THE DESIGN SOLUTION

Brainstorm

Question	Reference Answer
1. How to water plants faster?	We know that one cotton rope can water the plants with a small amount of water. If you use many ropes to water the plants at the

	same time, or use a very thick one, you can speed up the watering.
2. Is there still room for improving the automatic watering device?	Water is easy to evaporate. When the damp cotton rope is exposed to the air, the amount of evaporation is very large. We can find ways to reduce evaporation. For example, put the cotton rope in straw to reduce the contact between the rope and the air, so that the evaporation of water can be reduced.

What You Do

Based on the brainstorm, select an optimization plan.

Use BOSON soil moisture sensor to observe the changes of soil moisture and record them in the table below.

Optimized soil moisture change table:

Time	1min	4min	7min	10min
Moisture				

Test and evaluate

Draw the table of activity 1 and activity 2 onto one line chart and observe whether the watering efficiency is improved.

What happened?

As we said before, the soil can hold water because there are many small pores, which form the capillarity. The capillarity allows water to overcome its gravity and adhere to the small pores.

Cotton rope can absorb water for the same reason. Observing the cross-section of the rope, it can be seen that it is very loose and porous. There are also many small pores in the cotton rope. When the cotton rope encounters water, the capillarity will cause the water to overcome its gravity and climb up the cotton rope to fill these small pores. We know that water always flows from a higher place to a lower one, but through the capillarity, "water goes to a high place" is realized.

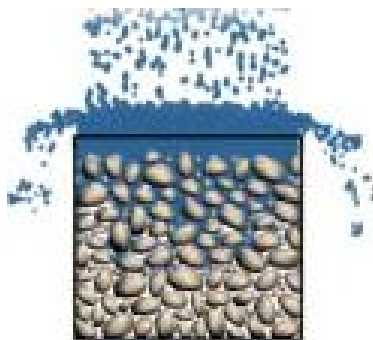

Further Development

In this activity, we made a very simple automatic watering device, and we can also try adjusting many variables in the design to make it better. For example, we can also change the watering efficiency by changing the thickness or quantity of the rope, or use a straw to cover the rope to reduce the evaporation of water. Students who are interested can give it a try!

Besides, some plants like water, while some don't, such as cacti. When using an automatic watering device in practice, it is recommended to learn whether the plants like water first!

Science Background

What is capillarity?

We know that because the soil and cotton rope are both loose and porous, the capillarity produced in the small pores allows the water to overcome its gravity and adhere to the pores. Capillarity can be understood as the attraction of small pores to liquid. Capillarity allows liquid to flow in narrow pores even under the action of gravity. The smaller the pores, the stronger the capillary action. When the pores become larger, the capillarity will become weaker due to the influence of gravity.

In life, capillarity exists everywhere, such as absorbent towels, candle

wicks, alcohol wicks, etc. In addition, plants cannot absorb water without capillarity. In plants, there are many tiny vessels. After the roots of plants absorb water in the soil, capillarity allows the water to flow along the small vessels of the plant to all branches and leaves. It can be said that without capillarity, trees cannot flourish.

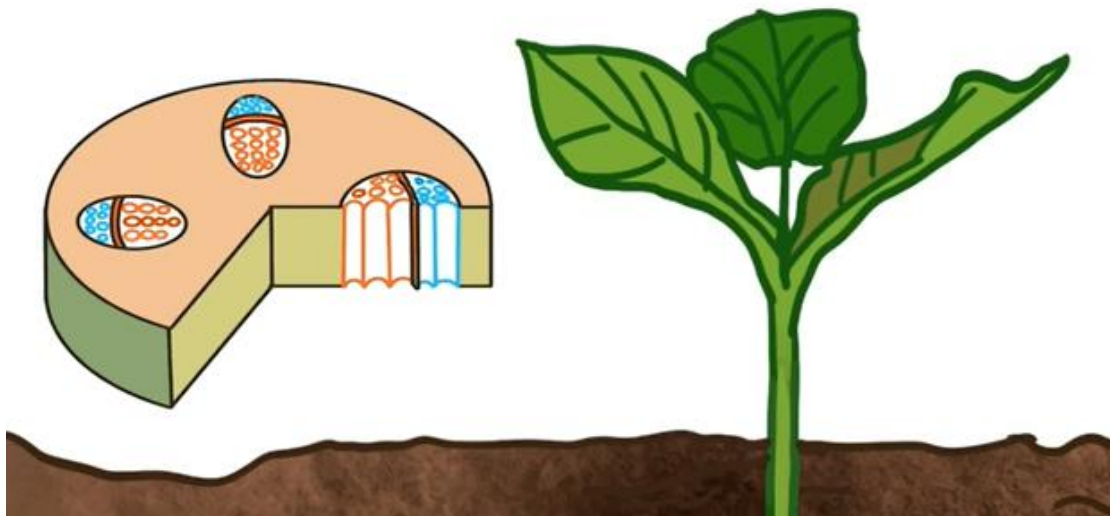

We can also observe the capillarity of plants through a simple experiment. Put the bottom of the celery stalk in a glass of water with food coloring and observe the movement of the color to the top leaves of the celery. It may take a few days. As shown in the picture below, even with the effect of gravity, colored water is still "attracted" upwards. The reason is that the capillarity of the small vessels in plants allows water molecules to move upwards.



Conclusion

In this project, we made an automatic watering device based on the capillarity of cotton rope. In further exploration, we also mentioned how to improve the efficiency of the automatic watering device by the enhancement of capillarity or the reduction of water evaporation.

The project is going to an end, please remove cables, and put all the BOSON modules back into the original positions of the kit.

LESSON 12: Burglar Alarm



Introduction

Standards

NGSS

5-PS1-3 Make observations and measurements to identify materials based on their properties.

Science - Grade 3-5

Overview

Taking "Burglar Alarm" as an open subject, the last project in this set of lessons guides students to complete engineering design tasks according to the NGSS standard steps. Just like engineers, students will find problems, set goals, design plans, build and test models, optimize and improve models, and finally complete the whole project.

Materials

All the BOSON modules in the kit.

Activity 1 DEFINE ENGINEERING PROBLEMS

Find Problems

When sleeping at night, we may worry that thieves may come into the house and steal our valuables. Think about it, can we make a burglar alarm based on the engineering design method we learned before? When the thief steals valuables, the burglar alarm will make a sound!

Engineering Goals

Make a burglar alarm.

Activity 2 DEVELOPING POSSIBLE SOLUTIONS

After determining the engineering goals, let us follow the process of “Brainstorming-Drawing Prototype Diagram-What You Need-What You Do-Test and Evaluate” to develop a solution and complete the building of the burglar alarm.

Brainstorm

Let’s first brainstorm how to build a burglar alarm. In the process, try drawing a prototype for it.

If you don't have ideas for this project, you might as well look for the project inspiration in the appendix!

Question	Reference Answer
1. What is the function of the burglar alarm?	
2. How can we make a burglar alarm?	
3. Which BOSON modules are needed?	
4. What other materials are needed?	

Draw Prototype Diagram

In the brainstorming, we have initially understood the function and structure of the burglar alarm. Try drawing a prototype diagram. In the production process, it will be an important reference.



What You Need

List the materials you need in the table below.

What You Do

Record your steps in the table below.

Step 1	
Step 2	
Step 3	
Step 4	
Step 5	

Test and Evaluate

Do you think the burglar alarm can be optimized? Try proposing an optimization plan to improve the efficiency of the burglar alarm.

Conclusion

In this project, we set up an open subject so everyone can make their burglar alarm.

The project is going to an end, please remove cables and put all the BOSON modules back into the kit according to the corresponding position.

Appendix-Reference Project

Burglar alarm based on button and buzzer

Place valuables on the button to keep it pressed. When the thief removes the item, the button will be released and the buzzer will make a sound.

Burglar alarm based on button and fan

Change the buzzer in the previous project to a fan to make an alarm sound. For example, fix small iron nails on the tip of the fan blade and place a can next to it. When the fan rotates, they will hit the can to make an alarm sound.

Burglar alarm based on buzzer and light sensor

Lock valuables in a closed and dark box. When the thief opens the box, the light sensor senses that the light becomes stronger, which can trigger the buzzer.