



## Medium W Iron & Axlebox

### Kit Contents:

- 20mm Bearing
- 25mm x 25mm Medium Duty Spring
  
- W Iron
- W Iron Keep
- 2 x Axlebox Inner Plates
- 1 x Axlebox Thin Inner Plate
- 1 x Axlebox Outer Plate
- 1 x Axlebox Outer Plate with axle hole
- 4 M6 x 35mm Hex Bolts
- 4 x M6 Nyloc Nuts
- 4 M8 x 25mm Hex Bolts
- 4 x M8 Nyloc Nuts

All parts are supplied unpainted.

## Axlebox Assembly

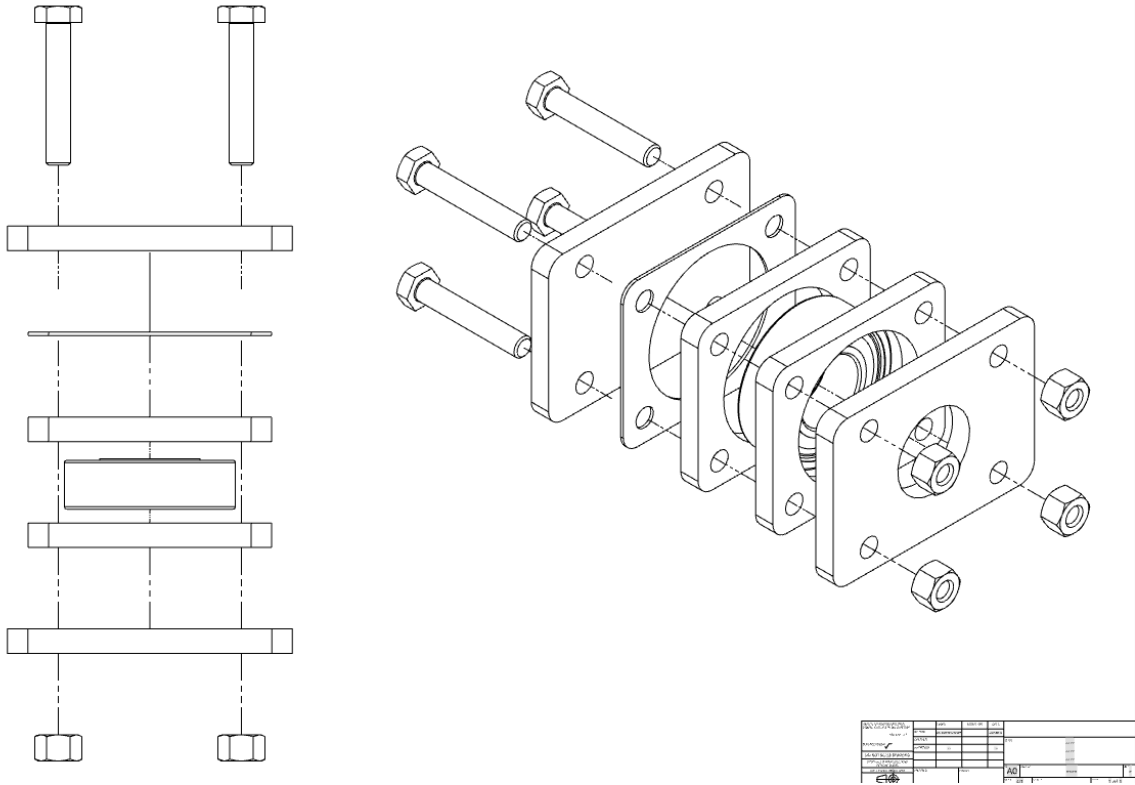

The axlebox is assembled in layers as shown in the diagram above. Use the M6 bolts and nuts to secure the plates together.

The fit of the bearing into the 'Inner Plates' is close. If it does not slide in by hand, we recommend using a vice to gently 'press' the bearing into the hole.

## W Iron Assembly

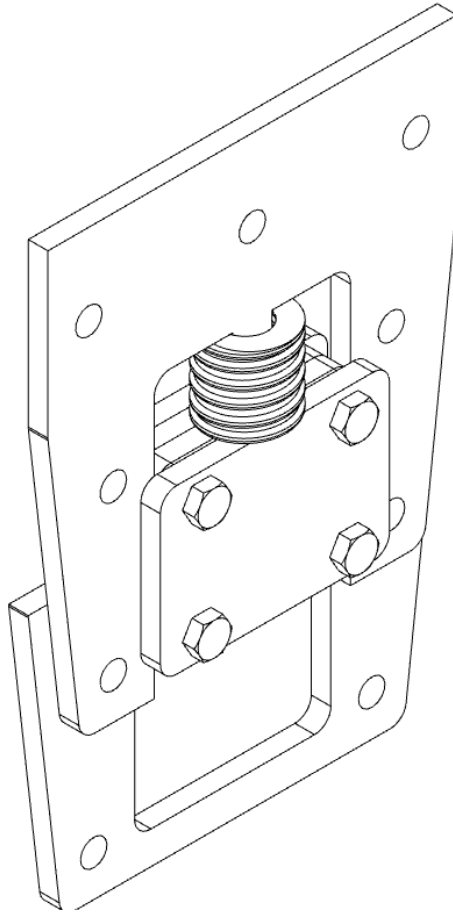

Place the spring on the locating lug of the W Iron and slide the axlebox into place. Then, slide the W Iron Keep in from the bottom. When the holes are aligned secure the keep in place with the M8 bolts and nuts.

