Laminar Flow Cabinet

Horizontal

BBS-H1300

BBS-H1800

USER MANUAL

Thank you very much for purchasing our horizontal laminar flow cabinet.

Please read the “Operating Instructions” and “Warranty” carefully before operating this unit to assure proper operation. After reading these documents, be sure to store them securely together with the “Warranty” within reach for future reference.



Warning: Before operating the unit, be sure to read carefully and fully understand important warnings in the operating instructions.

Version 2021.12

CONTENT

1. Unpacking, Installation and Debugging	3
1.1 Unpacking	3
1.2 Accessories Checking	5
1.3 Installation Conditions and Operating Environment	7
1.4 Installation.....	7
1.5 Inspection after Installation.....	11
2. User Instructions	12
2.1 Functions.....	12
2.2 Product Structure	14
2.3 Instructions of Operation	18
2.4 Daily Maintenance	19
2.5 Replacement Parts List.....	21
2.6 Wiring Diagram	23
3. Trouble Shooting and Solution	24
3.1 Common Failures and Solutions.....	24
3.2 Replace the Fuse.....	26
3.3 Replace Fluorescent Lamp.....	27
3.4 Replace UV lamp.....	28
3.5 Label Description.....	28
4. Warranty.....	29

1. Unpacking, Installation and Debugging

Please firstly check if the packing box is in good condition. If the packing box is damaged, please take photos.

1.1 Unpacking

Choose proper tools and unpacking method as shown in the below picture.

For wooden box:

1) Method 1 Necessary tools for unpacking: Electric drill with hexagon dead M8(Picture 1)



Picture 1

2) Method 2 Use M8 Wrench to unpack(Picture 2)



Picture 2

The following diagram demonstrates quick unpacking procedures (Picture 3). Remove the screws as shown in the below diagram, then remove the wooden sheet to right and left of the wooden box

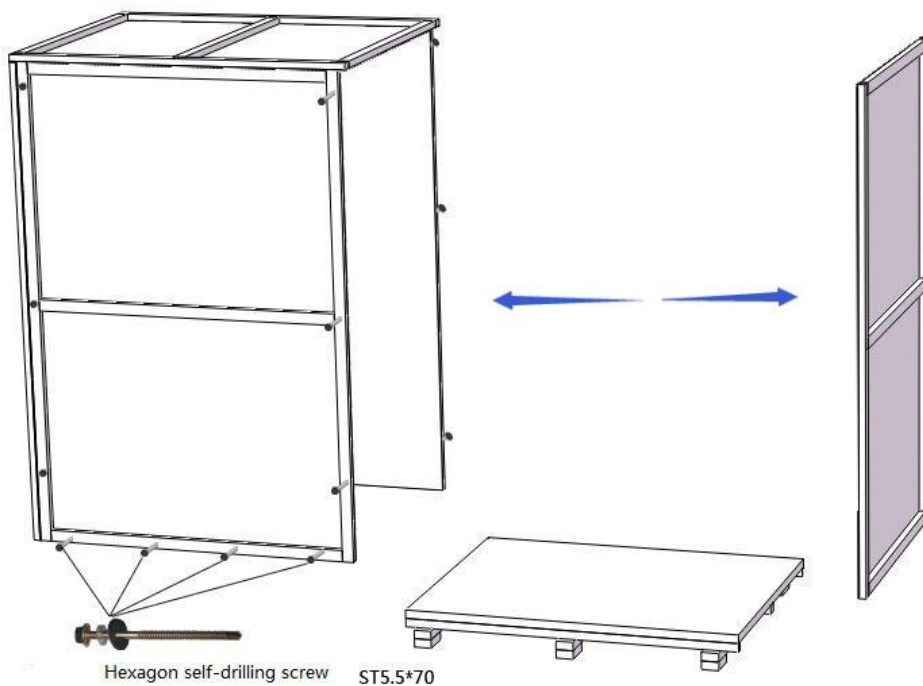

Picture 3

1.2 Accessories Checking

Refer to the packing list and check the accessories.

BBS-H1300 Packing list

Items	Quantity	Position
Main body	1unit	Wood packaging
Base stand	1unit	Paper (Behind the cabinet)
Power Cord	1pc	Bags(Behind the cabinet)
Fuse (10A)	1pc	Bags(Behind the cabinet)
UV Lamp(T6 30W)	1pc	Paper(Behind the cabinet)
Gas Tap SAN-3102	1pc	Paper(Behind the cabinet)
Water Tap SAN-2102	1pc	Paper(Behind the cabinet)
BBS-H1300 User Manual	1pc	Envelope(Behind the cabinet)
Test report	1pc	Envelope(Behind the cabinet)
Quality certification card	1pc	Envelope(Behind the cabinet)
Warranty Card	1pc	Envelope(Behind the cabinet)
Product acceptance certificate and installation report	1pc	Envelope(Behind the cabinet)
Training certificate	1pc	Envelope(Behind the cabinet)
Hexagon cylinder head bolt M10*55	3 sets	Bags (Behind the cabinet)
flat washer 10+ Spring washer 10	3 sets	Bags (Behind the cabinet)
Allen wrench	1pc	Bags (Behind the cabinet)

BBS-H1800 Packing list

Items	Quantity	Position
BBS-H1800 Main body	1unit	Wood packaging
BBS-H1800 Base stand	1unit	Paper (Behind the cabinet)
Power Line	1pc	Bags(Behind the cabinet)
Fuse (10A)	1pc	Bags(Behind the cabinet)
UV Lamp(T6 30W)	1pc	Paper(Behind the cabinet)
Gas Tap SAN-3102	1pc	Paper(Behind the cabinet)
BBS-H1800 User Manual	1pc	Envelope(Behind the cabinet)
Test report	1pc	Envelope(Behind the cabinet)
Quality certification card	1pc	Envelope(Behind the cabinet)
Warranty Card	1pc	Envelope(Behind the cabinet)
Product acceptance certificate and installation report	1pc	Envelope(Behind the cabinet)
Training certificate	1pc	Envelope(Behind the cabinet)
Hexagon cylinder head bolt M10*55	3 sets	Bags (Behind the cabinet)
flat washer 10+ Spring washer 10	3 sets	Bags (Behind the cabinet)
Allen wrench	1pc	Bags (Behind the cabinet)

1.3 Installation Conditions and Operating Environment

Laminar Flow Cabinet shall be placed in the protective area of an air stream, and the working area of the Laminar Flow Cabinet can not be near to the door or window, and should be away from the air outlet to prevent the air flow from the ventilation system, air conditioning, door, window and personnel.

At least 300mm gap must be kept in the side and back side of the Laminar Air Flow for clean operating and for inspection.

Working environment:

- a. Only applicable for indoor operation;
- b. Ambient temperature: 15° C ~35° C
- c. Relative Humidity: ≤75%;
- d. Atmospheric pressure range: 70KPa~106KPa;
- e. Electrical parameters: Adequate power supply to the laminar flow cabinet(See 2.1.4 Technical Parameters);
- f. Power supply need to be grounded; (Judging method: test the live wire and the neutral wire of the socket with multimeter. The voltage between live and ground should equal to the voltage of local electrical grid, and the voltage between neutral and ground should equal to 0. Otherwise the power supply is not grounded correctly);

1.4 Installation

- a. Remove all the packing materials;
- b. Check the surface of main body to make sure there is no scratch, deformation or foreign bodies;
- c. Confirm the complement of accessories according to the list.
- d. Before removing the packing material, move the entire equipment to the place where it is going to be installed.



The base stand will be packed at back of main body, please take it out before installation. DO NOT INVERT, DISASSEMBLE OR TILT THE CABINET during transportation.

- e. Assemble the base stand with main body as shown in the picture.

Please connect the base stand with the main body referring to Picture 4

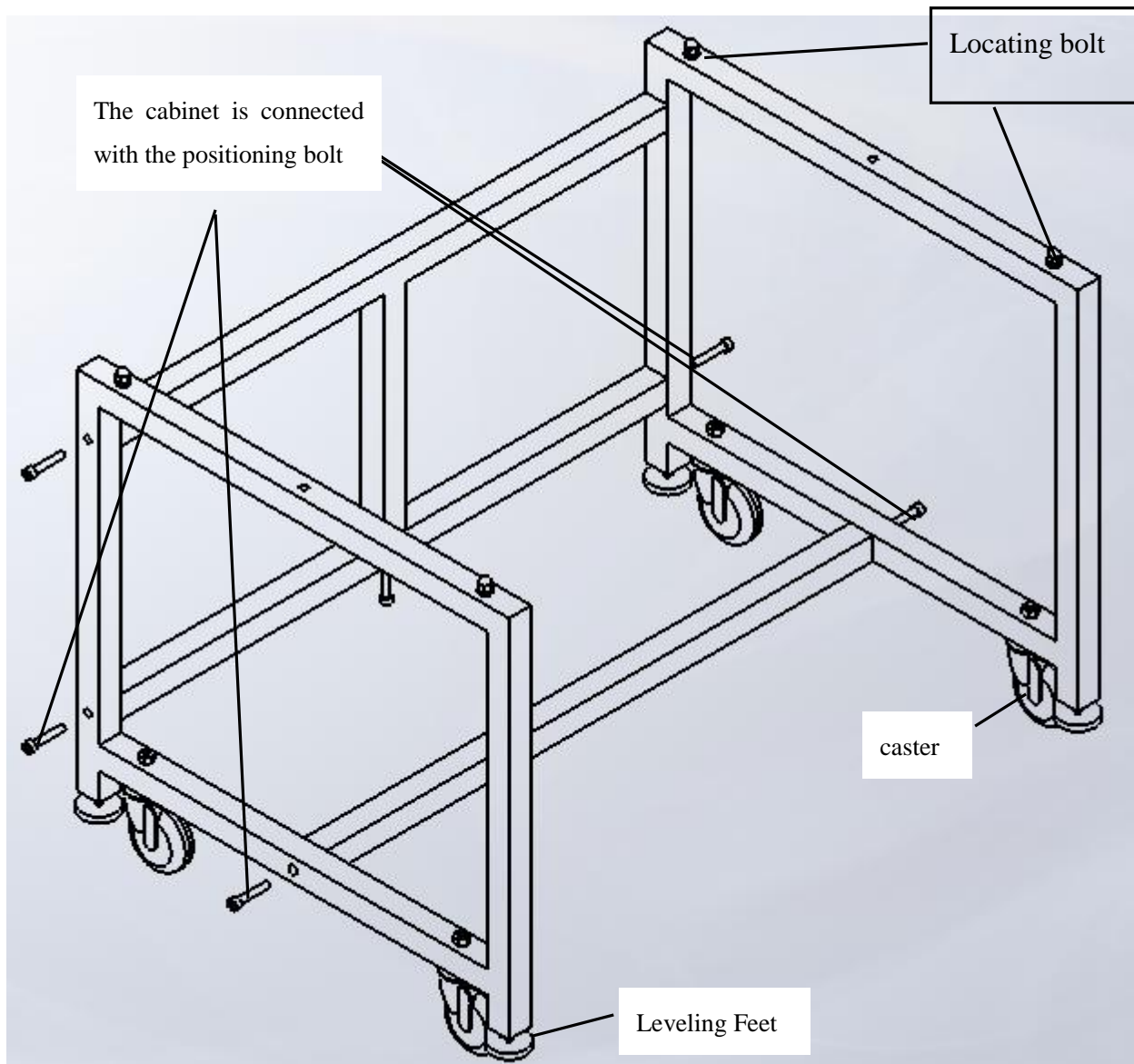

Picture 4

Removing Hexagon cylinder head bolt on both side lateral brace and T frame, the bottom of T frame, assemble referring to the picture, fasten the screw and Cap nut on the both side of base stand.

Foot height can be adjusted. Clockwise rotation of feet, when feet height is less than casters, the cabinet can be (or base stand) moved; anticlockwise rotation of feet, when feet height is greater than casters, then play a fixed role in preventing the cabinet (or base stand) from moving.



If you have any questions please contact engineers for commissioning

f. connecting main body and base stand.

Please connect main body and base stand refer to Picture 5 .



Picture5

First, keep the main body above the base stand. (picture 5), then align the bolt of base stand.

Mounting holes of the Main body at both sides, using Hexagon head bolt M10*55, flat washer 10, Spring washer 10 insert through base stand and the side panel and make them stable.

g. Pick up the gas (water) tap from accessory kit, first, unscrew the tap and nut, find the Mounting holes at the both side of cabinet glass. The Tap needs to be fixed as shown in the picture. The water mouth of the Tap should be inside the cabinet's operating zone, refer Picture 6, The other end of the Tap which is having threading on the pipe should be inserted through the glass hole, the threaded pipe should be fastened with washer and nut outside the glass and need to be tightened with a wrench. Please refer the below picture to carry out the tap fixing to the cabinet. See picture 6 and 7.

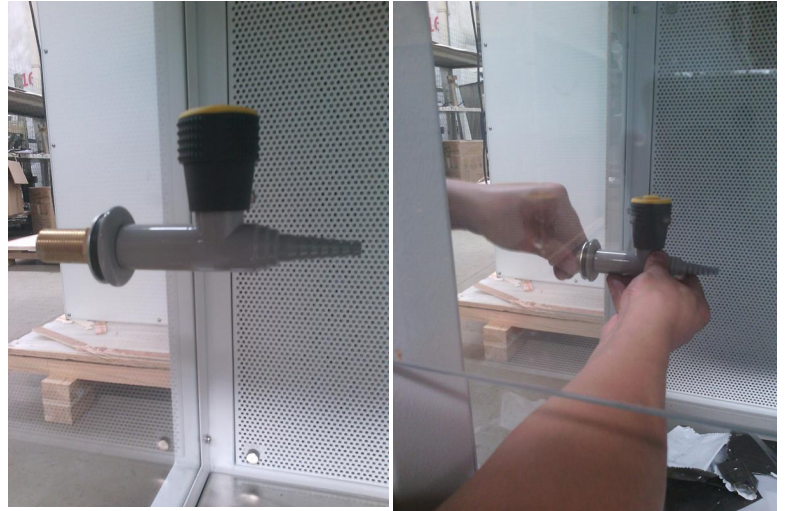

Picture 6



Picture 7

h. After the above steps, move cabinet to the right cabinet position slightly, remove the power cord, check the power cord is intact.

1.5 Checking after installation

First, make sure the voltage and frequency to be same as nameplate showing, and then check the follows items with power on:

Checking Items	Normal working status
Fan motor	Running normally
Fluorescent lamp	Lamp lights up after pressing button
UV Lamp	Lamp lights up after pressing button
Display screen buttons	All buttons can be used
Socket	Use multimeter to test voltage output after pressing the socket button



If you have any questions please contact engineers to commissioning, Debugging methods in the service manual

2. User Instructions

2.1 Functions

2.1.1 Product Concept

Laminar Flow Cabinet – **is used only for sample protection.**

Laminar Flow Cabinet is a work bench or similar enclosure, which creates a particle-free working environment by taking air through a filtration system and exhausting it across a work surface in a laminar or unidirectional air stream.

It is widely divided into vertical and horizontal laminar airflow type.

This series is for horizontal type.

2.1.2 Operating Principle/Air flow Pattern

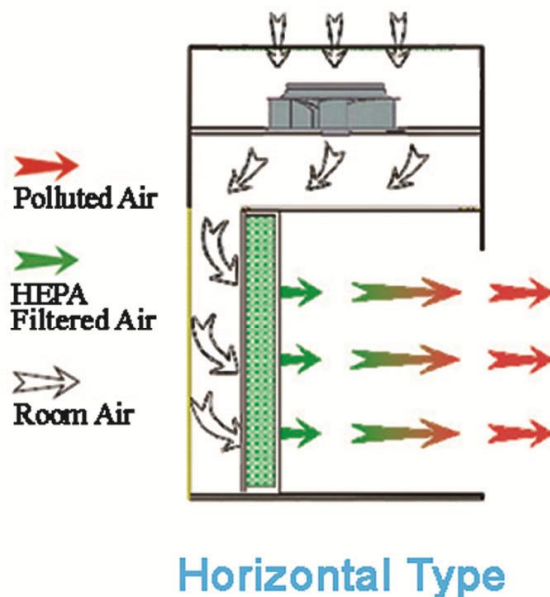

Picture 8

2.1.3 Protected Objects

Laminar flow cabinet is to protect the experimental material, to create a local high cleanliness air environment, the main role is to ensure the accuracy of the operating area of the experiment, but for the environment and operators can't afford protection.

2.1.4 Technical Parameters

Model Parameters	BBS-H1300 <input type="checkbox"/>	BBS-H1800 <input type="checkbox"/>
External Size (W*D*H)	1300*820*2040 mm	1800*820*2070 mm
Internal Size(W*D*H)	1200*500*570 mm	1700*500*570 mm
Power Supply	AC 220V±10% <input type="checkbox"/>	AC 110V±10% <input type="checkbox"/>
Frequency	50 Hz <input type="checkbox"/>	60Hz <input type="checkbox"/>
Consumption	400W	500 W
Airflow velocity	0.3~0.5m/s	
UV Lamp Consumption	30W*1	30W*1
Fluorescent lamp Consumption	12W (LED)*1	16W (LED)*2
HEPA Filter	99.999% efficiency at 0.3 um	
Noise	≤65dB	

Notes: We reserves the rights to make changes in future product design, without reservation and without notification to its users.

1) Vibration amplitude

The net vibration amplitude, at a range of frequency from 10Hz to 10KHz, would not exceed 5 μm .

2) Illumination

The average illumination is more than 350 lux

3) Electrical properties

The cabinet would not breakdown in 5s when the voltage increases by 1390V (AC) within 5s.

Grounding resistance ≤0.1Ω

2.2 Product Structure

2.2.1 Structural Composition of BBS-H1300/BBS-H1800



Picture 9

- | | |
|--------------------|-----------------------|
| 1. Glass door | 8. Water, gas tap |
| 2. Power socket | 9. Side window |
| 3. Ground terminal | 10. Work table |
| 4. Control panel | 11. Base Stand |
| 5. Power switch | 12. Support foot |
| 6. UV lamp | 13. Footmaster caster |
| 7. LED light | |

2.2.2 Structure Introduction

1) Driving system of front window

Driving system consists of tubular motor, front window, hauling mechanism and limit switch.

2) Air filtration system

Air Filtration System is the most important system. It consists of blower and HEPA filter. The function of Air Filtration System is transferring filtered air to work area, ensure air flow velocity, and keep Class 100 cleanness of work area.

3) UV lamp

The entire work zone could be sterilized effectively by the UV lamp located at the top of work zone. Emission of 253.7 nanometers could ensure the most efficient decontamination.

4) LED light

The laminar flow cabinet is equipped with LED light, which ensures the standard requirement of average illumination is met.

5) Control Panel

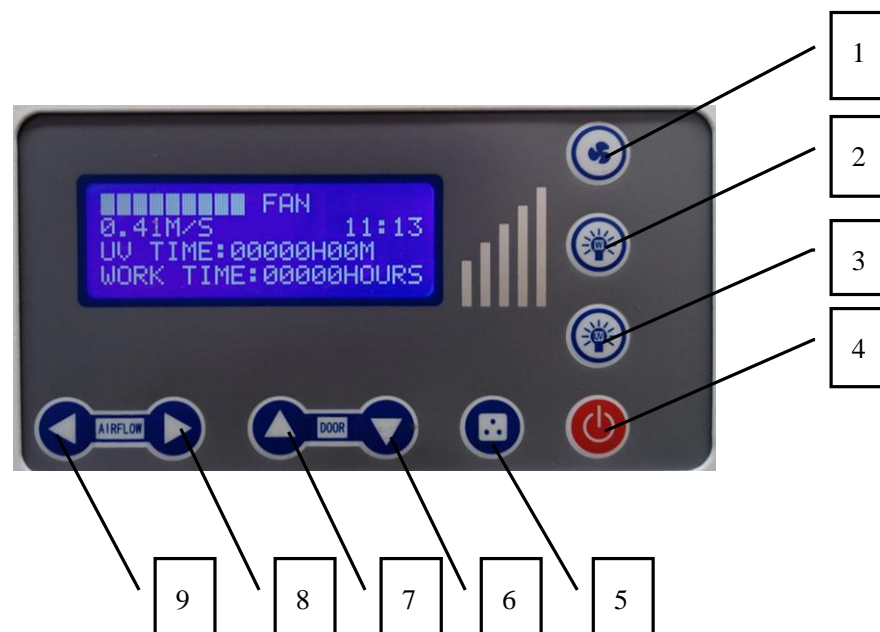

Picture 10

- | | |
|---------------------|-----------------------------|
| 1. blower | 6. Front window Up Status |
| 2. Fluorescent Lamp | 7. Front window Down Status |
| 3. UV lamp | 8. Air volume decreases |
| 4. Power | 9. Air volume increases |
| 5. Socket | |

a. Gear Display

You can know working wind speed by gear display.

b. Soft touch buttons.

The main operation of the device can be carried out by touching button

(1)  : The power button

(2) : To control blower working status. Blower has memory function, next boot blower gear shows the last shut down, to avoid each boot need to adjust the fan, (It will not work when front window is fully closed.)



(3) :To control fluorescent lamp



(4) :To control UV lamp(UV lamp, blower, fluorescent lamp and front window interlock, it won't work when fluorescent lamp, blower, front window open)

(5) : To control socket power status.

(6) : Press Down button, front window will fall down. Each time you press, the buzzer will sound once; hold this key, the front window will continue to decline; release the button, the front window will stop declining.

(7) : Press UP button, front window will raise. Each time you press, the buzzer will sound once; hold this key, the front window will continue to rise; release the button, the front window will stop rising.

(8) :To control blower speed down. When blower is working, if  number is More than 1, Each time you press, wind speed can down a gear, and the buzzer rings once.



(9) :To control blower speed increase. When blower is working, if  number is less than 9, Each time you press, wind speed can increase a gear, and the buzzer rings once.

(10) LCD display: When powered on, from top to bottom is  FAN, It indicates

the strength of blower wind speed, Shown below is the current state of the Winds; The right of the display is time; UV TIME, UV lamp working time; WORK TIME: HEPA filter working time.

(11) Under standby status, press the fluorescent lamp button and then press and hold the power button for 5 seconds. The clock could be adjusted after a buzz alarm.

Press UP and DOWN to adjust the number and press mute button to switch from minute to hour. After setting the time correctly, press fluorescent lamp button and then press and hold the power button for 5 seconds. A buzz alarm indicates that the time has been saved).

(12) UV lamp timing: In standby mode, when the front window is lowered to a minimum, please press UV lamp control button , then the UV lamp is opened. After opening the UV lamp, the display will show the current status of the UV lamp timing: By pressing blower speed down button , the setting time will be reduced one minute each time; by pressing blower speed up button , the setting time will get be increased one minute each time. You can set the time as needed (UV lamp timing range is 0-90 min, and the max factory setting is 90 min)

6) Water proof Socket

Waterproof socket is arranged in the operating area, to within the operating area of the power supply equipment and in the lighting lamp installing the front side plate (Picture 11) and need to use a socket, open the power supply equipment, press the display of the socket button (Picture 10), the waterproof socket open cover, access to electricity source plug.



(1) Please make sure the total load of sockets should be $\leq 500W$;

(2) Waterproof socket only when the front cover down to the waterproof, the front cover is opened, the socket can not be considered waterproof socket.

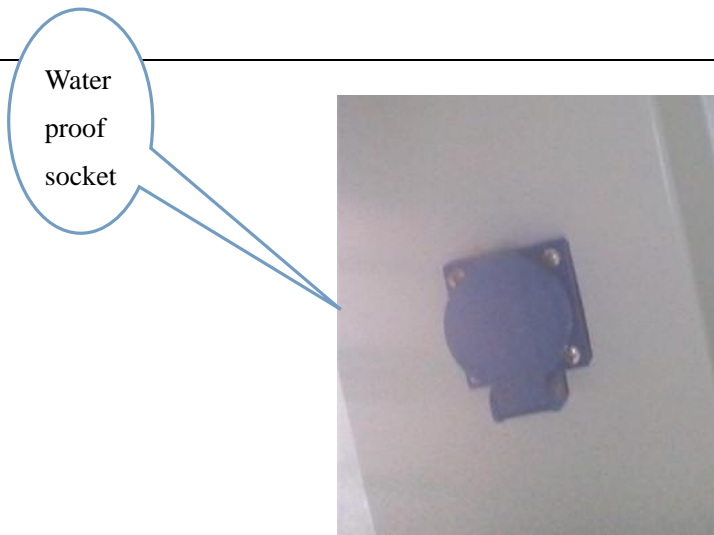

Picture11

7) Fuse

The equipment is equipped with main power fuse, They are located near the power cord's outlet. Fuse label is corresponding to the relevant specifications.

8) Control of Front Window

Front window is motorized

9) Structure

- a) Cabinet body is built up of 1.2mm cold-rolled steel with anti-powder coating. Strong and steady.
- b) Work table is fully made up of 304 stainless steel which looks beautiful and with corrosion resistance performance.
- c) Base stand is made up of cold-rolled steel with anti-powder coating.
- d) Soft touch type control panel, easy to handle and beautiful appearance.

2.3 Instructions of Operation

2.3.1 Normal Operation Notice

- (1) Make sure input voltage is correct and stable. The rated load of main power socket should be higher than cabinet consumption. Plug must be well grounded.
- (2) Moving principles of different samples inside cabinet: When two or more samples need to be moved, be sure that low-polluting samples move to high-polluting samples. Movement of items should also follow the principles moving slowly and stably.
- (3) The weight of items placed in the cabinet should not be more than 23Kg/25×25cm²;
- (4) Avoid vibration: avoid using vibration equipment (eg centrifuges, vortex oscillator, etc.)

inside the cabinet. Vibration would cause lower cleanliness of operating area and affect operator protection.

- (5) No flame: No flame is allowed inside the cabinet. Using of fire will lead to airflow disorder, and filter damage. If sterilization is required during the experiment, infrared sterilizer is highly recommended.
- (6) HEPA filter life: With the usage time increasing, dust and bacteria accumulate inside HEPA filter. Filter Resistance is getting bigger, when it reaches the maximum point, the speed requirements can't be met. Then need contact our service department to get a new one. The used filter should be processed as medical waste.
- (7) The steel plate is under fan, which is sealed strictly in the factory. The operator is not allowed to remove or loose screws of those parts. If necessary, please contact service personal.
- (8) The maximum storage period is one year. If the period is more than one year, performance test should be done .



Serious declaration: We will take no responsibility for risks caused by improper operation and man-made damages!

2.3.2 Operation Process

- a. Connect to a suitable power supply
- b. Press the relevant key functions (related keys, function and operation of the 2.2.2 in the description); check the function keys and the operation results are consistent, and according to the above clean table technical parameters of the test whether the normal start and wind speed is up to the standard requirements, lighting and ultraviolet lamp is normal work.
- c. The cabinet should be sterilized by UV lamp for at least 30 minutes with the window fully closed before any experiment.



(1) For safety of eyes and skin, people should leave the room during the UV sterilization.

(2) UV lamp should be checked regularly. It should be replaced when either the total working time reaches 600 hours or the intensity is lower than the requirement.

- d. Please move up the front window at the suitable height above the work table and turn on the fan. Make sure the experiment should be started after fan working for at least 30 minutes..



For operating safety, please place the experiment materials inside the cabinet before experiment start.

After finishing the experiment, please fully close the front window and make sure to sterilize the cabinet by UV lamp for 30 minutes before turning off the cabinet.

2.4. Daily Maintenance

Preparations before maintenance: removal of items in the equipment

Preparation of goods: cotton or towel, concentrated soap, hot water, water, medical alcohol or other disinfectants, etc.

2.4.1 Clean the Cabinet Surface

Clean the surface of working zone

Wipe the entire surface with a soft cotton cloth which has been soaked with concentrated liquid soap. Afterwards, wipe off the foam with another cotton cloth or towel which has been soaked with clean hot/warm water. At the end, wipe the entire surface with a dry cotton cloth or towel rapidly.

For the contaminated or dirty work surface and sump, use 70% rubbing alcohol or other disinfectant to wipe.



Disinfectants used for wiping should not damage the 304 stainless steel.

2.4.2 Clean the external surface and front window.

Use a piece of soft cotton cloth or towel to wipe the surface with non-abrasive household cleanser.

2.4.3 Overall maintenance period

The recommended interval period for comprehensive maintenance is either one year or 1000 working hours.

2.4.4 Maintenance methods

1) Weekly or daily maintenance

- a. Disinfect and clean the operating area;
- b. Clean the external surface and front window around the operating area (Reference 2.4.1 instruction);
- c. Check the various functions of the cabinet (Reference 2.4.2 instruction);
- d. Record down the maintenance result

2) Monthly maintenance

- a. Clean the the external surface and front window (Reference 2.4.2 instruction).
- b. Use towel with 70% rubbing alcohol or 1:100 dilution of household bleach to wipe the working table, the inner face of front window and the inner wall surface of the working area(exclude the top wind grid). Use another towel with sterile water to wipe those area to erase the remain of

chlorine.

- c. Check the various functions of the cabinet;
- d. Record down the maintenance result;

3) Annual maintenance

- a. Check the two lifting belt of the front window tubular motor, make sure both of them are well connected to the motor with same tightness.
- b. Check the UV lamp and LED light.
- c. Apply for overall performance test of the cabinet annually to ensure that the safety meets requirements. User is responsible for testing costs.
- d. Record down the maintenance result.



When doing maintenance, please pay attention to cut off the power, so as to avoid electric shock!

2.4.5 Storage conditions

Laminar flow cabinet should be stored in a warehouse with relative humidity not more than 75% and temperature lower than 40°C. The warehouse should have good ventilation performance without acid, alkali or other corrosive gases. Storage period shall not exceed one year. Laminar flow cabinet stored for more than one year needs to be unpacked and checked before selling and using. Only the tested and qualified laminar flow cabinet could be sold.

2.5 Replacement Parts List

BBS-H1300 replacement parts list

Number	Name	Specification
BR-01	Fuse	10A
BR-02	Lamp holder T8	LG13-01A
BR-03	UV Lamp	T6 30W
BR-04	LED T5 stand	T5 12W
BR-05	UV lamp ballast	1*TL8-30W
BR-06	HEPA filter	1223*570*69
BR-07	Fan	FH320A
BR-08	Control panel	LCD Control panel

BR-09	Front window	1223*640*5
BR-10	Left Side window	539*405*5
BR-11	Right Side window	539*405*5 (has hole)
BR-12	Single wall gas tap	SAN-3102
BR-13	Tubular motor	TMN45-10/17

BBS-H1800 replacement parts list

Number	Name	Specification
BR-01	Fuse	10A
BR-02	Lamp holder T8	LG13-01A
BR-03	UV Lamp	T6 30W
BR-04	LED T5 stand	T5 16W
BR-05	UV lamp ballast	1*TL8-30W
BR-06	HEPA filter	1720*570*69
BR-07	Fan	FH355A
BR-08	Control panel	LCD Control panel
BR-09	Front window	1723*640*5
BR-10	Left Side window	539*405*5
BR-11	Right Side window	539*405*5 (has hole)
BR-12	Single wall gas tap	SAN-3102
BR-13	Single wall water tap	SAN-2102
BR-14	Tubular motor	TMN45-20/17

2.6 Wiring Diagram (Picture 12)

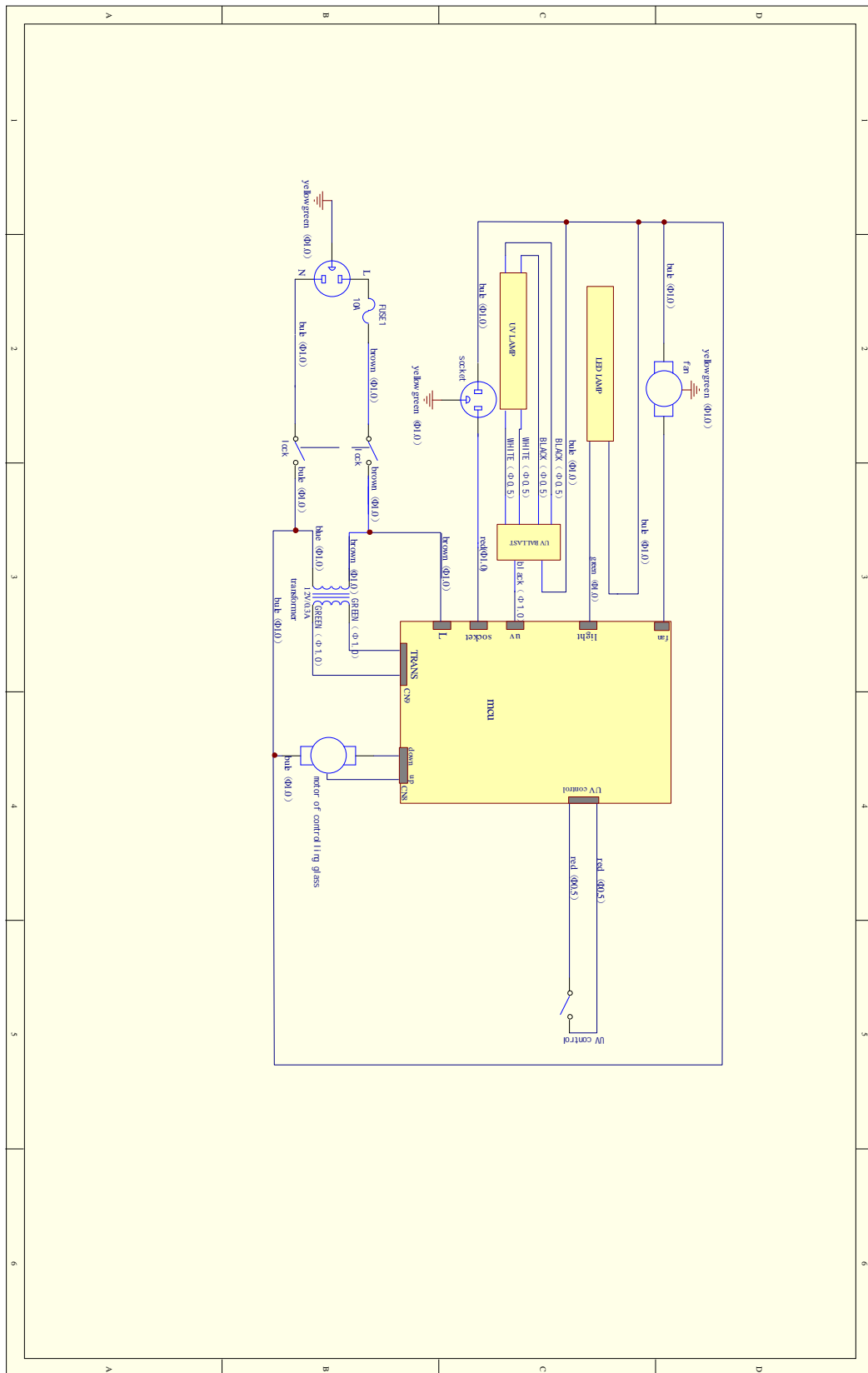

Picture 12

3. Trouble Shooting and Solution

3.1 Common Failures and Solutions

Please confirm that the power is well connected, the cord is in good condition(without any damage) and the power lock is unlocked before trouble shooting the following problems.

Failure	Checking Part	Suggestion
Fluorescent lamp fail to work	Lamp holder	Connect the tube and lamp holder tightly
	Lamp	Replace the lamp
	Circuit	Check the circuit
	LED stand plug	Connect the plug and stand tightly
	LED stand	Replace stand
	Ballast	Replace the ballast
	Control panel	Replace the control panel
UV lamp fail to work	Interlock	Make sure the front window is fully closed; the fluorescent lamp and the blower are not in work.
	Lamp holder	Connect the tube and lamp holder tightly
	Circuit	Check the circuit
	Ballast	Replace the UV lamp tube
	UV lamp	Check if the micro switch is broken
	Micro Switch	Replace the control panel
	Control panel	Connect the tube and lamp holder tightly
Button fail to work	Control panel	Make sure the power is well connected and the fuse is in
		Check if the button is broken
		Make sure the connecting wire is well connected
		Replace the control panel
Blower fail to work	Micro switch	Check if the micro switch is broken
	Blower	Replace the blower if it is defective
	Circuit	Check the circuit
	Control panel	Replace the control panel
No electricity in equipment	Power supply	Check whether the power supply is well connected
	Power wire	Check whether power cord is in good condition
	Fuse	Check whether the fuse is damaged
	Power key	Check whether the power key is locked or damaged
	Control panel	Replace the control panel
	Potential transformer	Check whether the transformer works normally
Display fail to work	Connection winding displacement	Connection winding displacement
	Display screen	26 Check whether the screen is in good condition
	Control panel	Replace the control panel

Front window fail to work	Circuit	Check the circuit
	Motor of front window	Check the front window motor
	Transmission part	Check the transmission connection and lead rail
	Control panel	Replace the control panel



NOTES

- (1) **The above trouble shooting methods should be done by qualified electricians under safe conditions(cut off power supply). Other components should not be removed. Risk caused by failing to follow those instructions would be responsible by user.**
- (2) **Please contact our technical department or agent if a failure could not be traced or solved. Do NOT repair the equipment without a qualified electrician.**
- (3) **The trouble shooting and repair of this equipment only could be undertaken by trained and recognized technicians;**
- (4) **Please contact our technical department or agent to order required component or part. The model number and the serial number of purchased cabinet need to be indicated.**

3.2 Replace the fuse

For replacing the fuse, turn off the power and disconnect the plug. Use a Phillips screwdriver and rotate it anticlockwise to unscrew the fuse holder. Replace the fuse inside the fuse holder and then, use a Phillips screwdriver and rotate it clockwise to screw back the fuse holder.

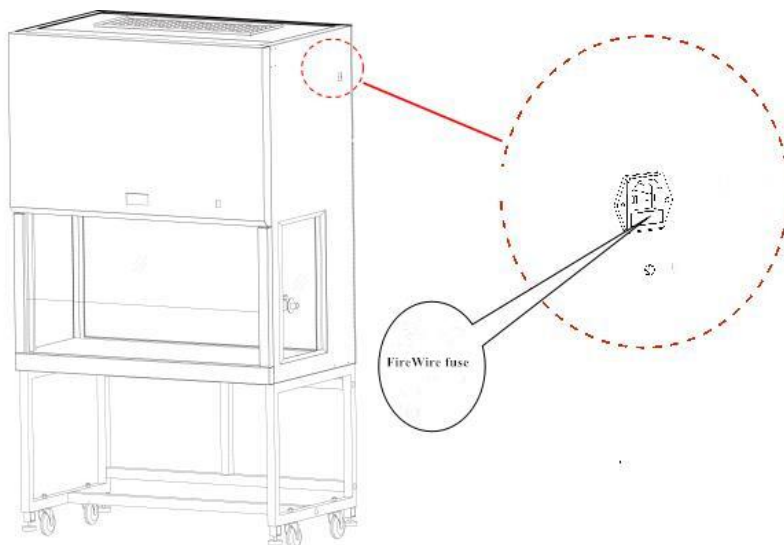

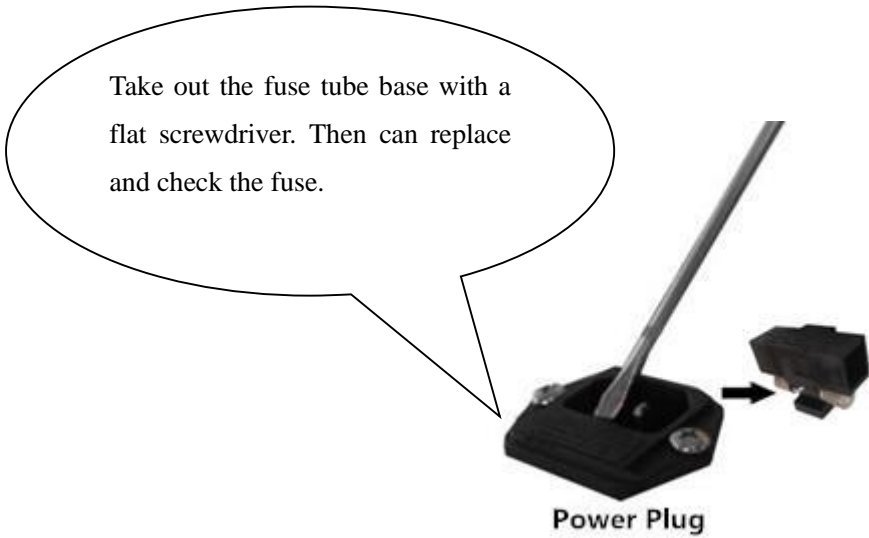

Picture 13

3.3 Replace fluorescent light

When the fluorescent light needs to be changed, turn off the power. Then remove the LED stand, unplug the right side, After replacing a new LED stand, inserted into the inclined slot.



3.4 Replace the UV lamp

UV lamp should be replaced regularly according to the frequency of use, when using UV lamps reach to the time of 600 hours, we recommend to replace the lamp. When replacing, press UP button to raise front window to the highest level, and turn off the power, and then screw the bulb 90 ° and take it off, then take the correspondence type of lamp, and put it to the lamp holder and and screw 90 ° in reverse direction. (picture 14)

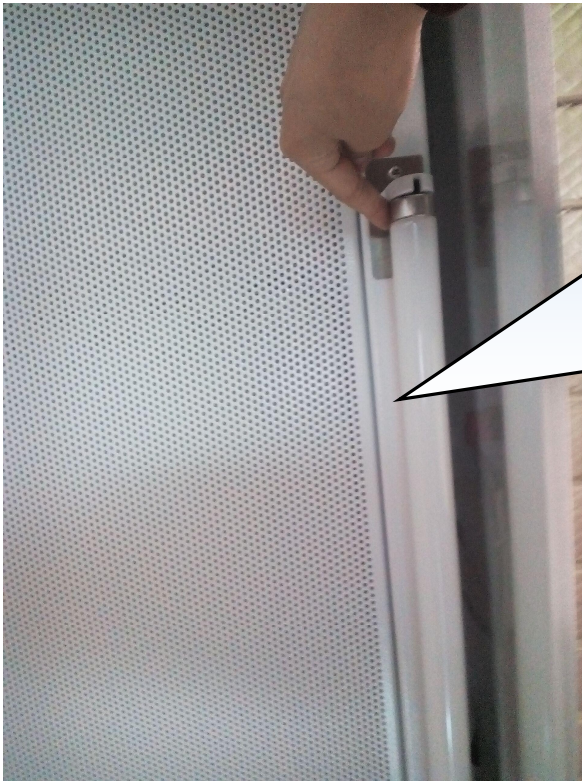

Hands are respectively arranged on the two ends of the lamp tube, close to both sides of the lamp holder and hands at the same time, the lamp clockwise (or counterclockwise) is rotated 90 degrees, as shown in figure will tube under, after careful aside, take new tube is inserted in the lamp holder, according to the above method, the tube clockwise (or counterclockwise) is rotated 90 degrees, to complete the installation, test can be.

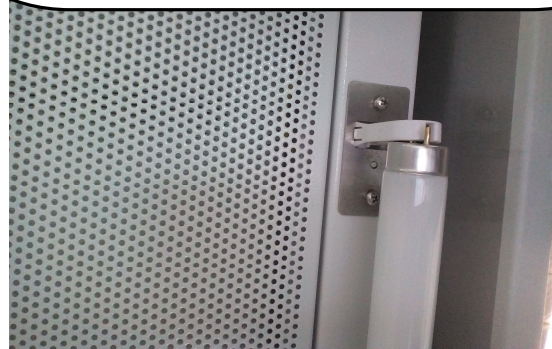

Picture 14

3.5 Label Description (Picture 15)

3.5.1 Fuse label

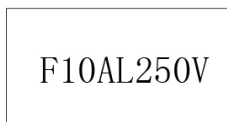

Picture 15

Note:10A power fuse label

3.5.2 Ground label (Picture 16)



Picture 16

4. Warranty

4.1.1 Warranty is 12 months from EX-factory date (excluding consumable accessories: UV lamp, fluorescent lamp and fuse).

4.1.2 We would not be liable for any repair of damage caused by improper operation.

4.1.3 If the warranty has been expired, we would still responsible for repair with relative charges.

4.1.4 Life time of laminar flow cabinet is 8 years from production date on the label.

4.1.5 We would provide equipment drawings and necessary technical data for maintenance companies or personnel trained by our engineers.

Warranty declaration: One-year Warranty, Life-long Maintenance