**Vertical Laminar Flow Cabinet
BBS-V1300/V1800
User Manual**

Version 2021.03

Preface

Thank you very much for purchasing our vertical laminar flow cabinet.

Please read the “Operating Instructions” and “Warranty” carefully before operating this unit to assure proper operation. After reading these documents, be sure to store them securely together with the “Warranty” within reach for future reference.



Warning: Before operating the unit, be sure to read carefully and fully understand important warnings in the operating instructions.

Content

Preface.....	1
Content.....	2
1.Unpacking, Installation and Debugging	4
1.1 Unpacking.....	4
1.2 Accessories Checking	6
1.3 Installation Conditions and Operating Environment	7
1.4 Installation.....	8
1.5 Inspection after Installation.....	10
2. User Instructions	12
2.1 Functions.....	12
2.1.1 Product Concept.....	12
2.1.2 Works / airflow mode protection area	12
2.1.4 Technical Parameters	13
2.2 Product Structure	14
2.2.1 Structural Composition of BBS-V1300/BBS-V1800	14
2.2.2 Structure Introduction	15
2.3 Instructions for Operation	18
2.3.1 Normal Operation Notice.....	18
2.3.2 Operation Process	18
2.4. Daily Maintenance	19
2.4.1 Clean the cabinet surface	19
2.4.2 Clean the external surface and front window	19
2.4.3 Overall maintenance period	19
2.4.4 Maintenance methods	19
2.4.5 Storage conditions.....	20
2.5 Replacement Parts List	20
3. Trouble Shooting and Solution	23
3.1 Trouble Shooting	23

3.2 Replace the fuse	24
3.3 Replace fluorescent light.....	25
3.4 Replace the UV lamp	25
3.5 Label Description (Picture 16).....	26
4. Warranty.....	27

1.Unpacking, Installation and Debugging

Please firstly check if packing box is in good condition. If the packing box is damaged, please take photos.

1.1 Unpacking

Choose proper tools and unpacking method as shown in the below picture.

For wooden box:

1) Method 1 Necessary tools for unpacking: Electric drill with hexagon dead M8



Picture 1

2) Method 2 Use M8 Wrench to unpack

The following diagram demonstrates quick unpacking procedures (Picture 3). Remove the screws as shown in the below diagram, then remove the wooden sheet to left of the wooden box.



Picture 2

The following diagram demonstrates quick unpacking procedures (Picture 3). Remove the screws as shown in the below diagram, then remove the wooden sheet to left of the wooden box.

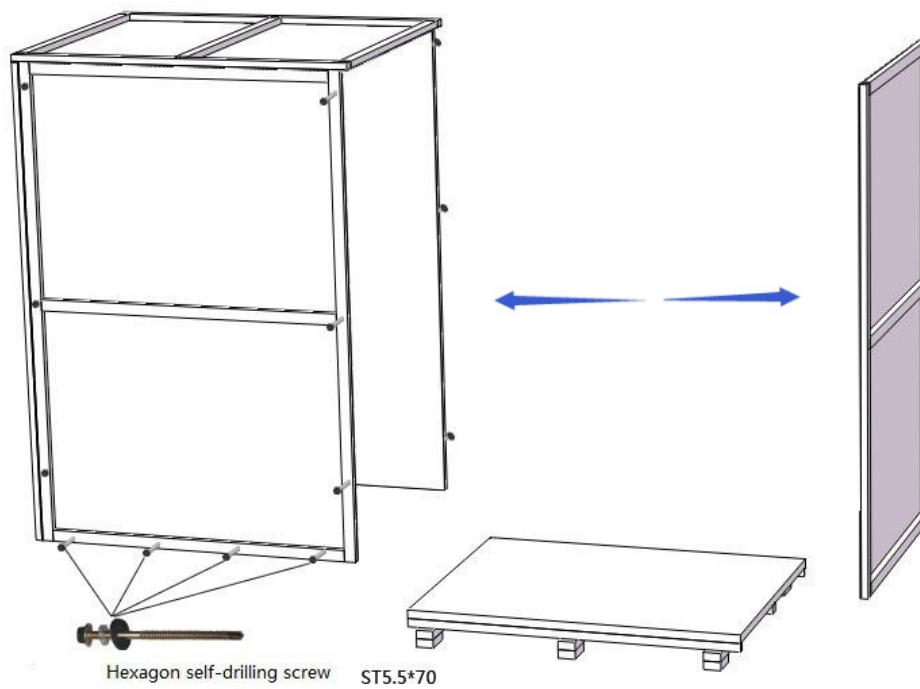

Picture 3

1.2 Accessories Checking

Refer to the packing list and check the accessories.

BBS-V1300 Packing list

Items	Quantity	Position
Main body	1unit	Wood package
Base stand	1set	Paper package(Behind the cabinet)
UV Lamp(T6 30W)	1pc	
Gas Tap SAN-3102	1pc	
Power Cord	1pc	Bags(Behind the cabinet)
Fuse (10A)	1pc	
Hexagon socket head cap screws M10*55+ flat washer 10+spring washer 10	3 sets	
Hexagon wrench	1pc	
User Manual	1pc	Envelope(Behind the cabinet)
Inspection report	1pc	
Certification of quality	1pc	
Warranty Card	1pc	

BBS-V1800 Packing list

Items	Quantity	Position
Main body	1unit	Wood package
Base stand	1set	Paper package(Behind the cabinet)
UV Lamp(T6 30W)	1pc	
Gas Tap SAN-3102	1pc	
Power Cord	1pc	Bags(Behind the cabinet)
Fuse (10A)	1pc	
Hexagon socket head cap screws	3 sets	

M10*55+ flat washer 10+spring washer 10		Envelope(Behind the cabinet)
Hexagon wrench	1pc	
User Manual	1pc	
Inspection report	1pc	
Certification of quality	1pc	
Warranty Card	1pc	

1.3 Installation Conditions and Operating Environment

Laminar flow cabinet shall be placed in a protection area, workspace can not be right opposite to the door or window, and away from the outlet of air conditioning, prevent from the ventilation system, air conditioning, door, window, and personnel movement caused by the airflow impact on Laminar flow cabinet.

At least 300mm gap must be kept in the side and back side of the Laminar Air Flow for clean operating and for inspection.

Working environment:

- (1) Only applicable for indoor operation
- (2) Ambient temperature: 15° C ~35° C
- (3) Relative Humidity: ≤75%
- (4) Atmospheric pressure range: 70KPa~106KPa
- (5) Electrical parameters: Adequate power supply to the laminar flow cabinet(See 2.1.4 Technical Parameters)
- (6) Power supply need to be grounded; (Judging method: test the live wire and the neutral wire of the socket with multimeter. The voltage between live and ground should equal to the voltage of local electrical grid, and the voltage between neutral and ground should equal to 0. Otherwise the power supply is not grounded correctly)

1.4 Installation

- a. Remove all the packing materials
- b. Check the surface of main body to make sure there is no scratch, deformation or foreign bodies
- c. Confirm the complement of accessories according to the packing list
- d. Before removing the packing material, move the entire equipment to the place where it is going to be installed



The base stand will be packed at back of main body, please take it out before installation.

DO NOT INVERT, DISASSEMBLE OR TILT THE CABINET during transportation.

- e. Assemble the base stand with main body as shown in the picture

Please assembled base stand refer to Picture 4

Hexagon socket head cap screws M10*55+flat
washer 10+spring washer 10

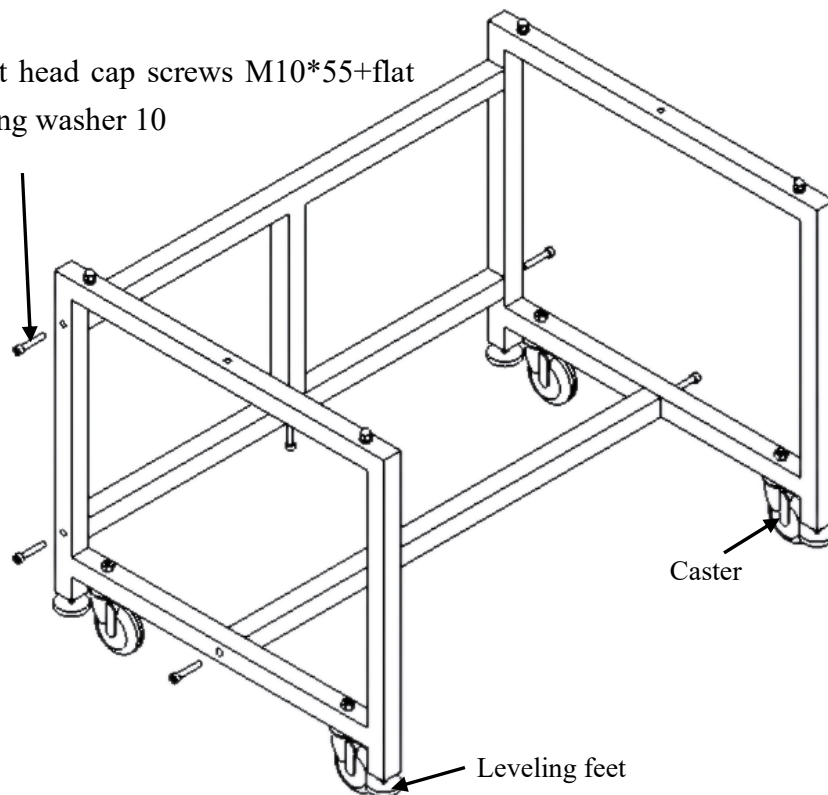

Picture 4

Removing Hexagon cylinder head bolt on both side lateral brace and T frame, the bottom of T frame, assemble referring to the picture, fasten the screw and Cap nut on the both side of base stand.

Foot height can be adjusted. Clockwise rotation of feet, when feet height is less than casters, the cabinet can be (or base stand) moved; anticlockwise rotation of feet, when feet height is greater than casters, then play a fixed role in preventing the cabinet (or base stand) from moving.



If you have any questions please contact engineers for commissioning

- f. connecting main body and base stand

Please connect main body and base stand refer to Picture 5

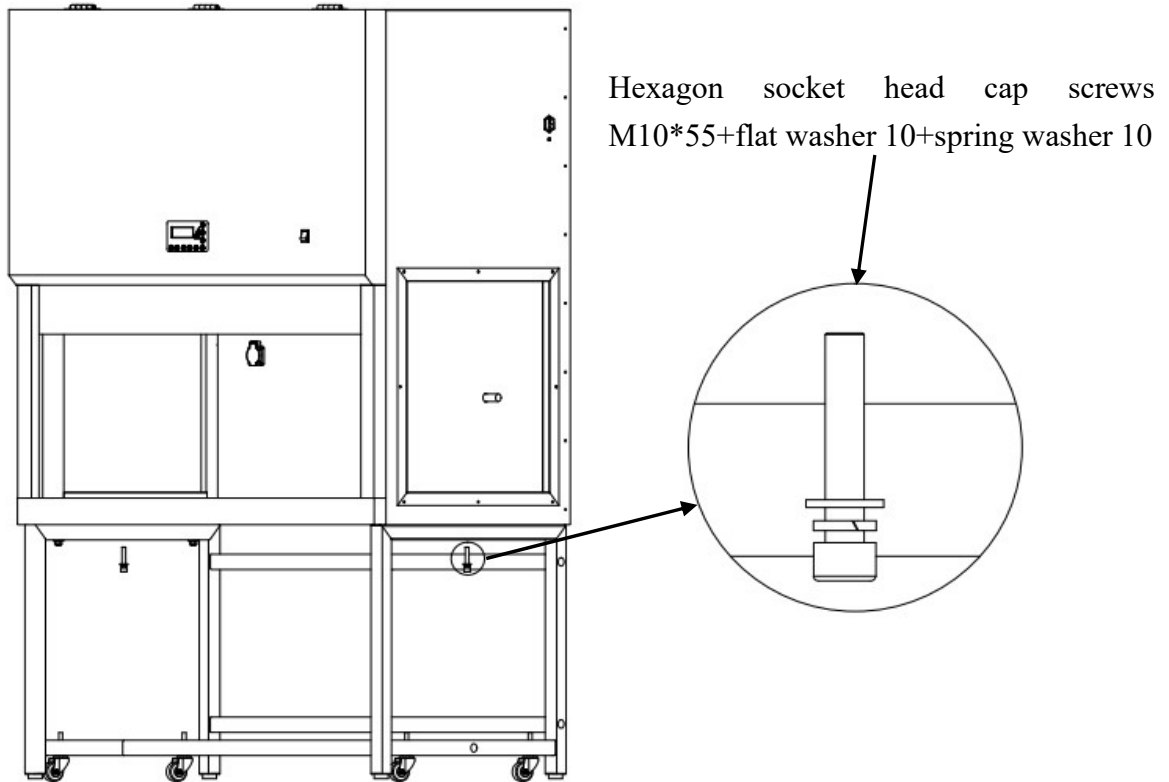

Picture 5

First, keep the main body above the base stand. (picture 5), then align the bolt of base stand. Mounting holes of the Main body at both sides, using Hexagon head bolt M10*55, flat washer 10, Spring washer 10 insert through base stand and the side panel and make them stable.

g. Pick up the gas (water) tap from accessory kit, first, unscrew the tap and nut, find the Mounting holes at the both side of cabinet glass. The Tap needs to be fixed as shown in the picture. The water mouth of the Tap should be inside the cabinet's operating zone, refer Picture 6, The other end of the Tap which is having threading on the pipe should be inserted through the glass hole, the threaded pipe should be fastened with washer and nut outside the glass and need to be tightened with a wrench. Please refer the below picture to carry out the tap fixing to the cabinet. See picture 6 and 7.

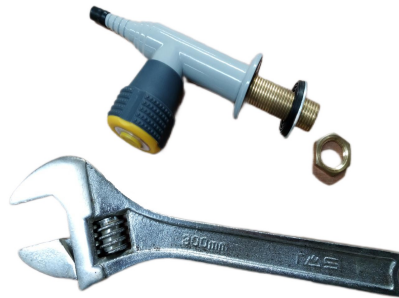

Picture 6



Picture7

h. After the above steps, move cabinet to the right cabinet position slightly, remove the power cord, check the power cord is intact. See picture 7.

1.5 Inspection after Installation

First, make sure the voltage and frequency to be same as nameplate showing, and then check the follows items with power on:

Checking Items	Normal working status
Fan motor	Running normally

Fluorescent lamp	Lamp lights up after pressing button
UV Lamp	Lamp lights up after pressing button
Screen buttons	All buttons work effectively
Socket	Use multimeter to test voltage output after pressing the socket button



If you have any questions please contact engineers to commissioning, Debugging methods in the service manual.

2. User Instructions

2.1 Functions

2.1.1 Product Concept

Laminar Flow Cabinet- LAF is used only for sample protection.

Laminar Flow Cabinet is a work bench or similar enclosure, which creates a particle-free working environment by taking air through a filtration system and exhausting it across a work surface in a laminar or unidirectional air stream. The laminar flow cabinet is enclosed on the sides and kept under constant positive pressure in order to prevent the infiltration of contaminated room air.

2.1.2 Works / airflow mode protection area

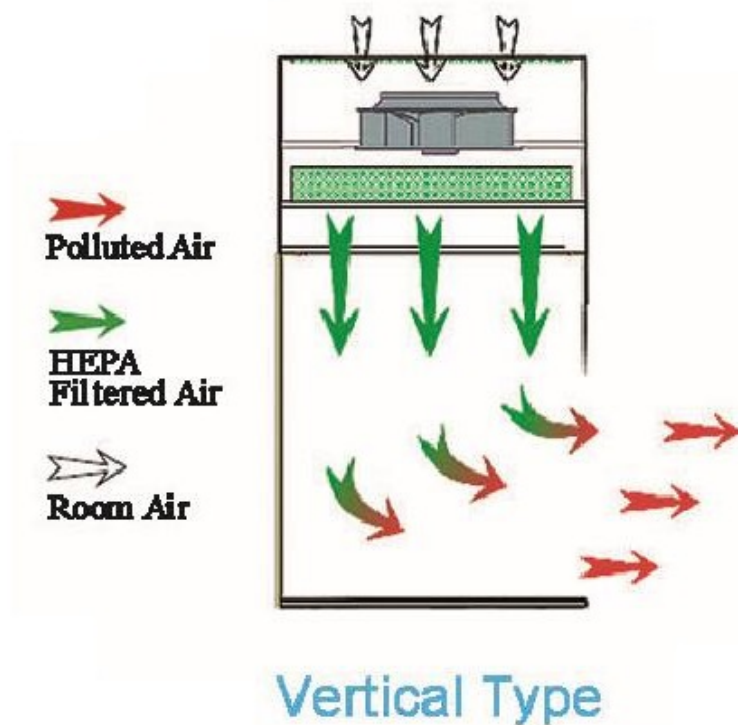

Picture 8

2.1.3 Protected objects

Laminar flow cabinet is to protect the experimental material, to create a local high cleanliness air environment, the main role is to ensure the accuracy of the operating area of the experiment, but for the environment and operators can't afford protection.

2.1.4 Technical Parameters

Model Parameters	BBS-V1300 <input type="checkbox"/>	BBS-V1800 <input type="checkbox"/>
External Size(W*D*H)	1310*750*2040 mm	1800*750*2040 mm
Working Zone Size(W*D*H)	1200*645*610 mm	1700*645*610 mm
Power Supply AC	220V±10% <input type="checkbox"/>	110V±10% <input type="checkbox"/>
Frequency	50 Hz <input type="checkbox"/>	60Hz <input type="checkbox"/>
Consumption	400W	450 W
Airflow velocity	0.3~0.5m/s	
UV Lamp Consumption	30W*1	40W*1
Fluorescent lamp	12W(LED)*1	16W(LED)*1
HEAP Filter	99.999% efficiency at 0.3µm	
Noise	<65dB	

Notes: We reserves the right to make changes in future product design, without reservation and without notification to its users.

1) Vibration amplitude

The net vibration amplitude between frequency 10Hz and 10KHz is no more than 5 µ m(rms).

2) Illumination

The average illumination is more than 350 lux.

3) Electrical properties

The cabinet would not breakdown in 5s when the voltage increases by 1390V (AC) within 5s.

Grounding resistance $\leq 0.1\Omega$.

2.2 Product Structure

2.2.1 Structural Composition of BBS-V1300/BBS-V1800

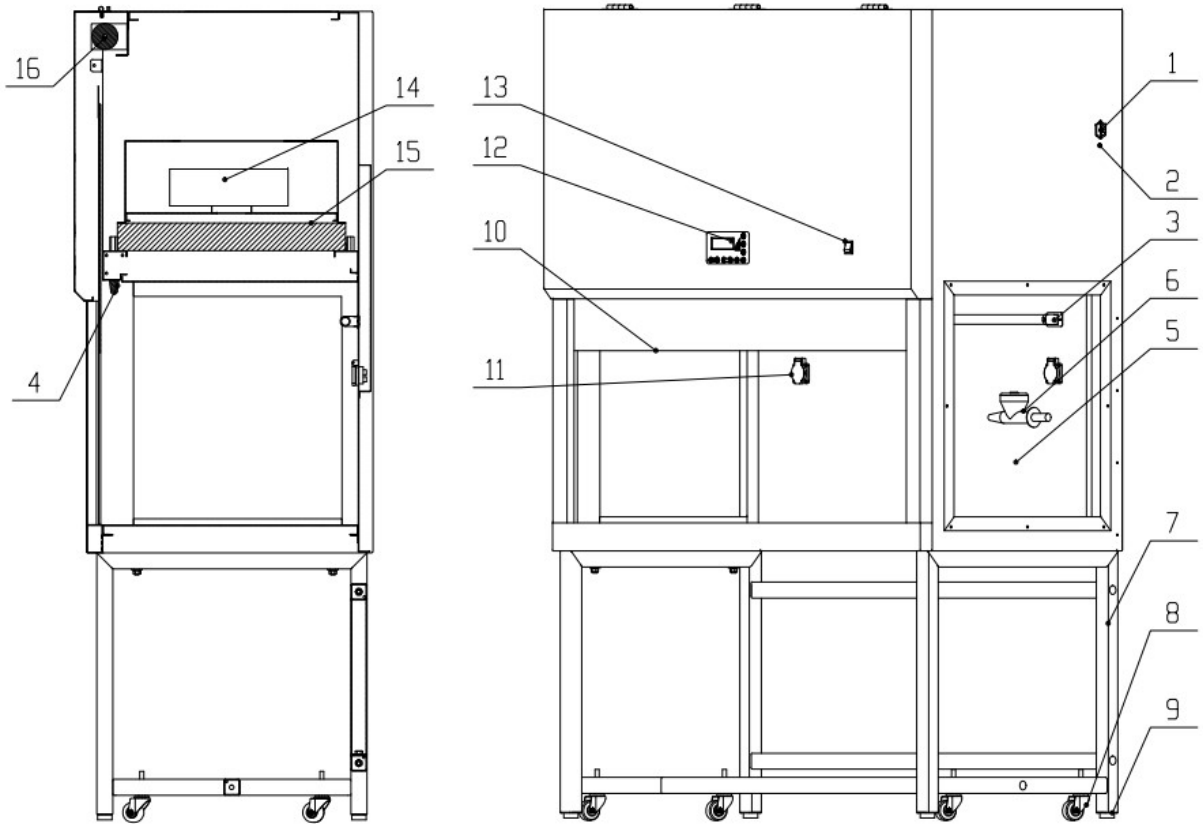

- | | | | |
|---|-------------------|----|--------------------|
| 1 | Power Socket | 9 | Leveling feet |
| 2 | Ground terminal | 10 | Front window |
| 3 | UV Lamp | 11 | Water-proof socket |
| 4 | LED lighting lamp | 12 | Control panel |
| 5 | Side glass window | 13 | Power switch |
| 6 | Gas Tap | 14 | Zero line fuse |
| 7 | Base Stand | 15 | HEPA filter |
| 8 | Caster | 16 | Tubular motor |

Picture 9

2.2.2 Structure Introduction

1) Driving system of front window

Driving system consists of tubular motor, front window, hauling mechanism and limit switch.

2) Air filtration system

Air filtration system is the core system of laminar flow cabinet. It consists of blower and HEPA filter system. The main function of air filtration system is to transfer filtered air to work area, ensure airflow velocity, and keep Class 100 cleanness of work area.

3) UV lamp

The UV lamp located at the top of the work zone effectively disinfects the entire work zone by emitting a wavelength of 253.7nm

4) Fluorescent light

The laminar flow cabinet is equipped with LED light, which ensures the standard requirement of average illumination is met.

5) Control Panel

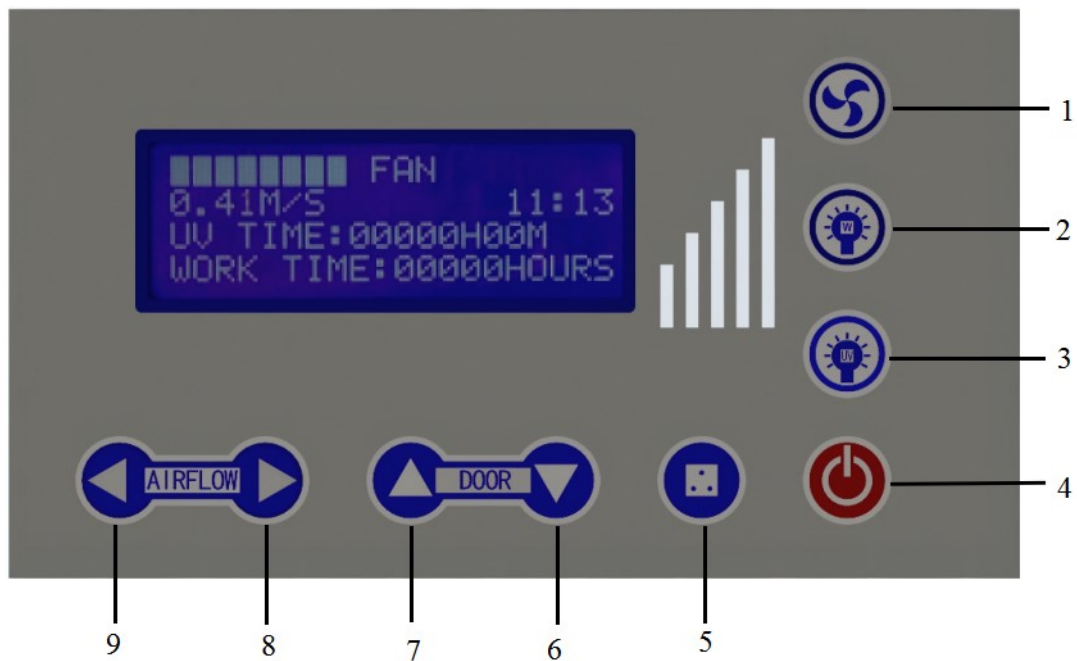

1	Blower	5	Socket
2	LED lamp	6	Glass window up
3	UV lamp	7	Glass window down
4	Power	8	Air volume decreases
9	Air volume increase		





Picture 10

a. Gear display

Working wind speed can be known by gear display.

b. Soft touch button



The main operation of the device can be carried out by touching button.

	<p>Power button</p>	<p>Press the power button, the equipment will switch between suspension mode and working mode.</p>
	<p>Fan button</p>	<p>To control fan working status. Fan has a memory function, that is, at the time of starting up the fan, it can display the gear when it was shut down last time, by which, there is no need to adjust the fan gear every time. (Note: It will not work when front window is fully closed)</p>
	<p>Lighting button</p>	<p>To control LED lamp.</p>
	<p>UV lamp button</p>	<p>To control UV lamp (UV lamp, fan, LED lamp and front window interlock; it won't work when LED lamp, fan and front window open) closed).</p>
	<p>Socket button</p>	<p>To control socket power status.</p>
	<p>Function setting debugging button</p>	<p>Press the glass Down button, glass window will fall down. Each time you press, the buzzer will sound; hold down this button, the glass window will continue to decline; release the button, the glass window will stop declining.</p>
	<p>Function setting debugging button</p>	<p>Press glass UP button, glass window will raise. Each time you press, the buzzer will sound ; hold down this button, glass window will continue to raise; release the button, the glass window will stop raising.</p>
	<p>Air flow adjustment button</p>	<p>To control fan speed increase. When fan is working, if ■ number is less than 8, each time you press, wind speed can increase a gear, and the buzzer rings once, until ■ ■ ■ ■ ■ ■ ■ ■ appears. Press this button when you use the UV lamp, UV lamp timing time increases, and the maximum time is 90 minutes, set time can be remembered.</p>

	<p style="text-align: center;">Air flow adjustment button</p>	<p>To control fan speed down. When fan is working, if ■ number is more than 1, each time you press, wind speed can reduce a gear, and the buzzer rings once, until one ■ appears. Press this button when you use the UV lamp, UV lamp timing time decreases, and the minimum time is 10 minutes, set time can be remembered.</p>
---	---	--

LCD display: When powered on, from top to bottom is ■ ■ ■ ■ ■ ■ ■ ■ ■ ■ FAN, It indicates the strength of blower wind speed; Shown below is the current state of the Winds; The right of the display is time; UV TIME, UV lamp working time; WORK TIME: HEPA filter working time.

Clock Adjustment: In standby mode, press light button continuously to enter clock setting mode after a buzzer alarm. Firstly, minute position is flashing, press UP and DOWN to adjust to present time. Then press the blower button switching to hour position and adjust to present time. After that, press the light button again, data will be saved after a buzzer alarm.

UV lamp timing: In standby mode, when the front window is lowered to a minimum, please press UV lamp control button , then the UV lamp is opened. After opening the UV lamp, the display will show the current status of the UV lamp timing: By pressing blower speed down button , the setting

time will be reduced one minute each time; by pressing blower speed up button , the setting time will get be increased one minute each time. You can set the time as needed (UV lamp timing range is 0-90 min, and the max factory setting is 90 min)

6) Motorized glass door control

The front window is motorized, with the touch of a button can be controlled freely.

7) Water proof socket

Waterproof socket is arranged in the operating area, to within the operating area of the power supply equipment and in the lighting lamp installing the front side plate (Picture 1) and when need to use a socket, open the equipment power supply, press the socket button (Picture 10), open the waterproof socket cover, access to electricity source plug.

 (1) Please make sure the total load of sockets should be $\leq 500W$;

(2) Waterproof socket is waterproof only when the front cover is down. When the front cover is opened, the socket can not be considered waterproof socket.

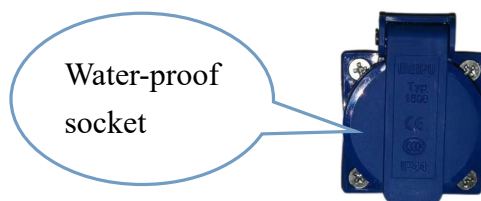

Picture11

8) Fuse

The equipment is equipped with main power fuse, They are located near the power cord's outlet. Fuse label is corresponding to the relevant specifications as shown in Picture 3.5.1. The replacement of fuse is showed in Picture 3.2.

9) Structure

- a) Cabinet body is built up of 1.2mm cold-rolled steel with anti-powder coating. Strong and steady.
- b) Work table is fully made up of 304 stainless steel which looks beautiful and has corrosion resistance performance.
- c) Base stand is made up of cold-rolled steel with anti-powder coating.
- d) Soft touch type control panel, beautiful appearance and easy handling.

2.3 Instructions for Operation

2.3.1 Normal Operation Notice

(1) Make sure input voltage is correct and stable. The rated load of main power socket should be higher than cabinet consumption. Plug must be well grounded.

(2) Moving principles of different samples inside cabinet: When two or more samples need to be moved, be sure that low-polluting samples move to high-polluting samples. Movement of items should also follow the principles of moving slowly and stably.

(3) The weight of items placed in the cabinet should not be more than 23Kg/25×25cm²;

(4) Avoid vibration: avoid using vibration equipment (e.g. centrifuge, vortex oscillator, etc.) inside the cabinet. The contamination might drop from the HEPA filter thus making the operation area cleanliness lower.

(5) No flame: An open flame would create turbulence which disrupts the pattern of HEPA-filtered air supplied to the work surface. If sterilization is required during the experiment, infrared sterilizer is highly recommended.

(6) HEPA filter life: With the usage time increasing, dust and bacteria accumulate within the HEPA filter, filter resistance is getting bigger, when it reaches the maximum point, the speed requirements can't be met then please contact our service department to get a new one. The used filter should be processed as medical waste.

(7) Please do NOT remove or loose the screws of those parts. To contact service personnel for special technical requirements.

(8) The maximum storage period is one year. If the period is more than one year, performance test should be done .



Serious declaration: we will take no responsibility for risks caused by improper operation and man-made damages!

2.3.2 Operation Process

- a. Connect to a suitable power supply
- b. Press relevant function keys (related keys, function and operation please refer to 2.2.2 description); check the function keys and the operation results are consistent, and according to the above technical parameters table to test whether the blower normal starts and wind speed is up to the standard requirements, fluorescent lamp and UV lamp is normal work.



UV lamp function could only be selected when front window is fully closed.

- c. The cabinet should be sterilized by UV lamp for at least 30 minutes with the window fully closed before any experiment.



(1) For safety of eyes and skin, people should leave the room during the UV sterilization.

(2) UV lamp should be checked regularly. It should be replaced when either the total working time reaches 600 hours or the intensity is lower than the requirement.

d. Please move up the front window at the suitable height above the work table and turn on the fan. Make sure the experiment should be started after fan working for at least 30 minutes.



For operating safety, please place the experiment materials inside the cabinet before experiment start.

After finishing the experiment, please fully close the front window and make sure to sterilize the cabinet by UV lamp for 30 minutes before turning off the cabinet.

2.4. Daily Maintenance

Preparations before maintenance: removal of items in the equipment

Preparation of goods: cotton or towel, concentrated soap, hot water, water, medical alcohol or other disinfectants, etc.

2.4.1 Clean the cabinet surface

Clean the surface of working zone

Wipe the entire surface with a soft cotton cloth which has been soaked with concentrated liquid soap. Afterwards, wipe off the foam with another cotton cloth or towel which has been soaked with clean hot/warm water. At the end, wipe the entire surface with a dry cotton cloth or towel rapidly.

For the contaminated or dirty work surface and sump, use 70% rubbing alcohol or other disinfectant to wipe.



Disinfectants used for wiping should not damage the 304 stainless steel.

2.4.2 Clean the external surface and front window

Use a piece of soft cotton cloth or towel with non-abrasive household cleanser to wipe the surface.

2.4.3 Overall maintenance period

The recommended interval period for comprehensive maintenance is either one year or 1000 working hours.

2.4.4 Maintenance methods

1) Daily or weekly maintenance

- a. Disinfect and clean the operating area;
- b. Clean the external surface and front window around the operating area (Refer to 2.4.1);
- c. Check the various functions of equipment (Refer to 2.4.2);
- d. Record down the maintenance result.

2) Monthly maintenance

- a. Clean external surface and front window (Refer to 2.4.2);
- b. Use towel with 70% rubbing alcohol or 1:100 dilution of household bleach(0.05% sodium hypochlorite) to wipe the working table, the inner face of front window and the inner wall surface of the working area(exclude the top wind grid). Use another towel with sterile water to wipe those area to erase the remain of chlorine;
- c. Check the various functions of the cabinet;
- d. Record down the maintenance result.

3) Annual maintenance

- a. Check the two lifting belt of the front window tubular motor, make sure both of them are well connected to the motor with same tightness.
- b. Check the UV lamp and LED light.
- c. Apply for overall performance test of the cabinet annually to ensure that the safety meets requirements. User is responsible for testing costs.
- d. Record down the maintenance result.



When doing maintenance, please pay attention to cut off the power, so as to avoid electric shock!

2.4.5 Storage conditions

Laminar flow cabinet should be stored in a warehouse with relative humidity no more than 75% and temperature lower than 40°C. The warehouse should have good ventilation performance without acid, alkali or other corrosive gases. Storage period shall not exceed one year. Safety cabinet stored for more than one year needs to be unpacked and checked before selling and using. Only the tested and qualified safety cabinet could be sold.

2.5 Replacement Parts List

BBS-V1300 replacement parts list

Number	Name	Specification
BS-01	Fuse	Φ5*20, 10A
BS-02	Lamp holder T8	LG13-01A
BS-03	UV Lamp	T6 30W
BS-04	LED holder T5	T5 12W
BS-05	UV lamp ballast	1*TL8-30W
BS-06	HEPA filter	1223*570*69mm
BS-07	Fan	FH320A, 3C certified
BS-08	Control panel	LCD control panel
BS-09	Front window glass	1223*640*5mm
BS-10	Side window glass 1	575*540.5*5mm(has hole)
BS-11	Side window glass 2	575*540.5*5mm
BS-12	Single wall gas tap	SAN-3102

BBS-V1800 replacement parts list

Number	Name	Specification
BT-01	Fuse	Φ5*20, 10A
BT-02	Lamp holder T8	LG13-01A
BT-03	UV Lamp	T6 30W
BT-04	LED holder T5	T5 16W
BT-05	UV lamp ballast	1*TL8-30W
BT-06	HEPA filter	1690*570*69mm
BT-07	Fan	FH320A, 3C certified
BT-08	Control panel	LCD control panel
BT-09	Front window glass	1723*640*5mm
BT-10	Side window glass 1	575*540.5*5mm(has hole)
BT-11	Side window glass 2	575*540.5*5mm
BT-12	Single wall gas tap	SAN-3102

2.6 Wiring Diagram (Picture12)

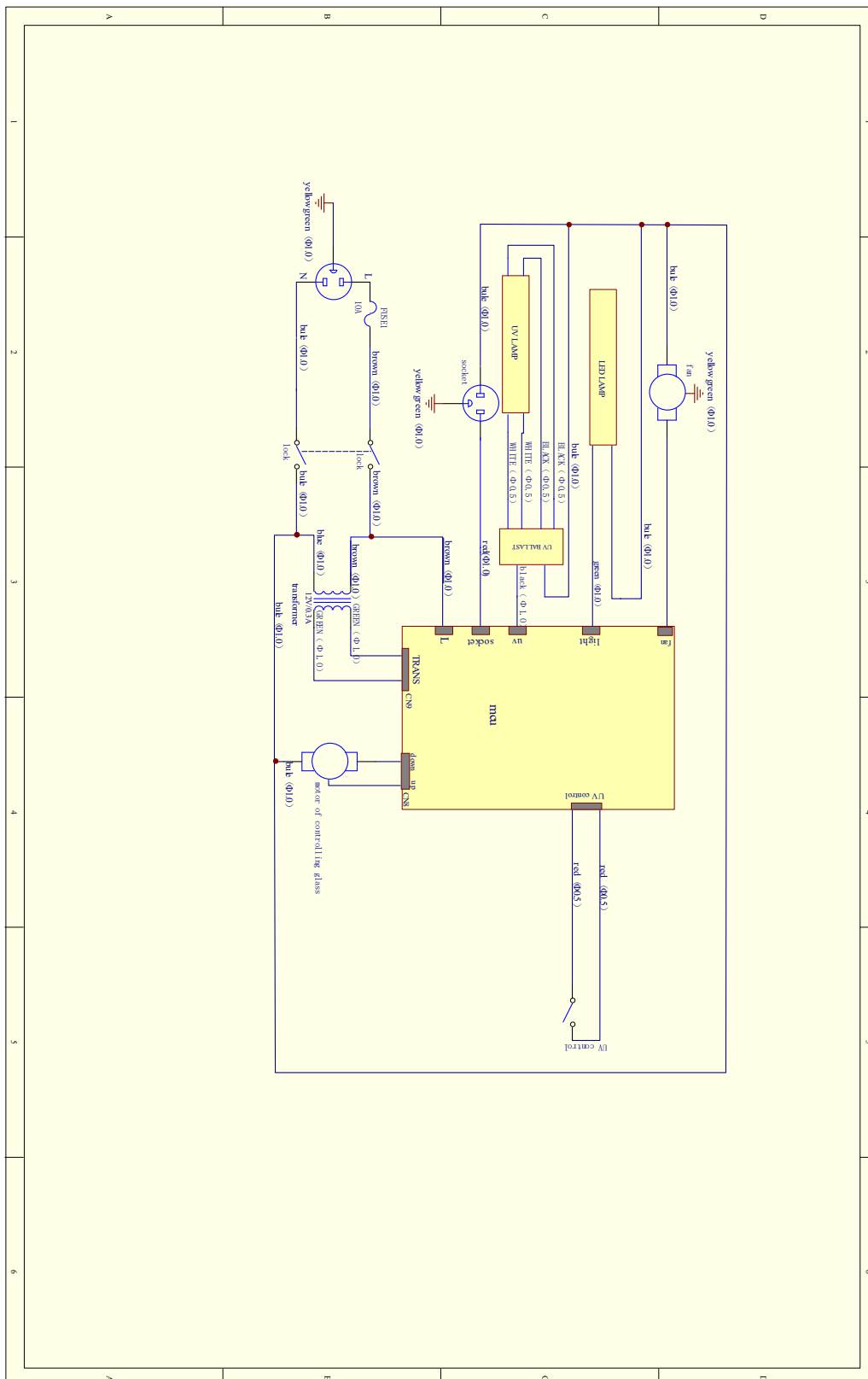

Picture12

3. Trouble Shooting and Solution

3.1 Trouble Shooting

Please confirm that the power is well connected, the cord is in good condition (without any damage) and the power lock is unlocked before trouble shooting the following problems.

Faults	Check parts	Measures
Fluorescent lamp doesn't work	LED holder plug	Connect the plug and holder tightly
	LED holder	Change it
	Circuit	Check circuit
	Control panel	Change it
UV lamp doesn't work	Interlock	Check the fluorescent lamp and the blower is open or not.
	Lamp holder	Tube and lamp holder is connected securely.
	Circuit	Check circuit
	Ballast	Change it
	UV lamp	Change it
	Micro Switch	Check if Micro Switch is broken
	Control panel	Change it
Button doesn't work	Control panel	Make sure the power connects well and the fuse is well
		Check if the button is broken
		Make sure the connecting wire is connected well
		Change control panel
Blower doesn't work	Micro Switch	Check if Micro Switch is broken or works fine
	Blower	If blower is broken, change it
	Circuit	Check circuit
	Control panel	Change it
No electricity in equipment	Power supply	Check power supply connects well
	Power wire	Check whether power wire has obvious
	Fuse	Check if the fuse is good
	Transformer	Check whether the transformer works
	Control panel	Change it

Display doesn't work	Connection winding	Connection winding displacement
	Display screen	Display screen
	Control panel	Change it



NOTES

- (1) The above trouble shooting methods should be done by qualified electricians under safe conditions(cut off power supply). Other components should not be removed. Risk caused by failing to follow those instructions would be responsible by user.
- (2) Please contact our technical department if a failure could not be traced or solved. Do NOT repair the equipment without a qualified electrician.
- (3) The trouble shooting and repair of this equipment only could be undertaken by trained and recognized technicians.
- (4) Please contact us or our agent technical department or agent to order required component or part. The model number and the serial number of purchased cabinet need to be indicated.

3.2 Replace the fuse

Fuse of waterproof socket is located at the right side of the cabinet. For replacing the fuse, turn off the power and disconnect the plug. Use a flathead screwdriver to unscrew the fuse holder. Replace the fuse inside the fuse holder and put it on back.

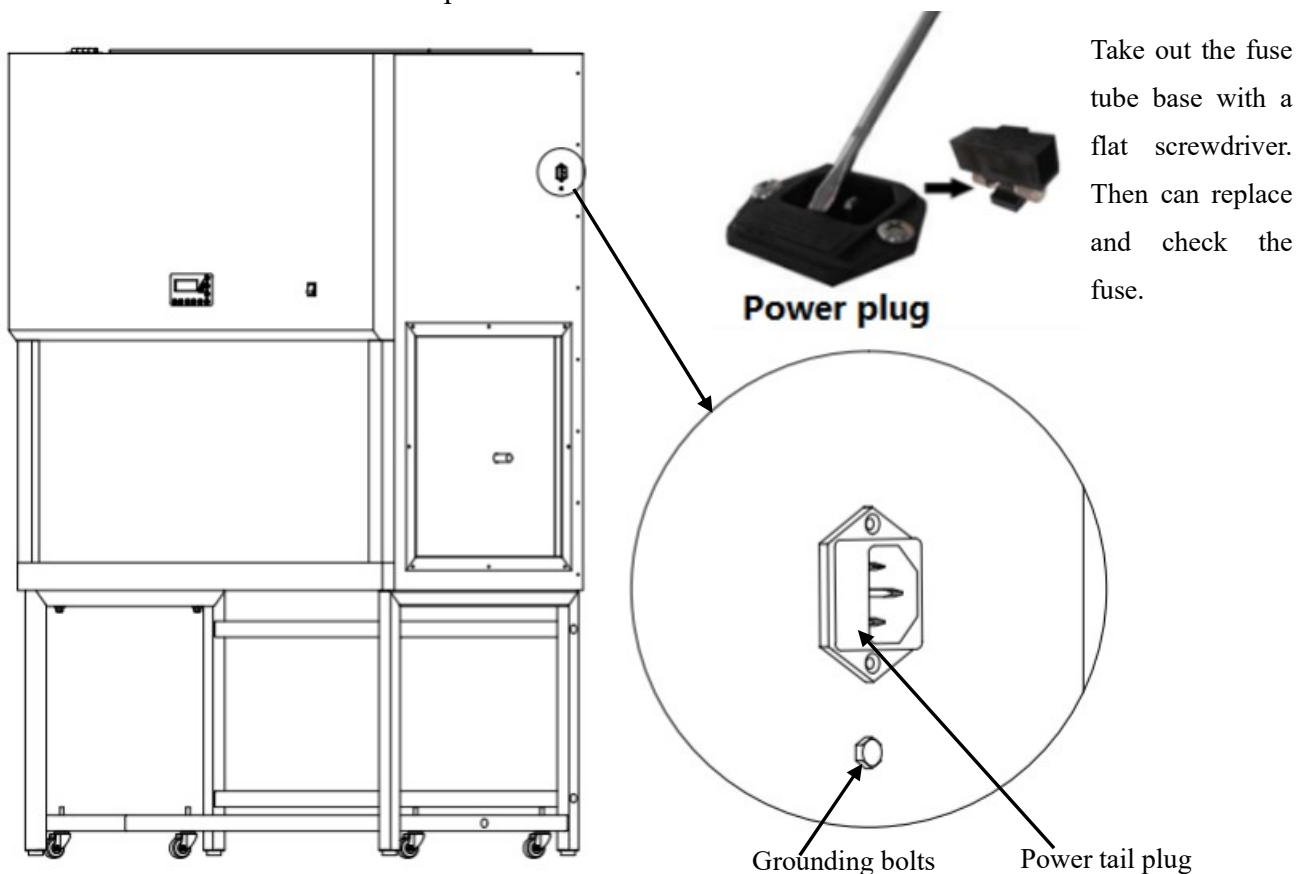

Picture 13

3.3 Replace fluorescent light

When the fluorescent light needs to be changed, turn off the power. Then remove the LED stand, unplug the right side, After replacing a new LED stand, inserted into the inclined slot.

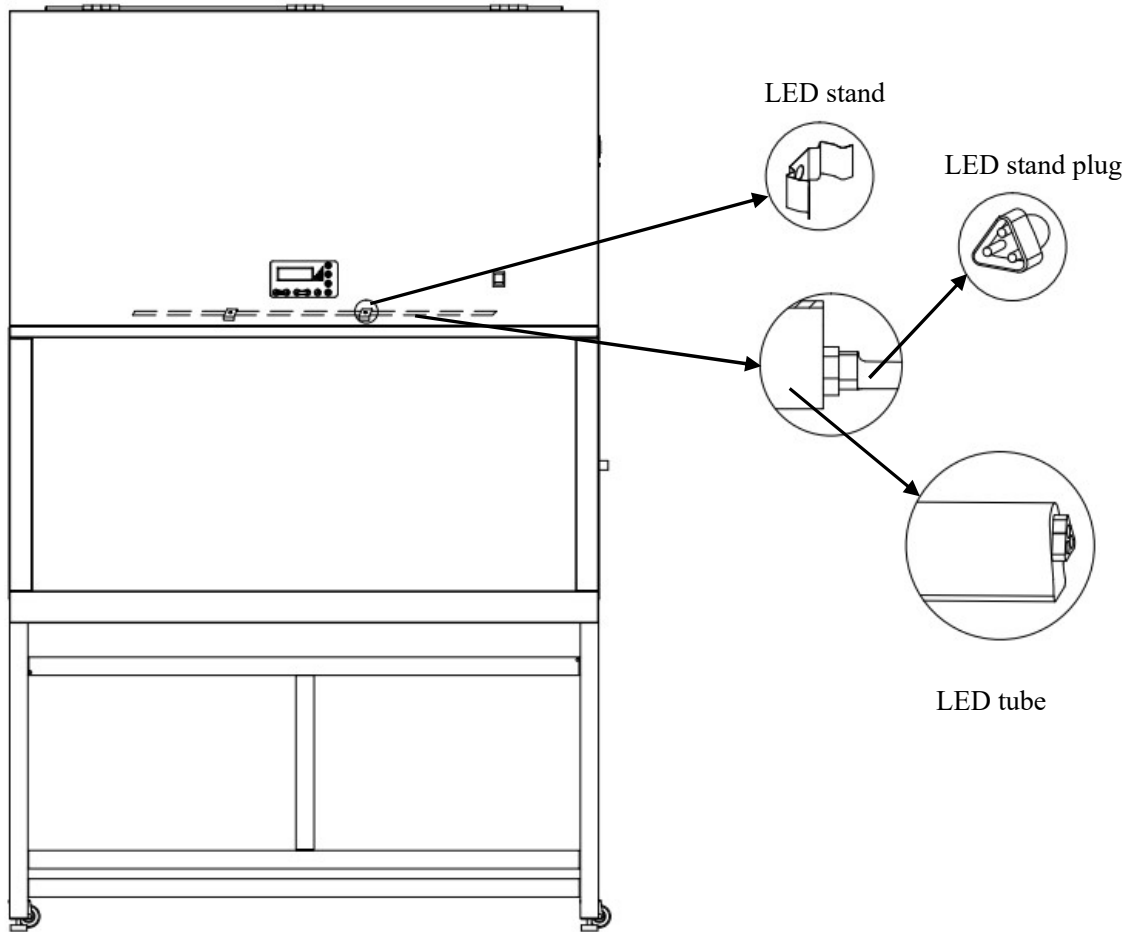

Picture 14

3.4 Replace the UV lamp

The UV lamp tube should change regularly, such as every 600 hours. For replacing the lamp tube, turn off the power and disconnect the plug. Rotate the tube for 90° to remove it and then install a new UV lamp tube by rotating in reverse direction. After replacing the UV lamp, the accumulated using time should be reset to zero by pressing and holding the UV button for 5 seconds. A buzz alarm would occur to indicate the reset.

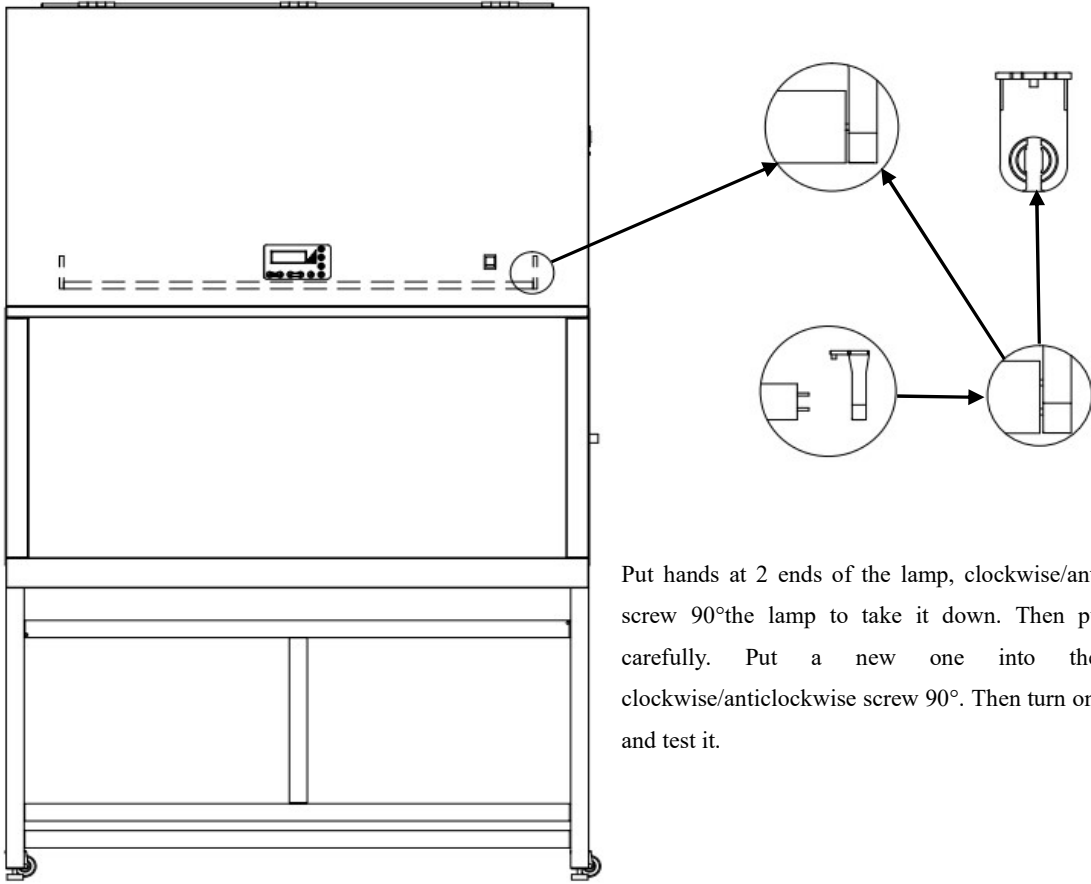

Put hands at 2 ends of the lamp, clockwise/anticlockwise screw 90° the lamp to take it down. Then put aside it carefully. Put a new one into the holder, clockwise/anticlockwise screw 90°. Then turn on the power and test it.

Picture 15

3.5 Label Description (Picture 16)

3.5.1 Fuse label



Picture 16

Note: 10A power fuse label

3.5.2 Ground label (Picture 17)



Picture 17

4. Warranty

- 1) Warranty is 12 months from EX-factory date (excluding consumable accessories: UV lamp, fluorescent lamp and fuse).
- 2) WE would not be liable for any repair of damage caused by improper operation.
- 3) If the warranty has been expired, We would still responsible for repair with relative charges.
- 4) Life time of laminar flow cabinet is 8 years from production date on the label.
- 5) We would provide equipment drawings and necessary technical data for maintenance companies or personnel trained by our engineers.

Warranty declaration: One-year Warranty, Life-long Maintenance