

**Fume Hood  
FH(X) Series  
User Manual**

**Version 2021.05**

---

## Preface

Thank you very much for purchasing our FH(X) series Fume Hood.

Please read the “Operating Instructions” and “Warranty” before operating this unit to assure proper operation. After reading these documents, be sure to store them securely together with the “Warranty” within touch for future reference.



Warning: Before operating the unit, be sure to read carefully and fully understand important warnings in the operating instructions.

---

# Content

Preface.....	1
Content.....	2
1. Unpacking, Installation and Debugging .....	4
1.1. Unpacking of Main Body.....	4
1.1.1. For wooden box .....	4
1.1.2. For carton box .....	6
1.2. Accessories Checking .....	7
1.3. Installation Conditions and Operating Environment .....	8
1.4. Installation.....	8
1.5. Inspection after Installation.....	12
2. User Instructions .....	13
2.1. Functions.....	13
2.2. Product Structure .....	15
2.3. Instructions of Operation .....	18
2.3.1. Normal Operation Notice.....	18
2.3.2. Operation Process .....	19
2.4. Regular Maintenance .....	20
2.4.1. Overall maintenance period .....	20
2.4.2. Preparation before maintenance.....	20
2.4.3. Clean the equipment surface.....	21
2.4.4. Maintenance methods .....	21
2.4.5. Storage conditions.....	21
2.5. Replacement Parts List .....	21
2.6. Wiring Diagram .....	24
3. Trouble Shooting and Labels .....	25
3.1. Common Failures and Solutions.....	25
3.1.1. Trouble shooting .....	25
3.1.2. Simple accessories replacement.....	26

---

3.2. Label Description.....	28
3.2.1. Fuse label .....	28
3.2.2. Ground label.....	28
4. Warranty .....	28

---

# 1. Unpacking, Installation and Debugging

Please firstly check whether the packing box is in good condition. If the packing box is damaged, please take photos and contact the freight carrier. LORDERAN and its dealers are not responsible for shipping damages

## 1.1. Unpacking of Main Body

Choose a proper unpacking method according to the actual situation.

1.1.1. For wooden box

a) Method 1 Necessary tools for unpacking: Electric drill with hexagon dead M8



Picture 1

b) Method 2 Use M8 wrench to unpack



Picture 2

The following diagram demonstrates quick unpacking procedures (Picture 3). Remove the screws shown in the diagram below, then move the wooden pieces to right and left.

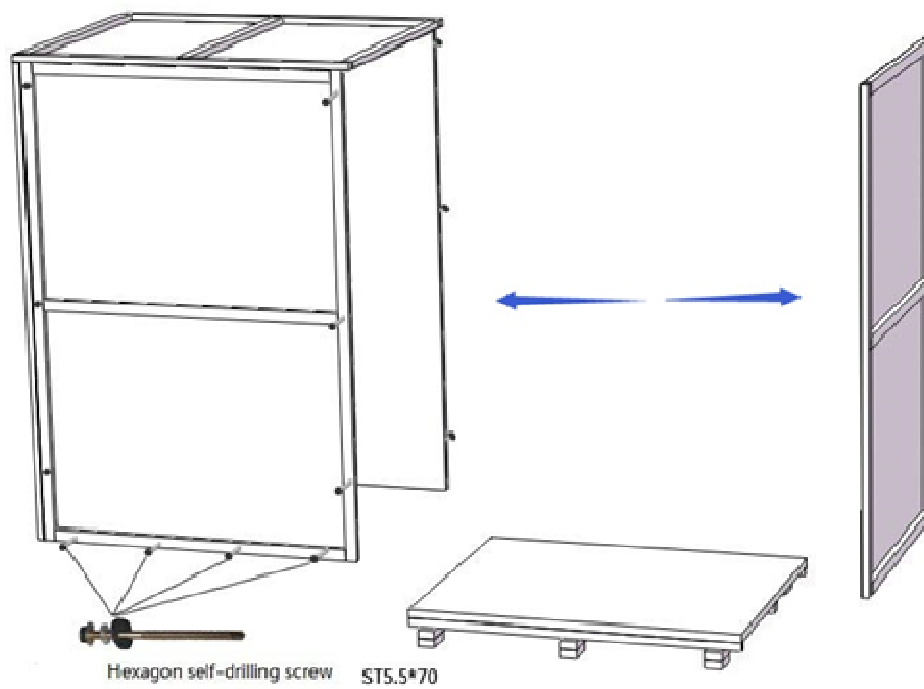

Picture 3

1.1.2. For carton box

Use scissor to cut the packing tape, take off the package cover, then move up the box body.



Picture 4

---

## 1.2. Accessories Checking

Accessories are placed inside the working area and base cabinet. Please take out all accessories and check the completeness referring to this packing list.

### Packing list (FH(X) Fume Hood)

Main body box:

No.	Items	Quantity
1	Main body	1 unit
2	Base stand	1 set
3	User manual	1 pc
4	Certification of quality	1 pc
5	Inspection report	1 pc
6	UV lamp	1 pc
7	Fuse (10A)	1 pc
8	Stainless steel hex cylinder head screw M10*55 Stainless steel flat washer10 Stainless steel spring washer 10	2 sets
9	PP small water sink and accessories	1 set
10	Water tap	1 pc
11	Gas tap	1 pc
12	Exhaust duct	1 pc
13	Duct clamp	1 pc
14	Foot Switch	1 pc
15	Power cord	1 pc
16	Motor control rod	1 pc
17	Allen wrench	1 pc



---

### 1.3. Installation Conditions and Operating Environment

#### 1.3.1. Location requirements

Fume hood installation location should avoid facing road and site that people pass frequently, avoid placing where the windows clogged and the lighting is insufficient, avoid placing where the entrance and the door affected, avoid placing opposite and in the corner of the wall.

- a) Only applicable to indoor operation
- b) Ambient temperature: 15°C~35°C
- c) Relative humidity: ≤75%
- d) Atmospheric pressure range: 70 kPa~106 kPa
- e) Electrical parameters: consistent with the rated voltage of the Fume Hood (See 2.1.4 Technical parameters)
- f) Power supply need to be grounded (Judging method: test the live wire and the neutral wire of the main socket with multimeter. The voltage between live and ground should equal to the voltage of local electrical grid, and the voltage between neutral and ground should equal to 0. Otherwise, the power supply is not grounded correctly.)

### 1.4. Installation

1.4.1. Remove all the package materials

1.4.2. Check the surface of the base cabinet and the main body to make sure there is no scratch, deformation or foreign bodies

1.4.3. According to the packing list of instruction, count carefully the accessories and materials

1.4.4. Position the base cabinet to the final location where an appropriate power supply is nearby. Move the whole equipment as close as possible to the final installation place

1.4.5. Make sure the voltage and frequency of power supply is same as the required value which is shown on the label. Press the “” button on the control panel to power on the equipment.

Afterwards, press the “” button to raise the front window, take out the accessories from the operating area and remove the work table as shown in the picture below, and then power off.

1.4.6. Connect base stand and main body

a) As shown in Picture 5, remove 6pcs six hex cylinder head screw thread M10\*55 from cross arm, fasten open frame 1, 3 of base stand and cross arm 2 tightly;

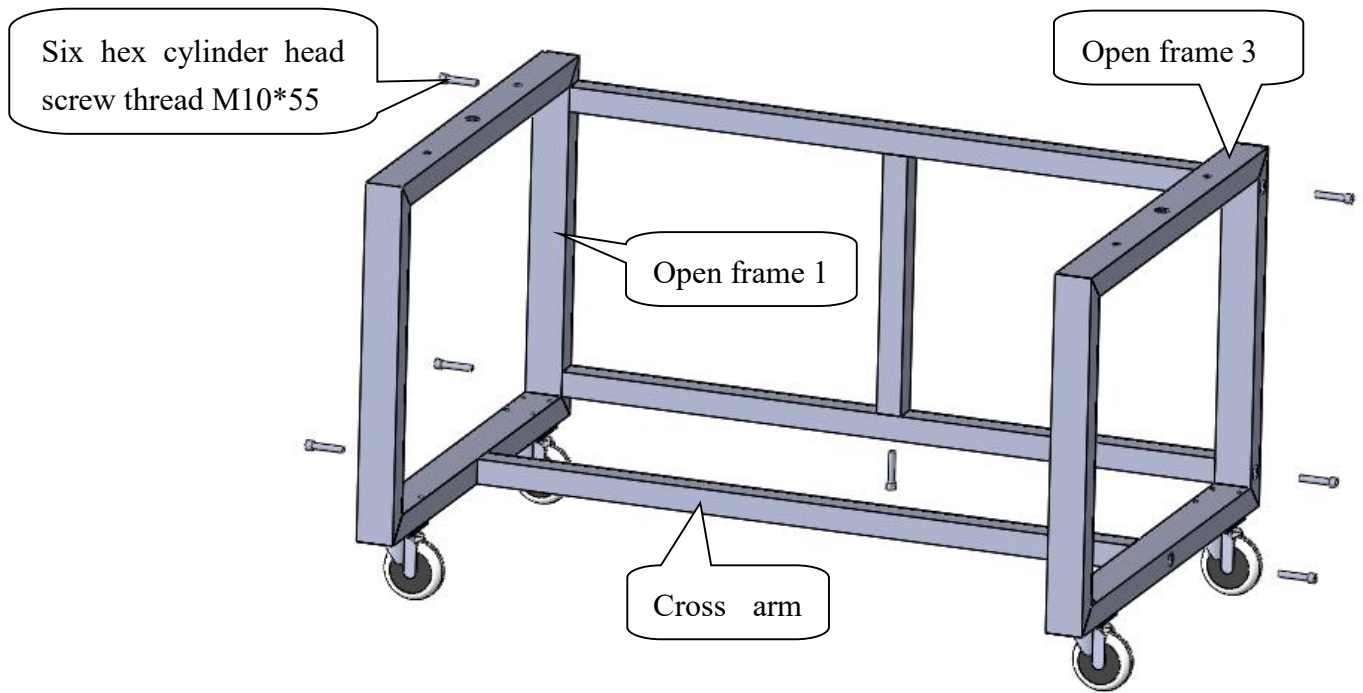

Picture 5

b)As shown in Picture 6, put base stand on empty position, open base stand and brake caster, put cabinet on right above base stand, then put it down, bolts on base stand embedded cabinet;

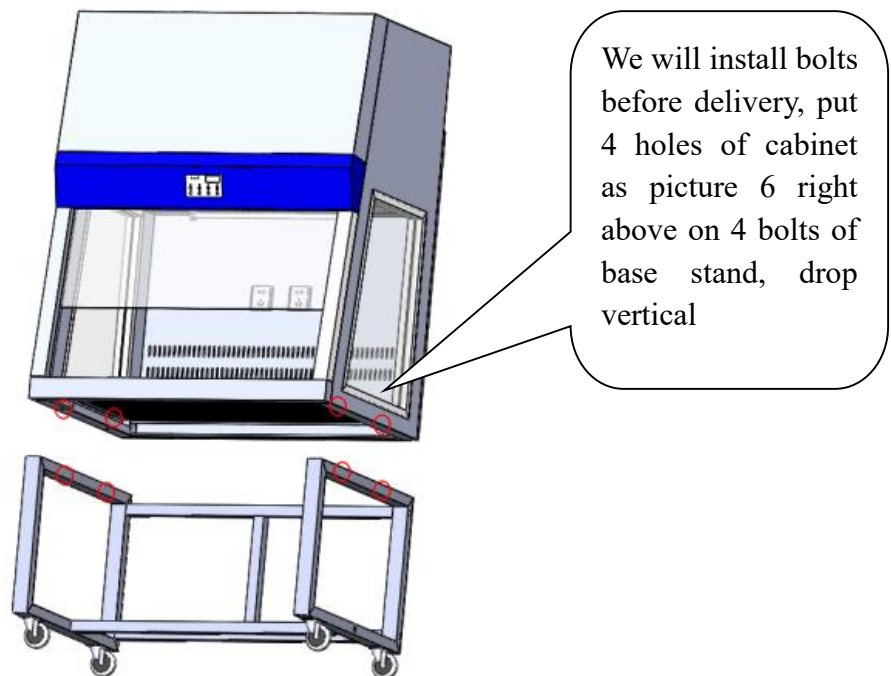

Picture6

c)As shown is Picture 7, take out 2pcs stainless steel hex cylinder head screw M10\*55,2pcs stainless steel flat washer10 and 2pcs stainless steel spring washer 10 pass base stand, fasten cabinet and base stand tightly;

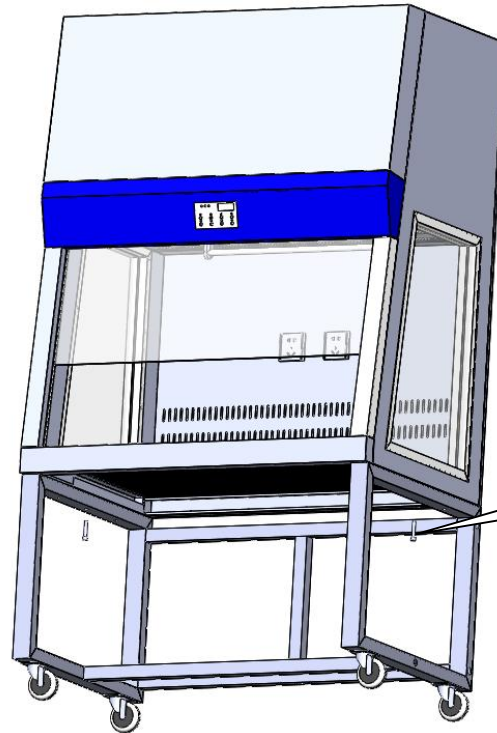

Picture 7

1.4.7. Installation of water tap and gas tap

Place the work table, install gas tap to side glass window as picture 8, install the water gas and water sink on the work table as picture 9, take out foot switch, insert power cord ends to terminal of foot switch as picture 10, using duct clamp to connect one side of exhaust duct with cabinet, connect another side to outside as picture 11, then finish the installation;



Picture 8

Gas tap(remove hex nut of gas tap, gas tap pass from inner work area to side window glass hole towards the right ,then using hex nut fasten tightly and connect gas pipe)

Water tap(remove hex nut of water gas, pass work table from inner work area to bottom, then using hex nut fasten tightly and connect water pipe)



Picture 9

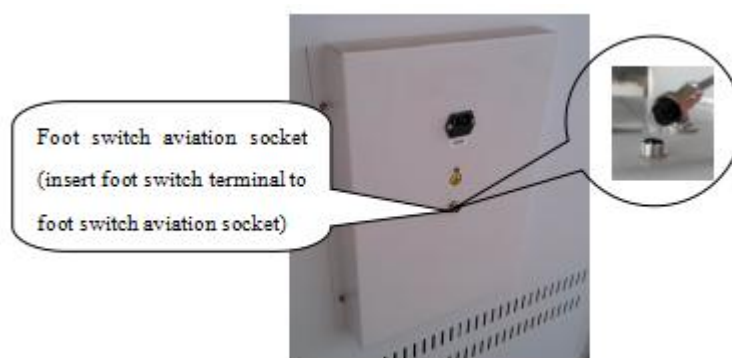

Picture 10

#### 1.4.8. Installation of exhaust duct

Take out the duct clamp and the exhaust duct. Put the clamp on the exhaust duct and then connect the exhaust duct with the air exhaust outlet on top of the Fume Hood. Afterwards, use Slotted screwdriver to fasten the duct clamp firmly. The other end of the exhaust duct should be fixed outside the laboratory room and in the open air.

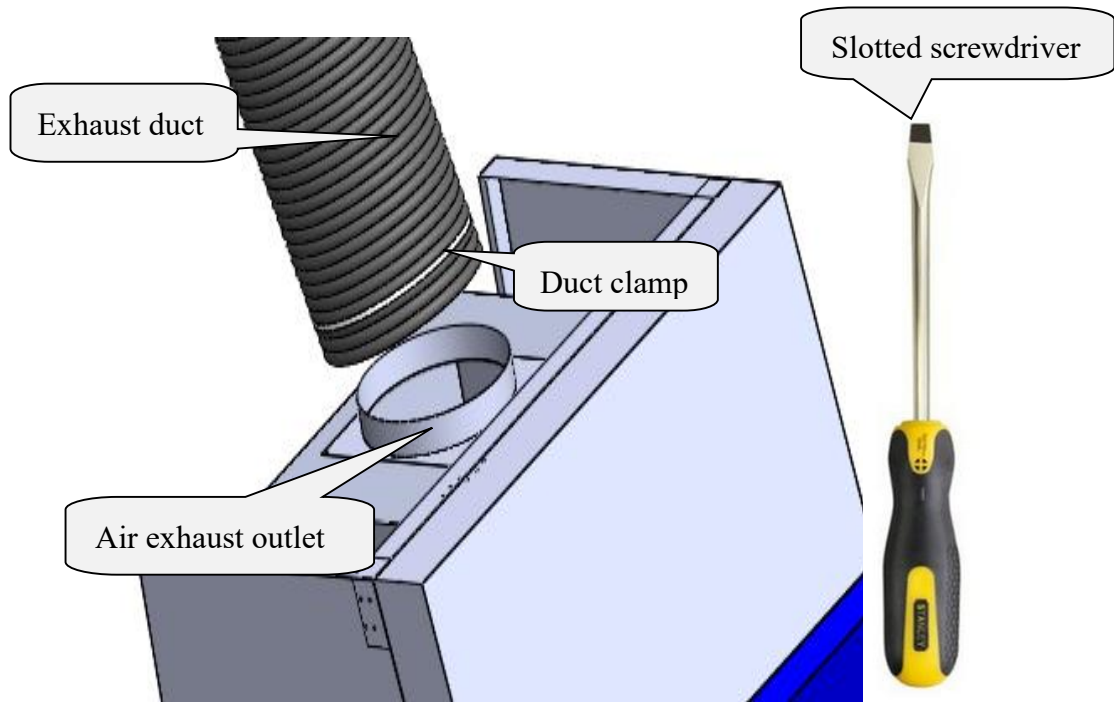

Picture 11

### 1.5. Inspection after Installation

Refer to this table and follow the instruction in 2.3.2, check the following items after powering on the Fume Hood.

Checking Items	Normal working status
Power status	Equipment could be powered on/switched off when press the power button
Fan	Runs normally after pressing the Fan button; speed could be adjusted by pressing the adjusting button
Front window	Front window could be moved smoothly by pressing the UP and DOWN buttons
Fluorescent lamp	Lamp lights up after pressing button
UV Lamp	Lamp lights up after pressing button
Socket	Use multimeter to test voltage output after pressing the socket button
Foot switch	Front window rise by pressing red switch, down by pressing black switch.

---

**⚠️ NOTE:** Please contact Lorderan technical department or agent for inspection or trouble shooting when problems could not be solved. Methodology of trouble shooting is stated in the After-sale Service Manual.

## 2. User Instructions

### 2.1. Functions

#### 2.1.1. Product concept

This product belongs to FH(X) series Fume Hood. Fume Hood is a kind of negative pressure ventilation system for protecting operator and laboratory environment. Room air flows inward from the front opening of the Fume Hood and is consistently ventilated by the extract blower. Therefore, contaminated fumes, vapors, toxic gasses, aerosol and corrosive substance which are probably generated during experiments could be prevented from spreading to the operator or into the laboratory room. In addition, the polluted air could be purified by the active carbon filter before exhausting through the duct. Thus, the outdoor environment could also be protected.

**⚠️ NOTE:** Experiments with the use of flammable, explosive substances and strong acids or bases should NOT be conducted by this FH(X) series Fume Hood.

#### 2.1.2. Operating principle/air flow pattern

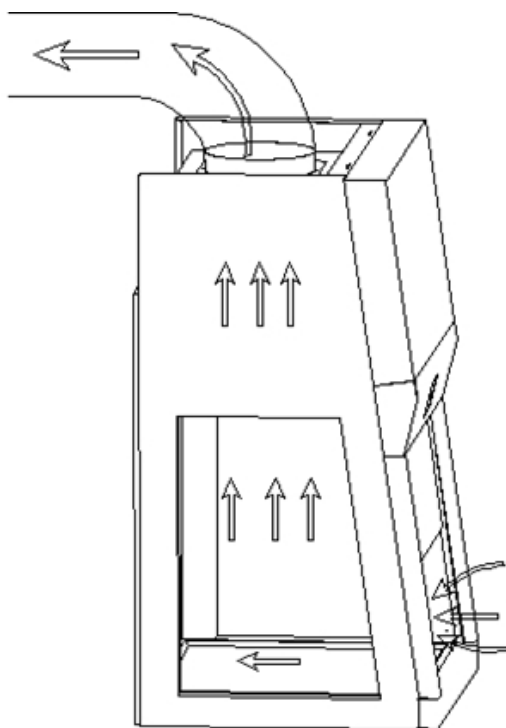

Picture 12

#### 2.1.3. Protected object

The primary goal of the Fume Hood is to protect operators and laboratory environment from exposure to infectious aerosol and toxic fumes which may be generated from the reaction during experiments.

### 2.1.4. Technical parameters

Model Parameter	FH1000(X) <input type="checkbox"/>	FH1200(X) <input type="checkbox"/>	FH1500(X) <input type="checkbox"/>	FH1800(X) <input type="checkbox"/>
Rated Voltage AC	220V±10% <input type="checkbox"/>		110V±10% <input type="checkbox"/>	
Rated Frequency	50 Hz <input type="checkbox"/>		60Hz <input type="checkbox"/>	
External Dimension (W*D*H) mm	1000*840*2150 mm	1200*840*2150 mm	1500*840*2150 mm	1800*840*2150 mm
Working Zone Dimension (W*D*H) mm	880*730*745 mm	1080*730*745 mm	1380*730*745 mm	1680*730*745mm
Power Supply Consumption	400 W	400 W	500 W	500 W
Inflow Velocity	0.3~0.8m/s			
Max Opening	520mm			
UV Lamp Consumption	20W	20W	30W	30W
Fluorescent Lamp Consumption	T5 8W	T5 12W	T5 16W	T5 16W
Noise	≤68dB(A)			



**NOTE:** a) Power supply consumption includes the consumption loaded at working zone, which should not exceed 500W.

b) Lorderan reserves the right to make changes in future product design, without reservation and without notification to its users.

### 2.1.5. Performance index

a) Vibration amplitude

The net vibration amplitude, at a range of frequency from 10 Hz to 10 KHz, would not exceed 5 μm (rms)

b) Electrical performance

---

Dielectric Withstand Test: the Fume Hood would not breakdown in 5s when the voltage increases by 1390V (AC) within 5s  
Ground resistance  $\leq 0.1\Omega$

## 2.2. Product Structure

### 2.2.1. Structural composition of FH (X) Series Fume Hood

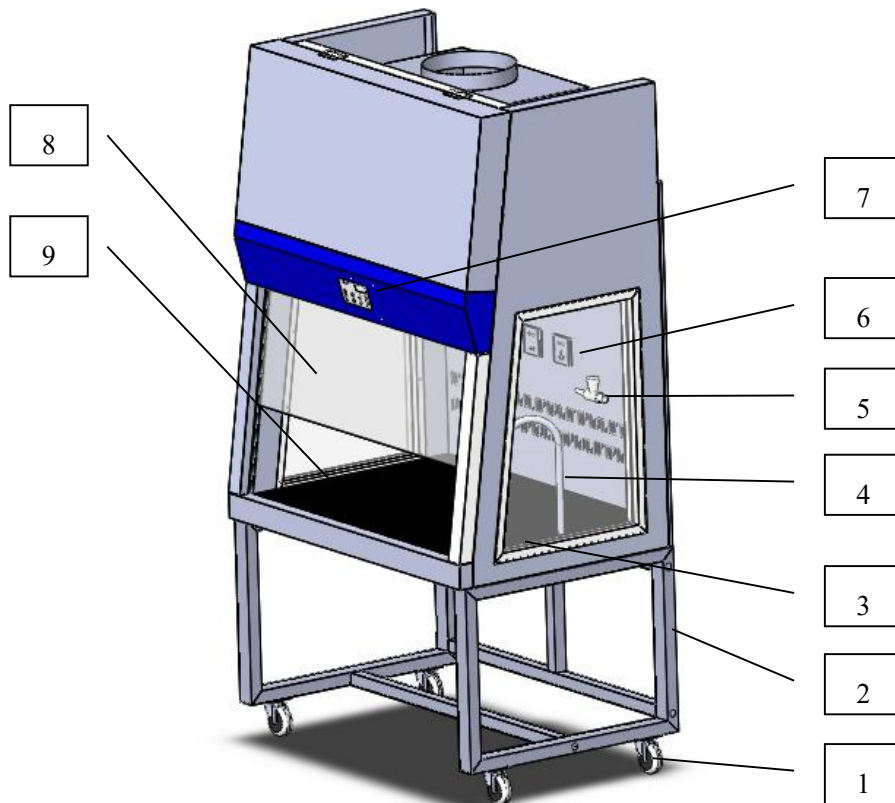



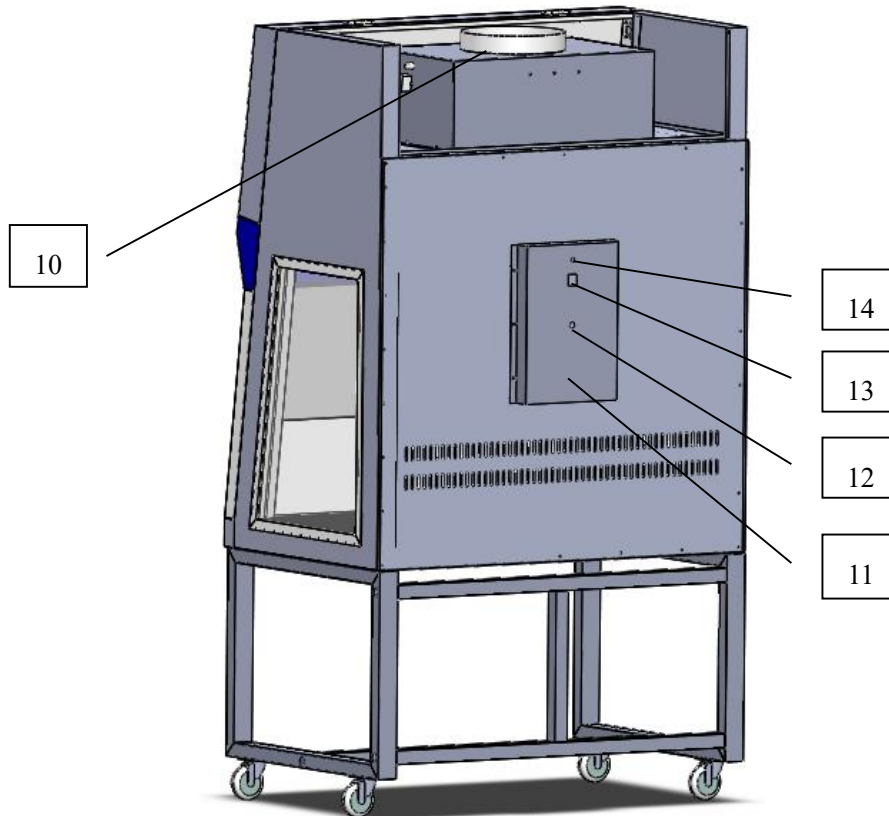

Picture 13

- |                  |                              |
|------------------|------------------------------|
| 1. Caster        | 8. Front window              |
| 2. Base stand    | 9. Work table                |
| 3. Water sink    | 10. Exhaust outlet           |
| 4. Water tap     | 11. Circuit protection board |
| 5. Gas tap       | 12. Foot switch socket       |
| 6. Socket        | 13. Socket                   |
| 7. Control panel | 14. Earthing bolt            |

### 2.2.2. Structure introduction

#### a) Driving system of front window

Driving system consists of tubular motor, front window and hauling mechanism (hauling sash)

#### b) UV lamp

The entire work zone could be sterilized effectively by the UV lamp located at the top of work zone. Emission of 253.7 nanometers could ensure the most efficient decontamination.

#### c) Fluorescent light

Lighting using LED fluorescent lamp, to ensure that the operating zone average illuminance is accord with a standard to ask.





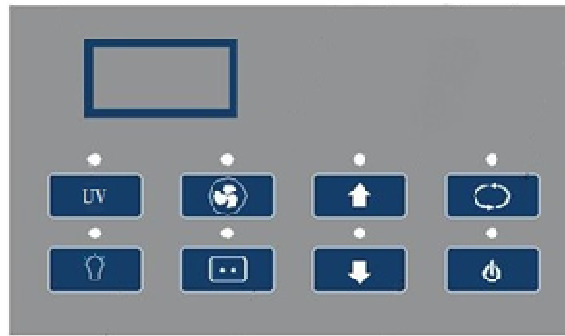

**NOTE: a) Please make sure the total load of sockets should be  $\leq$  500W.**

#### d) Control Panel

There are totally 8 common buttons on the control panel (refer to Picture 14). UV lamp, Fluorescent lamp, Blower (Fan), Adjust fan speed, Front window up, Front window down, Socket power, Power button.



Picture 14

-  Power button, the main switch of the Fume Hood
-  Adjust fan speed, press to adjust the speed of the blower (fan) from F1 to F9. When it is F9, press this button again, it will return to F1.
-  Front window up, press and hold to continuously raise the window.
-  Front window down, press and hold to continuously lower the window.



Blower (Fan), press to turn on the blower, interlocked with UV lamp.



Socket power, press to activate the sockets in the working zone. Socket, located at the left side under the front opening, could supply electricity power for devices used in experiments and could be controlled by the button.



UV lamp, only works when both the blower and the fluorescent lamp are turned off.



Fluorescent lamp, press to turn on the light, interlocked with UV lamp

★Socket: Power supply consumption includes the consumption loaded at working zone, which should not exceed 500W.

★Fuse

The fuse is installed in the rear of the product, the corresponding socket is equipped with a fuse, fuse specifications are same to the fuse label contents. Replace it according to corresponding label content.

★Foot switch



Picture 15

Foot switch air socket located in the rear of the cabinet, The terminal insert foot switch air socket, Press the red switch on the left, lifting the glass door, Press the black switch on the right lowered the glass door.

★Structure

- i. External case body adopted 1.2 mm cold-rolled steel in double layer structure with electrostatic coating and rust-proof treatment.
- ii. Inner wall of work area is fully made of Phenolic Compact Laminate which provides corrosion resistance as well as attractive appearance; work table is made of solid chemical resistant laminate which is easy to clean and wash.
- iii. Fume hood front window adopted 5 mm toughened glass.
- iv. Control panel adopted soft-touch buttons and microprocessor control system that make the operation easily to be controlled
- v. The electronic control system could prevent overload of the circuit and electric shock, stabilize the performance, protect the equipment and extend the use life of the Fume Hood.
- vi. The sockets (at working zone) adopted non-flammable PC material that is specialized for laboratory use

## 2.3. Instructions of Operation



### 2.3.1. Normal Operation Notice

- 
- a) Make sure input voltage is correct and stable. The rated load of main power socket should be higher than cabinet consumption. Plug must be well grounded.
  - b) The equipment should be powered off and unplugged before doing any replacement of parts, such as UV lamp and fluorescent lamp.
  - c) The front window is made of explosion-proof toughened glass. In order to keep the front window clean and clear, please wipe it by wet soft cloth and keep it away from hydrofluoric acid
  - d) The air deflector and other internal accessories should be cleaned according to the use of the Fume Hood
  - e) The air duct and the blower of the Fume Hood should be cleaned and maintained regularly in a proper way
  - f) Fume Hood should be placed in a position where there should be no other equipment or machine within 150mm of the front window
  - g) Do NOT place any soft or tiny materials (such as soft tissue) on the work table during the operation to prevent breakdown of the blower causing by sucking those materials
  - h) The packed Fume Hood should be stored in a warehouse with relative humidity no more than 75% and temperature lower than 40°C. The warehouse should have good ventilation performance without acid, alkali or other corrosive gases
  - i) The maximum storage period is one year. A performance inspection should be done if the storage period exceeds one year





**NOTE: LORDERAN WILL NOT BE LIABLE FOR ANY RISK OR DAMAGE ARISING FROM YOUR FAILURE TO APPROPRIATELY OPERATION THE FUME HOOD!**

### 2.3.2. Operation Process

- a) Connect to a suitable power supply
- b) Power on the Fume Hood by pressing the power switch under the working zone, the LED screen would be lighted as “”
- c) Press the POWER button  on the control panel to enable all functions (fluorescent lamp, UV lamp, blower, socket, front window). The LED screen would display the accumulated operating time of the blower and the accumulated operating time of the active carbon filter.





**NOTE: The displayed figure needs to multiply by 10 to get the actual operating time. The unit is hour.**

- d) Press the UP button  to raise the front window to a proper height. Please refer to 2.1.4 for the maximum opening of the front window
- e) Press the FAN button  to turn on the blower. The LED screen would display the speed level of the fan memorized from the last time of operation. The indicator light above the FAN button would be turned on to show the working status of the blower. Make sure the blower runs at least FIVE minutes before starting any experiment.



**NOTE: The blower would be turned off automatically when the UV lamp is turned on.**

- f) Press the LAMP button  to turn on the fluorescent light. The indicator light above the button would be turned on to show the working status of the fluorescent light. Please refer to the actual condition of illumination in the laboratory room to decide whether the fluorescent light is needed.
- g) After finishing the experiment, turn off the blower and the fluorescent light and press the DOWN button  to close the front window
- h) Press the UV button  to turn on the UV light. The indicator light above the button would be turned on to show the working status of the UV lamp. Please make sure the sterilization is at least 30 minutes. Press the UV button again to turn off the UV lamp. Please refer to the actual situation to decide whether sterilization is needed. Only shut down the blower and fluorescent lamp, can UV lamp be turned on.



**NOTE: a) When the UV light is in working status, people should leave the room in order to protect skin and eyes.**

**b) UV lamp should be replaced regularly according to the frequency of use. The service life of UV lamp is about 600 hours.**

- i) Press the POWER button  to power off the Fume Hood after all functions have been turned off. Press the power switch to disconnect power before plugging out.
- j) If power failure happened during the operation causing by interruption of electricity supply or dropping off of plug or other abnormal situations, the equipment could memorized the current operating status automatically and resume those functions when power on again.

## 2.4. Regular Maintenance

A detailed daily record of operating time is recommended, as the accumulated using time will directly affect the plan of maintenance.



**NOTE: a) To avoid electric shock, please cut off ALL power before applying maintenance for the equipment!**

**b) The blower and the exhaust duct should be inspected and maintained regularly.**

**c) The accumulated operating time is a vital factor of deciding when the maintenance is needed. A comprehensive record of operation is highly recommended to be taken down after each time of operating.**

### 2.4.1. Overall maintenance period

Comprehensive maintenance is recommended to be carried out for a period of 1000 working hours or one year; weekly and monthly maintenance is also required to optimize the performance of the Fume Hood.

### 2.4.2. Preparation before maintenance

---

Material needed: soap, hot water or warm water, a piece of soft cotton cloth, a piece of dry cloth or towel, rubbing alcohol or other disinfectants, 1:100 dilution of household bleach, abrasive household cleaners, sterile water.

#### 2.4.3. Clean the equipment surface

##### a) Clean the surface of working zone

Wipe the entire surface with a soft cotton cloth which has been soaked with concentrated liquid soap. Afterwards, wipe off the foam with another cotton cloth or towel which has been soaked with clean hot/warm water. At the end, wipe the entire surface with a dry cotton cloth or towel rapidly. Do not spray any chemical reagents on the operator panel or other labels to prevent discoloration or discoloration of the label film.

For the contaminated or dirty work surface and sump, use 70% rubbing alcohol or other disinfectant to wipe.



**NOTE: Disinfectants used for wiping should not damage the 304 stainless steel.**

##### b) Clean the external surface and front window

Use a piece of soft cotton cloth or towel with non-abrasive household cleanser to wipe the surface.

#### 2.4.4. Maintenance methods

##### a) Weekly and monthly maintenance

- i. Clean the external surface and front window (refer to 2.5.3.b)
- ii. Check the various functions of the Fume Hood
- iii. Record down the maintenance result

##### b) Annual maintenance

- i. Check the two lifting belt (sash) of the front window tubular motor, make sure both of them are well connected to the motor with same tightness
- ii. Check the UV lamp and fluorescent lamp, replace it if needed
- iii. Apply for overall performance test of the cabinet annually to ensure that the safety performance has met the requirements. User is responsible for testing costs
- iv. Record down the maintenance result

#### 2.4.5. Storage conditions

Fume Hood should be stored in a warehouse with relative humidity no more than 75% and temperature lower than 40°C. The warehouse should have good ventilation performance without acid, alkali or other corrosive gases. Storage period shall not exceed one year. Fume Hood stored for more than one year needs to be unpacked and checked before selling and using. Only the tested and qualified safety cabinet could be sold.

## 2.5. Replacement Parts List

**FH1000(X) Fume Hood Replacement Part List**

<b>NO.</b>	<b>Part Name</b>	<b>Specification</b>
J101	Fuse tube	10A
J102	UV lamp holder	T8 LG13-01A
J103	Fluorescent lamp	T5 8W
J104	UV lamp	T6 20W

J105	UV lamp ballast	TL8-20W
J106	Blower	FH320A
J107	Main control panel	FH(X) series fume hood main control panel
J108	Front window glass	900*700*5
J109	Active carbon filter	835*495*30

**FH1200(X) Fume Hood Replacement Part List**

<b>NO.</b>	<b>Part Name</b>	<b>Specification</b>
JJ01	Fuse tube	10A
JJ02	UV lamp holder	T8 LG13-01A
JJ03	Fluorescent lamp	T5 12W
JJ04	UV lamp	T6 20W
JJ05	UV lamp ballast	TL8-20W
JJ06	Blower	FH320A
JJ07	Main control panel	FH(X) series fume hood main control panel
JJ08	Front window glass	1100*700*5
JJ09	Active carbon filter	1030*495*30

**FH1500(X) Fume Hood Replacement Part List**

<b>NO.</b>	<b>Part Name</b>	<b>Specification</b>
JD01	Fuse tube	10A
JD02	UV lamp holder	T8 LG13-01A
JD03	Fluorescent lamp	T5 16W
JD04	UV lamp	T6 30W
JD05	UV lamp ballast	TL8-30W
JD06	Blower	FH320A
JD07	Main control panel	FH(X) series fume hood main control panel

JD08	Front window glass	1400*700*5
JD09	Active carbon filter	1335*495*30

**FH1800(X) Fume Hood Replacement Part List**

<b>NO.</b>	<b>Part Name</b>	<b>Specification</b>
JS01	Fuse tube	10A
JS02	UV lamp holder	T8 LG13-01A
JS03	Fluorescent lamp	T5 16W
JS04	UV lamp	T6 30W
JS05	UV lamp ballast	TL8-30W
JS06	Blower	FH355A
JS07	Main control panel	FH(X) series fume hood main control panel
JS08	Front window glass	1700*700*5
JS09	Active carbon filter	1635*495*30



## 2.6. Wiring Diagram

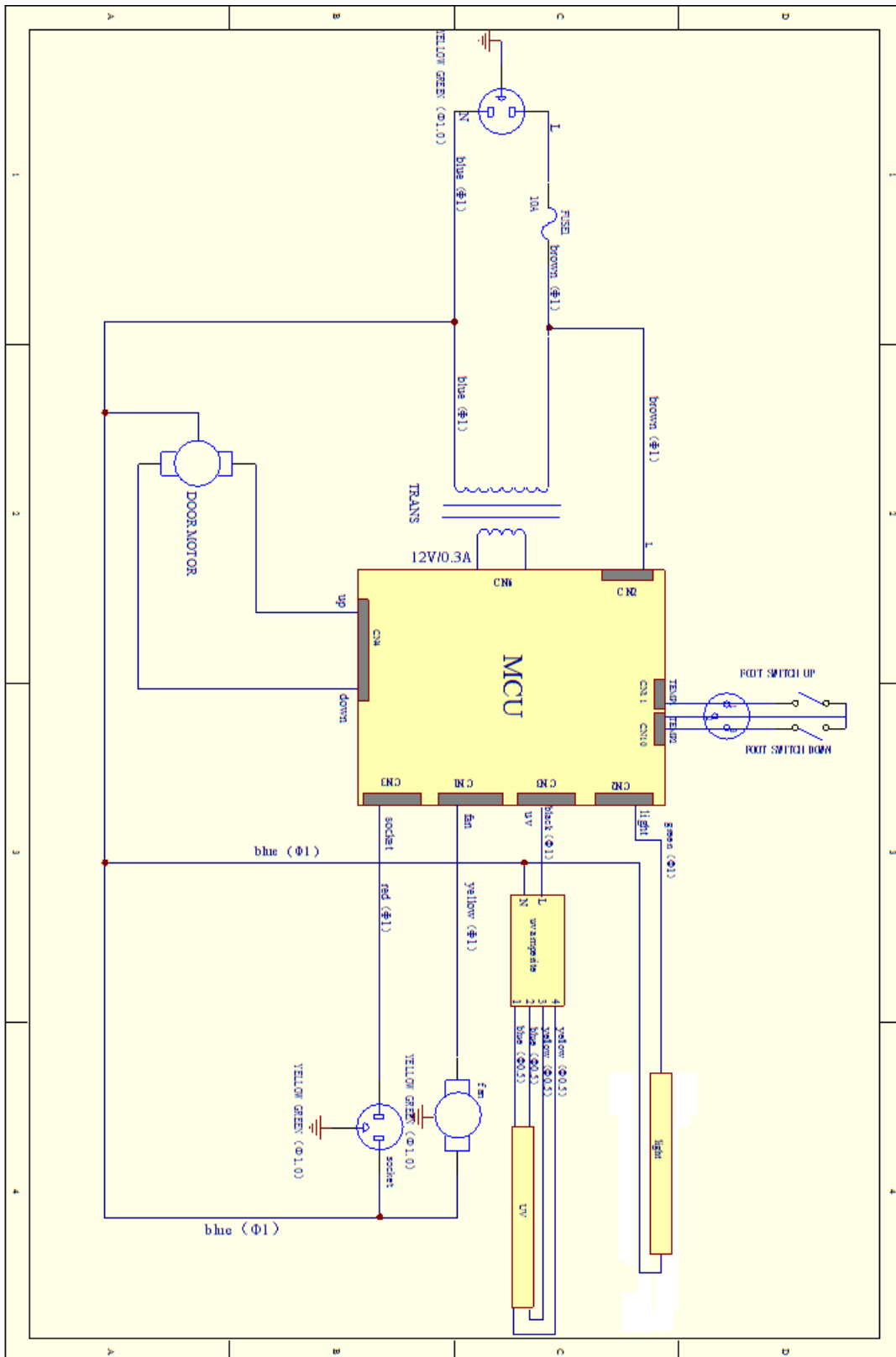

Picture 16

## 3. Trouble Shooting and Labels

### 3.1. Common Failures and Solutions

#### 3.1.1. Trouble shooting

Please confirm that the power is well connected, the power cord, the circuit and the fuses are in good condition (without any damage) before trouble shooting the following problems

In order to ensure the maintenance and use of security, you need check whether the equipment has a reliable grounding measures according to the manual. To check whether the electrical wiring of the equipment is off, broken and short circuit. It should be excluded if similar situation appears

Failures	Checking Part	Suggestion
Fluorescent lamp fail to work	Fluorescent lamp tube	Replace the fluorescent lamp tube
	Circuit	Check the circuit
	Control panel	Replace the control panel
UV lamp fail to work	Fluorescent lamp and blower	Make sure the fluorescent lamp and the blower are turned off
	Lamp holder	Connect the tube and lamp holder tightly
	UV lamp tube	Replace the UV lamp tube
	Ballast	Replace the ballast
Button fail to work	Control panel	Make sure the power is well connected and the fuse is in good condition
		Check if the button is broken
		Make sure the connecting wire is well
		Replace the control panel
Blower fail to work	Front window	Check if the front window is open
	Blower	Replace the blower if it is defective
	Circuit	Check the circuit
	Control panel	Replace the control panel
No electricity in socket	Socket	Check if the socket is broken
	Circuit	Check the circuit
	Control panel	Replace the control panel
	Transmission part	Check the transmission connection and lead
	Motor of front	Check the front window motor

Front window fail to work	Circuit	Check the circuit
	Control panel	Replace the control panel
	Power supply	Check whether the power supply is well
No electricity in equipment	Power cord	Check whether the power cord is in good
	Fuse	Check if the fuse is damaged
	Potential transformer	Check whether the transformer works
	Control panel	Replace the control panel
	Signal transmission	Check whether the signal transmission line
Display fail to work	Display screen	Check whether the screen is in good condition
	Control panel	Replace the control panel
	Circuit	Check circuit
Foot switch doesn't work	Control panel	Change it



**NOTE:** a) The above trouble shooting methods should be done by qualified electricians under safe conditions (cut off power supply). Other components should not be removed. Risk caused by failing to follow those instructions would be responsible by user.

b) Please contact our technical department if a failure could not be traced or solved. Do NOT repair the equipment without a qualified electrician.

c) The trouble shooting and repair of this equipment only could be undertaken by trained and recognized technicians.

d) Please contact our technical department or agent to order required component or part. The model number and the serial number of purchased Fume Hood need to be indicated.

### 3.1.2. Simple accessories replacement

a) Replace the fuse

For replacing the live wire fuse, turn off the power and disconnect the plug. Use a Slotted screwdriver to lever up the fuse holder to open it. Replace the fuse inside the fuse holder and then, press the fuse holder back.

The parameter of the fuse tubes in the round fuse holders are required to conform to labels, it is F10A  $\phi 5 \times 20$  mm.



Picture 17

b) Replace fluorescent light

For replacing the lamp tube, press UP button to rise up the front window to the highest position, then turn off the power and disconnect the plug. Remove the power cord of the lamp tube refer to picture 18. Then remove the lamp tube by pulling the small slice on the tube base as shown in the Picture 18. Install a new lamp tube by pushing it in and connecting with the power cord.

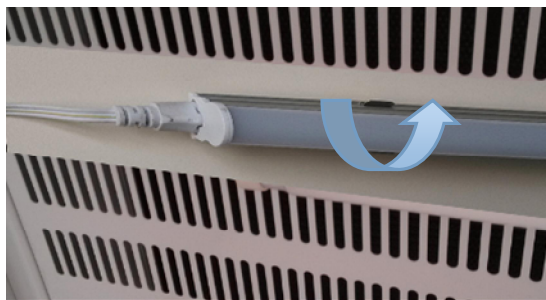

Picture 18

c) Replace the UV lamp

The UV lamp tube should change regularly, for example every 600 hours. For replacing the lamp tube, press the UP button to rise up the window to the highest position, then turn off the power and disconnect the plug. Rotate the tube for 90° to remove it and then install a new UV lamp tube by rotating in reverse direction.



Picture 19

---

## 3.2. Label Description

### 3.2.1. Fuse label

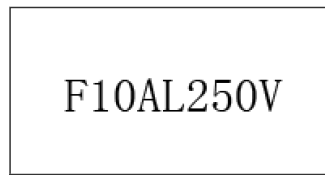

Picture 20

a. 10A power fuse label, located under the female power connector

### 3.2.2. Ground label



Picture 21

## 4. Warranty

- 4.1. Warranty is 12 months from EX-factory date (excluding consumable accessories, UV and Fluorescent lamp, fuse)
- 4.2. We would not be liable for any repair of damage caused by improper operation
- 4.3. If the warranty has been expired, we would still responsible for repair with relative charges
- 4.4. Life time of fume hood is 8 years from production date on the label
- 4.5. We would provide equipment drawings and necessary technical data for maintenance companies or personnel trained by our engineers



**Warranty Declaration: One-year Warranty, Life-long Maintenance**