FH(P)-Series Fume Hood

User Manual

Content

Preface.....	3
Application Range.....	4
Products Features.....	5
Performance Index.....	6
Function and structure.....	7
Notes.....	14
Installation and Using Guide.....	16
Maintenance.....	18
Repairing	20
Guarantee.....	21
Spare Part List.....	22
Wiring Diagram.....	23
Air Flow Diagram.....	24

Preface

Welcome to choose FH(P)Series Fume Hood. And we sincerely hope that our product can bring you best help.

In order to make you understand more clearly about our Fume Hood, please read this manual carefully before you start to use it. It is very important for you to use our instrument correctly and safely.

And please put the manual in appropriate position in order to use it at random.

Application Range

It is the new technical instrument in air condition workshop and clean workshop. And it is widely applicable in electron, chemicals, mechanism, medicine, university and lab. Fume hood can be used in operation of potential risk or unknown infected factors, and the experiment of flammability, explosive volatilization and narcotics. It can protect operator and samples.

Working environment:

1. Only used in door;
2. Environment temperature: $15^{\circ}\text{C}\sim 35^{\circ}\text{C}$;
3. Relative humidity: $\leq 75\%$;
4. Pressure Range: $70\text{kPa}\sim 106\text{kPa}$;
5. Power supply: AC 220V, 50/60Hz。

Product Features

Features of FH(P) Series Fume Hood

Shell: White PP, thickness 8mm, bending designed to avoid spilling over.

Working zone: The working zone adopting high grade melamine board, it has better acid and alkali resistance function. The table board is made up of chemical-resistant laminate, it could removable for cleaning.

Window: More than 5mm thickness of toughened glass

Control panel: It adopt touched-model switch, this type could make more convenient operation and pretty appearance.

Electrical control system: it has the function of preventing over-load and getting an electric shock. It has stable performance to extend life time.

Sockets: adopted specialized safety product of laboratory, it has the performance of dirt proof, water proof and acid-alkali proof. The material is PC Flame-retardant fire.

Performance Index

Velocity:

Inflow Velocity: 0.3~0.8m/s

Vibration:

The net displacement is no more than 5 μ m (rms) when the frequency is from 10Hz to 10kHz

Noise:

The noise is less than 68dB(A) when environment noise is less than 50dB and it is 300mm far away from glass door ,above 380mm from working board.

Resisting pressure: 1390V can not breakdown in 5s;

Grounding resistance: $\leq 0.1\Omega$;

Power supply: AC 220V, 50/60Hz; AC110V 60Hz.

Select	Model	External Size (L*W*H) mm	Working Zone Size (L*W*H) mm	Power (W)	LED Lamp (W)
<input type="checkbox"/>	FH1000 (P)	1047*800*2450	787*560*700	330	12 one
<input type="checkbox"/>	FH1200 (P)	1247*800*2450	987*560*700	360	30 one
<input type="checkbox"/>	FH1500 (P)	1547*800*2450	1287*560*700	360	30 two
<input type="checkbox"/>	FH1800 (P)	1847*800*2450	1587*560*700	360	36 two

Function and Structure

1. Air Filter System (refer to the airflow mode chart)

Air system is the main part to ensure the performance of the fume hood. It is made up of blower and air duct. As the negative pressure, the room air is absorbed into the work area, then exhaust from the top, finally through the special duct to the outside room.

Structure and Components

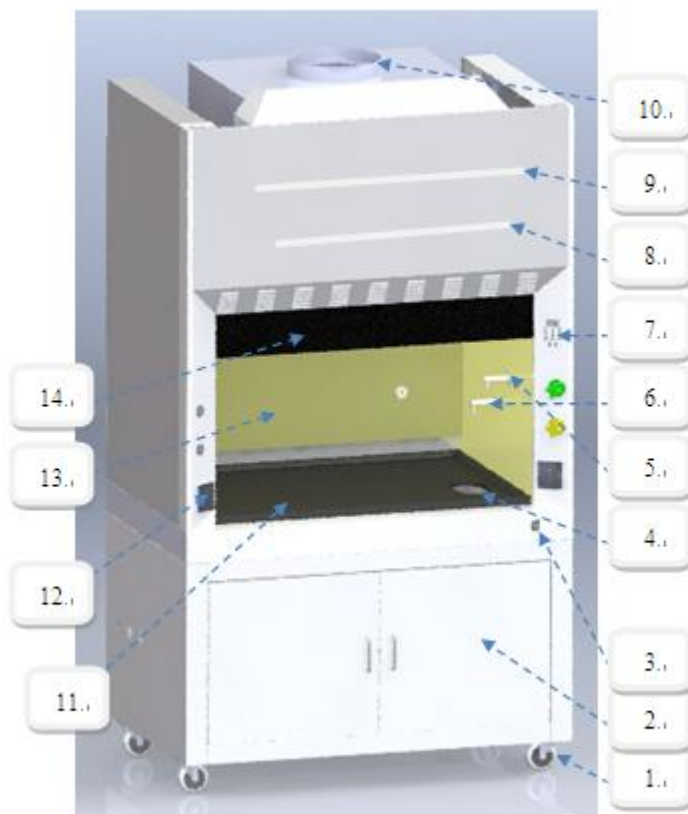

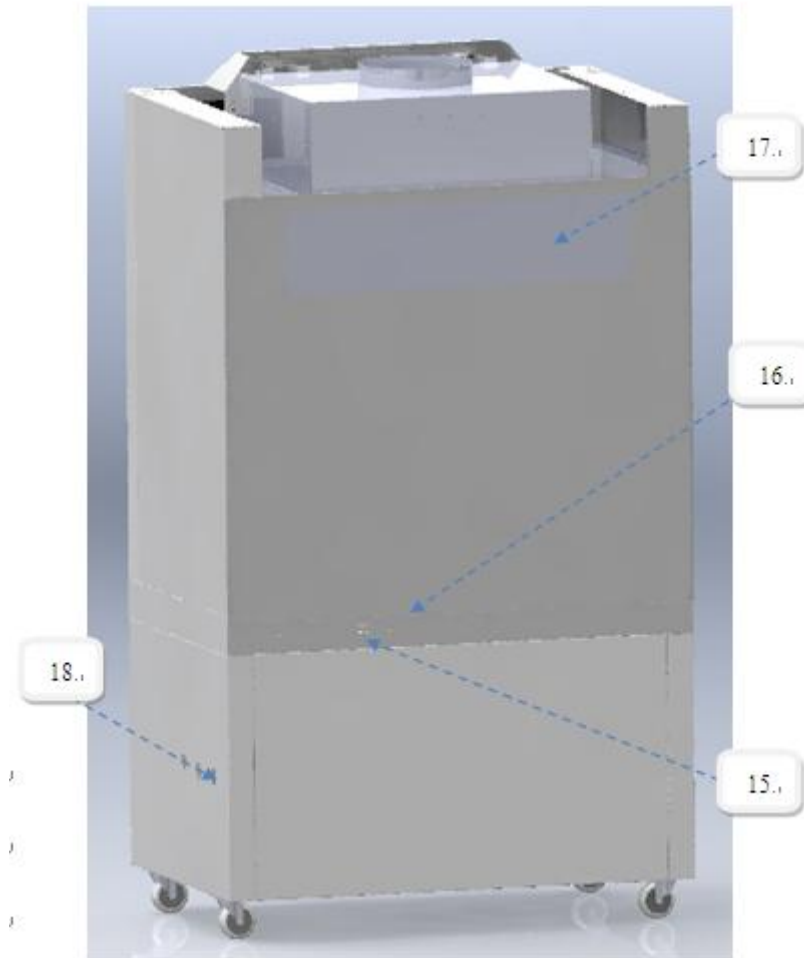

1. castor 2. Base cabinet door 3. rocker Switch 4. water slide
5. fuller faucet. 6. Gas bibcock 7. control panel
9. LED lamp 10. fan and the wind barrels
11. deck plate 12. Socket 13. Compact panel
14. glass door 15. back cover plate 16. fuse holder
17. Power switch 18. pipe hole

★LED Lamp

The LED lamp could ensure the working area have enough light. It made up of LED tube.

★Control Panel

Fume hood controller takes microcontroller as the core and uses modular design. It's main features are full function, simple, clear interface, and easy operation.

- Large-screen LED real-time display various states.
- The current and preset angle of air valve display simultaneously.
- The preset angle of air valve can be adjusted at any time. Power off memory function store the running parameters automatically.
- Automatic delay off function. Automatically shut down after the air valve is closed.
- Limit alarm function to ensure maximum safety of users.

Specifications :

Rated voltage : AC220V (~10% ~+ 7%)

Operating temperature : 0 °C --35 °C

Storage temperature : -10 °C --50 °C



Humidity : 5% - 90% RH non-condensing

Air valve actuator running time : 28 seconds (0 ° --90 °)

Relay contact output capacity : 5A / AC 250V (resistive load)

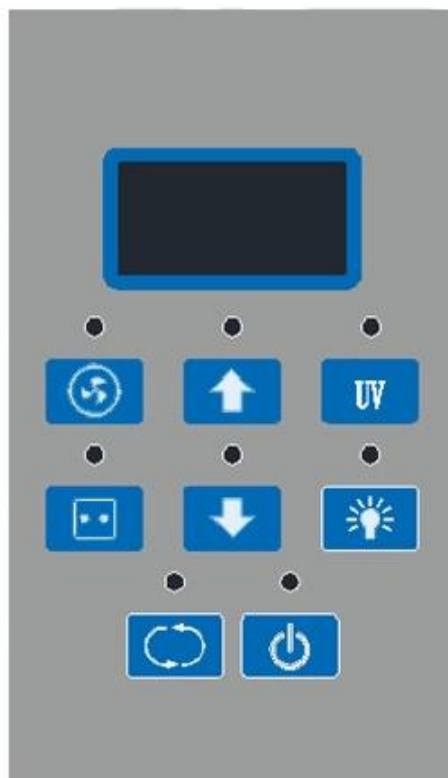
Instructions :



-  Power button, the main switch of the Fume Hood
-  LED lamp, press to turn on the light
-  Blower (Fan), press to turn on the blower







Socket power, press to activate the sockets in the working zone



Adjust fan speed, press to adjust the speed of the blower (fan) from F1 to F9

Operation Process

- a) Connect to a suitable power supply,
- b) Power on the Fume Hood by pressing the power switch under the working zone, the LED screen would be lighted as “”
- c) Press the POWER button  on the control panel to enable all functions (LED lamp, blower, socket). The LED screen would display the accumulated operating time of the blower .
- d) Raise the front window to a proper height.
- e) Press the FAN button  to turn on the blower. The LED screen would display the speed level of the fan memorized from the last time of operation. The indicator light above the FAN button would be turned on to show the working status of the blower. Make sure the blower runs at least FIVE minutes before starting any experiment.
- f) Press the LAMP button  to turn on the LED light. The indicator light above the button would be turned on to show the working status of the LED light. Please refer to the actual condition of illumination in the laboratory room to decide whether the LED light is needed.
- g) After finishing the experiment, turn off the blower and the LED light and close the front window

-
- h) Press the POWER button  to power off the Fume Hood after all functions have been turned off. Press the power switch to disconnect power before plugging out.
- i) If power failure happened during the operation causing by interruption of electricity supply or dropping off of plug or other abnormal situations, the equipment could memorized the current operating status automatically and resume those functions when power on again.

Fault Exclusion:

Fault phenomenon	Check contents	Treatment
No display after power	Power lines, controller fuse	Restore power, replace the controller fuse
Air valve angle display does not match	Air valve factor is whether appropriate	Adjust the air valve factor
Lighting does not light	Ballast, lamp	Replace the ballast, lamp
Fan does not work	Fan contactor, fan	Replace the fan contactor, fan

★ Socket

A socket is set on the right front side of the table-board, it can supply power to the devices in the [operating space](#).



The power of the device using in the working area should less than 500W.

★ Fuse Tube

Fuse tubes are installed at the back of the product, as shown in the structure figure. Fuse tubes are set in the corresponding fuse tube seat and power socket, Fuse tube specifications complies with the label right under the tube, when change the fuse tube , please refer to the label.

Notes

1. Fume Hood is one of the important lab safety devices. In order to correct usage to ensure safety, please read this instructions and notes carefully. If necessary, please join lab safety and operation skills training;
2. Read this manual before you use the fume hood.
3. Please retain this instruction to vide.
- 4.All the damage caused by the misuse or change the constructions unauthorized,We will not take any responsibility.
- 5.The fume hood should avoid laying nearby the personnel frequency gate/window or the corridor.
6. The power should have good earthing.
- 7.Before changing the LED lamp, the power should be put off.
8. After packing, the package should be store at the following circumstances: the temperature should be less than 40°C; The relative humidity should below 85%; no aggressive gas exists and it has good ventilation.
9. The front perspective window of the fume hood is made of explosion-proof toughened glass, to keep clean, it should the wiped by wet soft close and kept away from HF and other acid;
10. The assembly should be cleaned regularly according to the usage, such as flow guiding plate etc;
11. The flow tunnel and flower etc. should be clean, maintain by specially-assigned person
12. Not any device should be placed within 150mm away from the front

window, and it's better to adjust the front window to the low height, as the fume hood needs enough space to ensure the airflow.

13. In the course of usage, please try not to put the soft things (such as the paper towel) on the table top, to avoid it been absorbed in the wind hole or blower;

14. For our company product modeling and color pictures, please see the real product for detailed information. Models are subject to change without prior notice.

Declaration: Any danger caused by abuse, We will not take any responsibility!

Installation and Using Guide

I. Installation

1. Install position

The fume hood is better not be positioned at the place where people pass by frequently, where may block the window or light, where may obstruct the door opening.

2. Preparation before installation

- 1) Check the surface of package and damage situation ;
- 2) If the equipment was delivered in cold weather, put in a warm place for 24 hours before use.
- 3) Before breaking the package, move the entire equipment to the place where as close as possible.

3. Installation

- 1) Clear the package material and **packing fragments** inside the case.



Any packing fragments may lead to the damage of filter and air blower.

- 3) Confirm the complement of accessories according to the list.
- 4) Check the condition of fume hood, find if there is any damage on the surface and the component inside the working zone is tight ;



Do not put hand in the exhaust fan in any case

4. Checking and Debugging

Run fume food and test its function for trail, to make sure all functions

are normal, there should be no noise inside the cabinet, exhaust pipe unimpeded, air blower works like normal.

5. Training

After the installation, train the operators basic use steps and cautions.



Untrained or unqualified persons should not use this equipment.

II Usage

1. Prepare before work

Put the plug in socket, put the other end to net socket, the required power supply is 220V 50/60 Hz.

2. Function switch/buttons

See P8 introduction

3. Operation

When power is ready, turn on the switch, let cabinet electrified. Press the “Power” key then after the blower runs 5 minutes the cabinet will be ready to use. When running, the LED screen will show pressure difference between two sides of filter, if the value exceeds 200Pa, the alarm will hoot to remind that filter needs to be changed. If experiment tools need to be put inside the cabinet, do that before using, do not open window frequently during use.

Maintenance

I. Maintaining period

Each year or every 1000 working hours and before each restart, proper maintaining should be applied.



1. Cut the power off before daily maintain;
2. The working hours counting directly effect the maintaining decision, we recommend make a particular schedule and record as reference
3. Exhaust pipe and outside pipe must be maintained often.

II. Recommended maintaining and repairing method

a) Surface Clean

To keep the cabinet clean, clean the cabinet periodically (suggest at least every week), wipe the surface by soft rag dipped soap water. Do not spread any chemical liquid on the screen, in order to avoid color fade or dim letters. Window and cabinet surface should be cleaned by special chemicals.

b) Fuse plug replacement

There is a around tube fuse plug base at the right plate of the cabinet, the models are marked in labels that are F5A $\phi 5 \times 20$ mm for power socket, and F10A $\phi 5 \times 20$ mm for zero line, When the plug need to be changed, pluck off power cable plug, press and twist fuse base anticlockwise by straight screwdriver, change the fuse, twist fuse base clockwise. To change the fuse in socket, pry out the fuse base by straight screwdriver to change the fuse, and then push it back.

III. Light change

When the light need to be changed, power off the cabinet, open the front plate, remove the screws at both sides of the cabinet, open the front cover plate, twist off the light tube, replace by a new one, fix the font plate.

IV. Filter change

If the product is equipped with activated carbon filters or other types of filters, the filters should be replaced in time based on the fume hood's using time and environment. Remove the holding bolt of the back cover plate from the back of the cabinet with a screwdriver, and then remove the bolt on the filter fixed layering with spanner. Take down the old filter, and put a new filter of the same model into the right position of the cabinet according the original installation, then tighten bolts and layering, and install the back cover plate.

Repairing

1. Before Maintenance

1. To check whether the equipment implements grounding measures to ensure safe use following instructions. Inspect electrical wiring devices to see if there is a fault, short circuit, and if these occur, should be canceled at once;

2. Judgment and maintenance for regular fault

1) The screen is not bright

Check whether the power is on and the conditions for the importation, whether or not the insurance control tube is broken;

2) LED lamp is not bright. Replace LED lamp



The above-mentioned electrical components must be operated by a qualified electrician in the safety conditions (cut off power supply). Other parts are not allowed to be disassembled, or consequences responsible by users themselves;

1. When the equipment breakdown is caused by another fault, and the operators cannot handle it immediately, please notify our company's maintenance department immediately. In order to your safety, do not maintain equipment on your own;

2. Maintenance of the equipment is only recognized by the training of technical personnel;

3. If you need to order parts, please contact our technology services sector, please specify the Fume Hood type and number.

Guarantee

- | The guarantee period is 12 months from shipment date.(not include lamp, fuse tube)
- | Our company assumes no obligation to warranty the equipment failure or damage due to the improper use within the warranty period.
- | Our company responsible for maintenance after warranty period, the maintenance fee charged.
- | Provide the necessary drawings and technical data to the person or institution which is trained and recognized by our company.

Spare part list

250V , 10A Fuse tube	2 (replacement is allowed by user following instructions)
250V , 5A Fuse tube	1 (replacement is allowed by user following instructions)
Power line	1 piece

Wiring Diagram

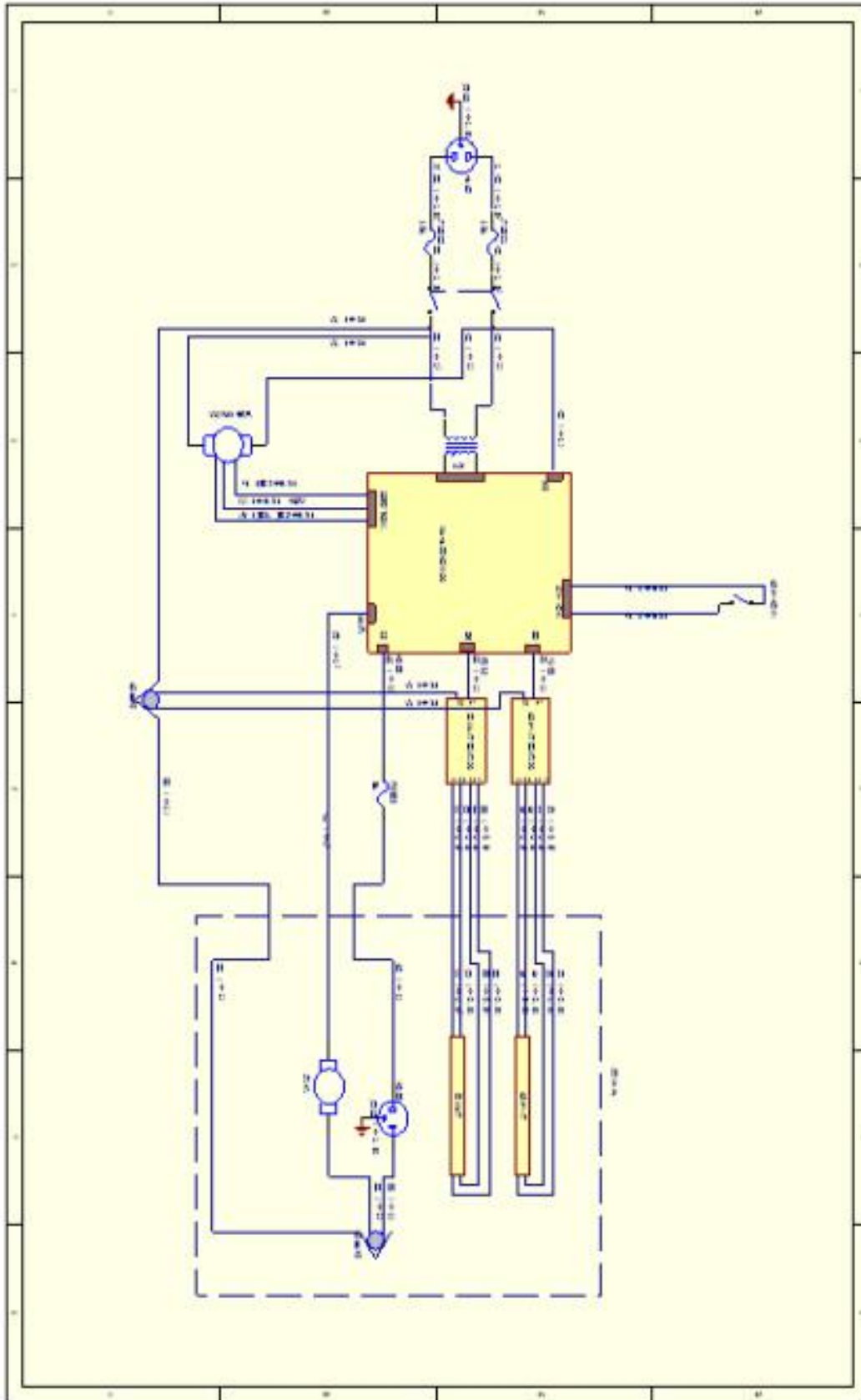

Airflow diagram

