

**Fume Hood**  
**FH700**  
**User Manual**

**Version 2021.05**

---

## **Preface**

Dear respected user:

Welcome to select and purchase our FH700 fume hood, here please accept our sincere thanks!

We sincerely hope that our product can bring the greatest help for your work.

In order to make you more aware of the fume hood, please be sure to read the manual carefully before you start using it. The contents of this manual are very important for your safe and proper use of this machine!

After having been familiar with the manual, please keep this manual in a place which is convenient to use for easy access.

# Content

Preface.....	1
Content.....	2
1. Unpacking, Installation & Debugging .....	4
1.1 Unpacking of Cabinet .....	4
1.2 Accessories Checking .....	6
1.3 Machine Installation Site and Use Environment .....	6
1.4 Installation.....	6
1.5 Post-installation Checking .....	8
2. Instruction for Use .....	9
2.1 Function .....	9
2.1.1 Product Concept.....	9
2.1.2 Working Principle / Airflow Mode Protection Area Diagram.....	9
2.1.3 Objects Protected .....	9
2.1.4 Technical Parameters & Performance Indicators .....	9
2.2 Product Structure .....	10
2.2.1 FH 700 Fume Hood Structure.....	10
2.2.2 Structure Description .....	11
2.3 Points that Should Be Noted in Normal Operation & Normal Operation Process .....	12
2.3.1 Points that Should Be Noted in Normal Operation.....	12
2.3.2 Normal Operation Process .....	13
2.4 Daily Maintenance .....	14
2.4.1 Surface cleaning.....	14
2.4.2 Storage Condition .....	14
2.5 Accessories Replacement List .....	15
2.6 Wiring Diagram .....	16
3. Common Fault Analysis & Analysis .....	17
3.1 Common Fault Analysis .....	17
3.2 Method for Replacing Simple Parts.....	18

---

3.2.1 Replace protective tube (fuse) .....	18
3.2.1 Replace fluorescent lamp .....	19
3.3 Label Description.....	19
4. Warranty .....	20

# 1. Unpacking, Installation & Debugging

Please check whether the packing box is intact, if not, please take photos.

## 1.1 Unpacking of Cabinet

(The user can choose the proper unpacking method according to the actual situation.)

Method 1: Unpack with a wrench M8



Figure 1

Method 2: Unpack with an electric drill M8 sleeve



Figure 2

Rapid unpacking diagram ( Disassemble the screws, as are shown in the below figure, then take the wooden box to the left and right.)

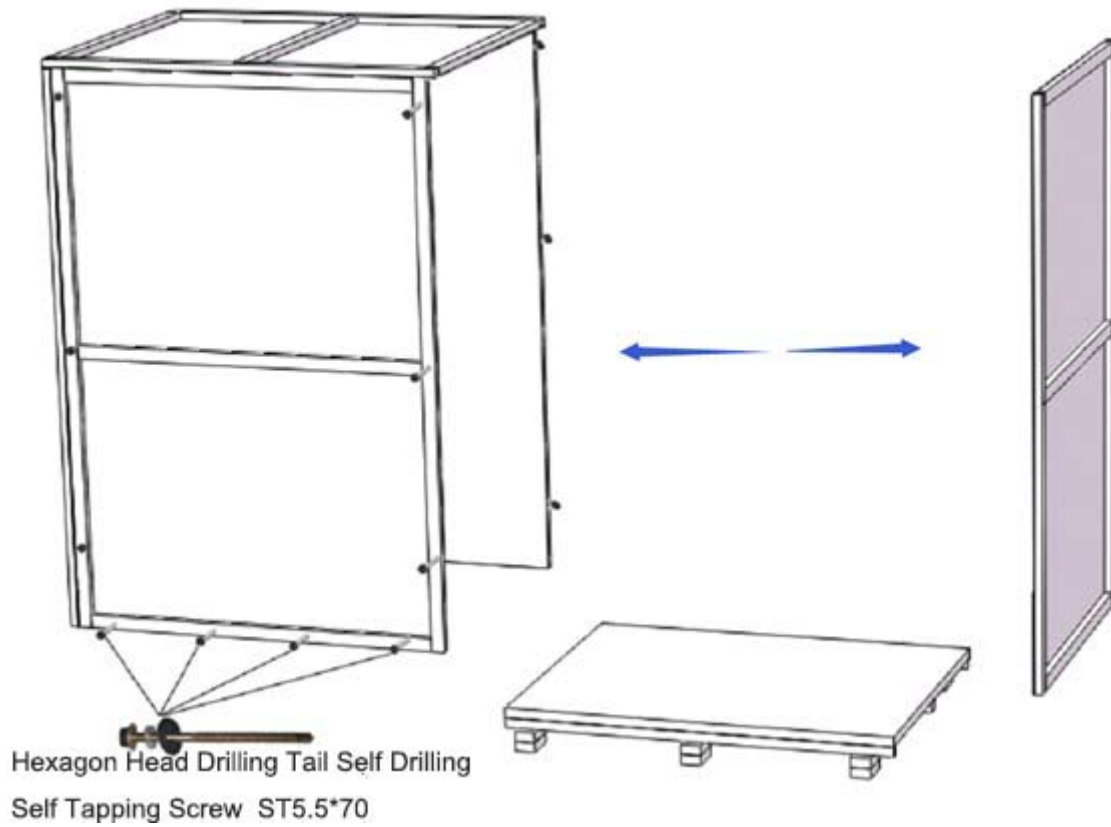

Figure3

box2 Rapid unpacking

Cut the packing belt off with an ordinary scissor, remove the top cover of the paper packing, and move the paper packing frame upward.



Figure 4

---

## 1.2 Accessories Checking

Please refer to the packing list, carefully check whether the accessories and information are complete.

### Hume Hood Packing List

Upper cabinet:

No.	Name	Quantity
1	Cabinet	1 unit
2	User manual	1 copy
3	Certificate	1 sheet
4	Test report	1copy
5	Fuse (5A)	1pc
6	Power Cord	1pc
7	Exhaust pipe	1pc
8	Pipe clamp	2pc
9	Base (base connector) (optional)	1 set

## 1.3 Machine Installation Site and Use Environment

Installation site

Installation site of fume hood should be avoided to face road and sites people frequently go through, avoided to clog windows and places where ventilation and lighting are not good, avoided to block the entrance and exit and place where the open or close of the door is affected , and avoided to place oppositely or in the corner of the wall.

Use environment:

- a、 For indoor use only;
- b、 Environment temperature: 15°C~35°C;
- c、 Relative humidity:  $\leq 75\%$ ;
- d、 Atmospheric pressure range: 70 kPa~106 kPa;
- e、 Power: the same with the rated voltage, rated frequency of the cabinet, as is shown in the 2.1.4 Technical Parameters Performance Indicators Table
- f、 Power supply needs reliable grounding; (judgment method: Use a multimeter to test the voltage of the live line to ground and the voltage of the null line to ground respectively, among which, the voltage of the live line to ground should be the grid power, and the voltage of the null line to ground should be 0, otherwise, the power is not grounded well).

## 1.4 Installation

- a、 Remove all packaging components
- b、 Check whether the outer surface of the cabinet has scratches, deformations or foreign objects;
- c、 Check carefully the accessories and information by referring to the packing list in the user manual;
- d、 Move the entire equipment to a site which is as close as possible to the position where the equipment is placed finally and convenient for installation;
- e、 Put the cabinet on the side platform of the lab.

f、 Check whether the ambient voltage frequency is consistent with the voltage frequency shown on the label, then power on;

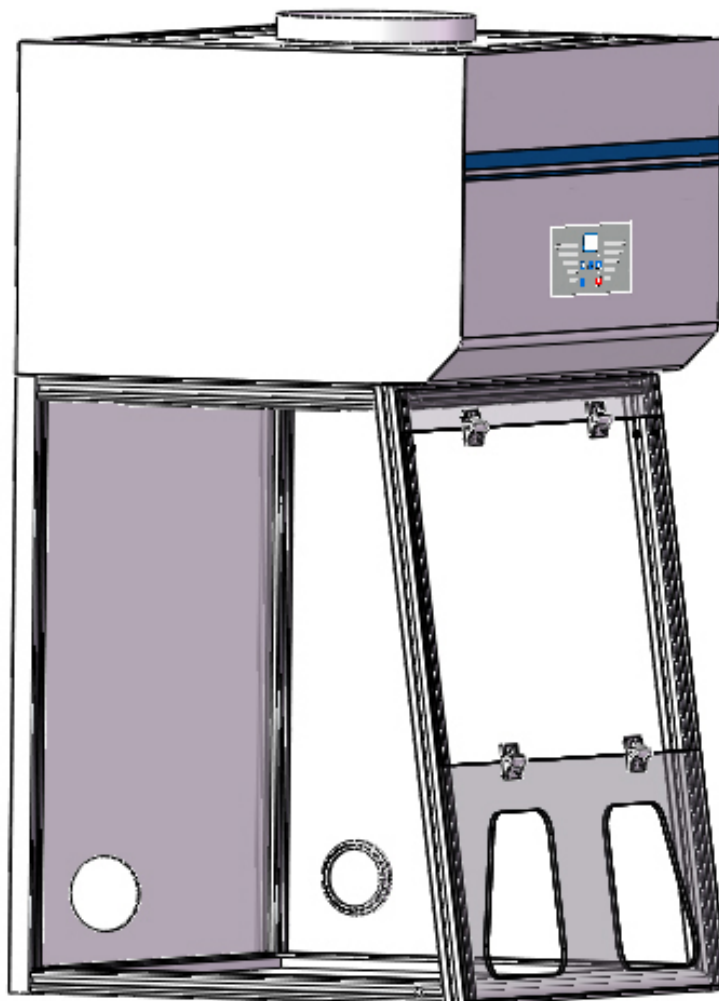

Figure 5

g、 Method for installation of base(optional) is as follows:

(1) Take a base rectangular pipe, and place it as is shown in the figure, then take 10 stainless steel hexagon socket bolts (M10),10 stainless steel spring washers 10, 10 stainless steel flat washers 10, to assemble the base;

(2)Place the fume hood above the base, take 4 stainless steel hexagon screws (M6 \* 35), 4 stainless steel spring washers 6, 4 stainless steel flat washers 6, and pass through the base from the bottom of the base, then connect the base with the fume hood.



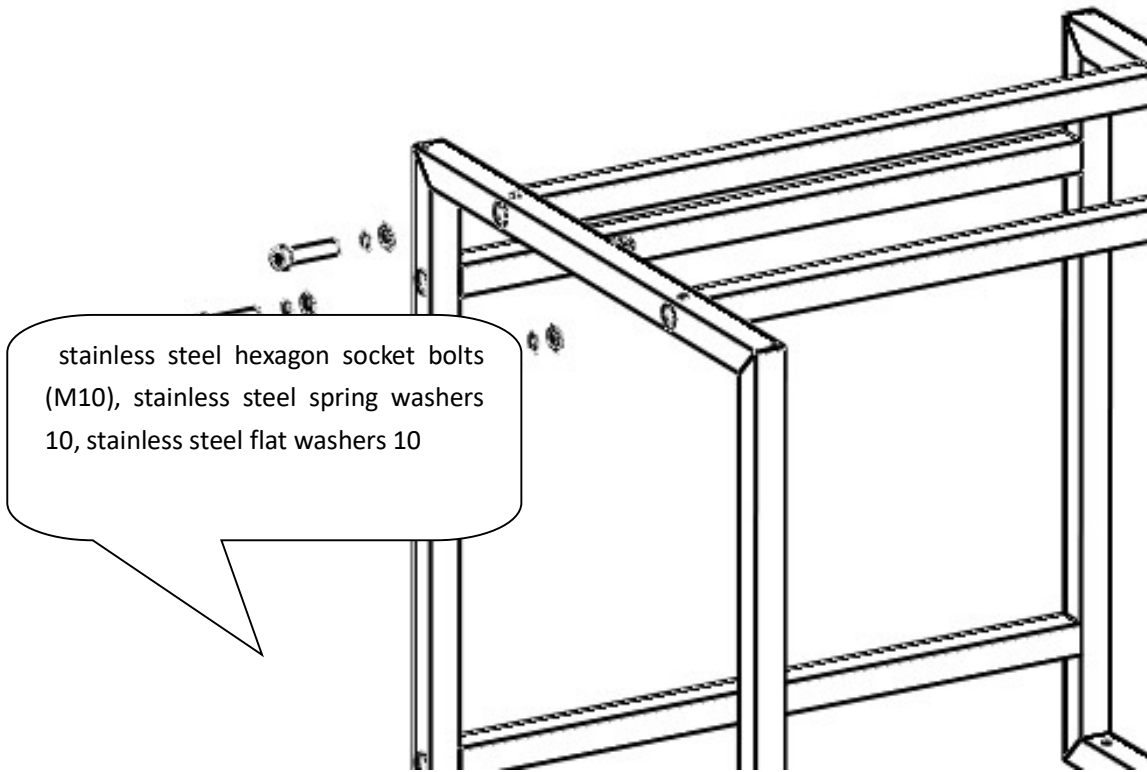

Figure 6

### 1.5 Post-installation Checking

1. Refer to 2.3.2 Normal Operation Process and check the following items, after the fume hood is powered on.

Checking Items	Normal Status
Power status	The equipment could be powered on/off after pressing the power button;
Fan	Runs normally after pressing the Fan button; speed could be adjusted by pressing the adjusting button;
Front acrylic door switch	The status is normal;
Fluorescent lamp	Lamp lights up after pressing button.



**If the equipment has problems, please contact the local dealer for debugging, for the debugging methods, please refer to the after-sales service manual**

## 2. Instruction for Use

### 2.1 Function

#### 2.1.1 Product Concept

In the chemical laboratory, the experimental operation will produce a variety of harmful odor gases, bad smell, moisture and corrosive substances, in order to protect the safety of users and prevent contaminants in the experiment from spreading to the laboratory, the fume hood is used in the vicinity of pollution sources.

Note: This type of fume hood cannot be used in experiments with strong acid and alkali, flammable and explosive substances.

#### 2.1.2 Working Principle / Airflow Mode Protection Area Diagram

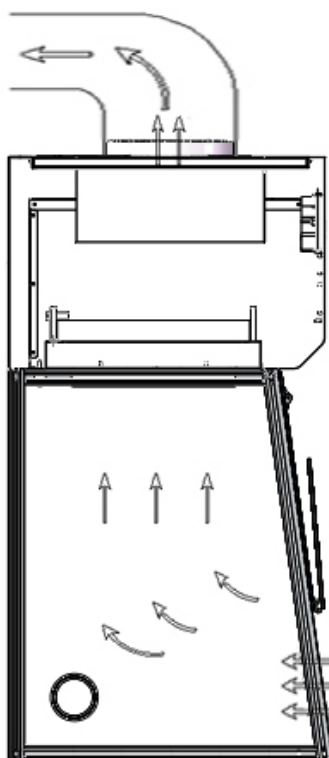

Figure 7

#### 2.1.3 Objects Protected

Safety is the top mission of the fume hood, the use of fume hood in the laboratory is to ensure the safety of users and to prevent the laboratory environment from being polluted.

#### 2.1.4 Technical Parameters & Performance Indicators

Model Technical Parameters	FH700	
Rated voltage AC	220V±10% <input type="checkbox"/>	110V±10% <input type="checkbox"/>
Rated frequency	50 Hz <input type="checkbox"/>	60Hz <input type="checkbox"/>
External dimension	700*620*1150 mm	

Operating area dimension	640*550*700 mm
Rated power	300 W
Inflow velocity	0.3~0.8m/s
Fluorescent lamp power	T5 4W *2
Noise	≤68dB (A)

Note: (1)We reserves the right to change the design, if the product design is changed, we shall no longer inform the user.

1) Vibration amplitude:

The net vibration amplitude between 10Hz and 10kHz frequency is  $\leq 5 \mu\text{m}$  (rms)

2) Withstand voltage: If the voltages rises within 5s to 1390V AC voltage, the fume hood could not break down within 5 seconds;

3)Grounding resistance:  $\leq 0.1\Omega$ ;

## 2.2 Product Structure

### 2.2.1 FH 700 Fume Hood Structure

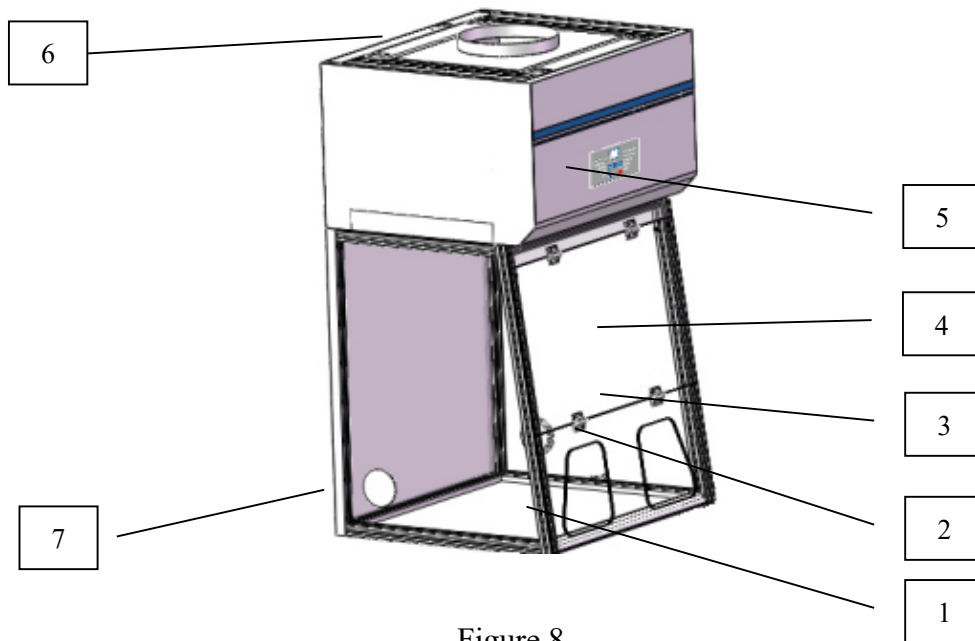

Figure 8

- 1. Deck panel
- 3. Torque hinge
- 5. Control panel
- 7. Rubber plug

- 2. Front window (lower part)
- 4. Front window (middle part)
- 6. Power socket

## 2.2.2 Structure Description

### ★Lighting source

LED lamp is used for lighting, to ensure the average illumination in the operating area meets the standard requirements.

### ★Control panel

The control panel of the equipment has power button, fluorescent lamp button, fan speed-adjustment button, UV lamp button, 5 touching buttons, as well as wind speed gear display unit, indicator for each function.

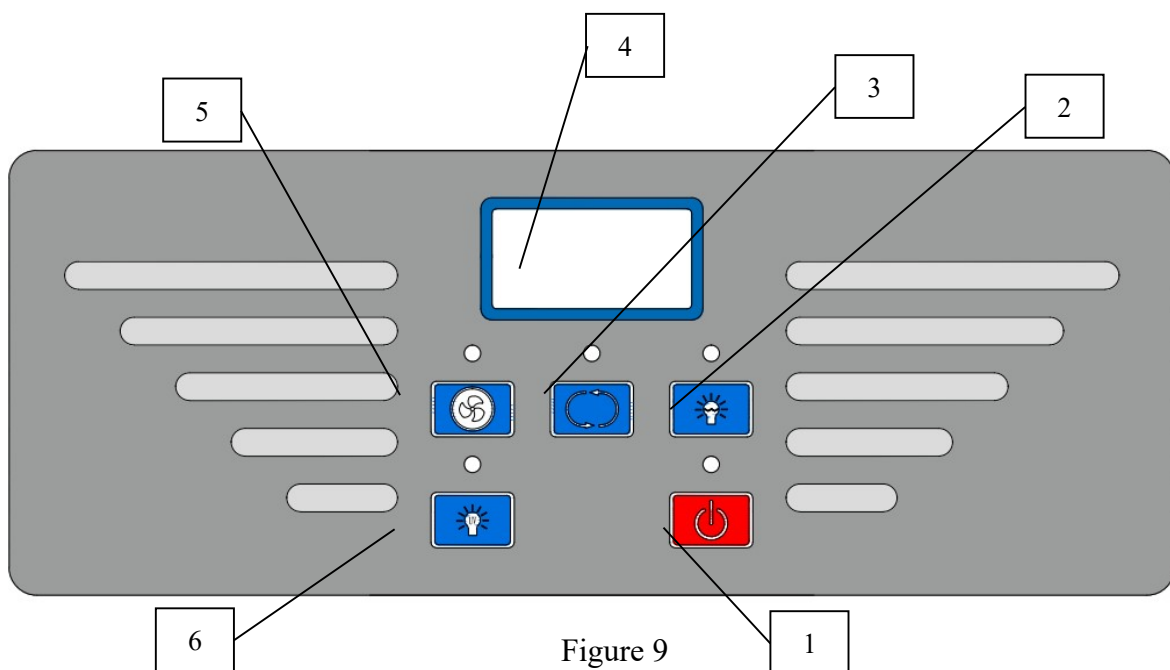



Figure 9

### Lightly press the button

The key to human-computer interaction is that the main operation of the equipment can be done by touching the buttons. By touching buttons, the equipment can achieve the most basic functions;

Power button:  the main switch to control the other function buttons, as is shown in No.1 of Figure 9.

the control button of the working state of the fan, as is shown in No.5 of Figure 9. Each touching can change the working state and the corresponding display state once.

Fan speed-adjustment button, , control button of fan wind speed, as is shown in No.3 of Figure 9. Each touching can change the working state and the corresponding display state in the wind speed gear display unit once. There are 4 gears to adjust, namely, from F1 to F4, when it is in F4, one more touching will be F1.

Each time, when the fan gear is adjusted, the current value will be memorized, that's to say, each time, when the fan is powered on, the gear is the same with that when the fan was powered off last time.

Fluorescent lamp button: , control button of the fluorescent lamp, as is shown in No.2 of

---

Figure 9. Each touching can change the working state of the lamp and the corresponding display state of the indicator once, namely from lightening to darkness, or from darkness to lightening.

UV lamp button: UV, control button of UV lamp (optional), as is shown in No.6 of Figure 9. UV lamp interlocks with fan, fluorescent lamp, that's to say, when the fan or the fluorescent lamp is powered on, the UV lamp will automatically power off.

### ★Fuse

The installation site of fuse is in the rear of the cabinet's top, as is shown in (Figure 8),the power socket of FH 700 fume hood is equipped with live line fuse, the specification of which is consistent with the content of the label pasted on the bottom, and the replacement should refer to the label content.

### ★Structure

- a) External case body adopts 1.0 mm cold-rolled steel with electrostatic coating and rust-proof treatment.
- b) The desk panel adopts solid chemical resistant laminate, which can be disassembled, and the cleaning is convenient.
- c) The left, right, rear windows adopt 5mm thick tempered glass, and the front window adopts acrylic, which can be stopped at any time.
- d) Control panel adopts touch switch, making the appearance of the equipment beautiful, besides it is easy to operate.
- e) Electronic control system is equipped with anti-overload, anti-electric shock and other functions, making the performance stable, and lifespan

## 2.3 Points that Should Be Noted in Normal Operation & Normal Operation

### Process

#### 2.3.1 Points that Should Be Noted in Normal Operation

##### Precautions

Fume hood is the important laboratory safety equipment, please read this manual and precautions, as well as participate in laboratory safety and skills training to ensure normal and safe use.

- 2、 Please read this manual before using the fume hood.
- 3、 Please keep this manual for further reference.
- 4、 Any damage caused by the inappropriate use or product structure change. Our company is out of responsibility.
- 5、 The fume hood should avoid putting on the corridor or near the door or window with a frequent personnel floating.
- 6、 The power socket is grounded well.
- 7、 The equipment should be powered off and unplugged before doing any replacement of parts, such as UV lamp and fluorescent lamp.
- 8、 The packed fume hood should be stored in a warehouse with relative humidity no more than 75% and temperature lower than 40°C. The warehouse should have good ventilation performance without

---

acid, alkali or other corrosive gases.

9. The front window is made of acrylic, and the perspective window is made of explosion - proof tempered glass. In order to keep the perspective window clean and clear, please wipe it by wet soft cloth and keep it away from HF acid, etc.

10. The air deflector and other internal accessories should be cleaned according to the use of the fume hood.

11. The air duct and the blower of the Fume Hood should be cleaned and maintained regularly in a proper way

12. Do not put any equipment in a range within 150mm away from the glass window, large experimental equipment needs to have sufficient space, the flow of air should not be affected.

13. Do NOT place any soft or tiny materials (such as soft tissue) on the work table during the operation to prevent breakdown of the blower causing by sucking those materials

14. The picture and design of the product of our company are subject to the material object, if there are changes in the product model, we shall no longer inform the user.

**NOTE: WE WILL NOT BE LIABLE FOR ANY RISK OR DAMAGE ARISING FROM YOUR FAILURE TO APPROPRIATELY OPERATION THE FUME HOOD!**

### 2.3.2 Normal Operation Process

a. Power on the fume hood by pressing the power switch, the LED screen would be lighted and “---” would be shown.

b. Press the POWER button on the control panel, the LED screen would display the accumulated operating time of the fan( that is the working time of the filter, the displayed value multiply by 10 is

the actual time, unit: hour), press the  button, the screen will display the gear of the fan worked for last time, the fan indicator

above the fan button will be lightened, and the operation can be done after working for 5 minutes.

c. Press the , the lighting indicator above the button will be lightened, one more pressing will turn off the lamp ( according to the laboratory environment, select to power on or off the lamp)

d. After using, turn off the fan and the fluorescent lamp.

e. Power off the , the equipment will be turned off for protection.

f. Press the UV button to turn on the UV lamp (optional), the indicator above the button would be turned on. After about 30 minutes, press the UV button again to turn off the UV lamp. The UV lamp interlocks with the fan, fluorescent lamp, only when the fan and the fluorescent lamp are turned off, can the UV lamp be turned off (according to the using condition of the equipment, select to turn on or off the UV lamp).

 (1) **When the UV lamp (optional) is in working status, people should leave the room in order to protect skin and eyes.**

(2) **UV lamp (optional) should be replaced regularly according to the frequency of use. The service life of UV lamp is about 600 hours.**

g. After turning off the UV lamp (optional), press the , to power off the equipment.

---

h、 If power failure happened during the operation caused by interruption of electricity supply or dropping off of plug or other abnormal situations, the equipment could memorized the current operating status automatically and resume those functions when power on again.

## **2.4 Daily Maintenance**

Cycle for full maintenance

Maintenance should be done every year or every 1000 work hours, and every restart.



- 1. Please firstly turn off the power before conducting the daily maintenance;**
- 2. Since the statistics of the operating time will directly affect the judgment of the maintenance needs, we recommend that you can prepare a detailed record of the operating time for reference and inquiry when you are using the equipment;**
- 3. For filter, fan and external pipeline (optional), regular inspection and maintenance should be done**

Maintenance method:

- 1) Weekly or monthly maintenance
  - a、 surface cleaning: ( refer to 2.4.1 description)
  - b、 Check whether the various functions of the equipment are normal;
  - c、 Record the maintenance.
- 2) Yearly maintenance
  - a、 Check the tightness of the front window hinge
  - b、 Check the fluorescent lamp tube
  - c、 Apply for inspection for the overall performance of the fume hood annually, to ensure the safety of the fume hood performance, and the inspection fee shall be borne by the user.
  - d、 Record the maintenance.

### **2.4.1 Surface cleaning**

In order to keep the cabinet clean, please regularly (at least once a week) clean it. The wipe should be done with a dry soft cloth with soapy water being wringed. Do not spray any chemical reagents on the operator panel or other labels to prevent discoloration of the label film or the writing is unclear . Clean the outer surface of the cabinet and the anti-static curtain with a flexible detergent or glass-specific cleaning agent.

### **2.4.2 Storage Condition**

Fume hood should be stored in a warehouse with the relative humidity of not more than 75%, the temperature below 40 °C, good ventilation, no acid, alkali and other corrosive gases, the storage period should not exceed one year, for the fume hood more than one year out of the box check should be done, the ones that pass the out of the box check can enter the market.

---

## 2.5 Accessories Replacement List

FH700 Accessories Replacement List

No.	Name	Specification
01	Fuse	5A
02	Fluorescent lamp tube	T5 4W
03	Fan	SC225A1-AGT-13-001
04	Main control panel	Main control panel of FH700 fume hood
05	Activated carbon filter	650*365*30
06	UV lamp ( optional)	T8 15W
07	HEPA filter (optional)	650*365*50



## 2.6 Wiring Diagram

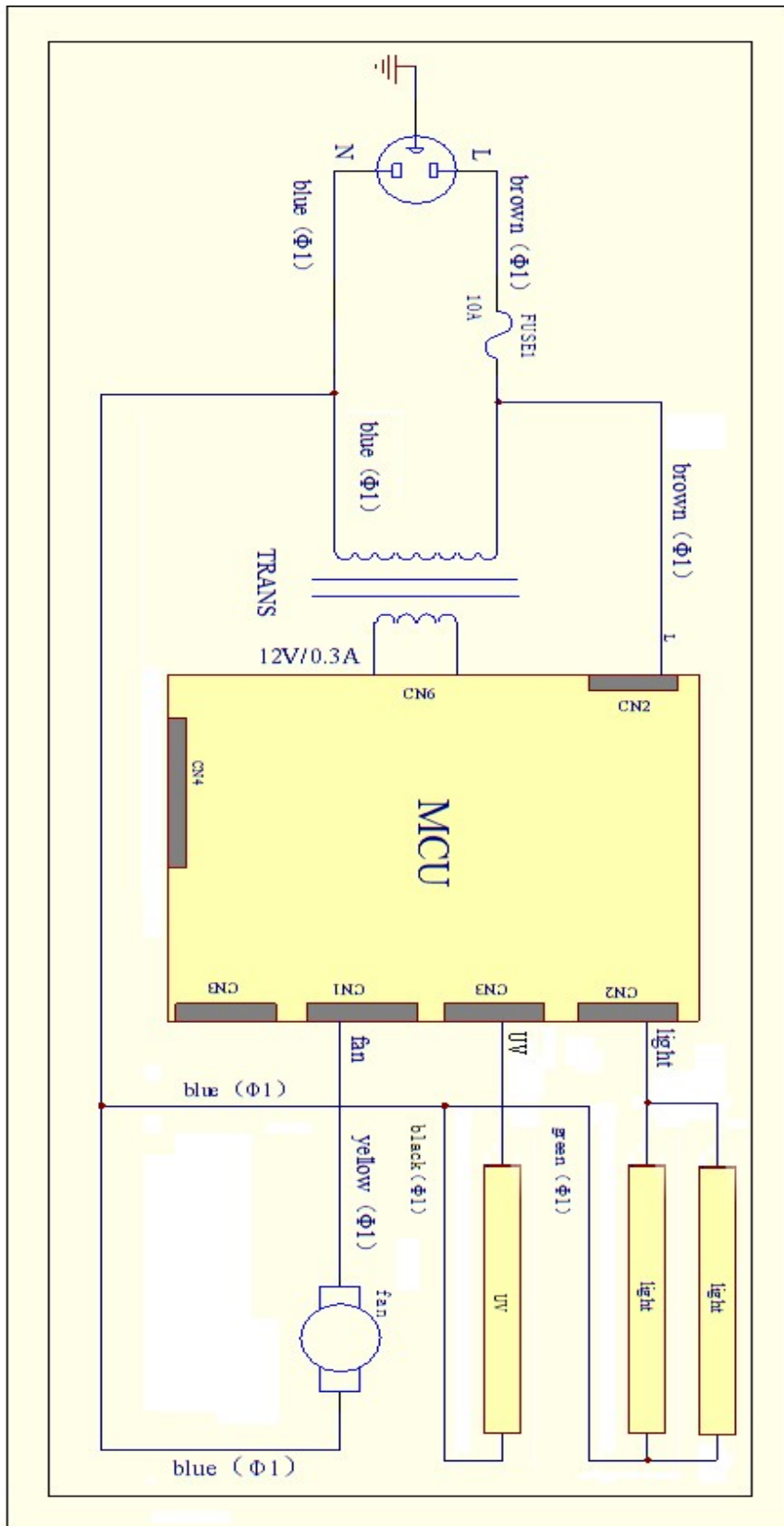

Figure 10

### 3. Common Fault Analysis & Analysis

#### 3.1 Common Fault Analysis

Before diagnosing the faults, please make sure whether the power supply is connected well, whether the power cord is obviously damaged, and the protective tube is good.

1、 Check whether the equipment is grounded reliably in accordance with the requirements of the instructions, to ensure the security of maintenance and use. Check whether the electrical wiring of the equipment is off, broken and short-circuited, if so, please exclude them one by one;

2、 Judgment and Solution of Common Failures

Faults	Checking Part	Solutions
Fluorescent lamp does not work	Lamp holder	Check whether the lamp tube and the holder is connected firmly
	Lamp tube	Replace the fluorescent lamp tube
	Circuit	Check the circuit
	Control panel	Replace the control panel
UV lamp (optional) does not work		Refer to the solutions to solve the fluorescent lamp does not work
Button does not work	Control panel	Make sure the power is well connected and the fuse is in good condition
		Check if the button is broken
		Make sure the connecting wire is well connected
		Replace the control panel
Fan does not work	Fan	Replace the fan if it is defective
	Circuit	Check the circuit
	Control panel	Replace the control panel
No electricity in equipment	Power supply	Check whether the power supply is well connected
	Power cord	Check whether the power cord is in good condition
	Fuse	Check if the fuse is damaged
	Transformer	Check whether the transformer works normally
	Control panel	Replace the control panel

Display does not work	Connection cable	Check if the connection cable is in good contact
	Display screen	Check whether the screen is in good condition
	Control pane;	Replace the control panel

## 3.2 Method for Replacing Simple Parts

### 3.2.1 Replace protective tube (fuse)

The protective tube at the top of the fume hood's cabinet is determined by the label, namely, F5A  $\phi 5 \times 20$  mm. When the live line protective tube needs to be replaced, unscrew the protective tube holder with a flat-blade screwdriver and replace with a new fuse, , after which, press it back.

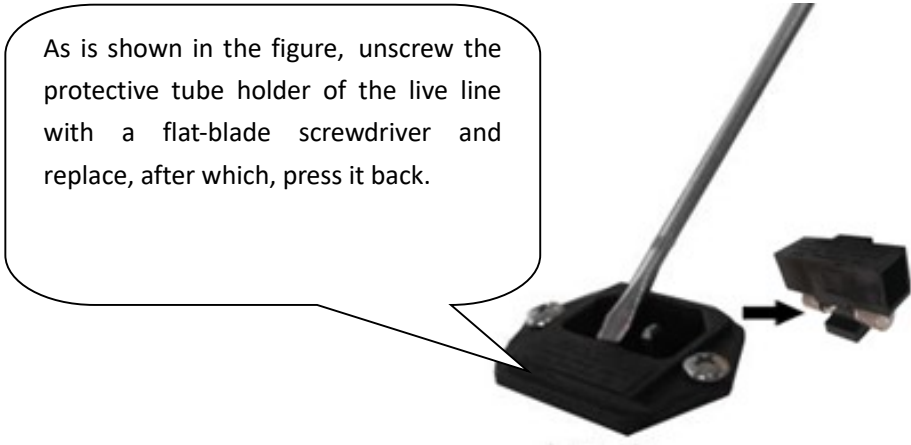

Figure 11

### 3.2.1 Replace fluorescent lamp

Remove the lamp cable, slightly bend the LED lamp holder, remove the old LED lamp. Take a new LED lamp, install it in the original position and connect the lamp cable. Turn on the power button and the lighting button, to check whether the LED lamp is without problem.



Figure 12



**(1) The operation of the above electrical parts must be carried out by qualified electricians under safe conditions (cut off the power supply). And other parts are not allowed to disassemble, otherwise the consequences shall be borne by the user;**

**(2) When the equipment has a failure which is not listed above, and the operator can not immediately rule out, please immediately notify our maintenance department, for your safety, please do not repair equipment by yourself;**

**(3) The maintenance work of this equipment can only be borne by trained and recognized technical staff;**

**(4) If you need to order parts, please seek help from the technical service department, please specify the model and No. of the fume hood you purchased.**

### 3.3 Label Description

3.2.1 Fuse( protection tube) label (figure 20)



Figure 13

Note: Position of 5A protective tube indication label is directly below the tail plug.

3.2.2 Grounding label



Figure 14

---

## **4. Warranty**

- 1、 The warranty period is 12 months from the date of purchase, excluding lamp, fuse, protective tube.
- 2、 If the failure or damage of the instrument and equipment in the warranty period is caused by user's improper use, we do not undertake repair obligation.
- 3、 After the warranty period, we are responsible for repair, but corresponding repair costs will be charged.
- 4、 The lifespan of the equipment is 8 years, the production date can be seen from the cabinet label.
- 5、 Provide necessary equipment drawings and some of the necessary technical data to the repair unit and repair staff trained and recognized by us.