

Biological Safety Cabinet
Class II A2
BSC-1100IIA2-X
BSC-1300IIA2-X
BSC-1500IIA2-X
User Manual

Version 2020.10

Preface

Thank you very much for purchasing our class II A2 biological safety cabinet. Please read the “Operating Instructions” and “Warranty” before operating this unit to assure proper operation. After reading these documents, be sure to store them securely together with the “Warranty” at a hand place for future reference.



Warning: Before operating the unit, be sure to read carefully and fully understand important warnings in the operating instructions.

Content

Preface	1
Content	2
1. Unpacking, Installation, Debugging	4
1.1 Unpacking	4
1.2 Accessories checking.....	5
1.3 Installation conditions and using environment.....	6
1.4 Installation	7
1.5 Checking after installation.....	12
2. User Instructions	13
2.1 Functions	13
2.1.1 Product Concept.....	13
2.1.2 Application Range.....	13
2.1.3 Working theory/Air flow pattern and protected area	13
2.1.4 Protected objects	13
2.1.5 Technical Parameters	14
2.1.6 Performance Index	14
2.2 Product structure.....	15
2.2.1 Structural composition of BSC-1100IIA2-X	15
2.2.2 Structural composition of BSC-1300IIA2-X	16
2.2.3 Structural composition of BSC-1500IIA2-X	17
2.2.4 Structure introduction	17
2.3 Control panel	20
2.4 Remote Control &Foot switch	21
2.4.1 Remote control.....	21
2.4.2 The use of foot switch.....	23
2.5 Instructions for Operation	23
2.5.1 Normal Operation Notice.....	23
2.5.2 Operation Process	24

2.6. Daily maintenance	24
2.6.1 Preparations before maintenance	24
2.6.2 Clean the cabinet surface	24
2.6.3 Overall maintenance period	25
2.6.4 Maintenance methods	25
2.6.5 Storage conditions.....	25
2.7 Methods and procedures for disinfection	25
2.8 Replacement parts list	27
2.9 Wiring diagram	30
3. Trouble shooting and Labels	32
3.1 Common faults & solution	32
3.1.1 Warning and reminder.....	32
3.1.2 Trouble shooting	32
3.1.3 Simple accessories replacement.....	34
3.2 Label Description	36
4. Warranty.....	38

1. Unpacking, Installation, Debugging

Please firstly check if packing box is in good condition. If the packing box is damaged, please take photos.

1.1 Unpacking

1) Method 1: Use M8 Wrench to unpack



Electric Drill



M8 Sleeve

Picture 1

2) Method 2: Use M8 Wrench to unpack



Picture 2

Rapid unpacking diagram (Picture 3). Disassemble the screws shown in the below Picture, then move the wooden pieces to right and left.

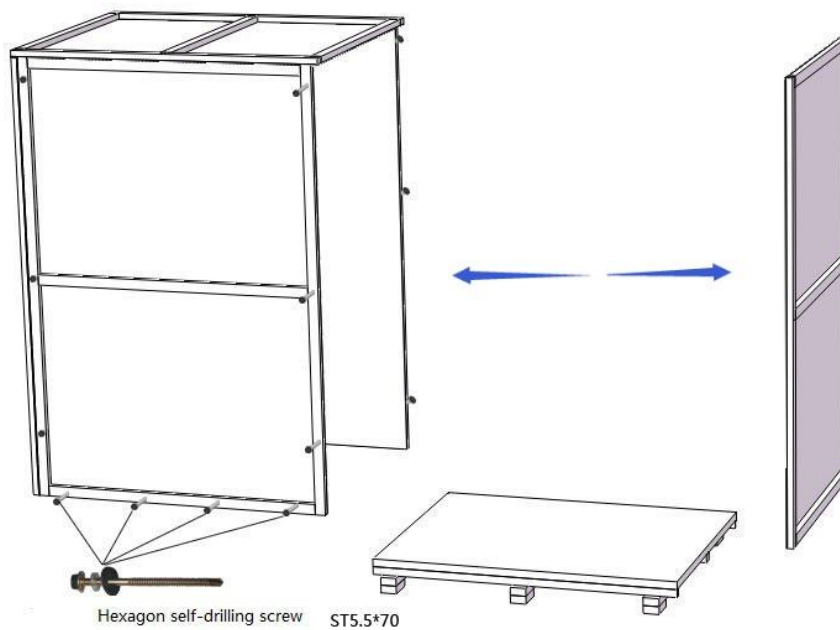

Picture 3

1.2 Accessories checking

Refer to the packing list and check the accessories.

Packing list (BSC-1100IIA2-X/BSC-1300IIA2-X/BSC-1500IIA2-X)

Items	Model	Position	Quantity
Main Body		Wooden box	1unit
Base Stand		Placed in two carton box	1set

UV Lamp (T6 30W)	BSC-1100IIA2-X	Top or back of main body	1pc
	BSC-1300IIA2-X		1pc
	BSC-1500IIA2-X		1pc
Fuse (10A)	BSC-1100IIA2-X	Placed in a transparent plastic bag	1pc
	BSC-1300IIA2-X		1pc
	BSC-1500IIA2-X		2pcs
Fuse (5A)			1pc
Remote control (including battery)			1pc
Keys			2pc
User manual			1pc
Test report			1pc
Quality certification card			1pc
Foot switch			Placed in the carton accessory box
Power cord		1pc	
Drain Valve		1set	
Stainless steel hex cylinder head bolt		3pcs	
Stainless steel flat washer10		3pcs	
Stainless steel spring washer 10		3pcs	
Inner hexagon wrench		1pc	
Big rubber gasket		1pc	
Small rubber gasket		1pc	
Front window tubular motor control rod		1pc	
Buckle stopper (white)		7pcs	

1.3 Installation conditions and using environment

To avoid disturbances to the safety cabinet and its operator, follow the following guidelines, while determining a suitable location for the cabinet:

- a. The distance from the plane of the aperture to any circulation space should be at least 1000 mm, so as to preserve a zone undisturbed by anyone other than the operator.
- b. Biological safety cabinets should be placed in a position where there should be no opposing wall (or other obstruction likely to affect the airflow) within 2000 mm of the front aperture.
- c. Safety cabinets should not be installed in positions where they are likely to be affected by other items or equipment. In particular the distance to the aperture of an opposing safety cabinet, fume cupboard, or the edge of a local exhaust ventilation outlet should not be less than 3000 mm.
- d. Any room air supply diffuser should not be within 1500 mm of the front aperture.

-
- e. Doorways should not be within 1500 mm of the aperture or within 1000 mm of the side of the safety cabinet.
 - f. The position of a safety cabinet should satisfy the spatial requirements (e.g. vision, lighting and convenience of access) of the operator and personnel working nearby. When a cabinet is installed on a bench top, the leading edge should be flush with or slightly overhanging the edge of the bench top.

Working environment:

- (1) Only is suitable for indoor;
- (2) Ambient temperature: 15°C~35°C;
- (3) Relative Humidity: ≤75%;
- (4) Atmospheric pressure range: 70 kPa~106 kPa;
- (5) Electrical parameters: Consistent with the rated voltage of the biosafety cabinet (See 2.1.5 technical parameter performance index);
- (6) Power supply need to be grounded; (Judging method: testing the fire wire and the zero line of the power supply with multimeter, the fire wire to ground voltage should be grid voltage and the zero line to ground voltage should be 0, otherwise the power supply ground is bad).
- (7) Test the voltage stability before using, if the voltage is unstable, should use the voltage regulator, otherwise the control panel and transformer may be easily damaged.

1.4 Installation

- a. Remove all the package materials;
- b. Inspect the surface of main body to make sure whether there is scratch, deformation or uncorrelated things;
- c. Move the whole device to the final installation location;



The base stand will be packed at back of main body, please take it out before installation.

DO NOT INVERT, DISASSEMBLE OR TITLE THE CABINET during transportation.

- d. The base stand assembly

Referring to Picture 4 assemble the base stand.

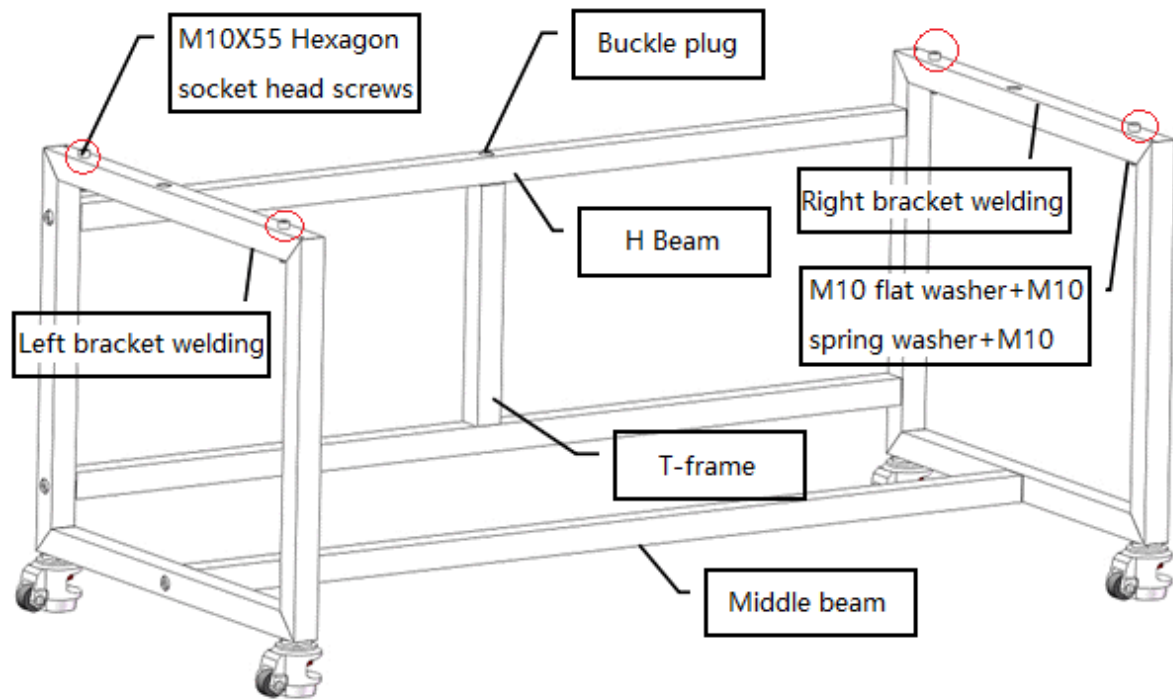

Picture 4

Remove the M10×55 Hexagon socket head screws, Buckle plug, M10 Stainless steel flat washer, M10 Stainless steel spring washer, M10 Stainless steel cap nuts, referring to Picture 4 assembled base, firmly fastening requirements.

e. Connect base stand and main body

Refer to Picture 5, 6 to connect base stand and main body.

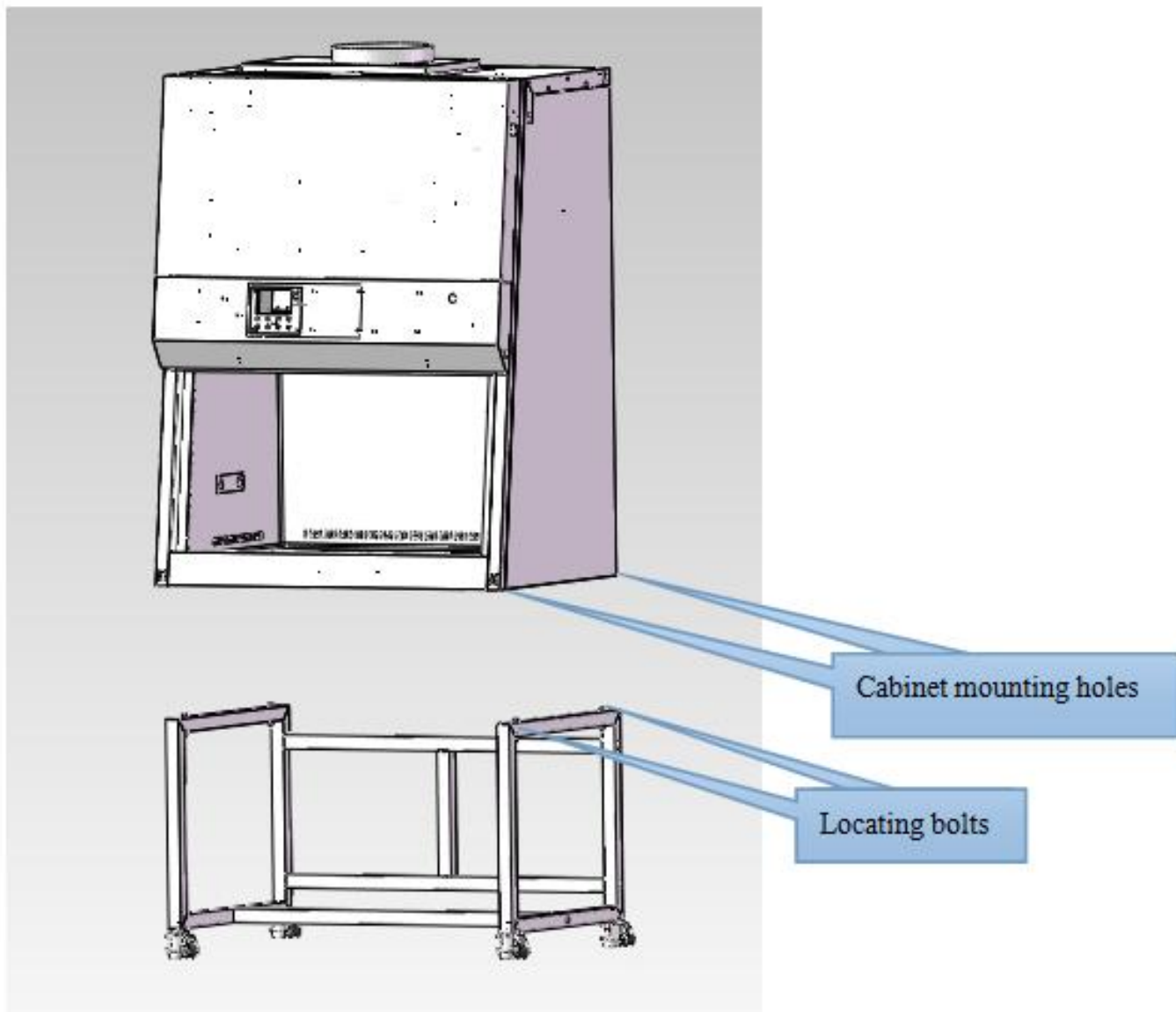

Picture 5

Align the mounting holes on the bottom of the cabinet with the mounting bolts, and the cabinet slowly descending the mounting base.

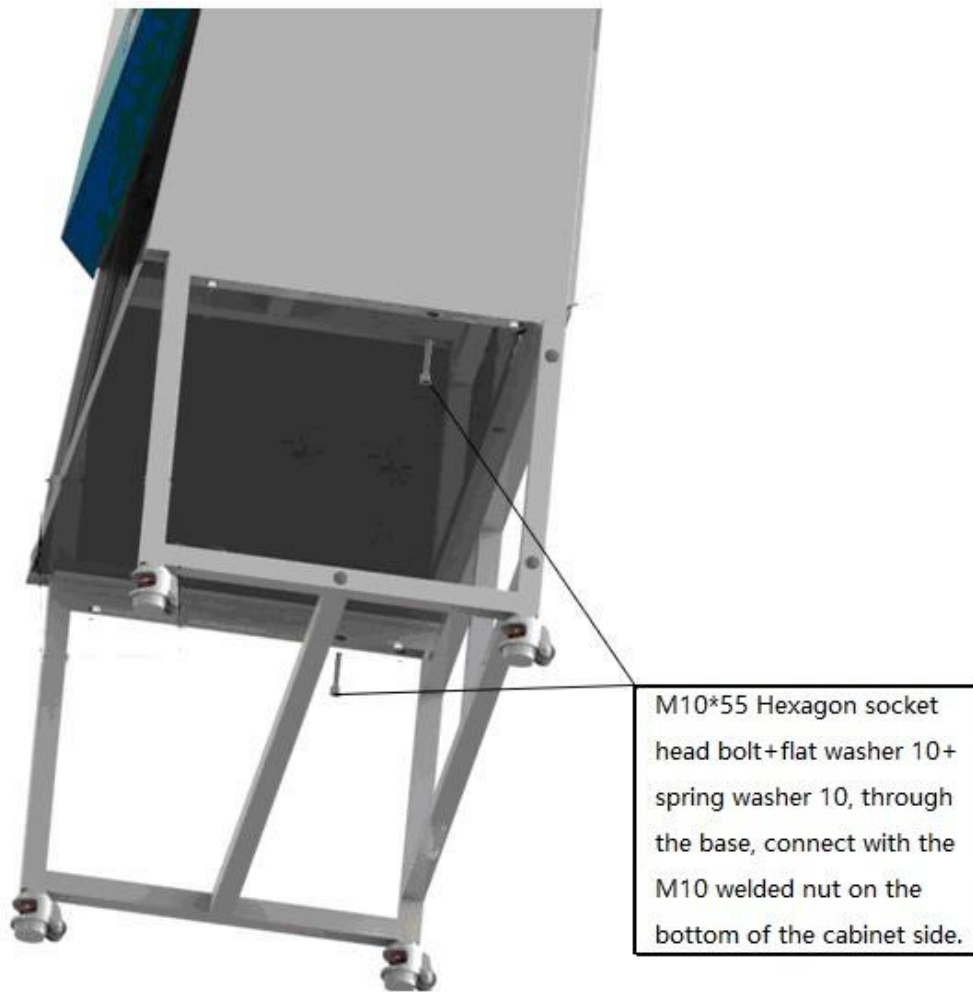

Picture 6

Take out the M10*55 Hexagon socket head screws, Flat washer 10, Spring washer 10 from the accessory box, and fasten tightly according to Picture 6.

f. Installation of Drain valve

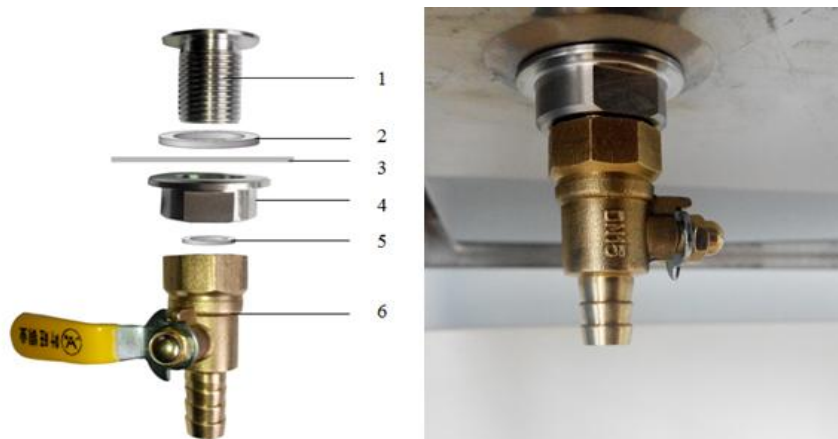

Picture 7

1. Drain valve connect
2. Shim (Inner diameter*outer diameter*thicknessΦ20*Φ28*2mm)
3. Safety cabinet bottom installation holes

-
4. Ball coupling fastening nut
 5. Rubber gasket (Inner diameter*outer diameter*thickness $\Phi 13*\Phi 19*2\text{mm}$)
 6. Drain valve

Take out drain valve coupling, shim, Ball nut, Rubber gasket, Drain valve, assembling from up to down as Picture 7 illustrated.

g. Adjustment of Footmaster Caster

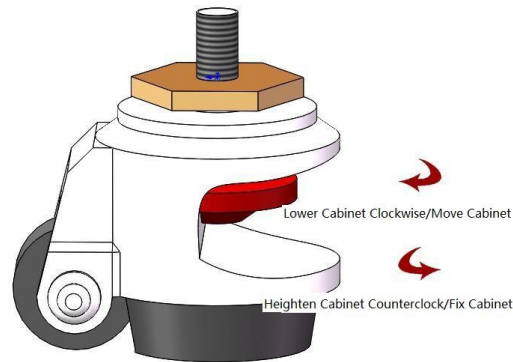

Picture 8

Clockwise rotate caster' red part to low down the base feet and the height of the cabinet. Low down all four casters can move the cabinet position. Counterclockwise rotate casters' red part can rise the base leg and height of cabinet. Raise all four casters can at same time can fix the cabinet. Adjust the four Foot -masters makes the cabinet stable.

h. Foot Switch

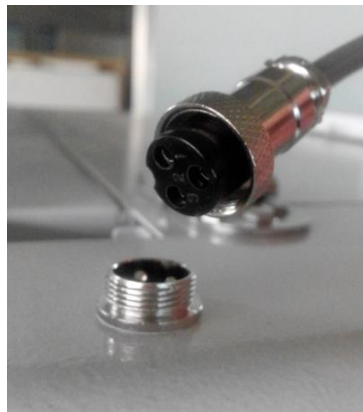

Picture 9

Install Foot Switch as Picture 9. It's socket is at the left top, connect the plug.

i. Installation of Water and Gas Tap (Optional)



Picture 10

1. Fastening Nut
2. Stainless Steel Water and Gas Taps

Take out fastening nuts, water and gas taps, installing as Picture 10.

1.5 Checking after installation

First, make sure the Voltage and frequency to be same as logo showing, and then check the follows items with power on:

Checking Items	Normal situation
Wind speed display	Inflow $0.53 \pm 0.025 \text{m/s}$, downflow $0.33 \pm 0.025 \text{m/s}$
Pressure display	exhaust filter 80-120Pa, downflow filter 80-120Pa
Fan running	Normally
LED lamp	Lamp lights after pressing button
UV Lamp	Lamp lights after pressing button
Display screen buttons	All buttons can be used
Socket	Press the socket key, multimeter testing output supply voltage
Foot Switch	Red pedal for glass up, black pedal for glass down

2. User Instructions

2.1 Functions

2.1.1 Product Concept

This products belong to Class II A2 biological safety cabinet which fully meet the requirement of US standard ANSI/NSF49:2002, European standard EN12469:2000, biological safety cabinet is a kind of negative pressure filtration system for protecting operator, the laboratory environment and work materials, the front opening which air flow inward have protection function for operator, the filtered laminar flow generated by vertical ULPA can protect work materials, what's more, the polluted air flow become pure after processed by ULPA(ULPA) filter. When it's used in microbiology experiment environment filled with volatile or toxic chemical and radionuclide, suitable exhaust hood in function have to be linked.

2.1.2 Application Range

Biological Safety Cabinet is necessary equipment in the laboratory in the search of microbiology, biomedical, DNA recombinant, animal experiment, and biological products, especially in the occasion that operator need to adopt protective measure, such as medical and health, pharmacy, medical research. Our equipment provides a safety working environment which don't have bacterial and dust in the process of bacterial culture.

2.1.3 Working theory/Air flow pattern and protected area

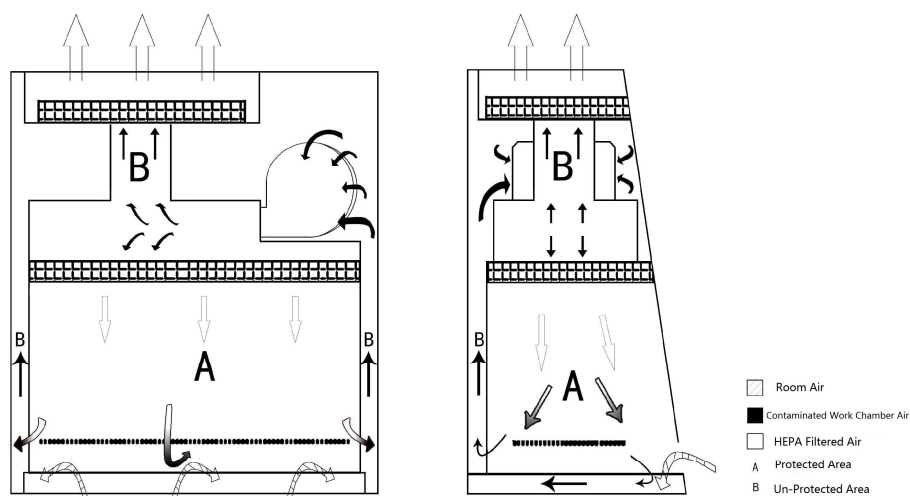

Picture 11

2.1.4 Protected objects

Biological safety cabinets (BSCs) are designed to protect the operator, the laboratory environment and work materials from exposure to infectious aerosols and splashes that may be generated when manipulating materials containing infectious agents, such as primary cultures, stocks and diagnostic specimens.

2.1.5 Technical Parameters

Model Parameters	BSC-1100IIA2-X <input type="checkbox"/>	BSC-1300IIA2-X <input type="checkbox"/>	BSC-1500IIA2-X <input type="checkbox"/>
Product Standard	Meet US standard ANSI/NSF49:2002, European standard EN12469:2000 Standard		
Power Supply AC	220V±10% <input type="checkbox"/>	110V±10% <input type="checkbox"/>	
Frequency	50 Hz <input type="checkbox"/>	60Hz <input type="checkbox"/>	
External Size(W*D*H)	1100×750×2250 mm	1300×750×2250 mm	1500×750×2250 mm
Working Zone Size(W*D*H)	940×600×660 mm	1150×600×660 mm	1350×600×660 mm
Consumption	760W	800W	900W
Total Airflow Volume	360m ³ /h	440m ³ /h	500m ³ /h
UV Lamp Consumption	30W	30W	40W
LED lamp Consumption	12W*2	12W*2	16W*2
Downflow Velocity	0.33±0.025m/s		
Inflow Velocity	0.53±0.025m/s		
ULPA Filter	≥99.9995%(Diameter: 0.12μm)		
Noise	≤67dB (A)		

Notes: (1) Electric consumption power including power which operation area needs to load (Loading no more than 500W)

(2) Our company has right for changing the products, if we need to change and re-design, please forgive us for not notifying you.

2.1.6 Performance Index

1) Biological safety functions

Personnel protection, microbial colony count ≤5CFU;

Sample protection, microbial colony count $\leq 5\text{CFU}$;

Cross contamination protection, microbial colony count $\leq 2\text{CFU}$.

2) Leak-proof Cabinet

If cabinet pressurized to 500Pa, the pressure should be no less than 450 Pa after 30 min.

3) Integrity of ULPA Filter

Scan and detect the ULPA filter, the leakage rate at any point should not be $>0.01\%$.

4) Vibration amplitude

The net vibration amplitude between frequency 10Hz and 10KHz is no more than $5\mu\text{m}(\text{rms})$.

5) Illumination

The average illumination is no less than 650 lux, actual illumination is no less than 430 lux.

6) Mechanical performance

Structure design is reasonable, high quality materials are adopted for the cabinet.

It can resist shape global deformation caused by external force.

The working surface will not occur permanent deformation when weight put reaching 23kg.

7) Electrical properties

The voltage increases to 1390V(AC) in 5s and keep for another 5s without breakdown.

Grounding resistance $\leq 0.1\Omega$

2.2 Product structure

2.2.1 Structural composition of BSC-1100IIA2-X

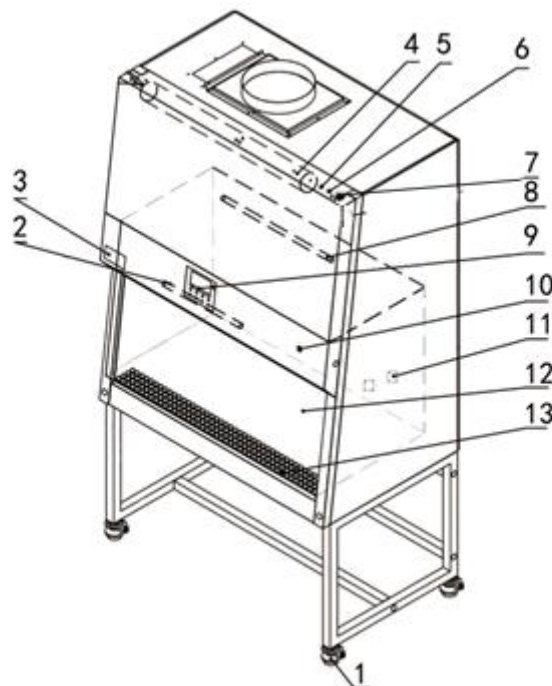

Picture 12

1. Footmaster Caster

2. LED Lamp

3. Nameplate

4. Tube motor

5. Fuse socket

6. General power fuse socket

- 7. Power socket
- 8. UV lamp
- 9. Control panel
- 10. Power supply lock

- 11. Water-proof socket
- 12. Front window
- 13. Inflow grid

2.2.2 Structural composition of BSC-1300IIA2-X

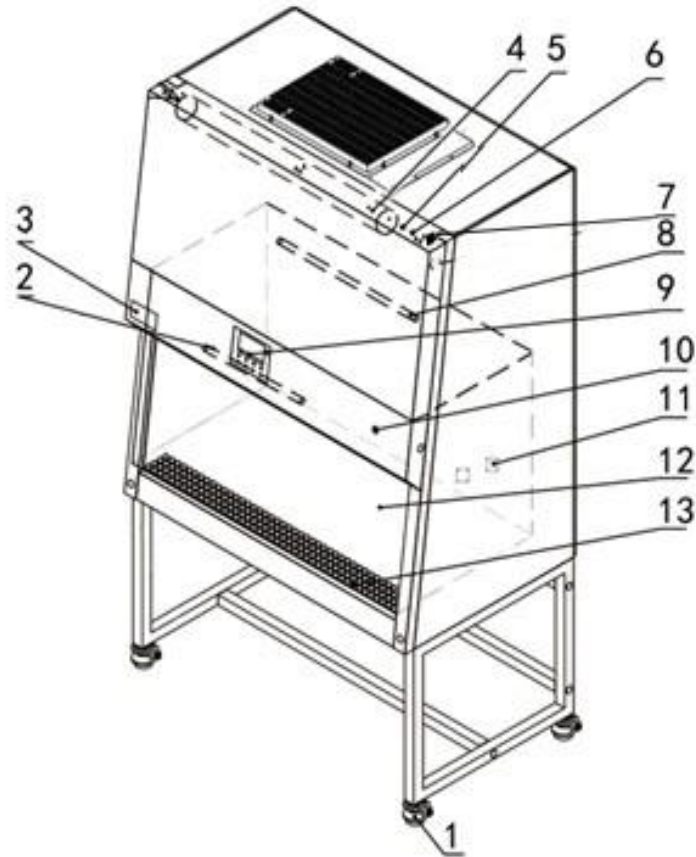

Picture 13

- 1. Footmaster Caster
- 2. LED Lamp
- 3. Nameplate
- 4. Tube motor
- 5. Fuse socket
- 6. General power fuse socket
- 7. Power socket

- 8. UV lamp
- 9. Control panel
- 10. Power supply lock
- 11. Water-proof socket
- 12. Front window
- 13. Inflow grid

2.2.3 Structural composition of BSC-1500IIA2-X

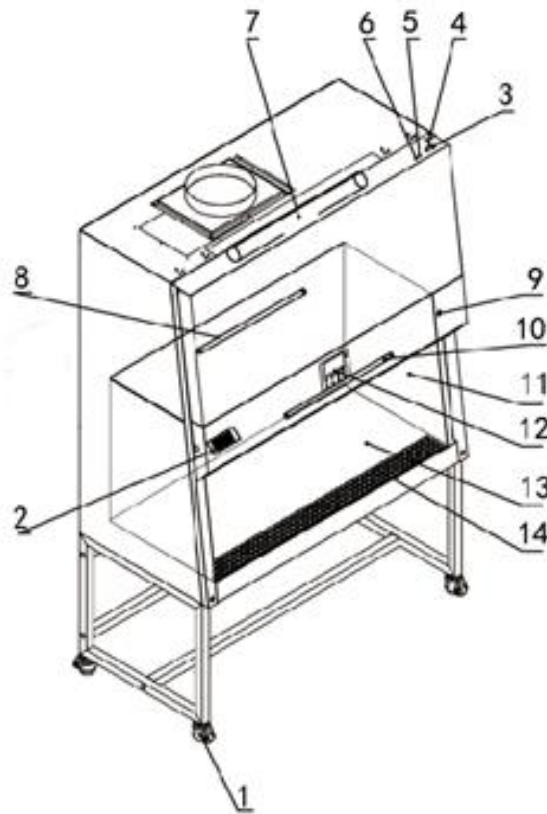

Picture 14

- | | |
|------------------------------|------------------------|
| 1. Footmaster Caster | 8. UV lamp |
| 2. Nameplate | 9. Power supply lock |
| 3. Power socket | 10. LED Lamp |
| 4. General power fuse socket | 11. Water-proof socket |
| 5. Fuse socket | 12. Control panel |
| 6. Blower fuse tube socket | 13. Front window |
| 7. Tube motor | 14. Inflow grid |

2.2.4 Structure introduction

1) Driving System of Front Window

Driving system consists of tube motor, front window, hauling sash and position switch.

2) Air Filtration System

Air Filtration System is the most important system of BSC. It consists of blower, supply filter and exhaust filter. The function of Air Filtration System is transferring filtered air to work area, ensure the down flow velocity, and keep Class 100 cleanness of work area.

3) UV Light

UV lamp is inside work area. So UV lamp can well sterilize all space of work area.

4) LED Light

The BSC is equipped with LED lamp. It can make sure average illumination inside work area which meets standard requirements.

5) Air pipe

Air pipe is the ventage of differential pressure sensor.

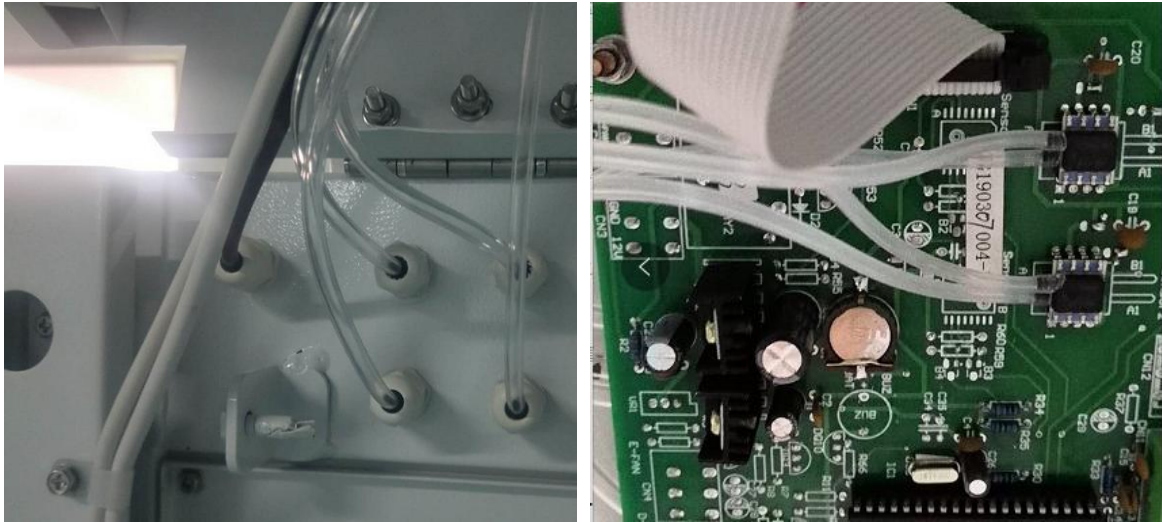

Picture 15

⚠ The air pipe should not be blocked and please do not hang anything on the pipes, otherwise it will effect wind speed and pressure.

6) Power lock

When the power cord is connected to main power, switch the key for power lock, then the equipment is powered on.

7) Water proof Socket

Waterproof Sockets are located on the right side of the work area, which can be controlled by SOCKET button.

⚠ (1) Please make sure the total load of sockets should be $\leq 500W$;

(2) The waterproof socket can only be waterproof when its front cover is lowered, and the socket can not be regarded as a waterproof socket when the front cover is opened.

8) Fuse protector:

The equipment is equipped with main power fuse, waterproof socket fuse and fan fuse (only for BSC-1500IIA2-X). They are located near the power cord's outlet. Fuse label is corresponding to the relevant specifications. Please refer to 3.2.

9) LCD Display (Liquid Crystal Display)

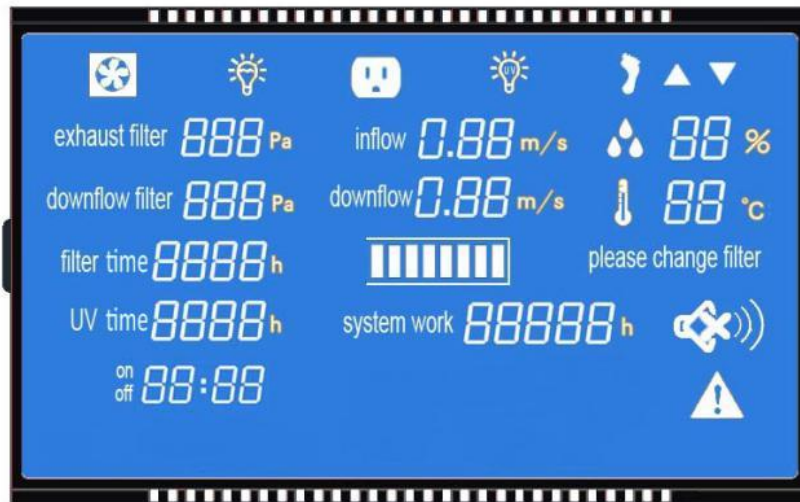

Picture 16

Large LCD display indicates detailed key parameters, it is real-time display to reflect the equipment working condition, such as effective working state of the filter, which is more intuitive. (Please refer to 2.3)

10) Control of Front Window

Front window is motorized. It could be controlled by control panel. Glass door control motor for a dedicated reversible speed motor, the motor has a large starting torque, smooth rotation and so on.

11) Structure

- a) Biological Safety Cabinet's both sides and back area are negative pressure air channel. Make a double isolation by air curtain and cabinet between working area and external environment And the working area surrounded by negative pressure to avoid any leakage.
- b) Cabinet body is built of 1.2mm cold-rolled steel with anti-powder coating. Strong and steady.
- c) Work area is fully made of 304 stainless steel which looks beautiful and with corrosion resistance performance.
- d) Base stand is made of cold-rolled steel with anti-powder coating.
- e) Soft touch type control panel, easy to handle and beautiful appearance.

2.3 Control panel

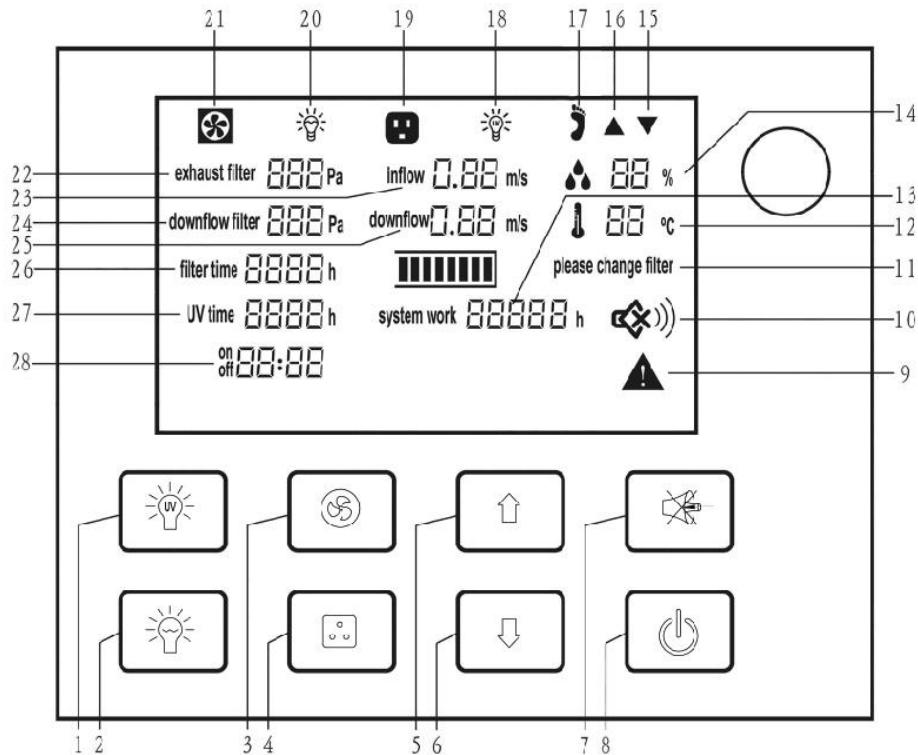

Picture 17

- | | |
|------------------------------|--|
| 1. UV Lamp | 2. LED Lamp |
| 3. Fan | 4. Socket |
| 5. Glass Window Up | 5. Glass Window Down |
| 7. Mute | 8. Power |
| 9. Alarm Status | 10. Mute Status |
| 11. Filter Changing Status | 12. Temperature |
| 13. System Working Time | 14. Humidity |
| 15. Glass Window Down Status | 16. Glass Window Up Status |
| 17. Foot Switch Status | 18. UV Status |
| 19. Socket Status | 20. LED Lamp Status |
| 21. Fan Status | 22. Exhaust Filter Differential Pressure |
| 23. Inflow velocity | 24. Supply Filter Differential Pressure |
| 25. Down-flow velocity | 26. Filter Working Time |
| 27. UV Lamp Working Time | 28. Reservation Timing |

a) LCD Screen

The working status of the equipment and operation can be seen on the LCD screen.

b) Soft touch button.

BSC's main functions could be executed by touch-buttons. User can operate the BSC either by pressing the buttons on control panel or using the remote control. There are totally 8 common button on control panel.



: The power button, the main switch to control other functional keys



: To control LED lamp



: To control UV lamp. (It works only after front window, LED lamp and blower fan are fully closed.)



: To control blower working status. (It will not work when front window is fully closed.)



: To control socket power status.



: Press MUTE button to stop voice prompt



: Press UP button, glass window will raise.



: Press Down button, glass window will fall down.

There are totally 8 common button on control panel.

Clock Adjustment:

Turn the power key, so machine is in standby state.

Press the light button, and then press the power button for 5 seconds. Then you see the state of clock adjustment after a buzzer alarm.

Firstly, minute position is flashing, press UP and DOWN to adjust to present time. Then press the MUTE button switching to hour position and adjust to present time. After that, press the light button first, and press the power button for about 5 seconds. Data will be saved after a buzzer alarm.

2.4 Remote Control &Foot switch

2.4.1 Remote control

It is inconvenient for the users to operate from a distance. Small & light remote control is flexibly to be used to control all the functions of the cabinet in a distance $\leq 6\text{m}$, 30° range. The operator can even carry it with themselves during experiment for convenience.

This remote control adopt specific chip which is featured with good anti-jamming performance, longer control distance and high control precision.

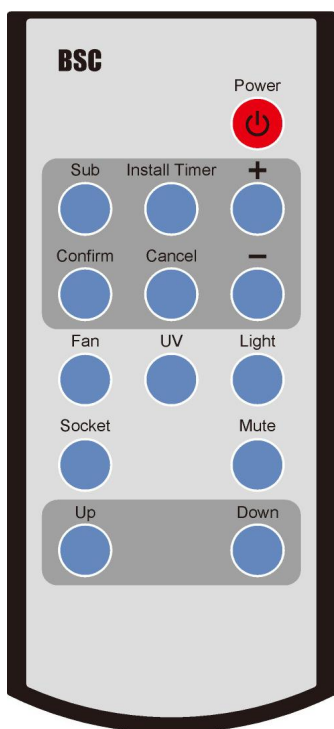

Buttons of Remote Control:

1. Power (POWER)
2. Reservation Time (SUB)
3. Timer (INSTALL TIMER)
4. Confirm (CONFIRM)
5. Cancel (CANCEL)
6. Turn up (+)
7. Turn down (-)
8. Fan (FAN)
9. UV (UV)
10. Illumination (LIGHT)
11. Socket (SOCKET)
12. Mute (MUTE)
13. Front window up (UP)
14. Front window down (DOWN)

Picture 18

A. Reservation Time (SUB)

- a. Connect power, open power lock, and press the reservation timing button (SUB);
- b. Adjust the time (minutes) by “+” or “-” button. Press the confirmation button (CONFIRM) to confirm; and then adjust other minutes and hours position data in the same way;
- c. After the time is confirmed, the corresponding display lamp lights by selecting the function buttons (such as UV);
- d. Press the POWER button again, the reservation function starts. Reserved time starts count down. The corresponding setting function starts when the time counts down to zero.

B. Timer (INSTALL TIMER)

- a. Connect power, open power lock, press button (POWER), the corresponding display lamp lights by selecting the function buttons (such as UV);
- b. Press button (INSTALL TIMER), adjust the time (minutes) by “+” or “-” button. Press button (CONFIRM) to confirm; and then adjust other minutes and hours position data in the same way;
- c. After the time is confirmed, the Timer function starts. When the time counts down to zero, all the functions will be off, the cabinet will be in standby mode.

C. Application of Reservation Time

Biological safety cabinet is equipped with special UV lamp. When turning on or turning off the cabinet, sterilization time of UV lamp should be at least 30 minutes. In order to save the waiting time of turning on or turning off the cabinet, we develop reservation time function. It realizes function of automatic turning on or turning off the cabinet after the sterilization finished. Reservation time setting range is from 0 to 99 hours and 59 minutes. This function helps operators to save time and improve efficiency.

2.4.2 The use of foot switch



Picture 19

Press the left red switch by foot, front window goes up, press the right black switch, front window goes down.

2.5 Instructions for Operation

2.5.1 Normal Operation Notice

- (1) Make sure input voltage is correct and stable. The rated load of main power socket should be higher than cabinet consumption. Plug must be well grounded.
- (2) In order to avoid air turbulence, the operator should slightly move his arms during experiment. Hands should stay inside the working area at least 1 minute before operating. In order to decrease the times of arms moving into and out of the working area, prepare all the necessary items inside the cabinet before starting experiment;
- (3) Moving principles of different samples inside cabinet: When two or more samples need to be moved, be sure that low-polluting samples move to high-polluting samples. Movement of items should also follow the principles of slow-moving.
- (4) Samples placed in parallel: Samples should be placed in the cabinet parallel to avoid cross-contamination between samples and blocking back air grille.
- (5) In order to avoid samples being sucked into the negative passage or the blower, do not place soft and slight samples (for example: soft tissue) on the surface during experiment;
- (6) The weight of items placed in the cabinet should be no more than 23Kg/25×25cm²;
- (7) Avoid vibration: avoid using vibration equipment (eg centrifuges, vortex oscillator, etc.) inside the cabinet. Vibration would cause lower cleanliness of operating area and affect operator protection.
- (8) No flame: No flame is allowed inside the cabinet. Using of fire will lead to airflow disorder, and filter damage. If sterilization is required during the experiment, infrared sterilizer is highly recommended.
- (9) ULPA filter life: With the usage time increasing, dust and bacteria accumulate inside ULPA filter. Filter Resistance is getting bigger, when it reaches the maximum point, there will be audible and visual alarm. Please replace new ULPA filter, otherwise it will affect the safety performance of the equipment. The used filter should be processed as medical waste.
- (10) There is a negative passage surrounding the work area, which is sealed strictly in the factory. The operator is not allowed to remove or loose screws of those parts. If necessary, please contact service personal.
- (11) Front Grille is used for air intake and drain. Do not block it, otherwise it will affect airflow. Armrest is recommended to solve this problem and reducing the operator's wrist fatigue.
- (12) Long-term use of biological safety cabinets will inevitably cause pollution (e.g. ULPA filters,

corner cabinets, etc.). In order to sterilize thoroughly every 500 hours, formalin (formaldehyde) fumigation sterilizer is recommended. After sterilization, neutralize formaldehyde gas with ammonium hydrogen carbonate. Make sure no sterilization gas escapes during the whole process.

- (13) The maximum storage period is one year. If the period is more than one year, performance test should be done .



Serious declaration: we will take no responsibility for risks caused by improper operation and man-made damages!

2.5.2 Operation Process

- a. Connect the same power reply, as required of equipment
- b. Open the power lock, LCD display lights up and alarm rings at the same time, then the machine enters to standby status. Waiting for the operator to input button to use it.
- c. Press POWER button, then the following functions are available: LED lamp, UV lamp, Fan, Mute, Sockets, Front window up and down, Reservation timing



When front window is open or other button is pressed, the UV lamp can not be work.

- d. Before doing experiment, please sterilize the cabinet for more than 30 minutes by UV lamp(the front window must be closed)



(1) For safety of eyes and skin, people should leave room during the UV sterilization.

(2)UV lamp intensity should be tested regularly. If there is no test conditions, it should be replaced, recommend once for three month.

- e. Please move the front window at 200mm height from the work table, turn on the fan, make sure the experiment should be started after fan working for at least half an hour.



For operating safety, please put testing materials inside the cabinet in advance, and keep the front window at 200mm height from the work table during operation.

After finishing the experiment, please move the front window down to the bottom, and make sure to sterilize the cabinet by UV lamp for 30 minutes before turning off the cabinet.

2.6. Daily maintenance

Because the operating time will directly affect the judgment of maintenance needs, we recommend the user keep a detailed record of operating time for reference.



When doing maintenance, please pay attention to cut off the power, so as to avoid electric shock

2.6.1 Preparations before maintenance

Soap, hot water or warm water, a soft cotton cloth, dry cloth or towel, medical alcohol or other disinfectants, 100 dilution of household bleach, abrasive household cleaners, sterile water

2.6.2 Clean the cabinet surface

1) Clean the operating area surface

Wipe the entire surface with a soft cotton cloth or towel soaked with concentrated liquid soap, then wipe up the soap with another cotton cloth or towel soaked with clean hot or warm water, and then

wipe the surface with a dry cotton cloth or towel rapidly.

For the contaminated or dirty work surface or sump., use 70% medical alcohol or other disinfectant to wipe.



Disinfectants used for wiping should not damage 304 stainless steel.

2) **Clean the external surface and front window.**

Use soft cotton cloth or towel to wipe the surface with non-abrasive household cleanser.

2.6.3 Overall maintenance period

We suggest comprehensive maintenance period is one year or 1000 working hours.

2.6.4 Maintenance methods

1) **Daily or weekly maintenance**

- a. Disinfect and clean operating area;
- b. Clean the external surface and front window around the operating area;
- c. Check the various functions of equipment;
- d. Record this maintenance result

2) **Monthly maintenance**

- a. Clean the the external surface and front window.
- b. Wipe the working table, inner wall surface of operating area (excluding the wind distributing grid of operating area) and the inner surface of glass door with 70% medical alcohol or household bleach diluted 1:100 (i.e, 0.05% sodium hypochlorite). Then wipe again with sterile water in order to eliminate the rest chlorine.
- c. Check the various functions of equipment;
- d. Record this maintenance result;

3) **Annual maintenance**

- a. Check the two conveyor belts of front window drive unit, and ensure that their tightness is coincident.
- b. Check the UV lamp and LED lamps.
- c. Apply for testing the overall performance of cabinet on an annual basis to ensure the performance safety. User is responsible for testing costs.
- d. Record this maintenance result.

2.6.5 Storage conditions

Safety cabinet should be stored in a relative humidity no more than 75%, the temperature is below 40°C, in the warehouse with good ventilation performance, no acid, no alkali and no other corrosive gases, storage period shall not exceed one year, safety cabinet for more than a year needs to unpacked and checked. Only the tested and qualified safety cabinet can be sold.

2.7 Methods and procedures for disinfection

Details in the After-sale service manual

Disinfection is necessary when any contaminated part of the biosafety cabinet needed for routine maintenance, replacement filters, and performance testing, etc. Before doing certification test and gas sterilization, all internal working surface and the exposed outer surface should be disinfected with a suitable disinfectant. what is more, using Class II biosafety level designated medicament to sterilize the cabinet by gases is required. Class III biosafety level designated medicament is recommended after the use of the cabinet. The cabinet, under the risk of being polluted by the biological factor,

should be sterilized before sliding position.

The polluted working surface caused by overflowed and spilled reagents also should be sterilized. Most of the cases that need gas sterilization use depolymerized triformol as the disinfectant as noted below, the period parameters and its validity of each model and size of the cabinet are required to be listed before change sterilization method. The relevance of the material has connections with the absorption and degeneration of spare decontaminant, which is the key factor of keeping the cabinet integrated and the sterilization time. There need those alternative sterilization way in some case, such as: slow disease virus. The sterilization method is used against the consult between the end user and certification authority. Pointing out the given area, gas mask, safeguard procedures, corresponding test, medical monitoring, conveying danger and training, record and reserve etc... and follow these steps.



Before sterilization, all the hydrogen chloride should be moved away from the cabinet. There will result in carcinogenic substance-BCME when it meet with formaldehyde under the ambient air.

- a. Figure out the total volume by multiplying the height, width and depth.
- b. The required weight of the triformol will be worked out through the total volume multiply 11g/m^3 , figuring out the weight of ammonium bicarbonate or its alternative by chemometry.
- c. It must be bubble-tight if there are exhaust pipe with the biosafety cabinet, which can be realized at the end of the pipe or sealing at the control valve if there is valve nearby the cabinet, it need more triformol to compensate the added volume if the length of exhaust pipe is more than 3 meters. If the exhaust recirculation of the cabinet connect with the exhaust system of the construction, interrupting the connection system of the biosafety cabinet with construction and sealing (by using plastic film and plastic strips)
- d. Sealing by plastic film as the waste gas is exhausted into the room from biosafety cabinet.
- e. In order to urgently eliminate formaldehyde, sterilize and eliminate formaldehyde after neutralizing, putting a tube nearby the biosafety cabinet in advance which is required to connect with chemical smoke hood or other exhaust devices that is suitable for releasing the harmful gas.
- f. Put the heater, such as electric-heating frying pan which can be bought from market, formaldehyde generator or neutralizer on the working table. Set up the temperature at $232^{\circ}\text{C}\sim 246^{\circ}\text{C}$, the triformol is spraying over the surface of the heater devices equably.



- g. The autoignition temperature is paraformaldehyde at 300°C .
- h. The neutralizer with the heating device is placed on the workbench. Neutralizers (Ammonium bicarbonate or equivalent) should be isolated from the air in the cabinet before use. The following two examples illustrate how to achieve air separation.
- i. Eg.1
- j. Ammonium bicarbonate or substitute is uniformly sprayed on the heated surface of the heating device and covered with aluminum foil to prevent the carbonic acid hydrogen ammonia or its substitute in disinfection reaction with formaldehyde. The aluminum foil should be placed so that ammonia can be released during heating or ready to remove aluminum foil at the beginning of the neutralization phase. Removal of aluminum foil is not allowed when the formaldehyde leakage out of the safety cabinet of;

Eg.2

The safety cabinet with the gloves for a whole plastic film sealing. Ammonium bicarbonate or equivalent substitutes are placed in a container in a safety cabinet. During the neutralization phase, the disinfected personnel into the safety cabinet through the gloves do not break the sealing system. The ammonium bicarbonate or equivalent substitutes are removed from the sealed container and uniformly sprinkled on the heating surface of the heating device, then the heating device is energized, the ammonium bicarbonate or the substitute is heated to release the ammonia.

- k. Putting heating plate, water beaker and hygrothermograph on the work table, do not connect the wires to the power supply in the cabinet.
- l. Sealing the front operating window with thick plastic film and plastic strips. Seal all the area where possible to leak. Such as wire outlet, the surrounding of front operating window and joint between plastic film and biosafety cabinet.
- m. Measure the temperature and humidity inner the cabinet.
- n. The humidity is at 60%~85% when temperature is above 21°C, heating the water in the beak up to the expected temperature and humidity.
- o. Before depolymerizing the formaldehyde, strictly restrict entry to the area around biosafety cabinet or room in accordance with related regulation and safety measures.
- p. Connect the wire of the heater with socket outside the cabinet.
- q. 25% formaldehyde is depolymerized open the safety cabinet fan 10 s ~ 15 s.
after the para-formaldehyde is depolymerized by 50%, 75% and 100%, repeating the above steps. If the safety cabinet fan does not work, Use auxiliary fans to promote air circulation in the cabinet, or prolong the disinfection time over Step P.
- r. Disconnect the power supply of the heating plate and heater for the use of triformol
- s. Keep the biosafety cabinet isolation at least 6 hours, it is better to leave it for a night.
- t. Prepare the neutralizer, power off the heating device and the fan of biosafety cabinet until ammonium bicarbonate wiped away, the operation of triformol is also the same, after the decomposition of 20% ammonium bicarbonate, open the fan for 10 s~15 s, using assisted fan or electric fan to promote the air circulation inner biosafety cabinet or prolong the neutralization time for at least 6 h if the fan of the biosafety cabinet does not work.
- u. Keep the biosafety cabinet isolation at least 1 hour before open the sealing membrane;
- v. If exhausting the formaldehyde caused by neutralization via tube, tear out the plastic cover in the exhaust pipe, connect it with tube and seal. The plastic cover in the front of the biosafety cabinet will be suck in and cut one or two openings make the fresh air be into the cabinet if the tube work well, then the formaldehyde is exhausted via tube.

2.8 Replacement parts list

BSC-1100IIA2-X replacement parts list

Number	Name	Specification
AAQ01	Fuse	10A
AAQ02	Fuse	5A

AAQ03	Lamp holder T8	LG13-01A
AAQ05	UV Lamp	T6 30W
AAQ06	LED Lamp	T5 12W LED
AAQ07	UV lamp ballast	1*TL8-30W
AAQ08	Upper filter (Exhaust filter)	800*420*69mm
AAQ09	Lower filter (Supply filter)	925*470*69mm
AAQ10	Fan	FS133Q
AAQ11	Control panel	LCD control board (strong circuit board, weak circuit board, display screen)
AAQ12	Remote control (with battery)	
AAQ13	Key selection button	LA42YZP-20B
AAQ14	Glass	1034*730*6.38mm
AAQ15	Foot switch	Dual pedal (line length 4 meters)

BSC-1300IIA2-X Replacement parts list

No.	Designation	Standard
AAP01	Fuse	10A
AAP02	Fuse	5A
AAP03	lamp holder T8	LG13-01A
AAP05	UV Lamp	T6 30W
AAP06	LED lamp	T5 12W LED
AAP07	UV lamp ballast	1*TL8-30W
AAP09	Upper filter (Exhaust filter)	850*420*69mm
AAP10	Downflow filter (Supply filter)	1190*470*69mm
AAP11	Fan	FH355A
AAP12	Control panel	LCD control board (strong circuit board, weak circuit board, display screen)
AAP13	Remote control (with battery)	
AAP14	Key selection button	LA42Y2P-20B
AAP15	Glass	1237*730*6.38mm
AAP16	Foot switch	Dual pedal (line length 4 meters)

BSC-1500IIA2-X Replacement parts list

No	Designation	Standard
AAJ01	Fuse	10A
AAJ02	Fuse	5A
AAJ03	Lamp holder T8	LG13-01A
AAJ05	UV Lamp	T6 40W
AAJ06	LED Lamp	T5 16W LED
AAJ07	UV lamp ballast	1*TL8-36W
AAJ09	Upper filter (Exhaust filter)	920*420*69mm
AAJ10	Downflow filter (Supply filter)	1380*470*69mm
AAJ11	Fan	FH230
AAJ12	Control panel	LCD control board (strong circuit board, weak circuit board, display screen)
AAJ13	Remote control (with battery)	
AAJ14	Key selection button	LA42Y2P-20B
AAJ15	Glass	1419*720*6.38mm
AAJ16	Foot switch	Dual pedal (line length 4 meters)

2.9 Wiring diagram

BSC-1100IIA2-X Wiring diagram/BSC-1300IIA2-X Wiring diagram

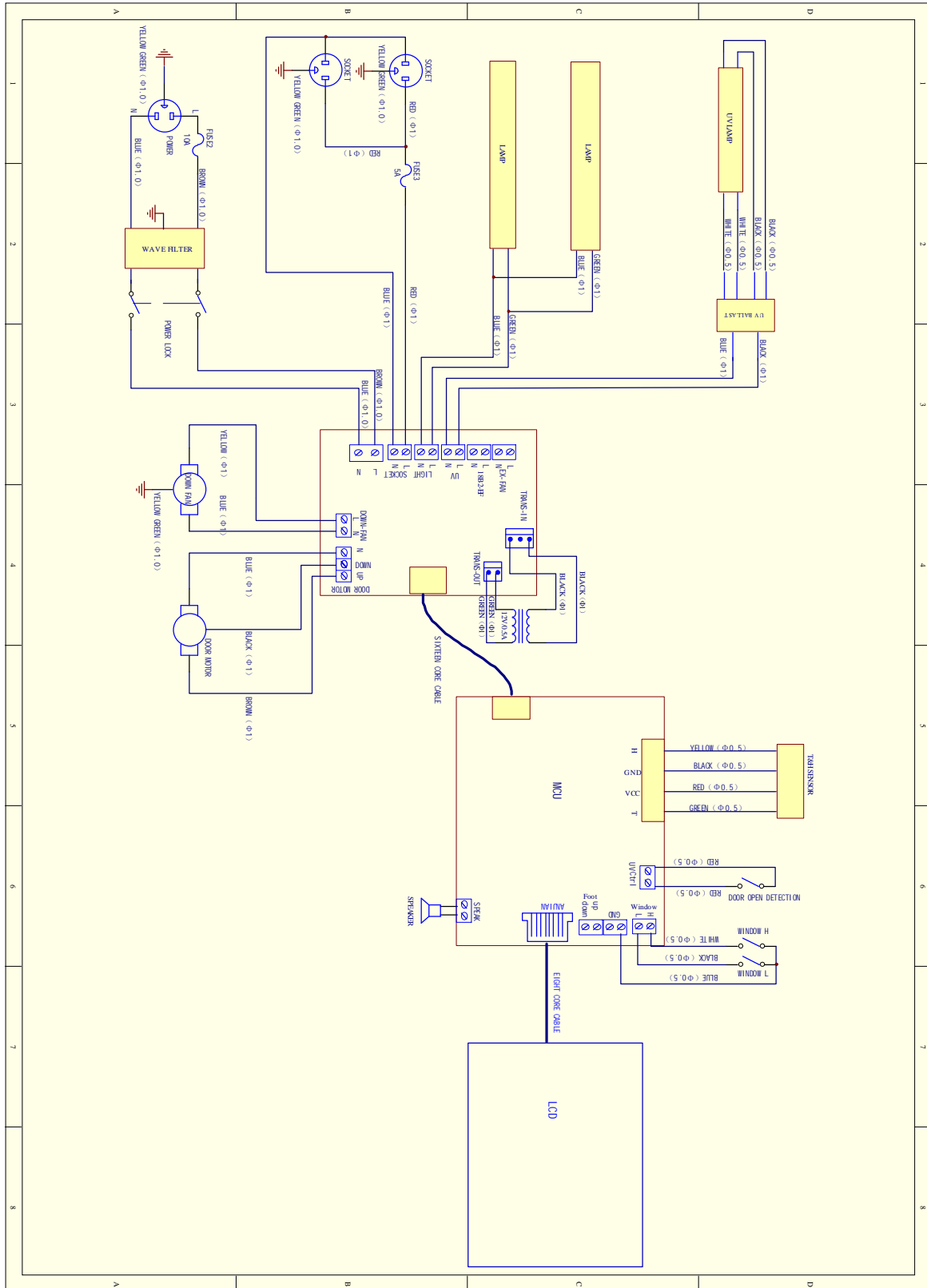

BSC-1500IIA2-X Wiring diagram

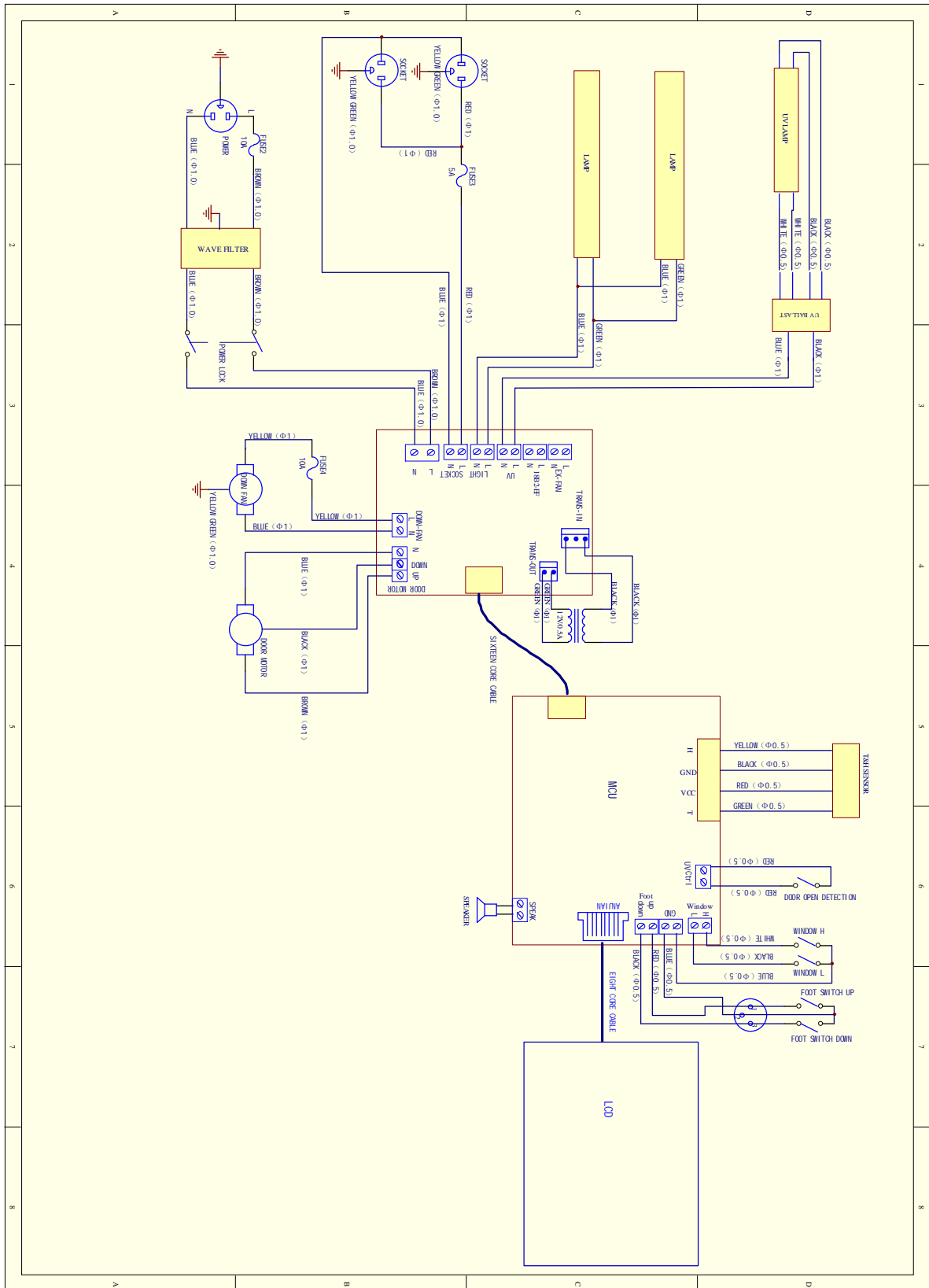

3. Trouble shooting and Labels

3.1 Common faults & solution

3.1.1 Warning and reminder

Digital display of pressure difference, digital velocity display, audible and visual alarm system.

1) Over safety height alarm for front window

There will be audio and visual alarm when front window is lifting over safety height. Same time LCD display will twinkle exclamation mark. Then just adjust the height of the front window.(Front window height setting value is 200mm).

2) ULPA filter pressure difference alarm

There will be audio and visual alarm if pressure of air supply filter or exhaust filter can't meet present value, at the same time LCD display will twinkle exclamation mark. Remind the operator to replace the filter immediately to protect the operator's safety.

3) Velocity fluctuation alarm

There will be audio and visual alarm if the inflow velocity and down flow velocity below 20% of the standard value, namely, inflow velocity below 0.42m/s, down flow velocity below 0.26m/s, at the same time LCD display will twinkle exclamation mark to remind the operator pay attention.

3.1.2 Trouble shooting

Please confirm whether the power is connected or not, whether the power cord is obvious damaged or not, whether the fuse is good or not, and whether the power locks are in the open state or not before the fault diagnosis.

Faults	Check parts	Measures
LED lamp doesn't work	Circuit	Check circuit
	LED tube	Change it
	Control panel	Change it
UV lamp doesn't work	Front window, LED lamp and blower	Check the front window, LED lamp and the blower is open or not.
	Lamp holder	Tube and lamp holder is connected securely.
	Circuit	Check circuit
	UV lamp	Change it
	Micro Switch	Check if Micro Switch is broken
	Control panel	Change it
Button doesn't work	Control panel	Make sure the power connects well and the fuse is well
		Check if the button is broken
		Make sure the connecting wire is connected well

		Change control panel
Blower doesn't work	Front window	Front window is open or not, blower works only when the front window is open
	Micro Switch	Check if Micro Switch is broken or works fine
	Blower	If blower is broken, change it
	Circuit	Check circuit
	Control panel	Change it
No electricity in socket	Socket fuse	Check if socket fuse is broken
	Socket	Check if socket is broken
	Circuit	Check circuit
	Control panel	Change it
Pressure or air speed displayed incorrectly	Gas circuit	Check whether gas circuit has dropped, is
	Control panel	Change it
Front window doesn't work	Circuit	Check circuit
	Motor of front window	Check front window motor
	Transmission part	Check transmission connection and lead rail
	Control panel	change it
Foot switch doesn't work	Circuit	Check circuit
	Control panel	Change it
Remote control doesn't work	Remote control	Check if the Remote control is broken or not,
	Connection cable	Check whether main control panel and display
	Control panel	Change it
No electricity in equipment	Power supply	Check power supply connects well
	Power wire	Check whether power wire has obvious
	Fuse	Check if the fuse is good
	Power key	Check if power key is open, is broken or not
	Transformer	Check whether the transformer works
	Control panel	Change it
Display doesn't work	Connection winding	Connection winding displacement
	Display screen	Display screen
	Control panel	Control panel

No alarm	Micro switch	Check whether the micro switch is good, and it
	Circuit	Check whether connection circuit of micro
	Control panel	Change it



NOTES

- (1) The above electrical parts must be operated by a qualified electrician in safety conditions (cutting off power supply). The other parts are not allowed to remove; otherwise the user should take responsibility by them;
- (2) When failures are not occur, and the operator can't solve, please notify our maintenance department immediately. For your safety, please do not maintain equipment by yourself;
- (3) The maintenance of this equipment is undertaken by trained and recognized technicians;
- (4) If you need to order parts, contact the agent or our technical service department, and please indicate the model and serial number of the cabinet purchased.

3.1.3 Simple accessories replacement

1) Replace the fuse

Socket, fan fuse (only BSC-1500IIA2-X has fan fuse) are located in the top operation panel. When replace them, turn off the power and disconnect plug, use a Phillips screwdriver counterclockwise pressing screwed fuse holder, remove the fuse out and replace a new fuse, and then clockwise pressing screwed fuse holder; FireWire fuse is located in the side of the cabinet operation panel, take out of the fuse holder using a slotted screwdriver and replace with a new fuse, and then press it back.



Picture 20

2) Replace LED light

When replacing lights, make sure that the power is off, open the operation panel like shown in Picture 21, use the control panel support frame (fixed in the inside position of the control panel as shown), then like Picture 22 shown screwing the tube 90°, take the correspondence type of lamp, put it to the lamp holder and screw 90 °to the right position.

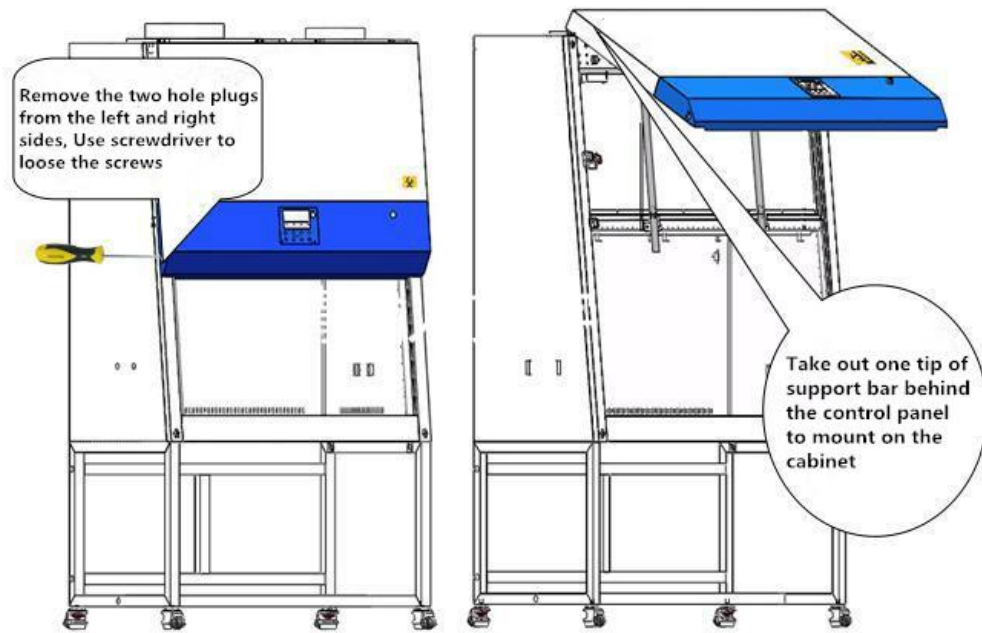

Picture 21

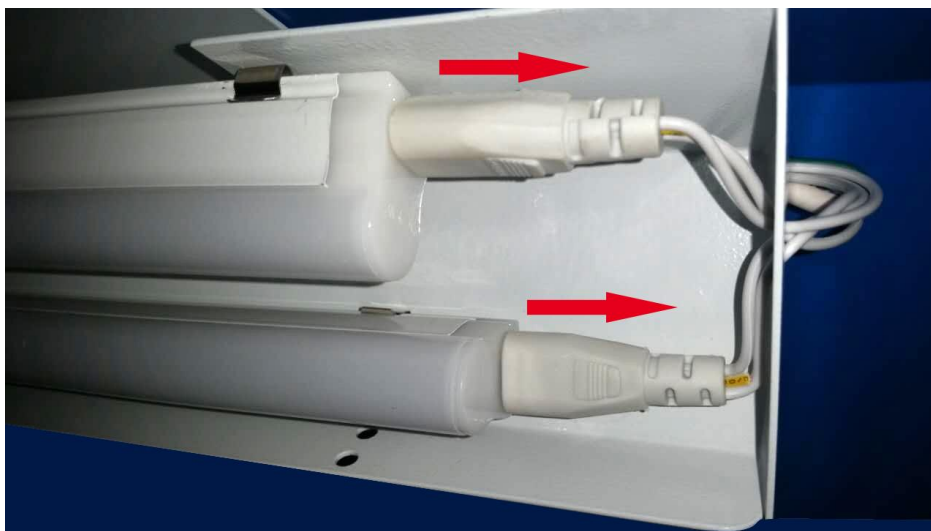

Picture 22

3) Replace the UV lamp

UV lamp should be replaced regularly according to the frequency of use, when using UV lamps reach to the time of 600 hours, we recommend to replace the lamp. When replacing, first make sure the power is off, and then screw the bulb 90 ° and take it off , then take the correspondence type of lamp, and put it to the lamp holder and and screw 90 ° in reverse direction. After replacing the UV lamp, it needs to keep pressing the button of UV for about five seconds when the machine stays standby.



Picture 23

3.2 Label Description

1) Biological hazard label



Picture 24

2) Fuse label

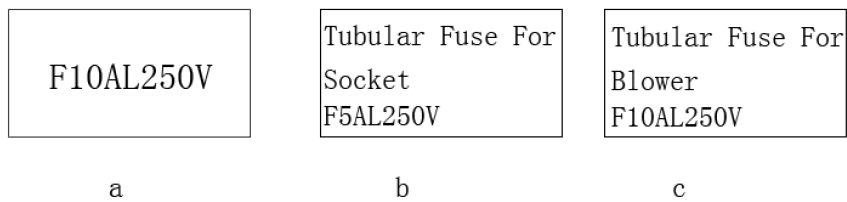

Picture 25

Note:

- a. 10A power fuse label
 - b. Operating area 5A socket fuse labels
 - c. 10A blower fuse label (for BSC-1500IIA2-X)
- 3) Ground label



Picture 26

4)Glass door super elevation warning label



Picture 27

5)UV lamp alarm label



Picture 28

6)Load requirements label

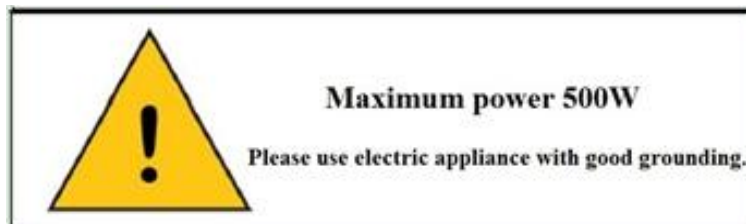

Picture 29

7)Downflow filter upstream label

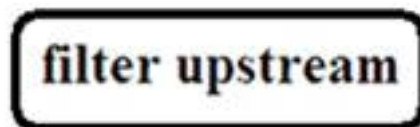

Picture 30

4. Warranty

- 1) Warranty is 1 years from EX-factory date (excluding consumable accessories, UV and LED lamp, fuse).
- 2) We will take no responsibility for risks caused by improper operation and man-made damages.
- 3) After the expiration of warranty, our company is also responsible for repairs, but the corresponding maintenance cost should be charged.
- 4) Life time of biosafety cabinet is 8 years from production date on the label.
- 5) We can provide equipment drawings and necessary technical data for maintenance companies or personnel trained by our company.

Warranty declaration: One-year Warranty, Life-long Maintenance.