Dissolution Tester RC-3

User's Manual

Shanghai Lorderan Scientific Instrument Co., Ltd.

Table of Contents

Table of Contents	1
Introduction.....	2
Product registration.....	2
Technical service	2
Proper operation.....	2
Contact Us.....	2
Introduction.....	3
Brief introduction.....	3
Function description.....	4
Specification	6
Environment requirement	6
Installation.....	6
Unpacking and Checking.....	6
Tester settle	7
Connect to the power supply	7
Pipe line connection.....	7
Bath fluid.....	7
Bath box.....	7
Refill bath liquid.....	7
Cycle liquid.....	7
Empty cycle liquid.....	7
Change cycle liquid	7
Unit conjunction.....	8
Offset adjustment	8
Adjust the depth of the rotating lever.....	8
Adjust the center of the rotating lever	8
Operation	8
Power on.....	8
Preset parameter.....	8
Temperature control	8
Rotation control.....	8
Timing control.....	9
Test.....	9
Sampling.....	9
Power off	9
Demonstration	9
Maintenance	10
Troubleshooting	10
Packing list.....	11
Product quality guarantee	12
Using instruction	12
Registration card	12

Introduction

Thanks for purchasing the product RC-3 Dissolution tester designed and manufactured by us. Please read user's manual carefully before using the product. It will help you operate it properly and efficiently.

Product Registration

Prior to use the product, please fill up the user's registration card and mail to us, in order to get our service in future.

Technical Service

Pls. contact our marketing department for any service during warranty. Be sure that you have sent back the user's registration card.

If you have any problems, Pls. Try to find answers in user's manual first, or you can call our marketing department.

Proper Operation

Make sure you have read this manual carefully before installing/operating the instrument. For any concerns pls. Contact us.

- Transport with care. Any incline, convert, and hit are prohibited.
- Check and protect all safety related labels.
- It is prohibited to use any damaged product and power cord.
- Turn off the power before maintenance, or moving.

Contact Us

Shanghai Lorderan Scientific Instrument Co., Ltd.

Office Address: Room.1508, No. 32, Lane 3128 Middle Chengliu Road, Shanghai

Factory Address: No. 16 Zhangye Road, Fengxian District, Shanghai

Tel/Fax: 021-51268189, 61732073 (P.C 201822)

Email: sales@lorderan.com/

www.lorderan.com/

Introduction

Brief introduction

RC-3 Dissolution tester consist of control system, electric system, water bath system, transmission system, lifting system, transducer unit, paddle unit and rotating basket unit etc. It is mainly controlled by MPU. The features are: reasonable structure, automatic and simplified operation, high accuracy and sensitivity, low noise and errors and stable performance.

The chassis of RC-3 Dissolution tester is composed of pedestal, foot, electric case, control case, front panel and rear panel.

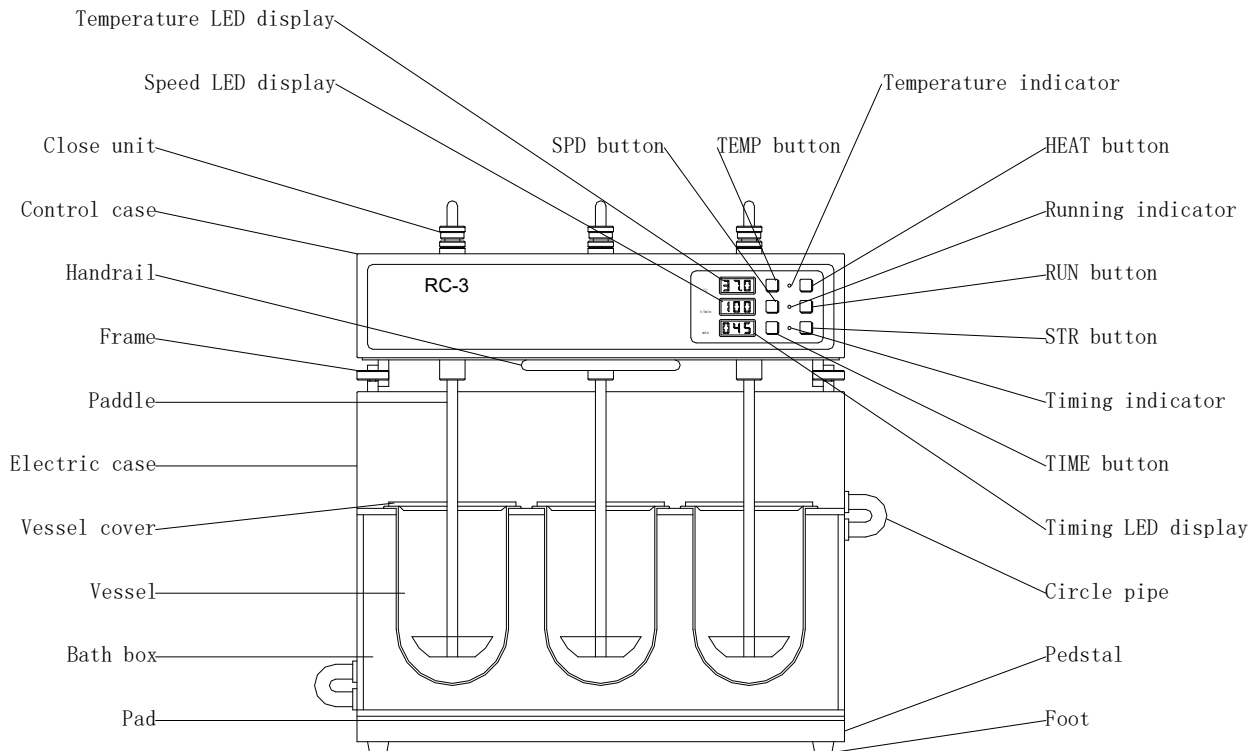

Front panel includes:

- Temperature LCD display
- Temperature indicator
- Temperature button
- Heat button
- Speed LCD display
- Running indicator
- Speed button
- Running control button
- Time LCD display
- Timing indicating
- Timing button
- Start button

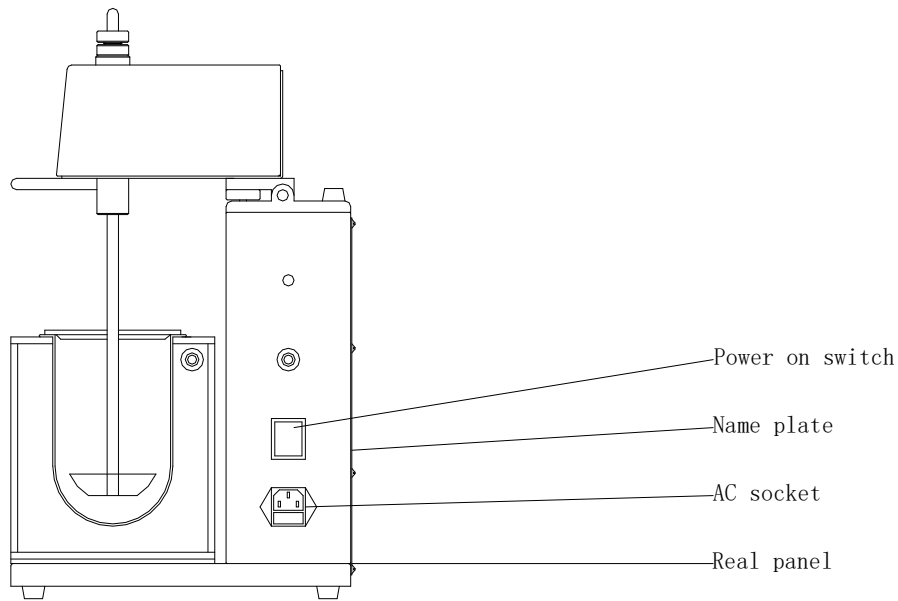

Rear panel includes:

- Power on switch
- AC socket(fuse jack included)
- Name plate

Function description

- Temperature LCD display

Three LCDs in the temperature display area are used to display the preset temperature or the actual temperature. The unit of temperature is centigrade($^{\circ}\text{C}$).

- Temperature indicator

Temperature indicator indicates the working status of the system. When it light, it means the system in automatic controlled status, otherwise, it means the system in uncontrolled status.

- Temperature button

Temperature button is used to setup the temperature. Pressing the button will display the present value (default 37.0°C). Press it again can change the preset temperature. After releasing it about 2 seconds, the temperature display area will display real value.

You can setup the temperature between $\text{RT.}\sim 45.0^{\circ}\text{C}$

Press the button with beep sound.

- Heat button

Heat button has the function of controlling the working state of the temperature system. Pressing the button will turn on or turn off the automatic temperature

system and the LCDs will display the actual temperature value at this time.

The buzzer in the instrument will beep shorter every time when the button is pressed.

- The Speed LCD display

Three LCDs in this area will display the preset speed or the actual rotating speed of the paddle (or the rotating disk). The unit of this parameter is RPM.

- Running indicator

Rotating indicator  indicates the working state of the rotation system. It lightening means that the system controls the rotation speed automatically, on the contrary, the system is in none controlling state.

- Speed button

Speed button is to setup the rotating speed. Pressing the button will display the present value (default 100RPM). Press it again can change the preset speed. After releasing it about 2 seconds, the speed display area will display real value.

You can setup the speed between (20~200)RPM.

Press the button with beep sound.

- Running button

Running button has the function of controlling the rotation of the paddle. Pressing the button will start or stop rotation of the paddle. The LCDs will display the actual rotation speed at this time.

The buzzer in the instrument will beep shorter every time when the button is pressed.

- Time number display

These LCDs is used to display the preset time or the actual surplus time of the rotation. The unit is min.

- Timing indicator

Timing indicator  indicates the working state of the timing system. It lightening means that the system is in the automatic controlling state, on the contrary, the system is in none time state.

- Timing button

Timing button is to setup the time. Pressing the button will display the present value (default 45 MIN). Press it again can change the preset time. Increase 1MIN per pressing button between 1 MIN and 30 MIN. Increase 5 MIN per pressing button between 30 MIN and 900 MIN.

You can setup the time between (5~900) MIN.

Press the button with beep sound.

- Start button

Start button has the function of controlling the time. Pressing the button will turn on or turn off the automatic timing system. The LCDs will display the actual surplus time at this moment.

The buzzer in the instrument will beep shorter every time when the button is pressed.

● Power switch

Power on switch is the main power switch. In ON position, tester is in working status, inversely, tester stop working.

Before connecting to AC power, please ensure it's in OFF position!

● AC socket

AC socket is connected to the power supply with power cord offered in this tester.

Fuse is under the AC socket. Attached one 3A fuse and a backup one is offered. This is to prevent damage to this tester in suddenness case.

Please make sure AC power supply is connected properly!

When change fuse, make sure same spec part is used for tester safety!

Specification

Model	RC-3
Testing Station	3
Speed Range	20~200 rpm
Speed Accuracy	±2 rpm
Temperature Range	Rt~45.0°C
Temperature Stability	±0.3°C
Preset Timing Nine Points	5~900 min
Time Accuracy	±0.5 mm
Paddle Radial Run-Out	±0.5 mm
Basket Radial Run-Out	±1.0 mm
Power Supply	220V/ 50 Hz, 110V/ 60 Hz
Power	600 W
Dimension	510×300×480 mm
Weight	25 kg

Environment requirement

Usage temperature	+18°C~+28 °C
Store temperature	-10°C~+50 °C
Humidity	20%~80% RH

Installation

Unpacking and Checking

Open package, take out manual, tester, and accessories, and check items according to packing

list. Any mismatch/damage happened, please contact marketing department immediately.

Tester settle

Tester must be placed on stable work station/table and put damping pad between bath box and tester.

Minimum space required around test is 0.5m, to ensure heat escaping. Clean tester periodically to prevent tester from abnormal operation.

Connect to the power supply

Link the socket & AC power supply source with attached power cord.

Pipe line connection

Connect the bath box and the electric box with attached plastic pipe. The entrance of the bath box is connected to the exit of the electric box, while the exit of the bath box is connected to the entrance of the electric box.

Soak the pipe in hot water to soft it before connecting the pipe.

Bath fluid

Suggest using distillation water.

Bath box

Constant temperature bath system is composed of bath box, heater and cycle water pump. It used to supply high efficient bath. Recommend to use distilled water. Normally, 30 min. can reach the setting temperature.

Never run bath box without water!

Refill cycle liquid

Clean up the bath box and pour into the cycle liquid until it come to the calibration.

Cycle liquid

Gas inside the bath circulation system must be emptied before normally using the instrument, to ensure the effective circulation of the bath liquid.

Put the aspirator into the water inlet of the bath. Turn on power, the power indicator light and pump run. Empty the gas of the system until the liquid pump smoothly.

It is strictly prohibited to revolve the pump in empty conditions.

Empty cycle liquid

Empty the water with aspirator and pipe. Clean up the bath box.

Change cycle liquid

Chang cycle liquid can be completed by repetitively operate the empty, fill and cycle procedures.

Unit conjunctive

● Paddle conjunctive

The drive head is turn up. Put the paddle in the hole of axle, up it on top, set close unit in head of paddle and close. The drive head is turn down.

● Basket conjunctive

The drive head is turn up. Put the basket shaft in the hole of axle, up it on top, set close unit in head of basket shaft and close. The drive head is turn down.

Put the specimen in the basket. Set it up underneath of basket shaft.

● Put vessels in hold of bath box and press it with the button.

Offset adjustment

Adjust the depth of the rotating lever

The interval between the underneath of blade and the bottom of the vessel is measured with the depth gage. Adjust the suit of the close unit on the rotating lever, make the range interval with 25 MM.

Adjust the center of the rotating lever

Move the vessel to adjust the exact centering of the vessel in relation to each shaft.

Operation

Power on

Turn the power switch to ON position, the indicator light, initialize the tester for 10 minutes, then it's readiness.

Preset parameter

When power turns on, the system is first in the presetting state and the default parameters are as follows: temperature 37.0°C, speed 100RPM, time 045MIN.

Press TEMP button to preset temperature.

Press SPD button to preset the speed of rotate.

Press TIME button to preset the time.

Temperature control

The system returns real state in 2 seconds after parameters were preset. Pressing button HEAT will turn on the automatic temperature system. Repeat pressing button to turn off it.

Rotation control

The system returns real state in 2 seconds after parameters were preset. Pressing button

RUN will rotate the shaft. Repeat pressing button to stop it.

Timing control

The system returns real state in 2 seconds after parameters were preset. Pressing button STR will turn on the automatic time system. Repeat pressing button to turn off it.

Test

Choose basket or paddle based on the specimen's name and test method. Turn on power, preset parameters. Fetch quantum solvent without gas, put it in each vessel. The solvent's temperature is stabilized with preset temperature. Sample three specimens, put them in three baskets or vessels separately. Down baskets or paddles in vessels, turn on rotating and timing. Sample quantum solvent after timing end and filter it with 0.8u filtration film. Fetch and test it. Each specimen's dissolution is figured out.

Sampling

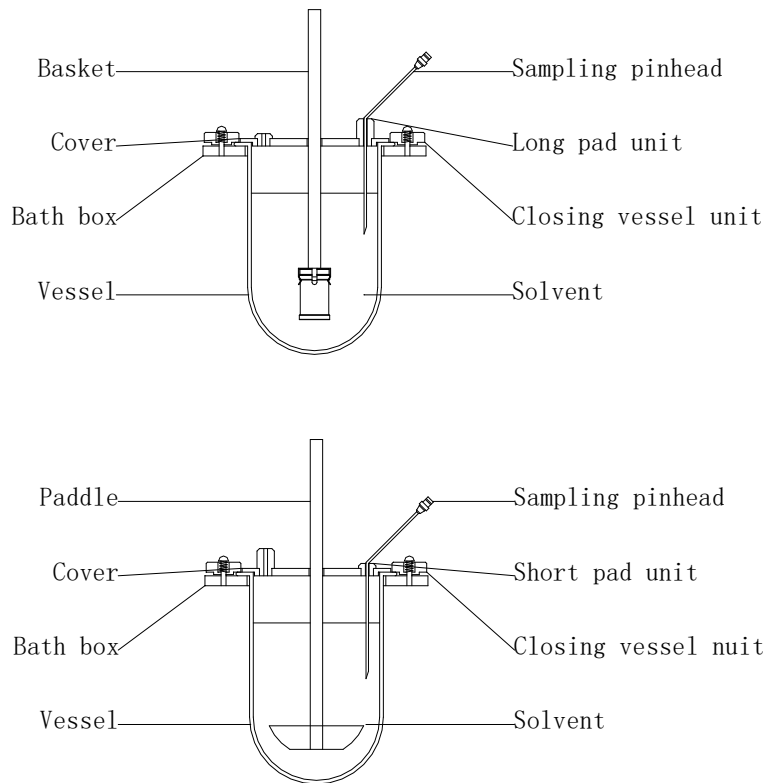

Power off

Turn switch to OFF position, the indicator is off and tester stop working.

Demonstration

- (1) Power on.
- (2) Preset parameter.
- (3) Return real state.

- (4) Put in solvent.
- (5) Controlling temperature.
- (6) Put specimen in.
- (7) Controlling rotating.
- (8) Controlling time.
- (9) Timing end, sample, filter, test.
- (10) Same measurement can be completed by carry out (2)~(9) repetitively.

Maintenance

Clean box and parts periodically. Do not use steel brush, it will result in damage to the tester.

Troubleshooting

- Can not power on

Check whether the voltage is OK and fuse is OK, please refer to the rating marked in nameplate while installation.

- Water dose not loop

Check the pump and it's wire is OK.

- Water's temperature dose not raise

Check the heater and it's wire is OK.

- Water's temperature dose not constant

Check the sensor and it's wire is OK.

- Rotating units don't rotate

Check the motor and it's wire is OK.

If the tester does not work after checking above items, please don't repair it by yourself, contact our market department please.

Packing list

The RC-3 Dissolution tester include following items typically:

- Tester1
- Bath box1
- Vessels3
- Water box pad1
- Attachment box1
 - Vessel Covers3
 - Paddle unit3
 - Rotating basket unit3
 - Locking unit3
- Power cord1
- Deep ruler1
- Center ruler1
- Filter head3
- Filter membrane1
- Sample needle3
- Plastic pipe2
- Soft pipe1
- User's manual1

Product quality guarantee

- This quality guarantee covers the scope of RC-3 Dissolution tester.
- Start from purchasing date; warranty period is one year.
- This quality guarantee is effective from receiving registration card filled by users.
- During warranty, we offer free charge service for troubleshooting in normal cases, but for any cases caused by flood, fire, earthquake, or other calamity, is excepted.
- During warranty, in one of the following cases, we will charge for material/service:
- No product quality guarantee, mismatch with this guaranty or wrong record/remark.
- Damages caused by unusual working environment.
- Damages caused by disassembly, install, extend, move or modify without our permission.
- Damages caused by repairing without our permission.
- Keep this guarantee in proper place and any other issue is provided.

Using Instruction

- Proper operation & maintenance will prolong the working time of the instrument. Please follow the manual's instruction carefully.
- When the power supply is unstable, pls. Use AV regulator. Pay special attentions to the information related to power supply, temperature, humidity in the manual.
- Always keep the instrument cleaning. Disassembly/move any parts of the tester is prohibited.
- In case of trouble present, pls. Stop using, call us or dealer for help.

Registration card

Name	
Address	
ZIP	E-mail
Tel	Fax
Product	
Model	S/N