Tablet Four-usage Tester PJ-6D

User's Manual

Shanghai Lorderan Scientific Instrument Co., Ltd.

Table of Contents

Table of Contents	1
Introduction.....	3
Product registration.....	3
Technical service	3
Proper operation.....	3
Contact Us.....	3
Introduction.....	4
Brief introduction.....	4
Function description.....	5
Specification	8
Environment requirement	8
Power supply.....	8
Installation.....	9
Unpacking and Checking.....	9
Tester settle	9
Connect to the power supply	9
Pipe line connection.....	9
Bath fluid.....	9
Bath box.....	9
Refill bath liquid.....	9
Cycle liquid.....	9
Empty cycle liquid.....	9
Change cycle liquid	10
Unit conjunction.....	10
Adjust the depth of the rotating lever.....	10
Adjust the center of the rotating lever	10
Hardness correction	10
Operation	11
Power on.....	11
Preset parameter.....	11
Temperature control	11
Rotation control.....	11
Timing control.....	11
Dissolution test.....	11
Dissolution sampling.....	11
Disintegration test	12
Friability test	12
Hardness test	12
Power off	12
Demonstration	12
Dissolution	12
Disintegration.....	13
Friability.....	13
Hardness.....	13
Maintenance	13
Troubleshooting	13
Packing list.....	15

Product quality guarantee	16
Using instruction	16
Registration card	16

Introduction

Thanks for purchasing the product PJ-6D Tablet four-usage tester designed and manufactured by us.

Please read user's manual carefully before using the product. It will help you operate it properly and efficiently.

Product Registration

Prior to use the product, please fill up the user's registration card and mail to us, in order to get our service in future.

Technical Service

Pls. contact our marketing department for any service during warranty. Be sure that you have sent back the user's registration card.

If you have any problems, Pls. Try to find answers in user's manual first, or you can call our marketing department.

Proper Operation

Make sure you have read this manual carefully before installing/operating the instrument. For any concerns pls. Contact us.

- Transport with care. Any incline, convert, and hit are prohibited.
- Check and protect all safety related labels.
- It is prohibited to use any damaged product and power cord.
- Turn off the power before maintenance, or moving.

Contact Us

Shanghai Lorderan Scientific Instrument Co., Ltd

Office: Room.1508, No. 32, Lane 3128 Middle Chengliu Road, Shanghai

Factory Add: NO.16 Zhangye Road, Fengxian District, Shanghai

Tel: 86-21-511268189, 61732073 Fax: 86-21-61732073 (P.C 201822)

[http: //www.lorderan.com/](http://www.lorderan.com/)

Introduction

Brief introduction

PJ-6D Tablet four-usage tester consists of main box, control system, electric system, water bath system, transmission system, transducer unit, paddle unit and rotating basket unit etc. As it is mainly controlled by MPU, the PJ-3 can be operated easily and automatically. It also has a high performance in accuracy and sensitivity.

The main box is composed of pedestal, foot, electric case, control case, front panel and rear panel.

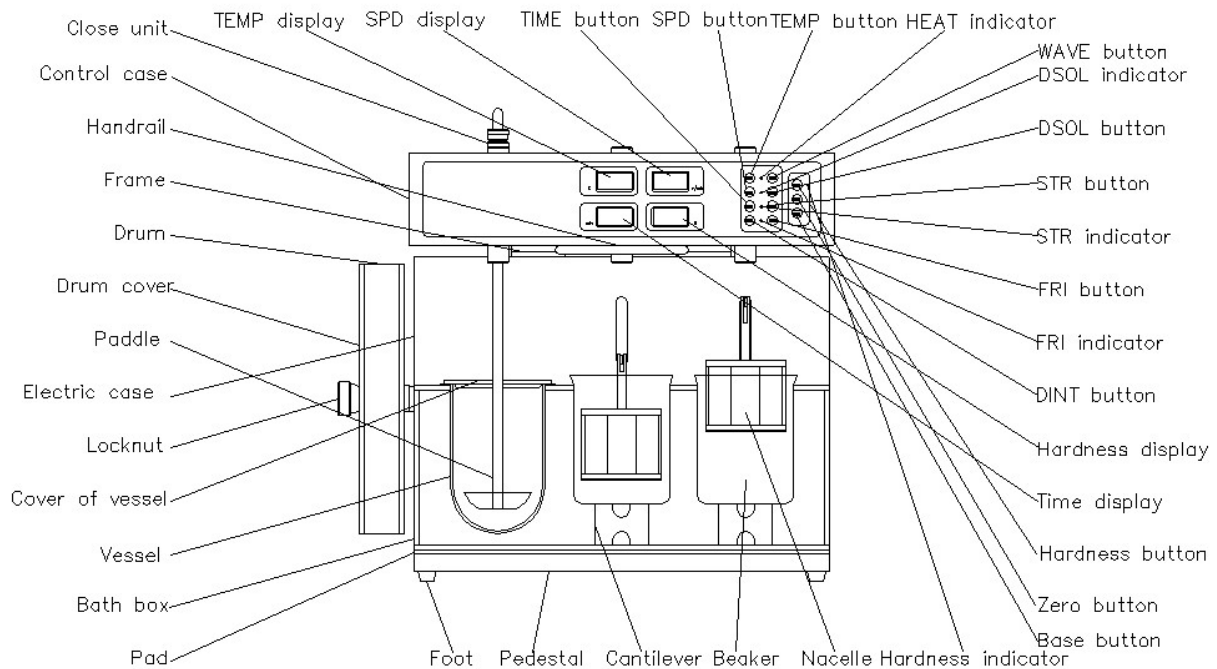

Front panel includes:

- Temperature LCD display
- Speed LCD display
- Time LCD display
- Hardness LCD display
- Temperature button
- Speed button
- Timing button
- Heating control indicator
- Dissolution indicator
- Timing indicator
- Friability indicator
- Heat button
- Dissolution button
- Timing start button
- Friability button
- Disintegration button
- Hardness
- Hardness button
- Zero button

- Base button

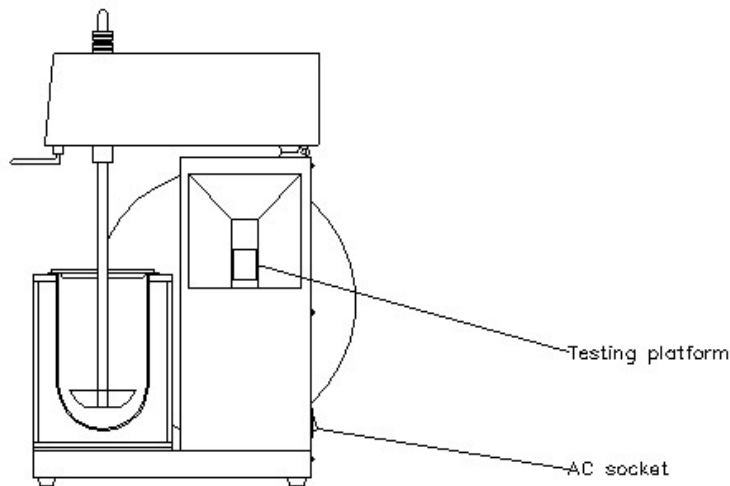

Rear panel includes:

- Power on switch
- AC socket(fuse jack included)

Function description

- Temperature LCD display

Three LCD in the temperature display area are used to display the preset temperature or the actual temperature. The unit of temperature is centigrade ($^{\circ}\text{C}$).

- The Speed LCD display

Three LCD in this area will display the preset speed of dissolution or the actual rotating speed of dissolution, disintegration or friability. The unit of this parameter is r/min.

- Time number display

Three LCD is used to display the preset time or the actual surplus time of the rotation. The unit is min.

- Hardness LCD display

Three digital LCD display hardness value of test, unit is N.

- Temperature button

Temperature button is used to setup the temperature. Pressing the button will display the present value (default 37.0°C). Press it again can change the preset temperature. After releasing it about 2 seconds, the temperature display area will display real value.

You can setup the temperature between RT.~ 45.0°C .

Press the button with beep sound.

- Speed button

Speed button is to setup the rotating speed. Pressing the button will display the present value (default 100r/min). Press it again can change the preset speed. After releasing it about 2 seconds, the speed display area will display real value.

You can setup the speed between (20~200) r/min.

Press the button with beep sound.

- Timing button

Timing button is to setup the time. Pressing the button will display the present value (default 45min). Press it again can change the preset time. Increase 1min per pressing button between 1min and 30min. Increase 5min per pressing button between 30min and 900min.

After releasing it about 2 seconds, the speed display area will display real surplus value.

You can setup the time between (5~900) min.

Press the button with beep sound.

- Heating control indicator

Heating control indicator indicates the working status of the system. When it light, it means the system in automatic controlled status, otherwise, it means the system in uncontrolled status.

- Dissolution indicator

Dissolution indicator © indicates the working state of the dissolution system. It lightening means that the system controls the rotation speed of dissolution automatically, on the contrary, the system is in none controlling state.

- Timing indicator

Timing indicator © indicates the working state of the timing system. It lightening means that the system is in the automatic controlling state, on the contrary, the system is in none time state.

- Friability indicator

Friability indicator © indicates the working state of the friability system. It lightening means that the system controls the rotation speed of friability's drum automatically, on the contrary, the system is in none controlling state.

- Wave button

Heat button has the function of controlling the working state of the temperature system. Pressing the button will turn on or turn off the automatic temperature system and the LCD will display the actual temperature value at this time.

The buzzer in the instrument will beep shorter every time when the button is pressed.

- Dissolution button

Dissolution button has the function of controlling the rotation of the paddle. Pressing the button will start or stop rotation of the paddle. The LCD will display the actual rotation speed at this time.

One of dissolution, Friability and disintegration is working.

The buzzer in the instrument will beep shorter every time when the button is pressed.

- Timing start button

Timing start button has the function of controlling the time. Pressing the button will turn on or turn off the automatic timing system. The LCD will display the actual surplus time at this moment.

The buzzer in the instrument will beep shorter every time when the button is pressed.

- Friability button

Friability button has the function of controlling the rotation of the drum. Pressing the button will start or stop rotation of the drum. The LCD will display the actual rotation speed at this time.

One of dissolution, Friability and disintegration is working.

The buzzer in the instrument will beep shorter every time when the button is pressed.

- Disintegration button

Disintegration button has the function of controlling the running of the nacelles. Pressing the button will start or stop running of the disintegration's nacelles. The LCD will display the actual running speed at this time.

One of dissolution, Friability and disintegration is working.

The buzzer in the instrument will beep shorter every time when the button is pressed.

- Hardness button

Hardness button is used to control system's work status. Press the button first, system start to test.

- Hardness indicator

Hardness lamp indicates system's work mode. When it's on, indicates system is on test mode, or system is on stop mode.

- Zero button

Zero function keys, the instrument did not test, if appear hardness value display is not zero. Press this button, the screen, display for 0000.

- Base button

Benchmark function keys. To benchmark parameters calibration for instrument.

- Power switch

Power on switch is the main power switch. In ON position, tester is in working status, inversely, tester stop working.

Before connecting to AC power, please ensure it's in OFF position!

- AC socket

AC socket is connected to the power supply with power cord offered in this tester.

Fuse is under the AC socket. Attached one 3A fuse and a backup one is offered. This is to prevent damage to this tester in suddenness case.

Please make sure AC power supply is connected properly!

When change fuse, make sure same spec part is used for tester safety!

Specification

Model	PJ-6D
Testing Parameter	Hardness, Friability, Disintegration, Dissolution
Temperature Range	RT.~45 °C, ±0.3 °C
Speed Range	20~200 rpm ±2 rpm
Timing Range	5~900 min ±0.5 min
Paddle Radial Run-Out	±0.5 mm
Basket Radial Run-Out	±1.0 mm
Centering	±2.0 mm
Dissolution Station	6
Nacelles	2
Nacelle Glass Tubes	6
Volume Of The Beaker	1000 ml
Nacelle Up And Down Frequency	30~32/min
Nacelle Up And Down Range	55±1 mm
Drum	1
Drum's Radius	Dia. 286 mm
Drum's Depth	39 mm
Tablet Falling Height	156 mm
Rotation Count	100 r
Rotation Speed	25 rpm
Speed Regulator Accuracy	±1 rpm
Hardness Range	2~199.9N (50Kg, 499.9N is optional)
Probe Procession Range	3~40 mm
Power Supply	220V/ 50 Hz, 110V/ 60 Hz
Power of The Heater	600 W
Dimension	580×480×470 mm
Weight	42 Kg

Environment requirement

Usage temperature	+18°C~+28 °C
Store temperature	-10°C~+50 °C
Humidity	20%~80% RH

Installation

Unpacking and Checking

Open the package, take out manual, tester, and accessories. And check items according packing list. Any mismatch/damage happened, please contact marketing department immediately.

Tester settle

Tester must be placed on stable work station/table and put damping pad between bath box and tester.

Minimum space required around test is 0.5 m, to ensure heat escaping. Clean tester periodically to prevent tester from abnormal operation.

Connect to the power supply

Link the socket & AC power supply source with attached power cord.

Pipe line connection

Connect the bath box and the electric box with attached plastic pipe. The entrance of the bath box is connected to the exit of the electric box, while the exit of the bath box is connected to the entrance of the electric box.

Soak the pipe in hot water to soft it before connecting the pipe.

Bath fluid

Suggest using distillation water.

Bath box

Constant temperature bath system is composed of bath box, heater and cycle water pump. It used to supply high efficient bath. Recommend to use distilled water. Normally, 30 min. can reach the setting temperature.

Never run bath box without water!

Refill cycle liquid

Clean up the bath box and pour into the cycle liquid until it come to the calibration.

Cycle liquid

Gas inside the bath circulation system must be emptied before normally using the instrument, to ensure the effective circulation of the bath liquid.

Put the aspirator into the water inlet of the bath. Turn on power, the power indicator light and pump run. Empty the gas of the system until the liquid pump smoothly.

It is strictly prohibited to revolve the pump in empty conditions.

Empty cycle liquid

Empty the water with aspirator and pipe. Clean up the bath box.

Change cycle liquid

Change cycle liquid can be completed by repetitively operate the empty, fill and cycle procedures.

Unit conjunctive

● Paddle conjunctive

The drive head is turn up. Put the paddle in the hole of axle, up it on top, set close unit in head of paddle and close. The drive head is turn down.

● Basket conjunctive

The drive head is turn up. Put the basket shaft in the hole of axle, up it on top, set close unit in head of basket shaft and close. The drive head is turn down.

Put the specimen in the basket. Set it up underneath of basket shaft.

- Put vessels in hold of bath box and press it with the button.
- Put cantilevers in bath box and put beakers on them.

Adjust the depth of the rotating lever

The interval between the underneath of blade and the bottom of the vessel is measured with the depth gage. Adjust the suit of the close unit on the rotating lever, make the range interval with 25 mm.

Adjust the center of the rotating lever

Move the vessel to adjust the exact centering of the vessel in relation to each shaft.

Hardness Correction

- ① The user shall install Weight Hook on the Correction Lever on the left side of the instrument.
- ② Hold the instrument by hand and set it vertically, so that the left side is placed down on a flat soft table and Weight Hook is exposed outside the table.
- ③ Start up, press the Debugging Status Key, and make the instrument enter the debugging status; press the Zero Setting Key and set the hardness value to be 000.0N (00.00KG).
- ④ Hang 5KG standard weight on Weight Hook, and the hardness value should be 049.0N ($\pm 0.5N$). Be careful to operate it and do not collide it with force.
- ⑤ If the displayed value is incorrect, press Calibration Function Key, and set the hardness value to 049.0N ($\pm 0.5N$)
- ⑥ Remove 5KG standard weight, press the Zero Setting Key, and set the hardness value to 000.0N.
- ⑦ Repeat steps ⑤~⑥ until the value reaches 000.0N in unloading and reaches 049.0N in loading.
- ⑧ Place the instrument on the table horizontally, press Debugging Status Key, and exit the debugging status until the hardness correction is completed.

PS: After the calibration, if the display is “--- N”, press Debugging Status Key AGAIN, and press Zero Setting Key, then press Debugging Status Key.

Operation

Power on

Turn the power switch to ON position, the indicator light, initialize the tester for 10 minutes, then it's readiness.

Preset parameter

When power turns on, the system is first in the presetting state and the default parameters are as follows: temperature 37.0 °C, speed 100 r/min, time 045 min.

Press TEMP button to preset temperature.

Press SPD button to preset the speed of rotate.

Press TIME button to preset the time.

Temperature control

The system returns real state in 2 seconds after parameters were preset. Pressing button HEAT will turn on the automatic temperature system. Repeat pressing button to turn off it.

Timing control

The system returns real state in 2 seconds after parameters were preset. Pressing button STR will turn on the automatic time system. Repeat pressing button to turn off it.

Dissolution test

Turn off timing system, disintegration testing and friability testing. Pick up nacelles and put vessels in bath box. Choose basket or paddle based on the specimen's name and test method. Turn on power, preset parameters. Fetch quantum solvent without gas, put it in each vessel. The solvent's temperature is stabilized with preset temperature. Sample three specimens, put them in three baskets or vessels separately. Down baskets or paddles in vessels, turn on rotating and timing. Sample quantum solvent after timing end and filter it with 0.8 um filtration film. Fetch and test it. Each specimen's dissolution is figured out.

Dissolution sampling

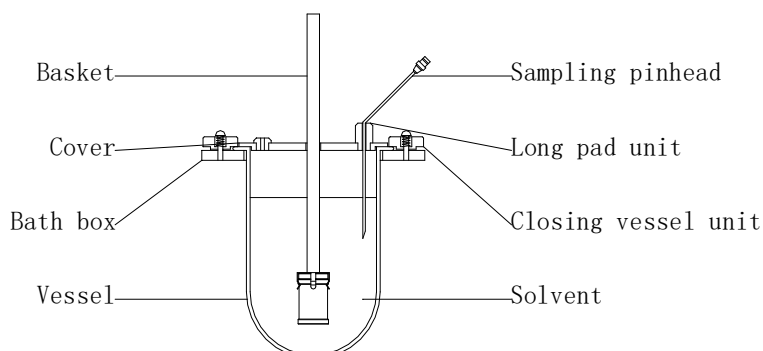

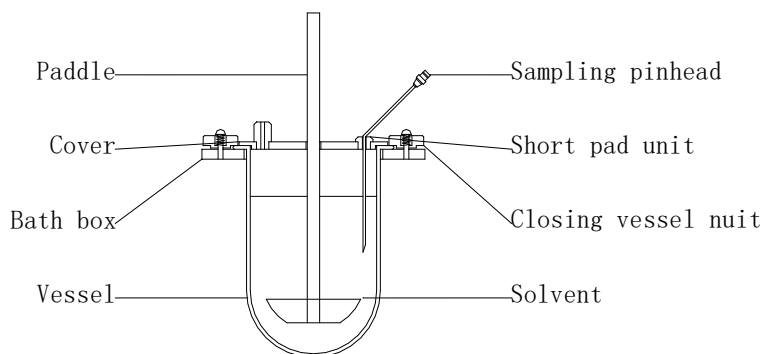

Disintegration test

Turn off timing system, dissolution testing and friability testing. Pick up paddles (or basket) and put beakers in bath box. Put the 6 samples into the 6 tubes of the nacelle and hang onto the hook. Press DINT button, nacelle is moving back and forth to test, press STR immediately. When the time is over, read the measurements about the samples.

Friability test

Turn off timing system, dissolution testing and disintegration testing. Put the rotation part off and open the cover, put in 6.5 g sample material and close the cover, put it onto the level axis and lock the bolts. Press FRI and STR button, the test process is begins. When the time is over, the rotation part stops to measure the sample's friability.

Hardness test

After startup, hardness LCD display window if not for 000, need to press cut zero to screen out. Place the pills being tested on the test bench, located between the probe and test bed; Press the key, hardness test bed automatically slow moving to the left, to the measured tablets on extrusion, the hardness of the LCD panel display window display numerical increased gradually; When measured tablets by extrusion, LCD display window display numerical hardness and locked by the system, the largest instrument internal buzzer began ringing interrupted, the hardness of the LCD display window display values for the tested tablet hardness value; After about 5 seconds, the instrument internal buzzer ringing stop interrupting, after being test bed to go back to the initial position automatically, then you can start to test next time.

Power off

Turn switch to OFF position, the indicator is off and tester stop working.

Demonstration

Dissolution

- ① Preset parameter.
- ② Return real state.
- ③ Put in solvent.

- ④ Controlling temperature.
- ⑤ Put specimen in.
- ⑥ Controlling rotating.
- ⑦ Controlling time.
- ⑧ Timing end, sample, filter, test.
- ⑨ Same measurement can be completed by carry out ②~⑨ repetitively.

Disintegration

- ① Set time.
- ② Press the temperature button.
- ③ Place the sample into tube of the nacelle and hang the nacelle onto the hook.
- ④ Press DINT and STR button, the nacelle move back and forth to begin testing.
- ⑤ The nacelle stop moving till the preset time. Read the measurement of the sample.
- ⑥ Same measurement can be completed by carry out 3-7 repetitively.

Friability

- ① Set time.
- ② Put the rotation part off and open the cover, put in sample material and close the cover, put it onto the level axis and lock the bolts.
- ③ Press FRI and STR button, the test is begin.
- ④ The rotation part stop moving till the preset time, measure sample's friability.
- ⑤ Same measurements can be completed by carry out 2-4 steps repeatedly.

Hardness

- ① Power on and preheat the tester.
- ② Place the tablet on the test plate, begin test.
- ③ Read the hardness.
- ④ Same with above portion repeat 2-4 steps.

Maintenance

Clean box and parts periodically. Do not use steel brush, it will result in damage to the tester.

Troubleshooting

- Can not power on

Check whether the voltage is OK and fuse is OK, please refer to the rating marked in nameplate while installation.

- Water dose not loop

Check the pump and it's wire is OK.

- Water's temperature dose not raise

Check the heater and it's wire is OK.

- Water's temperature dose not constant

Check the sensor and it's wire is OK.

- Rotating units don't rotate

Check the motor and it's wire is OK.

- Temperature LCD display shows 88.8 and alarm

Check the sensor and it's wire is OK. Check temperature of bath box is exceed 48.0°C or below 0°C.

If the tester does not work after checking above items, please don't repair it by yourself, contact our market department please.

Packing list

The PJ-6D Tablet four-usage tester include following items typically:

- Tester1
- Bath box1
- Vessels6
- Water box pad1
- Attachment box1
 - Vessel Covers6
 - Paddle unit6
 - Rotating basket unit6
 - Locking unit6
 - Power cord1
 - Deep ruler1
 - Center ruler1
 - Filter head6
 - Filter membrane1
 - Sample needle6
 - Plastic pipe2
 - Soft pipe1
 - User’s manual1
 - Product quality guarantee1
 - User’s registration card1
- Rotation accessories1
- Brush1
- Nacelle unit2
- Discs12
- Beaker2
- Aspirator1

Product quality guarantee

- This quality guarantee covers the scope of PJ-6D Tablet four-usage tester.
- Start from purchasing date; warranty period is one year.
- This quality guarantee is effective from receiving registration card filled by users.
- During warranty, we offer free charge service for troubleshooting under normal operation, but for any cases caused by flood, fire, earthquake, or other calamity, is excepted.
- During warranty, under the one of the following cases, we will consider to charge material/service fee to users:
 - No product quality guarantee, mismatch with this guaranty or wrong record/remark.
 - Not follow the using environment required in users manual.
 - Disassembly, install, extend, move or modify this tester without our permission.
 - Unqualified technician repairing without permission.
 - Keep this guarantee in proper place and no reissue is promised.
 - The guarantee is only applicable in Chinese mainland.

Using instruction

- Proper operation & maintenance will ensure instrument usage life, please follow users manual's instruction.
- When the power supply is unstable, pls. Use AV regulator, and special notice the information related to power supply, temperature, humidity in the manual.
- Always keep instrument clean. Disassembly/move any parts of this tester is prohibited.
- In case of trouble found, pls. Stop using, inform dealer or company with model, S/N, and phenomenon.

Registration card

Name	
Address	
ZIP	E-mail
Tel	Fax
Product	
Model	S/N