

Tablet Dual-usage Tester PJ-2D

User's Manual

Shanghai Lorderan Scientific Instrument Co., Ltd.

Introduction

Thanks for purchasing the product PJ-2D Tablet dual-usage tester designed and manufactured by us.

Please read user's manual carefully before using the product. It will help you operate it properly and efficiently.

Product Registration

Prior to use the product, please fill up the user's registration card and mail to us, in order to get our service in future.

Technical Service

Pls. contact our marketing department for any service during warranty. Be sure that you have sent back the user's registration card.

If you have any problems, Pls. Try to find answers in user's manual first, or you can call our marketing department.

Proper Operation

Make sure you have read this manual carefully before installing/operating the instrument. For any concerns pls. Contact us.

- Transport with care. Any incline, convert, and hit are prohibited.
- Check and protect all safety related labels.
- It is prohibited to use any damaged product and power cord.
- Turn off the power before maintenance, or moving.

Contact Us

Shanghai Lorderan Scientific Instrument Co., Ltd

Office: Room.1508, No. 32, Lane 3128 Middle Chengliu Road, Shanghai, China

Factory Add: No.16 Zhangye Road, Fengxian District, Shanghai, China

Tel: 86-21-51268189, 61732073, Fax: 86-21-61732073 (P.C 201822)

<http://www.lorderan.com/>

Introduction

Brief introduction

PJ-2D Tablet dual-usage tester consists of main box, control system, electric system, water bath system, transmission system, transducer unit, paddle unit and rotating basket unit etc. As it is mainly controlled by MPU, the PJ-2D can be operated easily and automatically. It also has a high performance in accuracy and sensitivity.

The main box is composed of pedestal, foot, electric case, control case, front panel and rear panel.

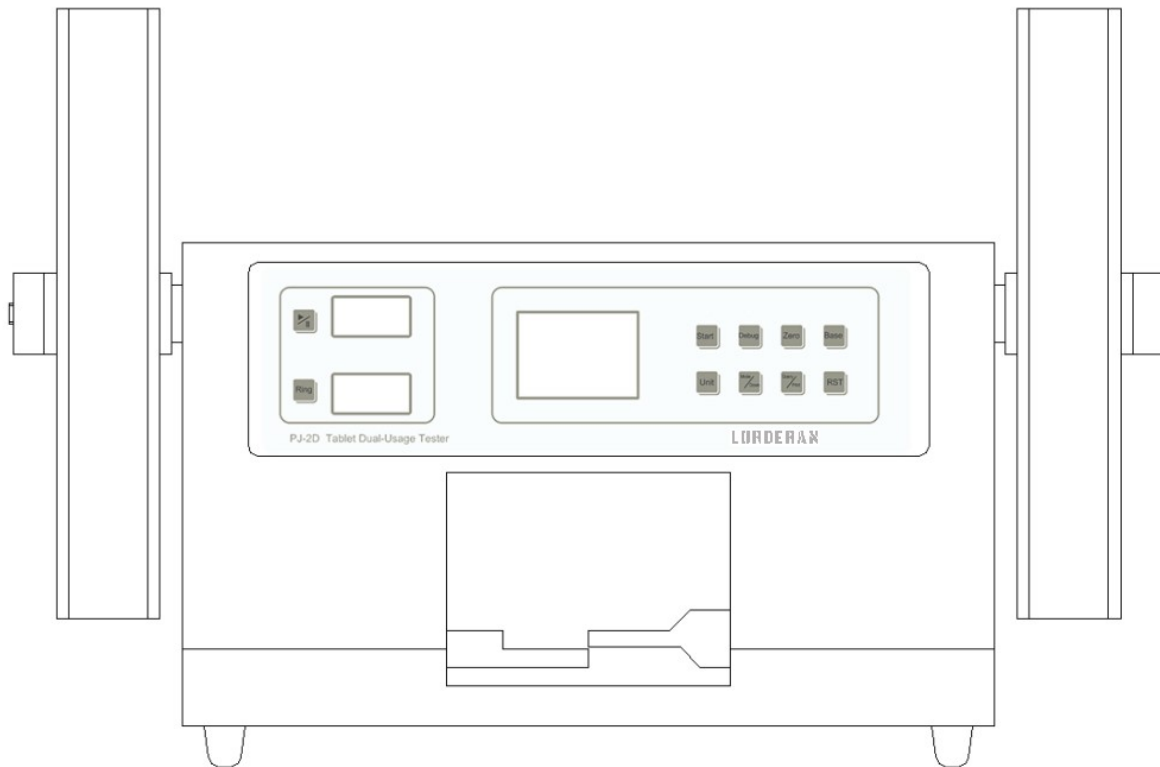

Front panel includes:

- Revolution number display
- Rotate speed number display
- Revolution button
- Unit Conversion Key
- Tablet Number / Page-turning Control Key
- Debugging Status Key
- Debugging Indicator
- Start Indicator
- Start Control Key
- Query Control Key
- Zero Setting Control Key
- Calibration Function Key
- Reset Control Key
- Product Name
- Manufacturer

Function description

- Revolution number display

3-digital LCD to indicate preset revolution numeric or actual revolution numeric.

- Rotate speed number display

3-digital LCD indicates preset rotate speed numeric or actual speed numeric.

- Revolution button

Revolution button is to preset revolution numeric. Press this button, can preset revolution numeric, with beep sound.

- Start button

Start button is to control rotation part / transmission system status. Press this button, can start/stop rotation part and transmission system, with beep sound.

- LCD Screen

Starting from the need of large amount of information and high intelligent matching the high resolution LCD screen, the user can according to the screen prompt enjoy intelligent operation, each process characters suggest and quantitative indicators are given.

- Debugging Status Key

Debugging Status Key is a function key to start the non-measurement status. Only by entering this status can we achieve the zero setting and benchmark calibration of the instrument.

- Debugging Indicator

Debugging Indicator is an indicator displaying the system's working status. When the indicator is on, it indicates that the system is in the setting status. In this status, zero setting and calibration work can be performed. Besides, there is no peak lock function in this status. When the indicator is off, it is in the status of normal hardness test.

- Tablet Number / Page-turning Control Key

When you press the Model / Down Key, you may cycle the option system and choose the single-tablet mode or the group multiple-tablet test mode.

Single-tablet test mode: 1 tablet is tested every time; group multiple-tablet test mode: there are 10 methods, including 10, 20, 30, 40, 50, 60, 70, 80, 90 and 100; a certain number of tablets will be measured for each group, and data statistics and data processing are carried out for each group of the test data.

In the query status, this key is used as a page-turning key for querying the test data of several trials, and the page-turning function can be recycled.

- Start Indicator

Start Indicator © is the indicator displaying the system's working mode. There are start and stop modes. When Start Indicator is on, it indicates that the system is in the test mode. When Start Indicator is off, it indicates that the system is in the stop mode.

- Start Control Key

Start Control Key is a function key of testing status for the control system. Press Start key, and you can start the system and start the system; repress Start key, you can stop the test.

- Query/Printing Control Key

Query/Print Control Key is a function key for the control system to query the previous test data or print data. When pressing Query Control Key after completing the test, you may query the previous experimental data. If you want to print, press Query Control Key again to print the experimental data.

- Unit Conversion Key

Hardness Unit Conversion Key is to achieve the conversion of hardness measurement unit in Newtons (N) and kilograms (KG). This function can be used before and after measurement.

- Reset Control Key

When Reset Control Key resets, it is a function key of testing status for the control system. Press Reset key, you may stop the test and return to the original state.

- Zero Setting Key

Zero Setting Key: When the instrument is not tested and the hardness value is not zero, press this key, then the screen resets and displays 0000. This function should be used in the calibration status.

- Calibration Function Key

Calibration Function Key is to calibrate the instrument's benchmark parameters. This function should be used in the calibration status.

- Power on switch

Power on switch is main power switch, in on position, tester is in stand by status, OFF position, tester stop working.

Before connecting to AC power, please ensure it's in OFF position!

- AC socket

Ac socket is connected to the power supply with power cord offered in this tester.

Fuse is under the ac socket, attached one 1A fuse and backup one is offered. This is to prevent damage to this tester in suddenness case happened.

Please make sure ac power supply is connected properly !

When change fuse, make sure same spec part is used for tester safety !

- Control system

Control system is composed of transformer, control board, display board. It controls other part of the instrument in working step.

- Sensor unit consist

Sensor unit consist of precision pressure sensor. It changes pressure into electronic signal.

- Composed

Composed of motor and transmission set, transmission unit is used to add pressure on tablet.

- Probe unit consist

Probe unit consist of probe and plate etc. Probe is connected to transmission unit. Plate is connected to sensor unit and used to place tablet. Special attention must be paid on the pressure added on the probe and plate. The pressure must be less than 20KG.

Specification

Model	PJ-2D
Drum	2
Drum's radius	Dia. 286 mm
Drum's depth	39 mm
Tablet falling height	156 mm
Rotation count	100 r
Rotation speed	25 rpm
Speed regulator accuracy	±1 rpm
Hardness range	2~199.9N (50Kg, 499.9N is optional)
Probe procession range	3~40 mm
Power of the heater	500W
Power	220V/ 50Hz or 110V/ 60Hz/ 600W
Dimension	360×450×350 mm
Weight	15 Kg

Environment requirement

Usage temperature	+18°C ~ +28 °C
Store temperature	-10°C ~ +50 °C
Humidity	20% ~ 80 % RH

Installation

Checking

Open the package and take out manual, tester, and accessories. Check items according to packing list. If any mismatch/damage happened, please contact marketing department immediately.

Tester settle

Tester must be placed on stable work station/ table and put damping pad between table and tester.

Clean tester periodically to assure the instrument in normal operation.

Connect to the power supply

Connect the socket & AC power supply source with attached power cord.

Calibration

Zero Setting of Hardness

Turn on the instrument. After 20 minutes preheat, press the Debugging Status Key“Debug”, and make the instrument enter the debugging status; press the Zero Setting Key“Zero” and set the hardness value to be 000.0N (00.00KG). press Debugging Status Key“Debug”again, and exit the debugging status, hardness zeroed is completed.

Hardness Correction

- ① The user shall install Weight Hook on the Correction Lever on the left side of the instrument.
- ② Hold the instrument by hand and set it vertically, so that the left side is placed down on a flat soft table and Weight Hook is exposed outside the table.
- ③ Start up, press the Debugging Status Key, and make the instrument enter the debugging status; press the Zero Setting Key and set the hardness value to be 000.0N (00.00KG).
- ④ Hang 5KG standard weight on Weight Hook, and the hardness value should be 049.0N ($\pm 0.5N$). Be careful to operate it and do not collide it with force.
- ⑤ If the displayed value is incorrect, press Calibration Function Key, and set the hardness value to 049.0N ($\pm 0.5N$)
- ⑥ Remove 5KG standard weight, press the Zero Setting Key, and set the hardness value to 000.0N.
- ⑦ Repeat steps ⑤~⑥ until the value reaches 000.0N in unloading and reaches 049.0N in loading.
- ⑧ Place the instrument on the table horizontally, press Debugging Status Key, and exit the debugging status until the hardness correction is completed.

PS: After the calibration, if the display is “--- N”, press Debugging Status Key AGAIN, and press Zero Setting Key, then press Debugging Status Key.

Operation

Power on

Turn the power switch to ON position, the indicator light, initialize the tester for 10 minutes,

then it's readiness.

Mode preset

The system is in initialize status after turn on the instrument. The default mode is single test mode, that is only test one tablet each time.

If you want to change the default mode, press the MODE button and the mode changes into multi-group test mode, that is test 10 tablets in every testing time. Press the MODE button repetitively, the mode can be in turn changed into 1、10、20、30、40、50、60、70、80、90、100 per test group mode.

Test

First, place the tablet between the probe and the test plate. Press the START button and the probe move left automatically. The tester begin to test the diameter of the tablet and add pressure onto the tablet while the displayed value come to increased. When the tested tablet is shattered, the displayed value is turned to maximums and locked by the system. The beep sound means the first test is completed and at this time the displayed value is the hardness of the tested tablet.

If multi-group test mode is selected, the instrument begin secondary test automatically. The probe changes direction automatically and move right about 10mm. Then the probe changes direction and move left to begin the secondary test. In this process, clean the shattered tablet with the attached brush and place the second tablet on the test plate.

In multi-group test mode, the displayed amount of the tested tablet decreased after each test. The displayed amount is the remainder of this tested group.

Power off

Turn power switch to OFF position, the indicator is off, tester stop working.

Demonstration

- ① Power on and preheat the tester.
- ② Zero adjustment.
- ③ Preset the mode.
- ④ Place the tablet on the test plate, begin testing and read the hardness.
- ⑤ Clean the shattered tablet.
Please repeat step ④ when in multi-group test mode.
- ⑥ Print out test result after multi-group test.
- ⑦ Same with above portion repeat 2-4 steps.
Clear test, please press reset button.
- ⑧ Turn off the tester after test completed.

Maintenance

Must clean box and parts periodically, do not use steel brush, it result in damage to the tester. After each test, pls. Clean up probe unit and transmitter unit and make sure it is clean enough to avoid damage to the tester.

Unpacking and Inspection

Open package, take out manual, tester, and accessories; and check items according to

packing list. Any mismatch/damage happened, please contact sales department immediately.

Tester settled

Tester must be placed in stable work station/ table and put damping/ rubber pad between table and tester.

Install the rotation part (don't confuse left & right side) onto the level axis and lock them.

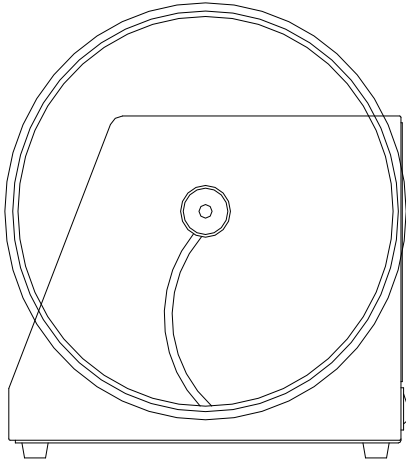

Right

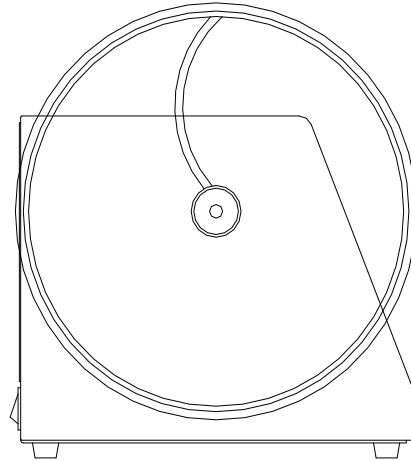

Left

The bolts on the left and right side are fasten by front rotate and loosen by back rotate.

Minimum space required around tester is 0.5m, to ensure heat escaping, clean tester periodically to prevent dusty affect normal operation.

Connect to the power supply

Connect the socket & AC power supply source with attached power cord.

Operation

Power on

Turn the power switch to ON position, the indicator light--initializes the tester for 10 minutes, then it's ready for operation.

The first status is reset position, revolution numeric is auto set to 100R, the rotation speed is 25RPM.

Revolution preset

The first status is reset position, revolution numeric is auto set to 100R.

If you want to change the revolution numeric, press the REV button first, then the revolution numeric changes to 110R. Repeat the revolution numeric changes to 120R. The revolution numeric changes accordingly when press the button continuously. The revolution numeric display changes follow it. The button changes loop.

Rotation count: 10-900R.

Test

Put the rotation part off and open the cover, put in 6.5G sample material and close the cover, put it onto the level axis and lock the bolts. Press start button, the test process is begins. After 100R rotating at 25RPM, the rotation part stops to measure the sample's friability.

Troubleshooting

- Can not power on

Check whether the voltage is OK and fuse is OK. Please refer to the rating marked in nameplate while installation.

If the tester does not work after checking above items, please don't repair it by yourself, contact our market department please.

Packing list

The PJ-2D Tablet Dual-usage tester include following items typically:

- Tester _____1
- Power cord _____1
- Brush _____1
- Box _____1
- Hook _____1
- Rotation accessories _____2
- User's manual _____1
- Product quality guarantee _____1
- User registration card _____1

Product quality guarantee

- This quality guarantee covers the scope of PJ-2D Tablet Dual-usage tester.
- Start from purchasing date; warranty period is one year.
- This quality guarantee is effective from receiving registration card filled by users.
- During warranty, we offer free charge service for troubleshooting under normal operation, but for any cases caused by flood, fire, earthquake, or other calamity, is excepted.
- During warranty, under the one of the following cases, we will consider to charge material/service fee to users:
 - No product quality guarantee, mismatch with this guaranty or wrong record/remark.
 - Not follow the using environment required in user's manual.
 - Disassembly, install, extend, move or modify this tester without our permission.
 - Unqualified technician repairing without permission.
 - Keep this guarantee in proper place and no reissue is promised.
 - The guarantee is only applicable in Chinese mainland.

Using instruction

- Proper operation & maintenance will ensure instrument usage life, please follow users manual's instruction.
- When the power supply is unstable, pls. Use AV regulator, and special notice the information related to power supply, temperature, humidity in the manual.
- Always keep instrument clean. Disassembly/move any parts of this tester is prohibited.
- In case of trouble found, pls. Stop using, inform dealer or company with model, S/N, and phenomenon.

Registration card

<u>Name</u>	
<u>Address</u>	
<u>ZIP</u>	<u>E-mail</u>
<u>Tel</u>	<u>Fax</u>
<u>Product</u>	
<u>Model</u>	<u>S/N</u>