

Disintegration Tester BJ-1

User's Manual

Shanghai Lorderan Scientific Instrument Co., Ltd.

Table of Contents

Table of Contents 1

Introduction..... 2

Product registration..... 2

Technical service 2

Proper operation..... 2

Contact Us..... 2

Introduction..... 3

Brief introduction..... 3

Function description..... 4

Specification 5

Environment requirement 6

Power supply..... 6

Installation..... 6

Unpacking and Checking..... 6

Tester settle 6

Connect to the power supply 6

Bath box..... 6

Cycle liquid..... 6

Refill cycle liquid 7

Empty cycle liquid..... 7

Instead cycle liquid..... 7

Operation 7

Power on..... 7

Time preset 7

Temperature control 7

Test..... 7

Power off 7

Demonstration 8

Maintenance 9

Troubleshooting 9

Packing list..... 9

Product quality guarantee 10

Using instruction 10

Registration card 10

Introduction

Thanks for purchasing the product BJ-1 Disintegration tester designed and manufactured by us. Please read user's manual carefully before using the product. It will help you operate it properly and efficiently.

Product Registration

Prior to use the product, please fill up the user's registration card and mail to us, in order to get our service in future.

Technical Service

Pls. contact our marketing department for any service during warranty. Be sure that you have sent back the user's registration card.

If you have any problems, Pls. Try to find answers in user's manual first, or you can call our marketing department.

Proper Operation

Make sure you have read this manual carefully before installing/operating the instrument. For any concerns pls. Contact us.

- Transport with care. Any incline, convert, and hit are prohibited.
- Check and protect all safety related labels.
- It is prohibited to use any damaged product and power cord.
- Turn off the power before maintenance, or moving.

Contact Us

Shanghai Lorderan Scientific Instrument Co., Ltd

Office Address: Room 1508, No. 32, Lane 3128 Middle Chengliu Road, Shanghai

Factory Add: No.16 Zhangye Road, Fengxian District, Shanghai

Tel/Fax: 021-51268189, 61732073 (P.C 201822)

Email: sales@lorderan.com

www.lorderan.com/

Introduction

Brief introduction

BJ-1 Disintegration tester consists of control system, transmission system, constant temperature baths system, and nacelle unit etc. And central controlled by MPU. The features: reasonable structure, automatic and simplified operation, high accuracy and sensitivity, and stable performance.

BJ-1 Disintegration tester main box consist of bottom, foot, box, front panel, rear panel etc.

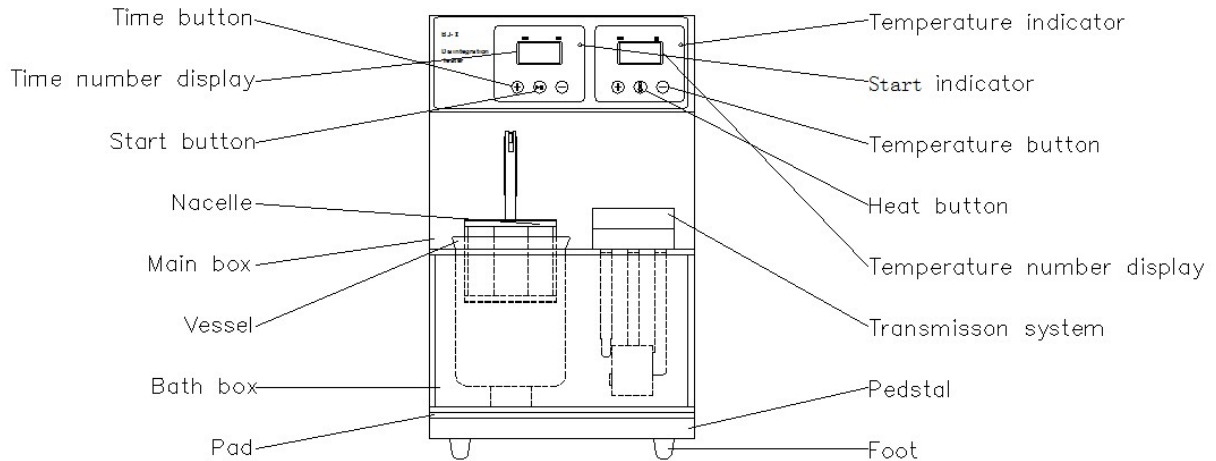

Front panel includes:

- Temperature number display
- Time number display
- Time button
- Heat button
- Start button
- Temperature button
- Heat indicator
- Error indicator
- Product model
- Manufacturing

Rear panel includes:

- Power on switch
- AC socket(fuse jack included)
- Name plate

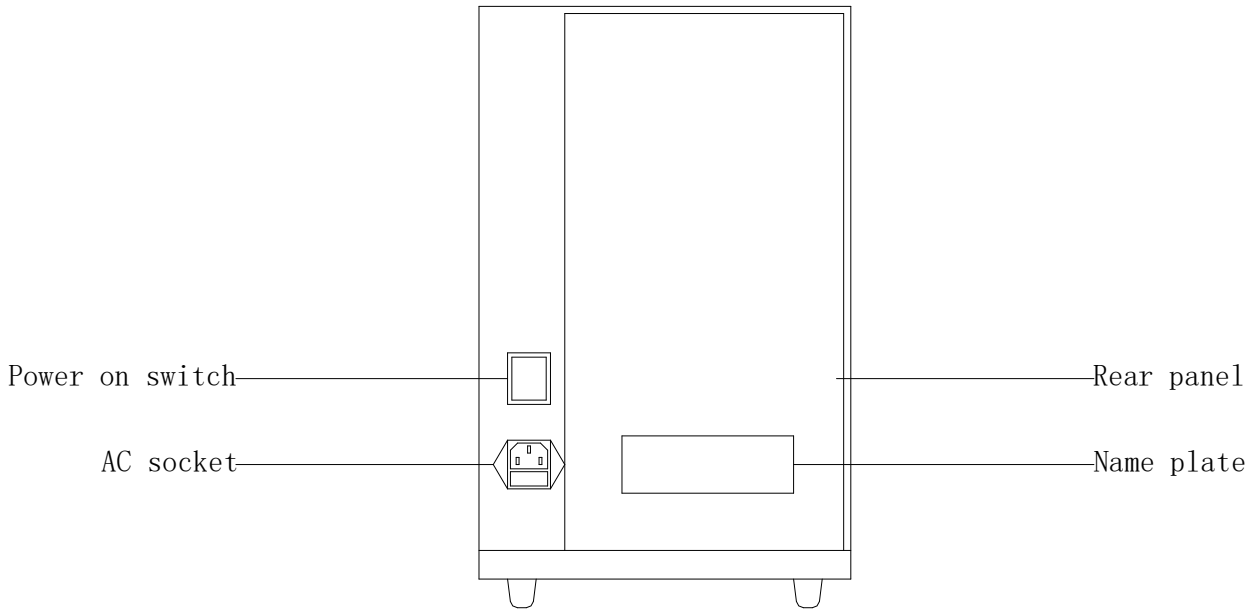

Function description

- Temperature number display

Three LCD in the temperature display area are used to display the preset temperature or the actual temperature. The unit of temperature is centigrade(°C).

- Time number display

3-digital LCD indicates the preset time or actual time.

- Time button

Timing adjusting button for adjusting the timing, time function keys.

Start the machine, time display window shows the preset time value (default 15min boot). If you need to change the value preset time, then click a timing adjustment (+) key, the preset time value is 16min; if you press the timing adjustment (-) key, the preset time value is 14min; continuous on the timing adjustment button, then the preset time numerical continuous change; time display window shows the time value and corresponding changes.

Automatic return real time state preset is completed in about 2 seconds system

The time presetting range is 1 ~ 900min.

1 ~ 30min per click timing adjustment, increased 1min. 30 ~ 900min per lick time adjustment, increased 5min.

- Heat button

Heat button is used to control the working status of the temperature system. Press this button, can turn on/off automatic controlled temperature system, with beep sound.

- Start button

Start button is used to control the working status of the nacelle unit and the automatic time unit. Press this button, can turn on/off the nacelle unit and the automatic time unit, with beep sound.

- Temperature button

The temperature preset temperature, as the preset temperature function keys.

Start the machine, the temperature display window shows the current temperature, 2 ~ 3 seconds after the automatic display and preset temperature values (boot default 37 C). If you need to change the value preset temperature, then click a temperature regulation (+) key, the preset temperature value is 37.5 °C; if press temperature regulation (-) key, the preset temperature value is 36.5 °C; continuous on the temperature adjusting button, the preset temperature numerical continuous change; temperature display window to display the temperature and the corresponding numerical change.

The temperature range of RT. ~ 45 °C preset.

- Heat indicator

Heat indicator indicates the working status of the system. When it light, it means the system in automatic controlled status, otherwise, it means the system in uncontrolled status.

- Error indicator

Error indicator indicates the working status of the system. When it light, it means the system in abnormal working status, otherwise, it means the system in normal working status.

- Power on switch

Power on switch is the main power switch. In ON position, tester is in working status, inversely, tester stop working.

Before connecting to AC power, please ensure it's in OFF position!

- AC socket

AC socket is connected to the power supply with power cord offered in this tester.

Fuse is under the AC socket. Attached one 3A fuse and a backup one is offered. This is to prevent damage to this tester in suddenness case.

Please make sure AC power supply is connected properly!

When change fuse, make sure same spec part is used for tester safety!

Specification

Model	BJ-1
Testing Station	1
Volume of Beaker	1000 ml
Speed	30~32 /min
Height of Stroke	55±1 mm
Timing Range	1~900 mins
Temperature	Rt~45 °C

Accuracy of Temperature	±0.5 °C
Continuous working time	>24hr
Power Supply	220V/ 50Hz, 110V/ 60Hz
Power	600W
Dimension	260×320×420 mm
Weight	10 kg

Environment requirement

Usage temperature	+18°C ~ +28°C
Store temperature	-10°C ~ +50 °C
Humidity	20% ~ 80 % RH

Installation

Unpacking and Checking

Open the package, take out manual, tester, and accessories. And check items according packing list. Any mismatch/damage happened, please contact marketing department immediately.

Tester settle

Tester must be placed on stable work station/table and put damping pad between bath box and tester.

Place the burning cups in bath box with the gap backward.

Hang the nacelle unit on the hook in front of the tester.

Minimum space required around test is 0.5m, to ensure heat escaping. Clean tester periodically to prevent tester from abnormal operation.

Connect to the power supply

Connect the socket & AC power supply source with attached power cord.

Bath box

Constant temperature bath system is composed of bath box, heater and cycle water pump. It used to supply high efficient bath.

DON'T switch on the machine if without water.

If the water level in bath box were lower that the pump would spout bubble when running. Fill water in the bath box.

Cycle liquid

Suggest using distillation water.

Refill cycle liquid

Clean up the bath box and pour into the cycle liquid until it come to the calibration.

The scale mark is the filled height without beakers in bath box. You can turn on the heat system after the liquid level is raised with beakers in bath box. Otherwise the heater part may be damaged.

Empty cycle liquid

Get out the nacelle unit and burning cup. Insert the plastic pipe into the cycle liquid in the bath box and the other end is out of the bath box and below the working table. Empty the water with aspirator and clean up the bath box.

Change cycle liquid

Change cycle liquid can be completed by repetitively operate the empty and fill procedures.

Operation

Power on

Turn the power switch to ON position, the indicator light, initialize the tester for 10 minutes, then it's readiness.

Preset parameter

When power turns on, the system is first in the presetting state and the default parameters are as follows: temperature 37.0°C, time 015min.

Press TEMP button to preset temperature.

Press TIME button to preset the time.

Temperature control

When power on, it's in initial status, system auto-set to 37 degree, LCDs show the actual temperature of liquid in bath box. The system is in initial status after turning on the tester. The default preset temperature is 37.0°C. LCD shows the actual temperature of liquid in bath box.

Press HEAT Button and the indicator light. The system begins heating and automatically controlling the temperature. After about 30 min, the temp stabilize at range of $37\pm 0.5^{\circ}\text{C}$.

Test

Put the 6 samples into the 6 tubes of the nacelle and hang onto the hook. Press START button, nacelle is moving up and down to test till the time is over. Then read the measurements about the samples.

Power off

Turn switch to OFF position, the indicator is off and tester stop working.

Demonstration

① Power on.

- ② Set time
- ③ Press the temperature button.
- ④ After the temperature stabilization, adjust the temperature to zero when it is necessary.
- ⑤ Place the sample into tube of the nacelle and hang the nacelle onto the hook.
- ⑥ Press start button, the nacelle move back and forth to begin testing.
- ⑦ The nacelle stop moving till the preset time. Read the measurement of the sample.
- ⑧ Same measurement can be completed by carry out 5-7 repetitively.

Maintenance

Clean box and parts periodically. Do not use steel brush, it will result in damage to the tester. After testing every time, pls. Clean nacelle unit etc to avoid damage to the tester.

Troubleshooting

- Can not power on

Check whether the voltage is OK and fuse is OK, please refer to the rating marked in nameplate while installation.

If the tester does not work after checking above items, please don't repair it by yourself, contact our market department please.

Our testing instruments are built to last with low maintenance require, high accuracy, easy to operate and most reliable testers in the industry.

Packing list

The BJ-1 Disintegration Tester include following items typically:

- BJ-1 Disintegration Tester1
- Power cord1
- Nacelle units1
- Discs6
- 1000ml beaker1
- Damping pad1
- Plastic pipe1
- Aspirator1
- User's manual1
- Product quality guarantee1
- Registration card1

Product quality guarantee

- This quality guarantee covers the scope of BJ-1 Disintegration tester.
- Start from purchasing date; warranty period is one year.
- This quality guarantee is effective from receiving registration card filled by users.
- During warranty, we offer free charge service for troubleshooting in normal cases, but for any cases caused by flood, fire, earthquake, or other calamity, is excepted.
- During warranty, in one of the following cases, we will charge for material/service:
- No product quality guarantee, mismatch with this guaranty or wrong record/remark.
- Damages caused by unusual working environment.
- Damages caused by disassembly, install, extend, move or modify without our permission.
- Damages caused by repairing without our permission.
- Keep this guarantee in proper place and any other issue is provided.
- The guarantee is only applicable in Chinese mainland.

Using Instruction

- Proper operation & maintenance will prolong the working time of the instrument. Please follow the manual's instruction carefully.
- When the power supply is unstable, pls. Use AV regulator. Pay special attentions to the information related to power supply, temperature, humidity in the manual.
- Always keep the instrument cleaning. Disassembly/move any parts of the tester is prohibited.
- In case of trouble present, pls. Stop using, call us or dealer for help.

Registration card

Name	
Address	
ZIP	E-mail
Tel	Fax
Product	
Model	S/N