

PART NUMBER DESCRIPTION TABLE					
P/N	DESCRIPTION	L ± .030	PRE-COILED Y/N	# OF WRAPS	I.D OF WRAPPING
VGL610-057	MICRO BAND	8.125	NO	0	N/A
VGL610-057-A	MICRO BAND PRE-COILED	8.125	YES	2	.875 MAX
VGL610-083	MICRO BAND EXTENDED LENGTH	14.25	NO	0	N/A
VGL610-083-A	MICRO BAND EXTENDED LENGTH PRE-COILED	14.25	YES	2	1.875 MAX

REV	DESCRIPTION	DATE	INITIALS
A	INITIAL RELEASE (EWOM# 2015-005)	4/20/15	JGF
B	ECO 2016-003	8/8/16	JGF

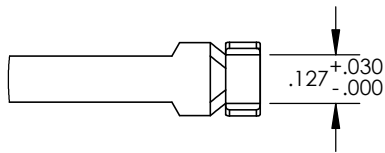

DETAIL B  
SCALE 2 : 1

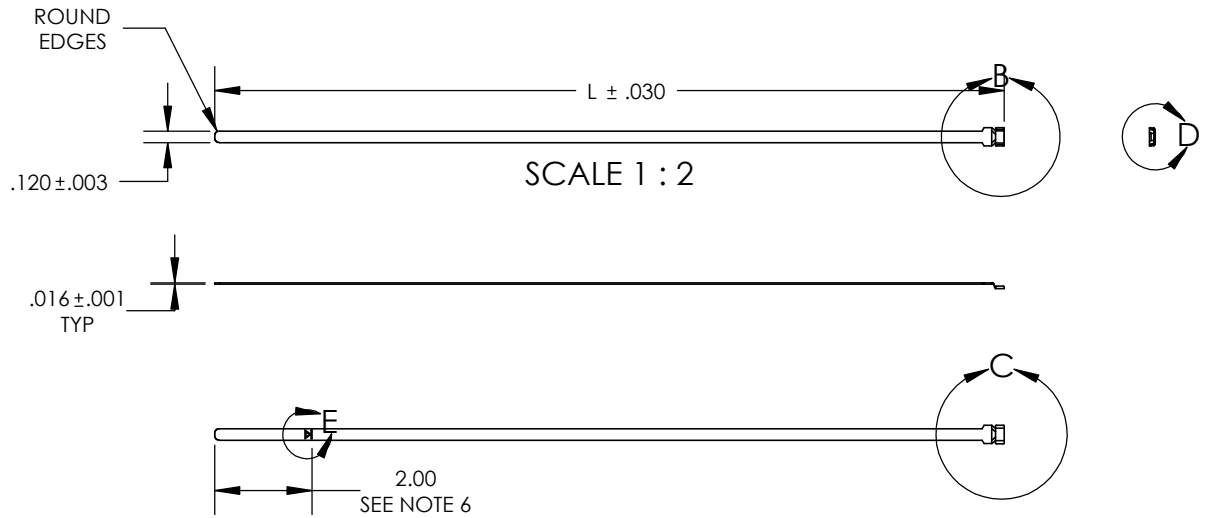
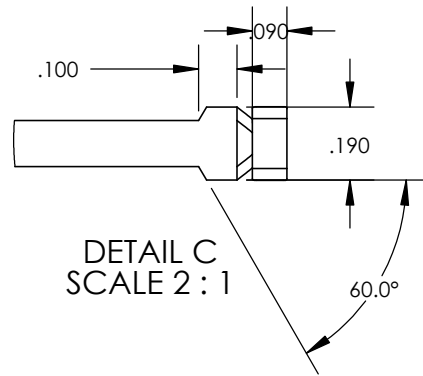

DETAIL C  
SCALE 2 : 1

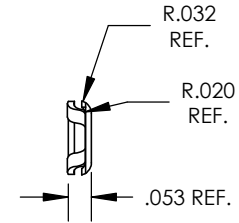

DETAIL D  
SCALE 2 : 1



DETAIL E  
SCALE 2 : 1

**NOTES:**

- DRAWING TO BE INTERPRETED PER ASME Y14.5
- MATERIAL: 300 SERIES STAINLESS STEEL W/ PASSIVATION AND HEAT TREATMENT
- ALL PARTS TO BE FREE OF OIL, GREASE, DIRT, AND/OR ANY FOREIGN MATERIALS
- ALL SHARP CORNERS TO HAVE .005" MAXIMUM RADIUS (UNLESS OTHERWISE SPECIFIED)
- NO BURRS PERMITTED
- STAMPED TAIL LENGTH INDICATOR, DEPTH OF STAMP .001/.003", BACKSIDE MUST BE SMOOTH WITH NO PROTRUSION FROM STAMPING

NAME		DATE	<b>ALLIED CONNECTORS</b>	
DRAWN	JGF	4/20/15		
CHECKED	BP	4/20/15	TITLE:	
<small>PROPRIETARY AND CONFIDENTIAL THE INFORMATION CONTAINED IN THIS DRAWING IS THE SOLE PROPERTY OF ALLIED CONNECTORS. ANY REPRODUCTION IN PART OR AS A WHOLE WITHOUT THE WRITTEN PERMISSION OF ALLIED CONNECTORS IS PROHIBITED.</small>			<b>MICRO BAND</b>	
<small>UNLESS OTHERWISE SPECIFIED: DIMENSIONS ARE IN INCHES TOLERANCES: FRACTIONAL ±1/64 ANGULAR: MACH ±1° TWO PLACE DECIMAL ±.01 THREE PLACE DECIMAL ±.005</small>			SIZE <b>A</b>	DWG. NO. VGL610-XXX-MICRO
			REV <b>B</b>	SHEET 1 OF 1
			SCALE: N/A	