

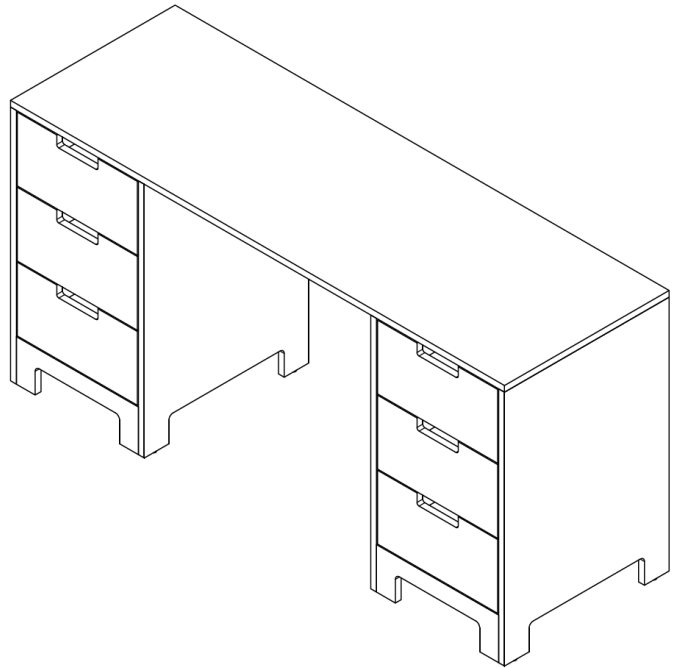

ASSEMBLY INSTRUCTIONS

juno doublewide desk

a how-to guide that won't leave you in tears



parenting is hard.
this is easy.

no really, it is.

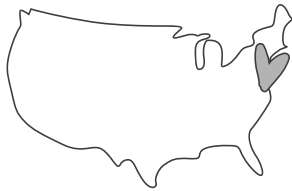

MADE HERE™



MADE WELL™

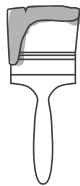

MADE SAFE



MADE SMART

want to watch this assembly IRL?

(acronym challenged? that means “in real life”.)

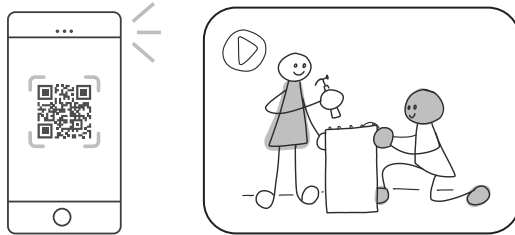

open the camera on your phone and place it over the QR code below to see our NYC studio dream team do all the heavy lifting (just kidding, there is none!)



or go to ducducnyc.com/assembly-instructions

**thank you for selecting a
studio duc product!**

please check contents against the components list in these instructions. also, please ensure there was no damage that may have occurred in shipping.

if any components are missing or you find any damage, please contact ducduc before continuing.

read all the instructions before use.

pay close attention to the safety warnings in these instructions.

a minimum of two people is required to safely assemble and move the desk. do not attempt to move this desk alone — dragging or sliding it across a floor may cause structural damage.

CLEANING:

do not scratch or chip the finish. do not use abrasive chemicals for cleaning. clean with mild soap on a soft rag. rinse and dry thoroughly. if you ever refinish this furniture, be sure to use only a non-toxic finish specified for children's furniture.

KEEP INSTRUCTIONS FOR FUTURE USE

WHAT'S IN THE BOX:

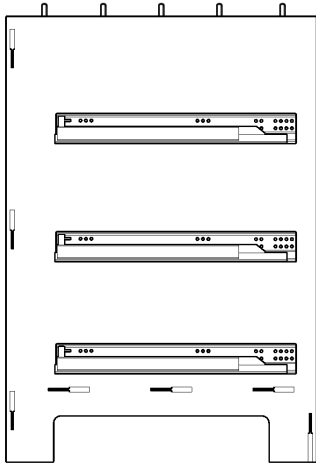

A1 (x2)
R side panel

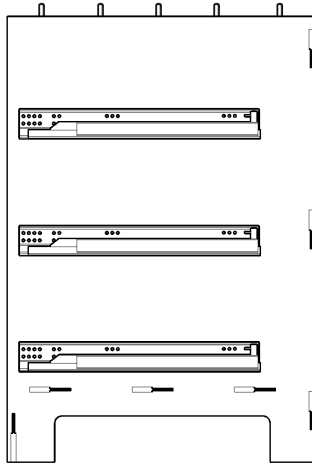

A2 (x2)
L side panel

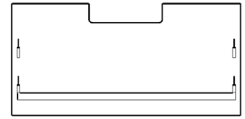

DB1 (x6)
drawer face



DB2 (x6)
drawer box back

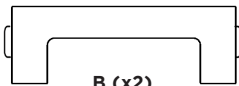

B (x2)
stretcher

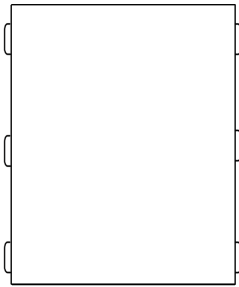

C (x2)
bottom panel

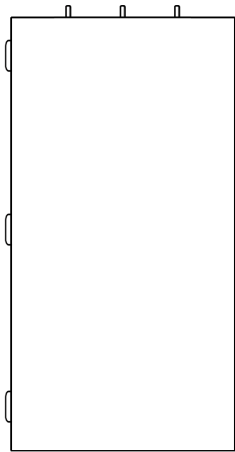

D (x2)
back panel



DB3 (x6)
L drawer box side

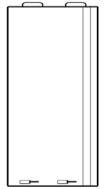

DB4 (x6)
R drawer box side

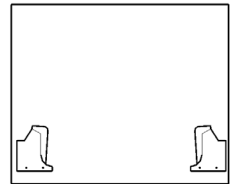

DB5 (x6)
drawer box bottom



E
desktop

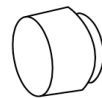

F
hammer cap

WHAT YOU'LL NEED:



**household hammer or
rubber mallet**



20 minutes
(or less)

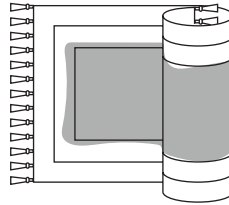

a soft surface to assemble on
*(like a rug or some of the corrugate
box your piece arrived in)*



2 people
plus a dog for moral support
(unless you're a cat person)

1 lean one R side panel (A1) against a wall as shown.

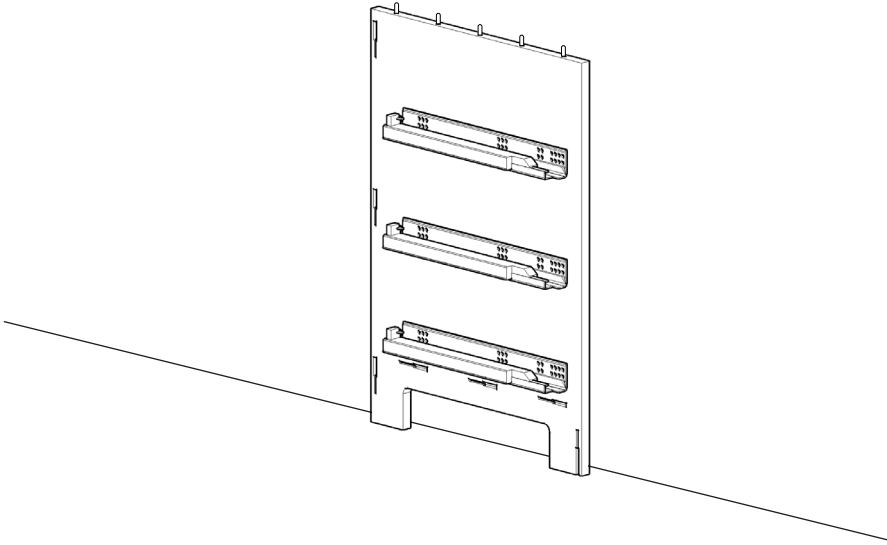

2 insert connectors on one back panel (D) into slots on R side panel (A1). push down at the connection to lock into place.

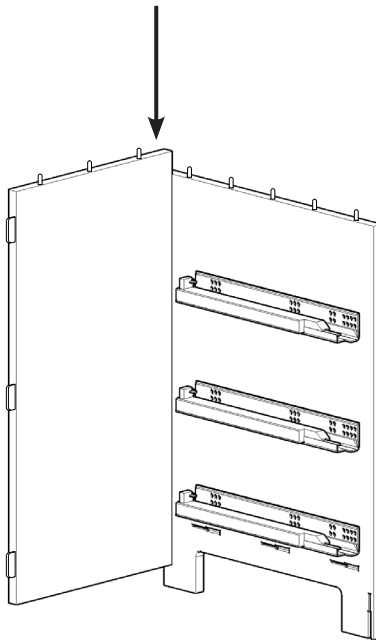

still confused? scan this code to watch the assembly video! →



3

insert connectors on back panel (D) into slots on one L side panel (A2). push down at the connection to lock into place.

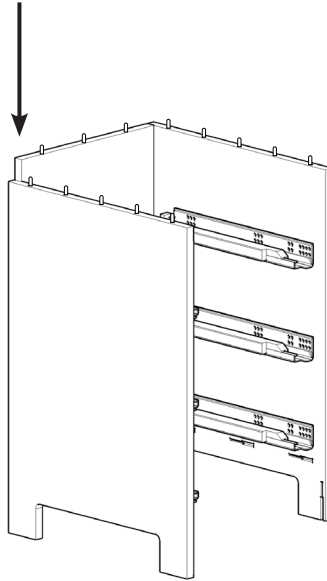

4a

have a friend gently flare R + L side panels (A1 + A2) outward as shown.

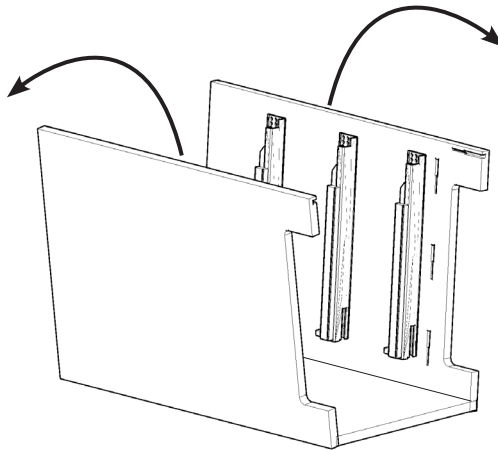

still confused? scan this code to watch the assembly video!



4b

with the side panels flared outward, insert the connectors of one side of bottom panel (C) into slots on R side panel (A1).

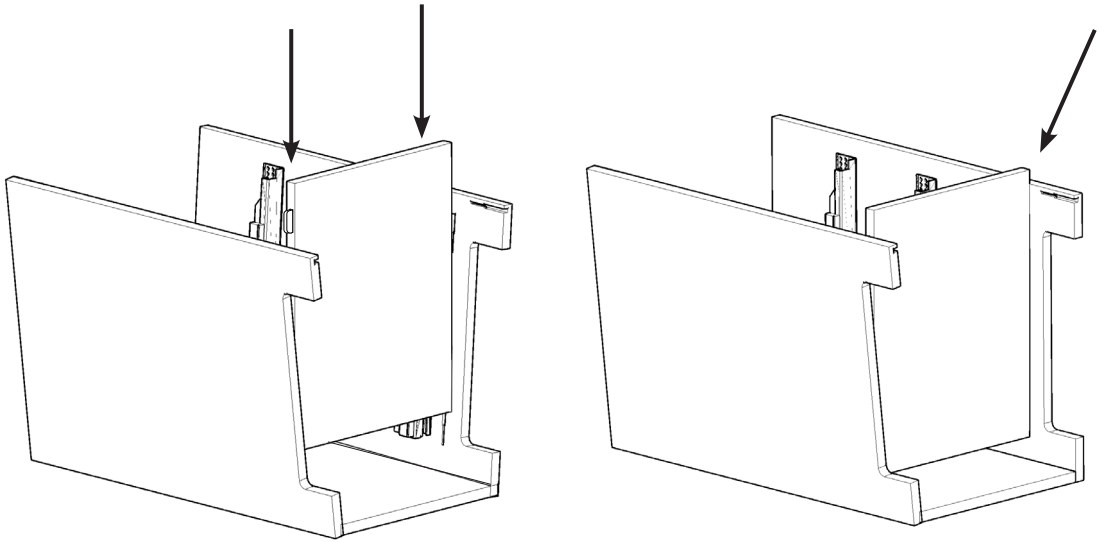

4c

insert remaining connectors of bottom panel (C) into slots on L side panel (A2).

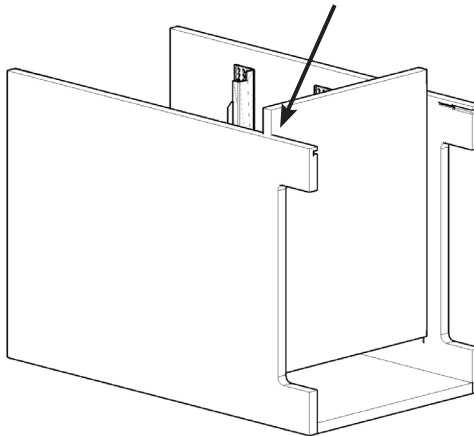

still confused? scan this code to watch the assembly video! →



4d

once all connectors and slots are lined up and side panels are back to square position, apply hammer cap (F) to the head of a household hammer and tap bottom panel (C) until there is no gap at the connection to back panel (D).

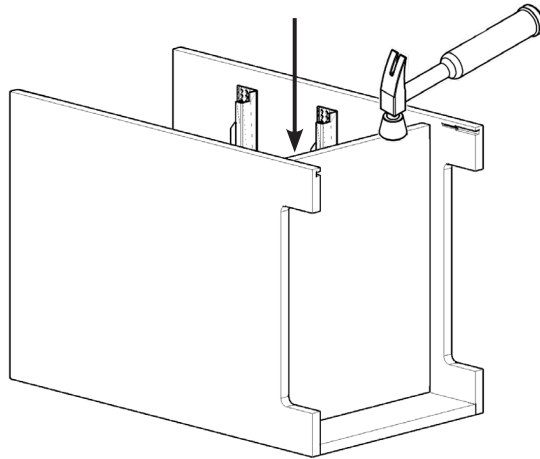

5

insert the connectors of one stretcher (B) into slots on both side panels (A1 + A2). tap with hammer and hammer cap (F) to lock into place.

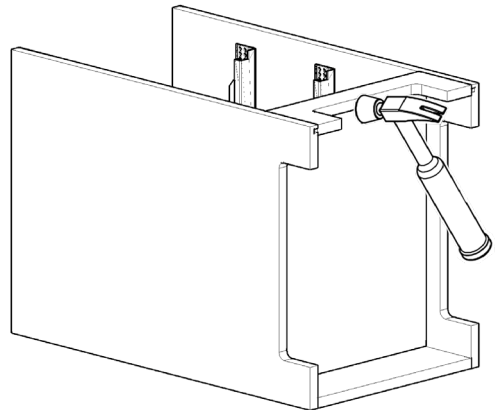
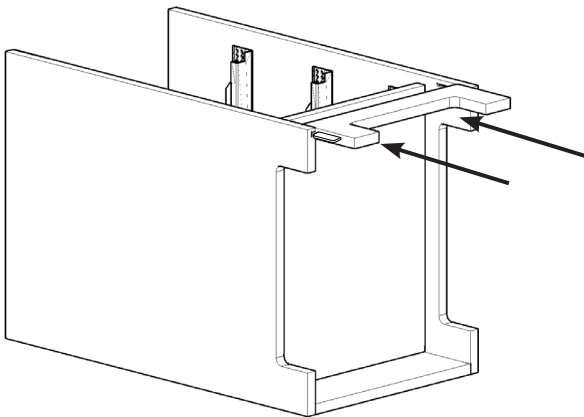

still confused? scan this code to watch the assembly video! →



6

with a friend, flip partially assembled case into upright position.

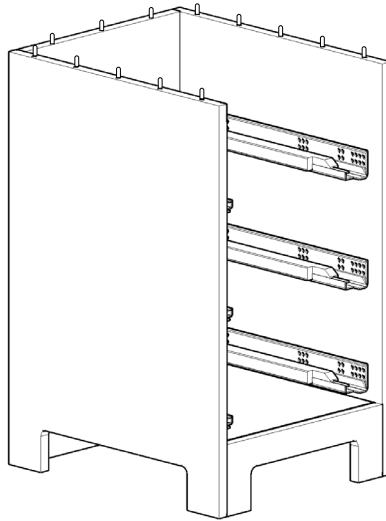

7

repeat steps 1-6 to create the second case from the remaining parts.

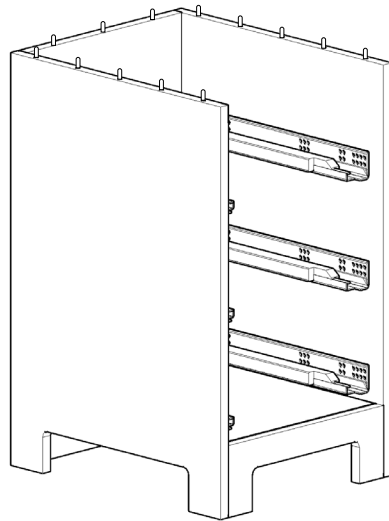
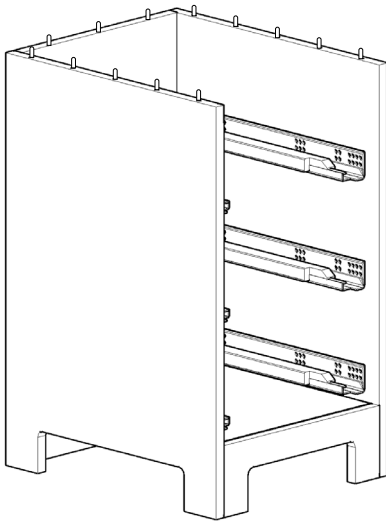

still confused? scan this code to watch the assembly video! →



8a

now we build the drawers! starting with drawer face (DB1) facing down, insert the connectors of both drawer box side panels (DB3 + DB4) into slots on drawer face (DB1). push down at the connections to lock into place.

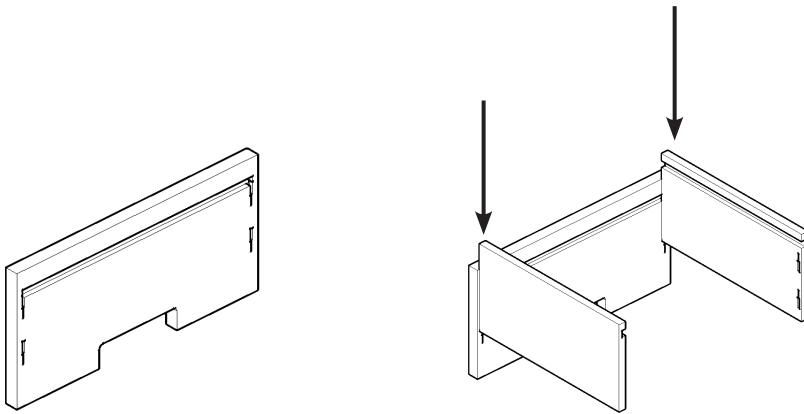

still confused? scan this code to watch the assembly video!



8b

rotate the partially assembled drawer box as shown. slide drawer box bottom (DB5) into place using grooves on the drawer box side panels (DB3 + DB4) as guides. be sure glide hardware on bottom panel (DB5) is positioned outside the drawer interior and toward the drawer face (DB1) as shown.

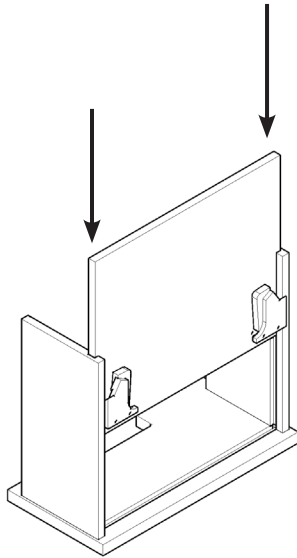

duc insider tip!

when the drawer bottom panel is properly installed, it should be recessed about a 1/4" from the back of the drawer sides. (don't be afraid to use some force!)

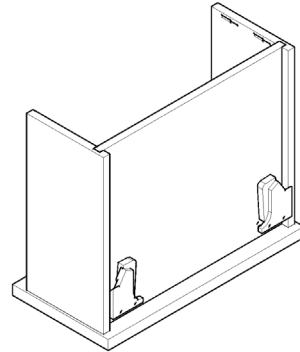

8c

again, rotate partially assembled drawer box as shown. insert connectors of drawer box back (DB2) into slots on drawer box sides (DB3 + DB4). push down at the connections to lock into place. Use hammer and hammer cap (F) if needed.

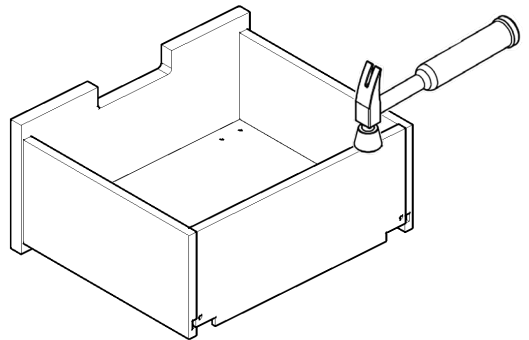
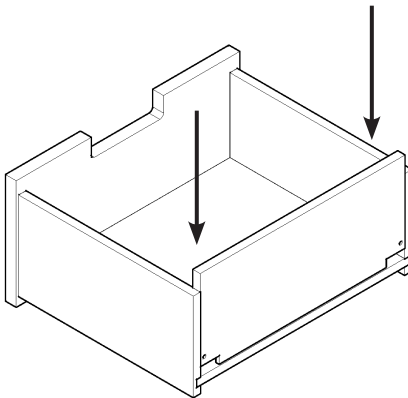

still confused? scan this code to watch the assembly video! →



9

build remaining (5) drawers using steps 8a, 8b, and 8c.

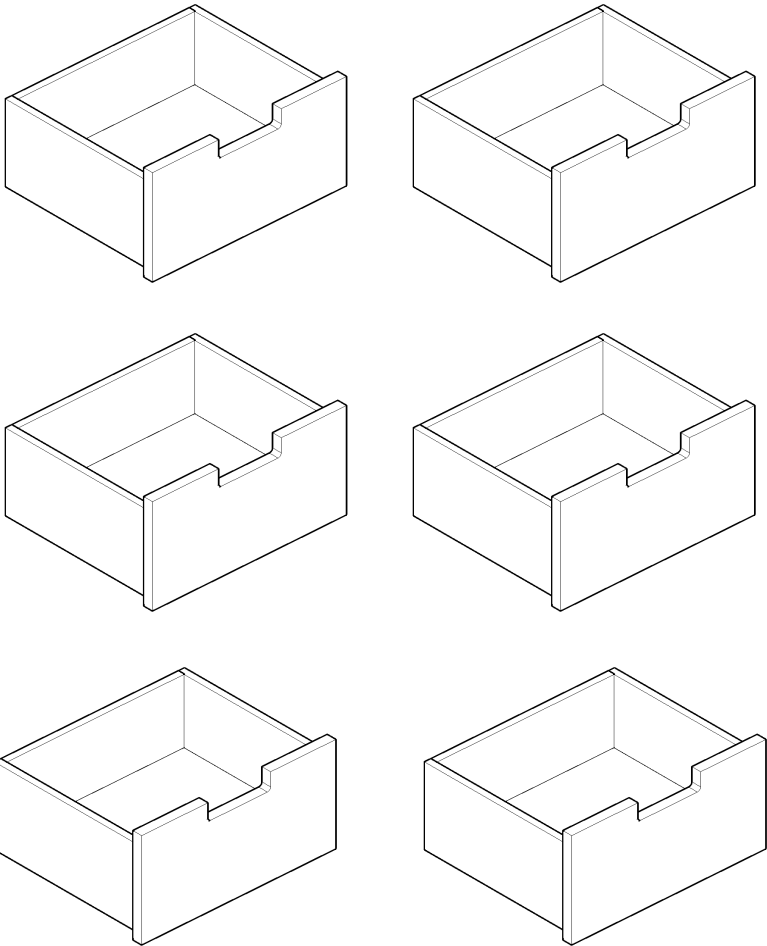

still confused? scan this code to watch the assembly video!



10a

starting at the top of one case, pull drawer glides out to extended position as shown.

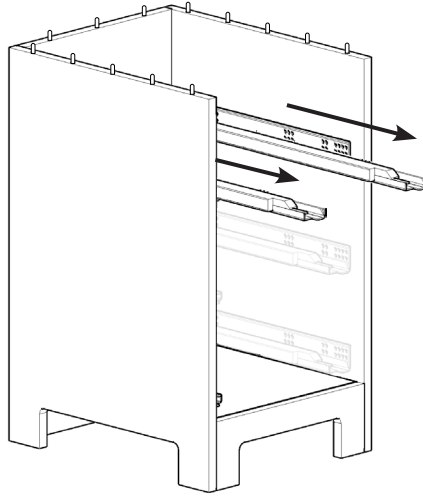

10b

place one assembled drawer box onto extended glides as shown. from underside of drawer, use hands to pull each glide forward until it locks into connection with glide hardware attached to drawer box bottom (DB5). the drawer will be secure when you hear a click on each connection. once secured, push drawer box in to close.

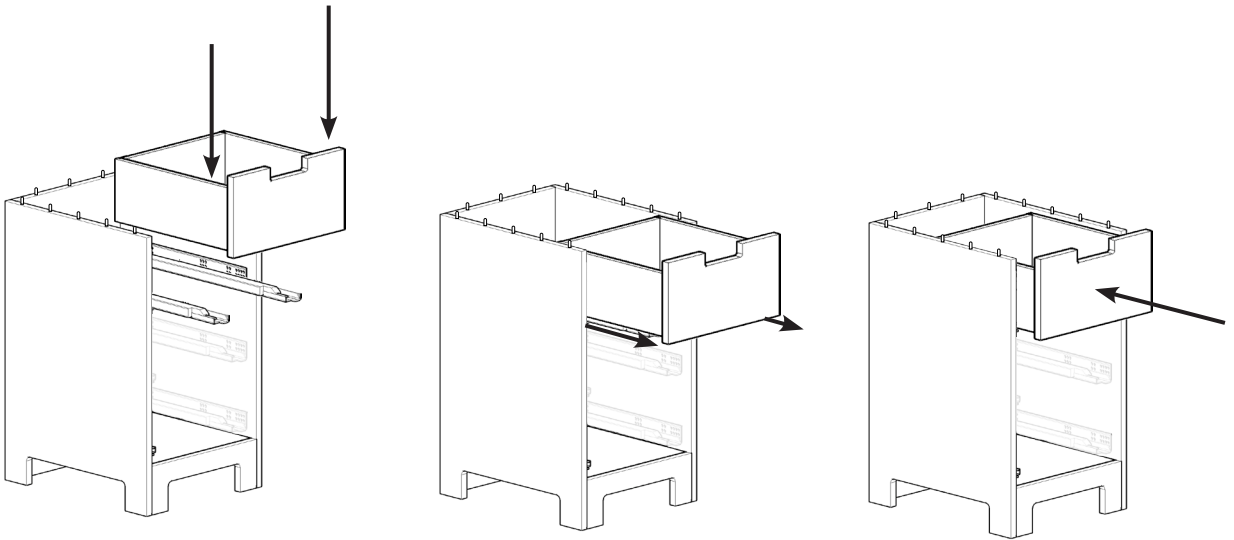

still confused? scan this code to watch the assembly video!



11

repeat steps 10a + 10b to install remaining drawers on both cases. place both cases in the location where the desk will be fully assembled with the cases spaced 60" apart.

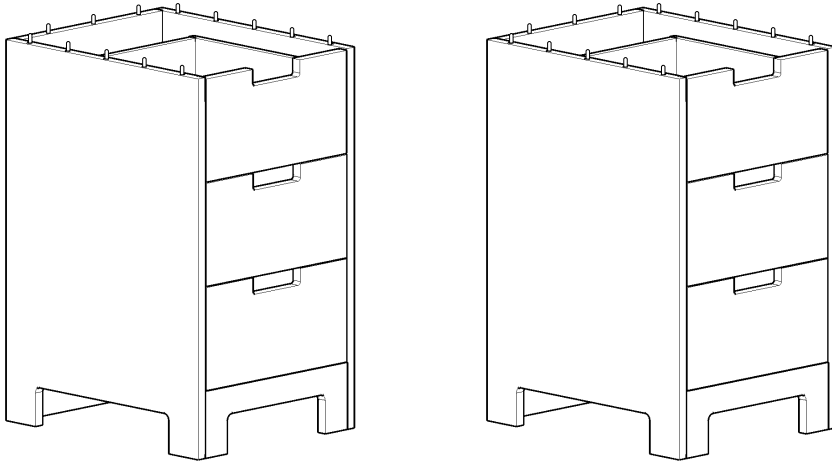

still confused? scan this code to watch the assembly video! —————>



12

with a friend, lift desktop (E) and line up connectors on both cases (A1s, A2s, + Ds) with the holes on the underside of desktop (E). push down at all connections to lock into place.

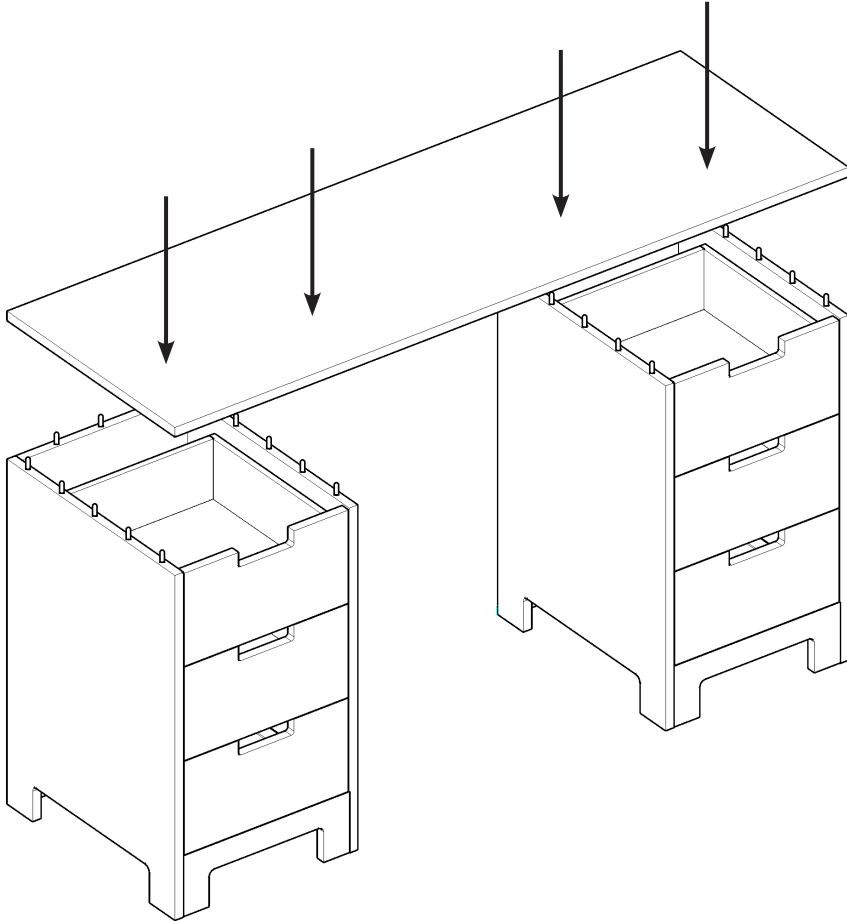

still confused? scan this code to watch the assembly video! →



bravo! you did it!

give yourself a pat on the back, take a bow,
or go house a pint of ice cream...we don't judge.

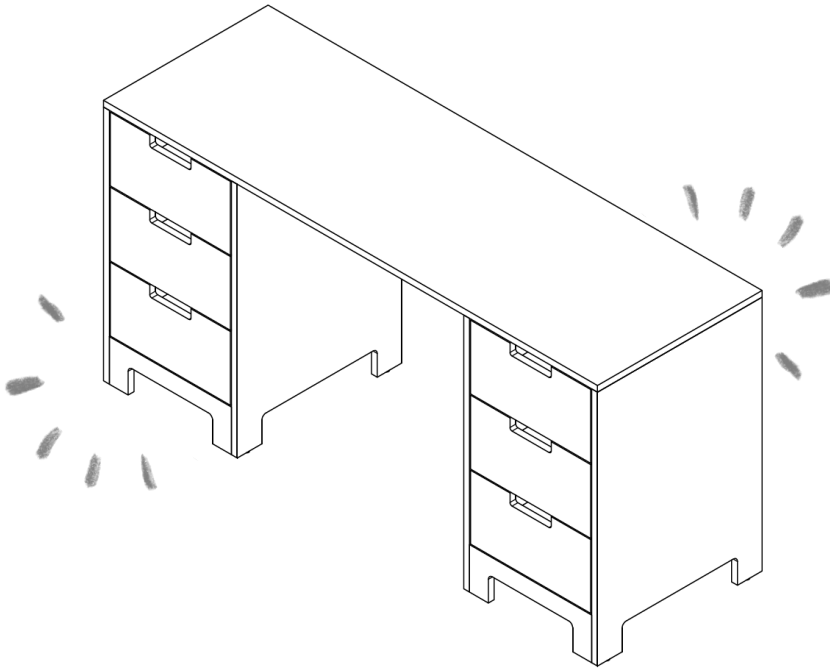

prefer to talk to a human instead? we're here for you!

contact our customer advocate team below:



212.226.1868



quack@ducducnyc.com



live chat at
ducducnyc.com



200 lexington, no. 701
ny, ny 10016