

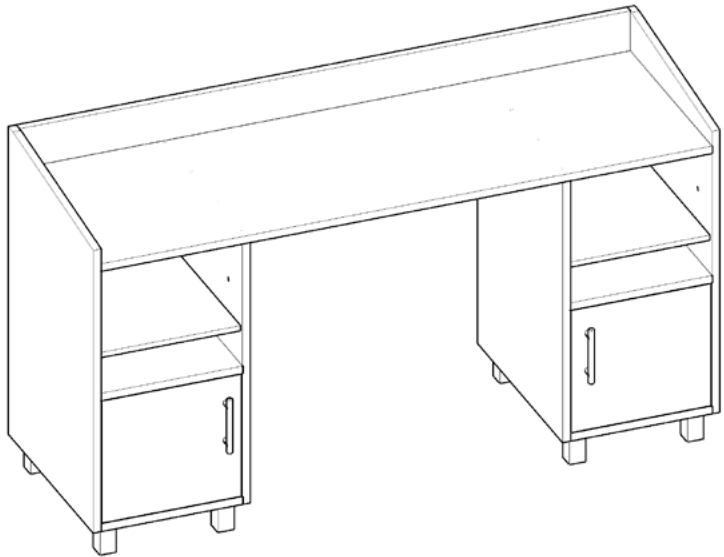

ASSEMBLY INSTRUCTIONS

indi doublewide desk

a how-to guide that won't leave you in tears



parenting is hard.
this is easy.

no really, it is.

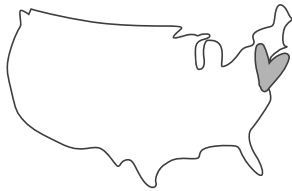

MADE HERE™



MADE WELL™

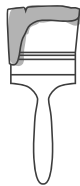

MADE SAFE



MADE SMART

want to watch this assembly IRL?

(acronym challenged? that means “in real life”.)

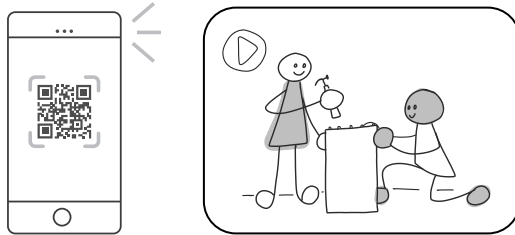

open the camera on your phone and place it over the QR code below to see our NYC studio dream team do all the heavy lifting (just kidding, there is none!)



or go to ducdcnyc.com/pages/assembly-instructions

**thank you for selecting a
studio duc product!**

please check contents against the components list in these instructions. also, please ensure there was no damage that may have occurred in shipping.

if any components are missing or you find any damage, please contact ducduc before continuing.

read all the instructions before use.

pay close attention to the safety warnings in these instructions.

a minimum of two people is required to safely assemble and move the desk. do not attempt to move this desk alone — dragging or sliding it across a floor may cause structural damage.

CLEANING:

do not scratch or chip the finish. do not use abrasive chemicals for cleaning. clean with mild soap on a soft rag. rinse and dry thoroughly. if you ever refinish this furniture, be sure to use only a non-toxic finish specified for children's furniture.

KEEP INSTRUCTIONS FOR FUTURE USE

WHAT'S IN THE BOX:



A
desktop back



B
desktop

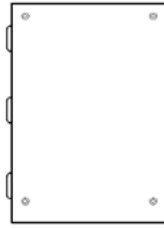

C (x2)
bottom



D (x2)
adjustable shelf



F (x8)
foot



E (x2)
back panel



G (x8)
JCB bolt (25mm)

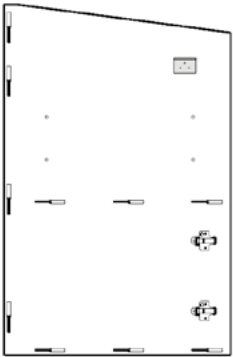

RC1
R case exterior side

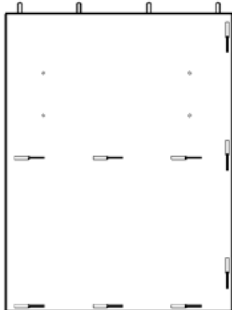

RC2
R case interior side

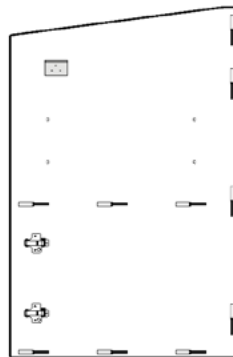

LC1
L case exterior side

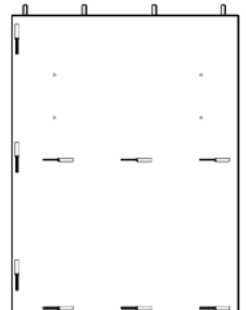

LC2
L case interior side



RC3
R case fixed shelf

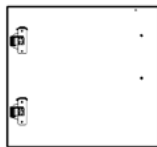

RC4
R case door



LC3
L case fixed shelf

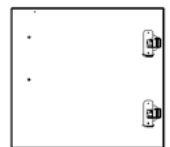

LC4
L case door

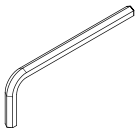

H
allen key (4mm)



I
hammer cap



J (x6)
screw for bracket



K (x2)
indi pull



L (x4)
screw for indi pull

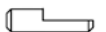

M (x8)
shelf pin

WHAT YOU'LL NEED:



**household hammer or
rubber mallet**



**phillips head screwdriver and/or
drill with 6mm bit**



20 minutes
(or less)

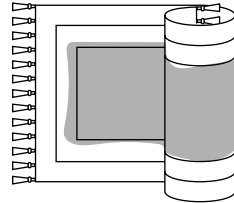

a soft surface to assemble on
*(like a rug or some of the corrugate
box your piece arrived in)*



2 people
plus a dog for moral support
(unless you're a cat person)

1 lean one bottom (C) against a wall as shown.

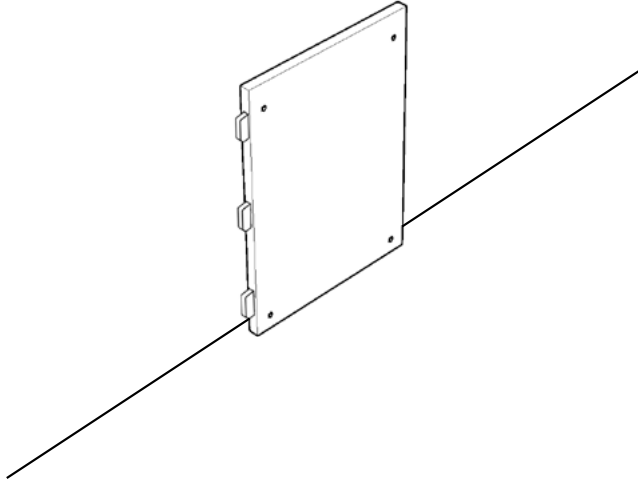

2 using the provided allen key (H) and JCB bolts (G x4), attach feet (F x4) to bottom (C). once all feet are securely attached, set the assembled base aside.

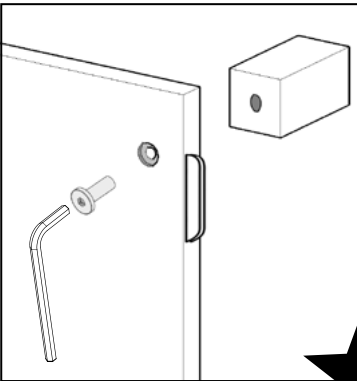

important!
be sure the JCB bolts are attached to the side of the bottom panel WITH the countersink holes.

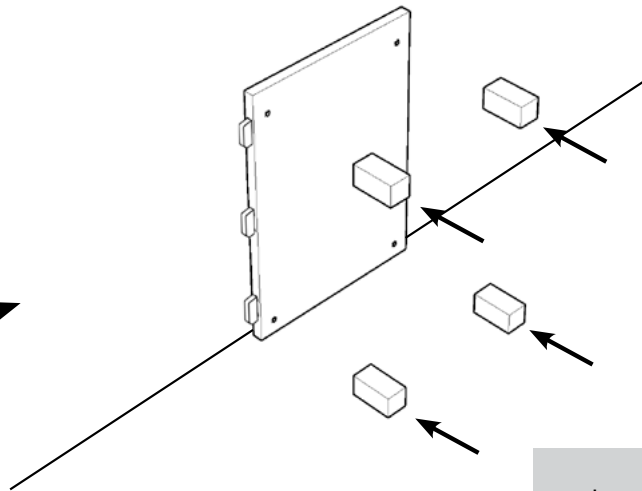

duc insider tip!
be sure the edges of the feet are square to the edges of the bottom panel before fully tightening the JCB bolts.

still confused? scan this code to watch the assembly video! →



3

lean R case exterior side (RC1) against a wall as shown.

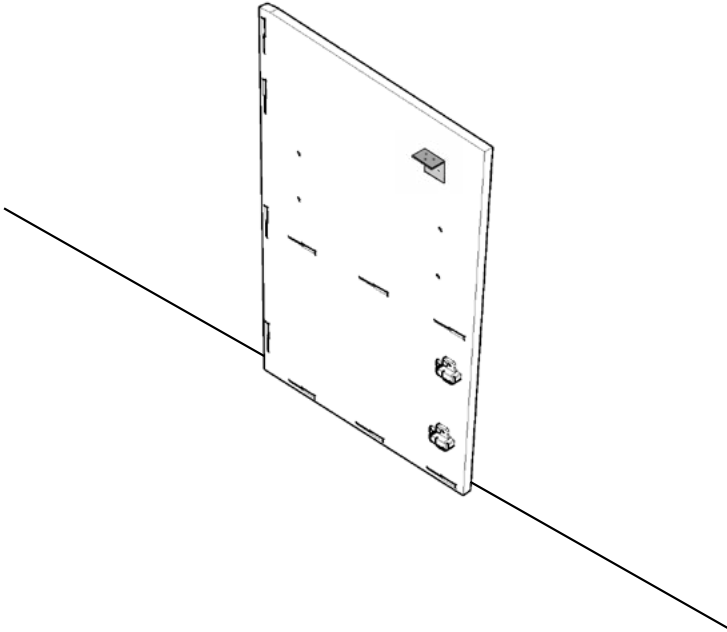

4

insert connectors on one back panel (E) into the 3 bottom slots on R case exterior side (RC1) as shown. push down at the connection to lock into place.

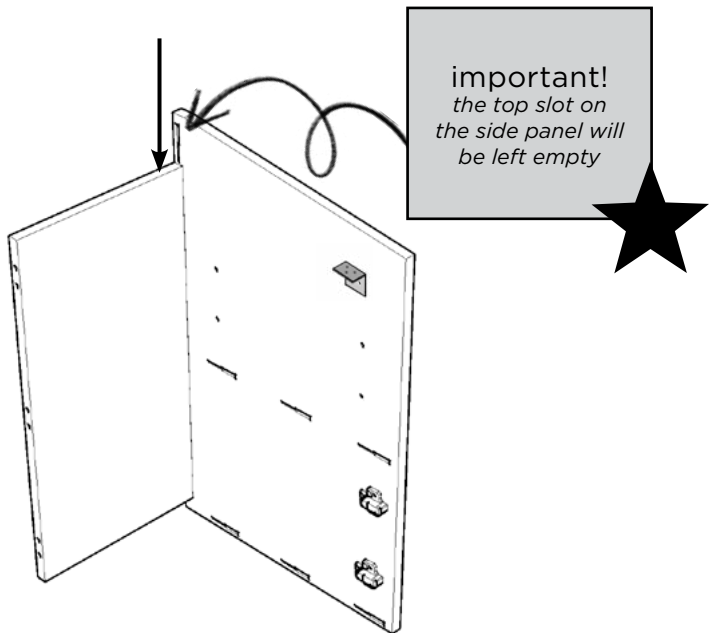

still confused? scan this code to watch the assembly video!



5

insert connectors on back panel (E) into slots on R case interior side (RC2). push down at the connection to lock into place.

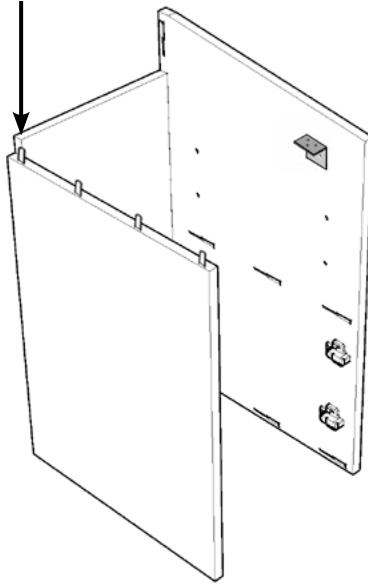

6a

have a friend gently flare R case exterior + interior sides (RC1 + RC2) outward as shown.

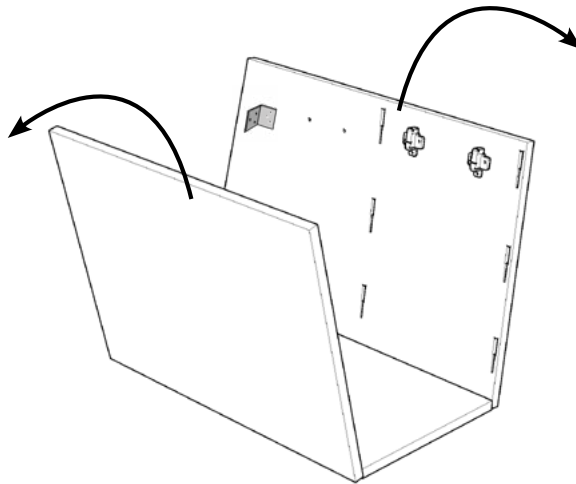

still confused? scan this code to watch the assembly video!



6b

with the sides flared outward, insert the connectors of one side of bottom (C) and R case fixed shelf (RC3) into slots on R case interior side (RC2).

important!
when inserting
the fixed shelf,
be sure the magnetic
catch hardware
is diagonal to the
hinge hardware on
the case interior

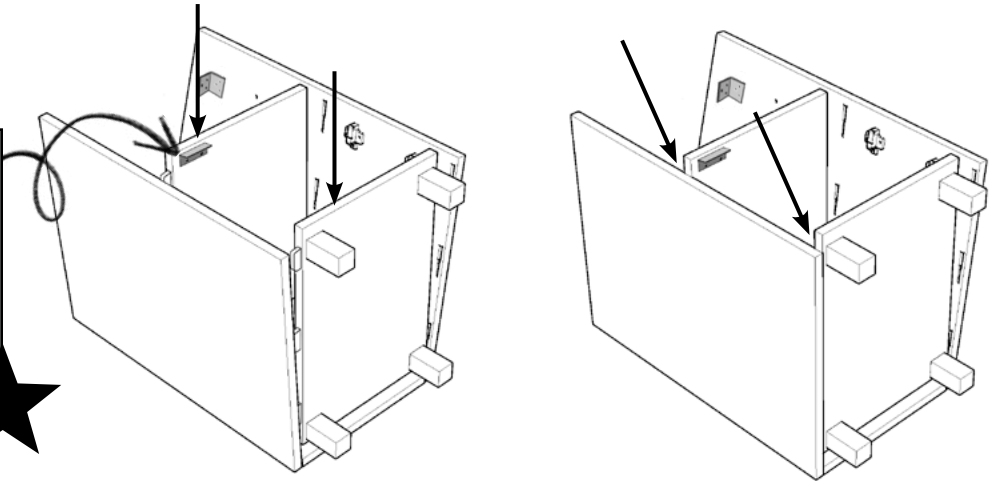

6c

insert remaining connectors of bottom (C) and R case fixed shelf (RC3) into slots on R case exterior side (RC1).

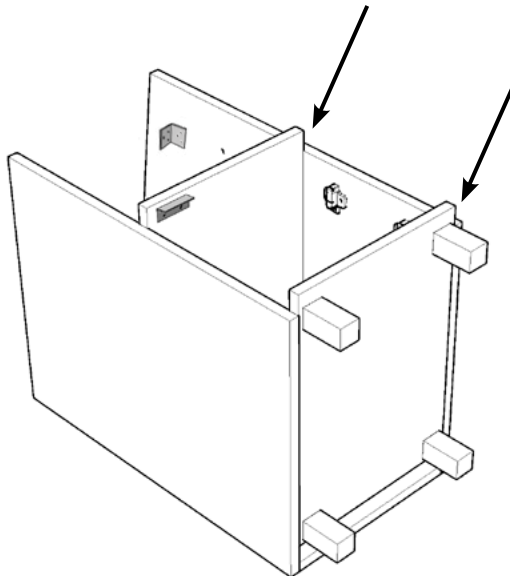

still confused? scan this code to watch the assembly video! →



6d

once all connectors and slots are lined up and case sides are back to square position, apply hammer cap (I) to the head of a household hammer and tap bottom (C) and fixed shelf (RC3) until there is no gap at the connection to back panel (E).

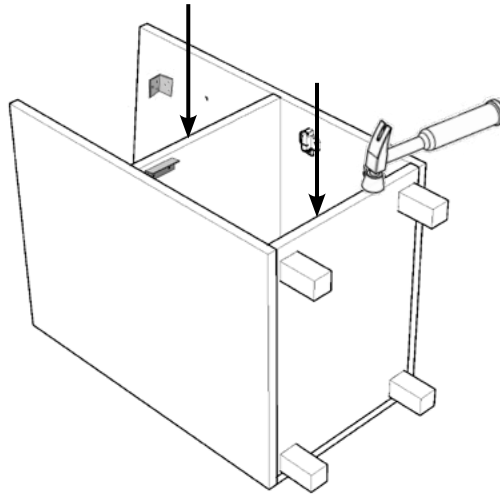

7

repeat steps 1-6 to create the second case from the remaining parts.

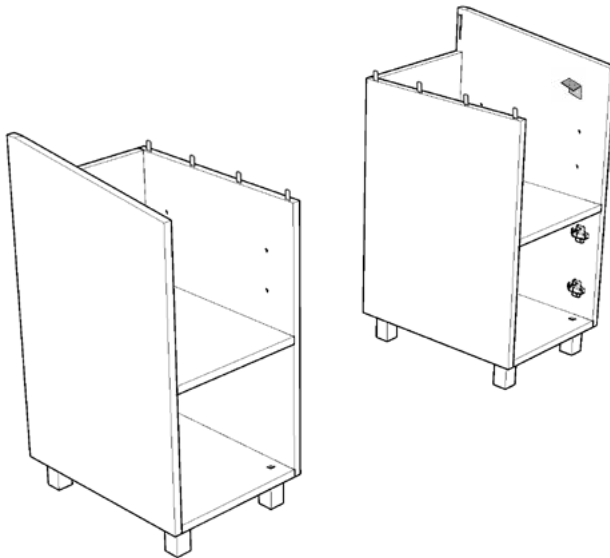

still confused? scan this code to watch the assembly video! →



8

lean desktop (B) against the wall with the slots facing out.

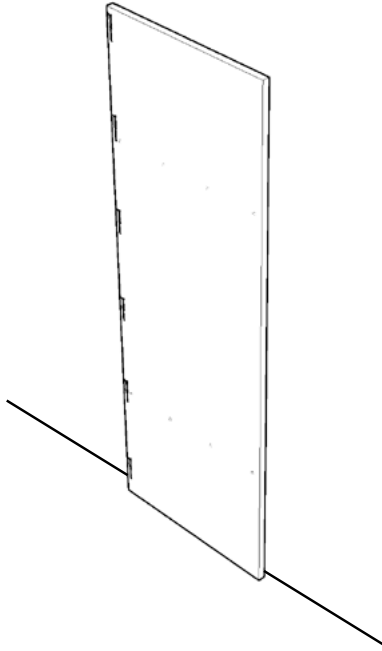

9

insert connectors on desktop back (A) into slots on desktop (B). use hammer with hammer cap (I) to lock into place.

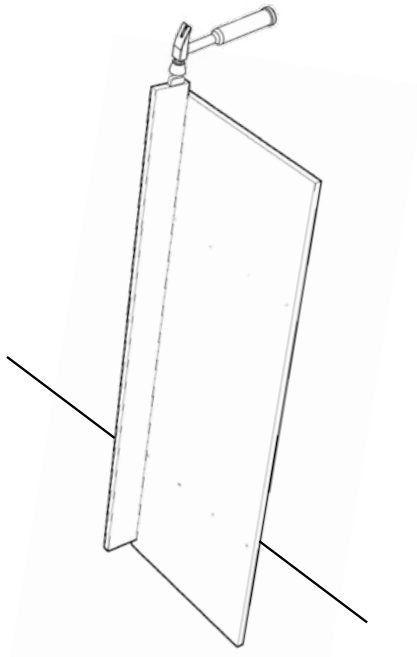

duc insider tip!
if you're having trouble locking in A to B all the way, tilt the partially assembled piece as shown so the connector on the desktop back is not touching the ground.

still confused? scan this code to watch the assembly video! →



11

place both cases in the location where the desk will be fully assembled with the cases spaced 60" apart.

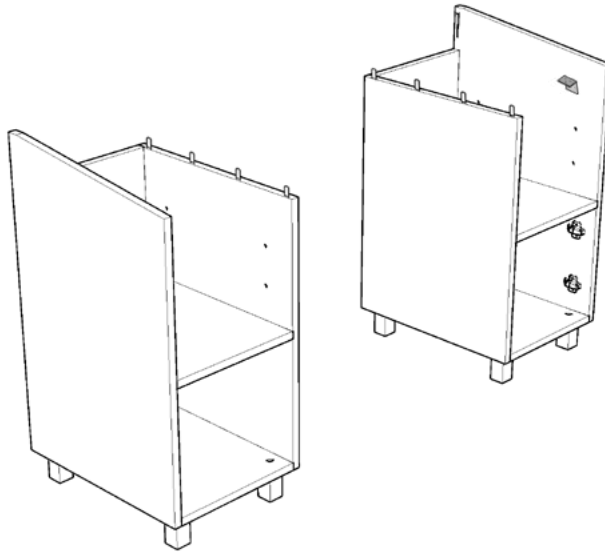

12

with a friend, lift assembled desktop (A + B) and first line up connectors on the desktop back (A) with the slots on both case side exteriors (RC1 + LC1). next, line up connectors on both case interior sides (RC2 + LC2) with the holes on the underside of desktop (B). use hammer with hammer cap (I) to lock into place.

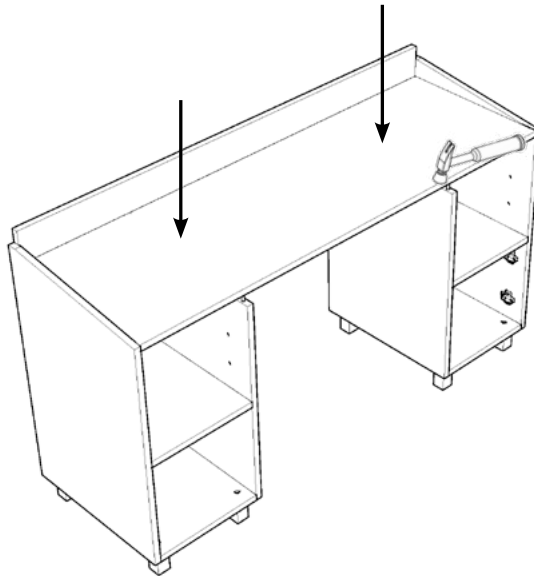

still confused? scan this code to watch the assembly video! →



13

use screws (J) and your phillips head screwdriver to secure desktop (B) to both case exterior sides (RC1 + LC1) using the attached brackets and pre-drilled holes.

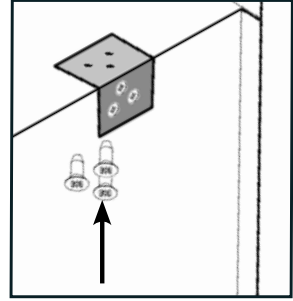
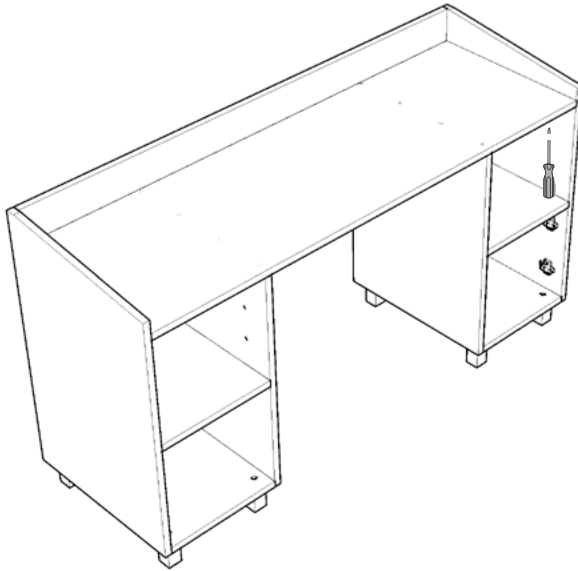

duc insider tip!
if you're handy and want to save a few secs, feel free to use a household drill.

14a

use your phillips screwdriver and screws (L), attach indi pull hardware (K) to the front of both doors (RC4 + LC4).

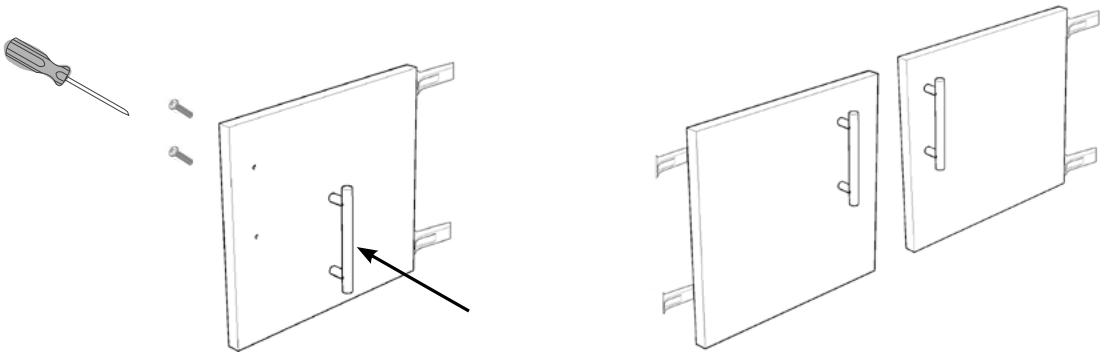

still confused? scan this code to watch the assembly video! →



14b

attach L door (LC4) to L case exterior side (LC1) by lining up the hardware and firmly pushing on it until it clicks into place.

important!

be sure the hardware is in extended position as shown. you will hear an audible click when the connection is made.

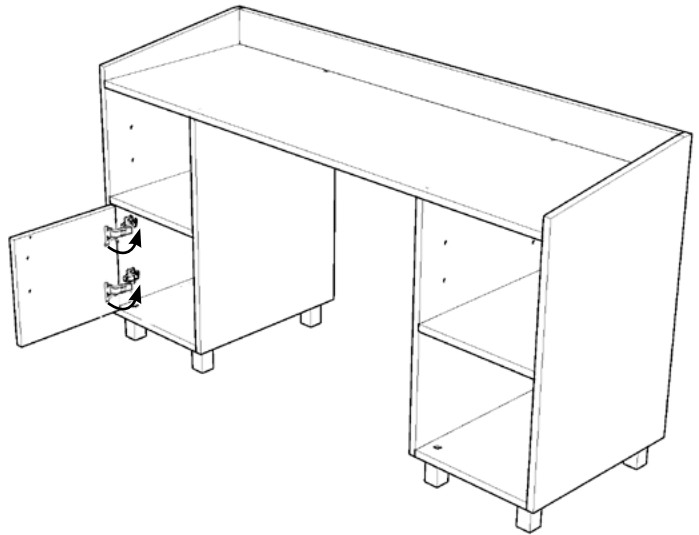
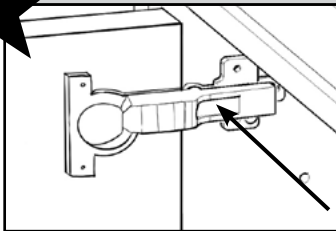

15

attach R door (RC4) to R case exterior side (RC1) using the same method.

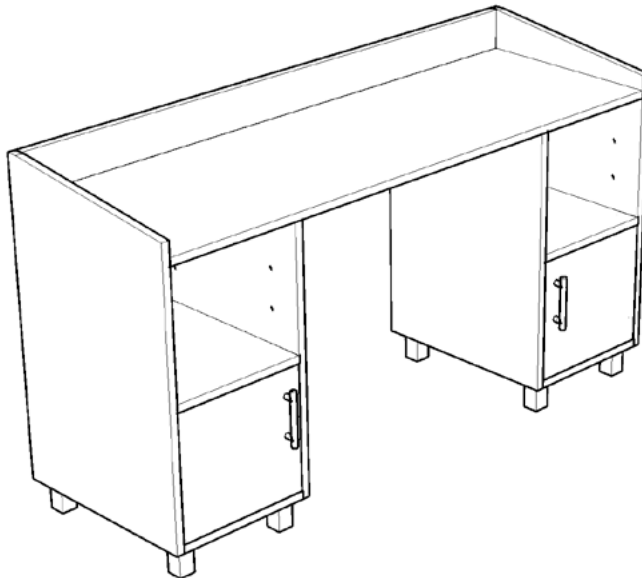

still confused? scan this code to watch the assembly video! →



16a

insert 4 shelf pins (M) into holes on both R case sides (RC1 + RC2) at desired height.

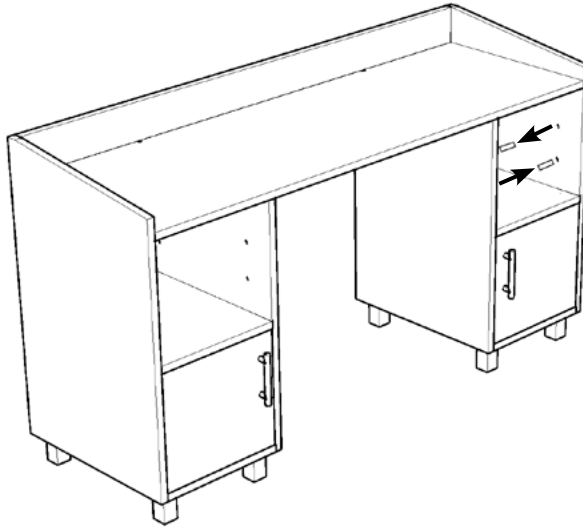

16b

place adjustable shelf (D) on top of 4 shelf pins (M) so it sits secure and level.

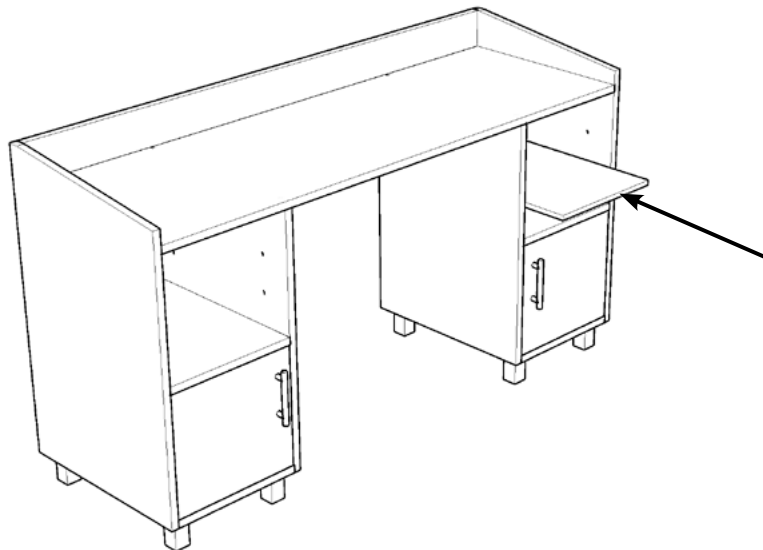

still confused? scan this code to watch the assembly video! →



17 use steps 16a + 16b to install the remaining adjustable shelf (D) on the L case.

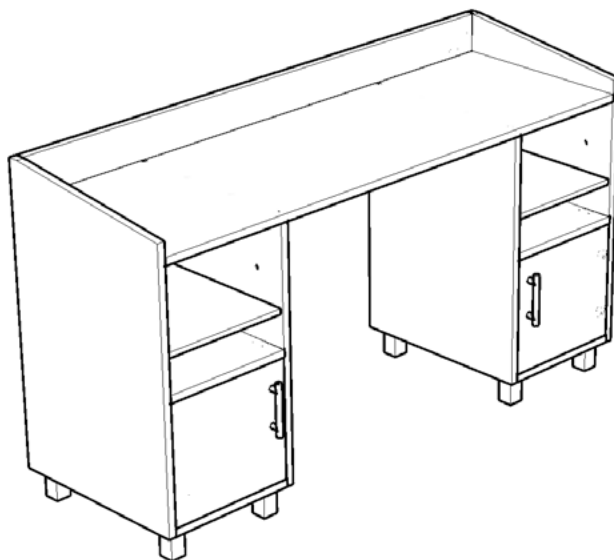

still confused? scan this code to watch the assembly video! →



bravo! you did it!

give yourself a pat on the back, take a bow,
or go house a pint of ice cream...we don't judge.

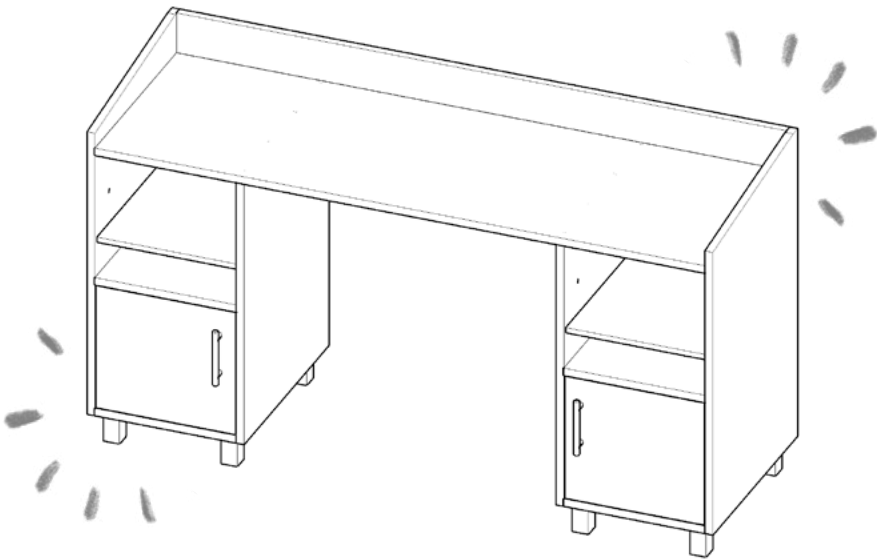

prefer to talk to a human instead? we're here for you!

contact our customer advocate team below:



212.226.1868



quack@ducducnyc.com



live chat at
ducducnyc.com



200 lexington, no. 701
ny, ny 10016