

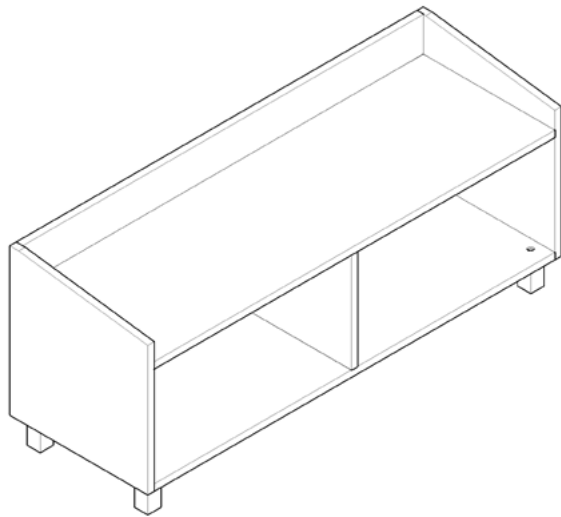

ASSEMBLY INSTRUCTIONS

indi bench

a how-to guide that won't leave you in tears



parenting is hard.
this is easy.

no really, it is.

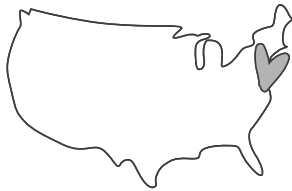

MADE HERE™



MADE WELL™

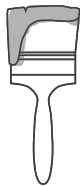

MADE SAFE



MADE SMART

want to watch this assembly IRL?

(acronym challenged? that means “in real life”.)

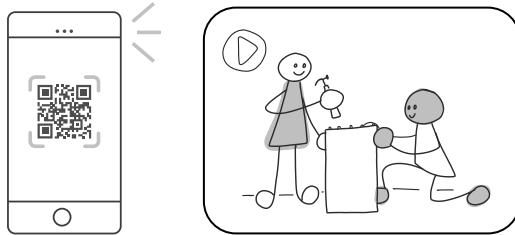

open the camera on your phone and place it over the QR code below to see our NYC studio dream team do all the heavy lifting (just kidding, there is none!)



or go to ducdcnyc.com/pages/assembly-instructions

**thank you for selecting a
studio duc product!**

please check contents against the components list in these instructions. also, please ensure there was no damage that may have occurred in shipping.

if any components are missing or you find any damage, please contact ducduc before continuing.

read all the instructions before use.

pay close attention to the safety warnings in these instructions.

a minimum of two people is required to safely assemble and move the bench. do not attempt to move this bench alone — dragging or sliding it across a floor may cause structural damage.

MAINTENANCE:

please remember to securely tighten all bolts and fasteners, and periodically check to make sure every component is properly and securely in place and all bolts and fasteners are tight.

CLEANING:

do not scratch or chip the finish. do not use abrasive chemicals for cleaning. clean with mild soap on a soft rag. rinse and dry thoroughly. if you ever refinish this furniture, be sure to use only a non-toxic finish specified for children's furniture.

KEEP INSTRUCTIONS FOR FUTURE USE

WHAT'S IN THE BOX:

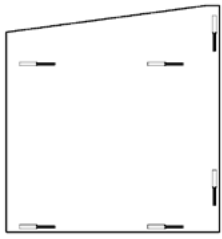

A1
L side

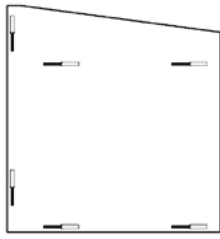

A2
R side

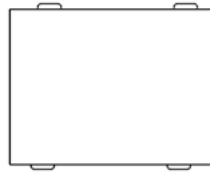

B
center partition

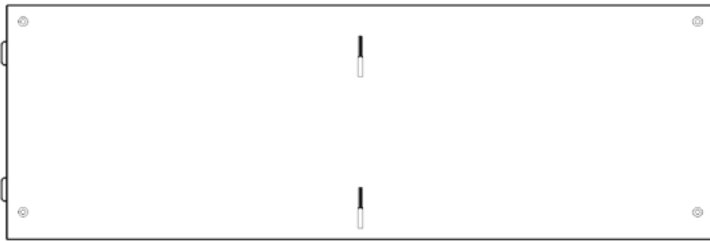

C
bottom



D
back

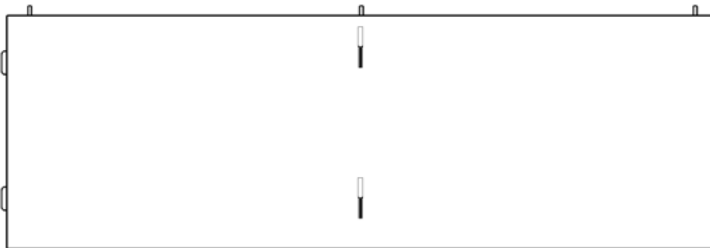

E
top



F (x4)
foot



G (x4)
JCB bolt (25mm)

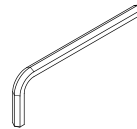

H
allen key (4mm)



I
hammer cap

WHAT YOU'LL NEED:



**household hammer or
rubber mallet**

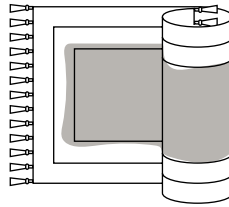

a soft surface to assemble on
*(like a rug or some of the corrugate
box your piece arrived in)*



2 people
plus a dog for moral support
(unless you're a cat person)



15 minutes
(or less)

1 lean bottom (C) against a wall as shown.

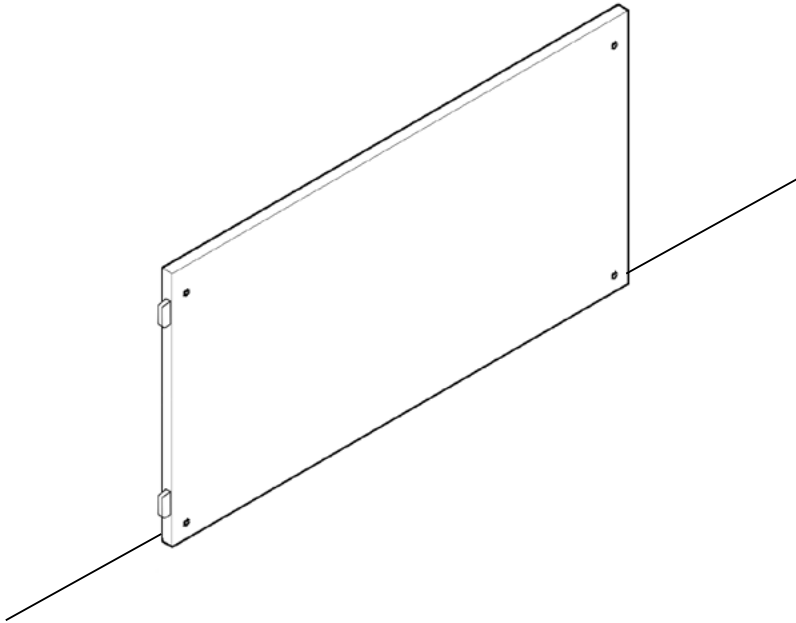

2 using the provided allen key (H) and JCB bolts (G), attach feet (F) to bottom (C). once all feet are securely attached, set the assembled base aside.

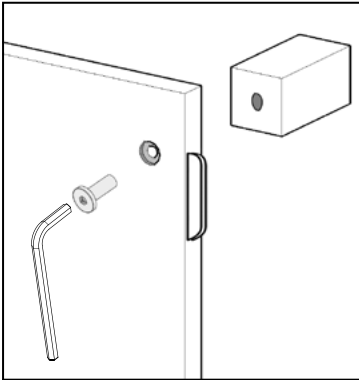

important!
be sure the JCB bolts are attached to the side of the bottom panel WITH the countersink holes.

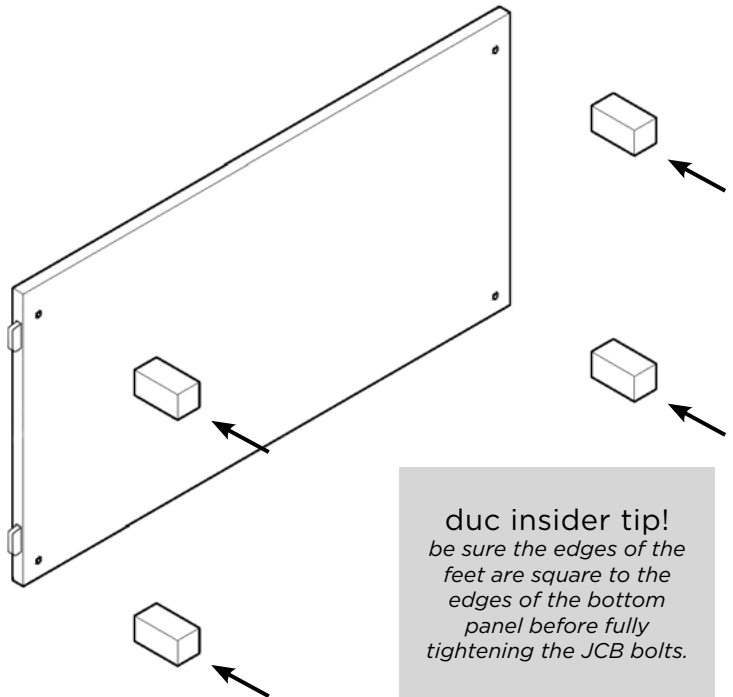

duc insider tip!
be sure the edges of the feet are square to the edges of the bottom panel before fully tightening the JCB bolts.

still confused? scan this code to watch the assembly video! →



3

flip the assembled base around so the feet are facing the wall. insert connectors on center partition (B) into slots on bottom (C) and push down to lock into place.

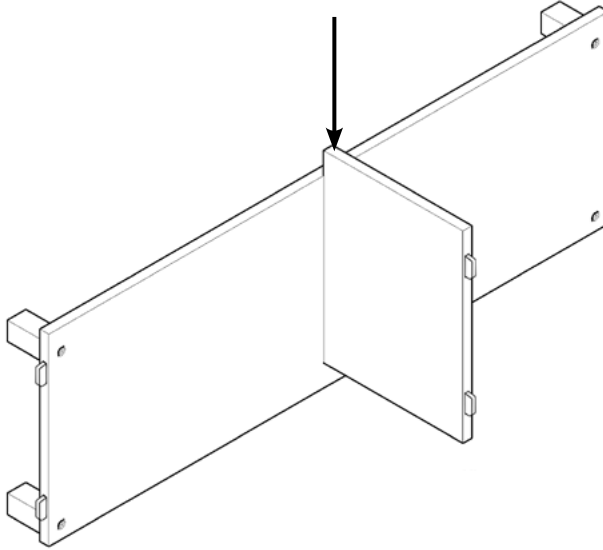

4

insert remaining connectors on center partition (B) into slots on top (E) and push down at the connection to lock into place. set assembled pieces aside for now.

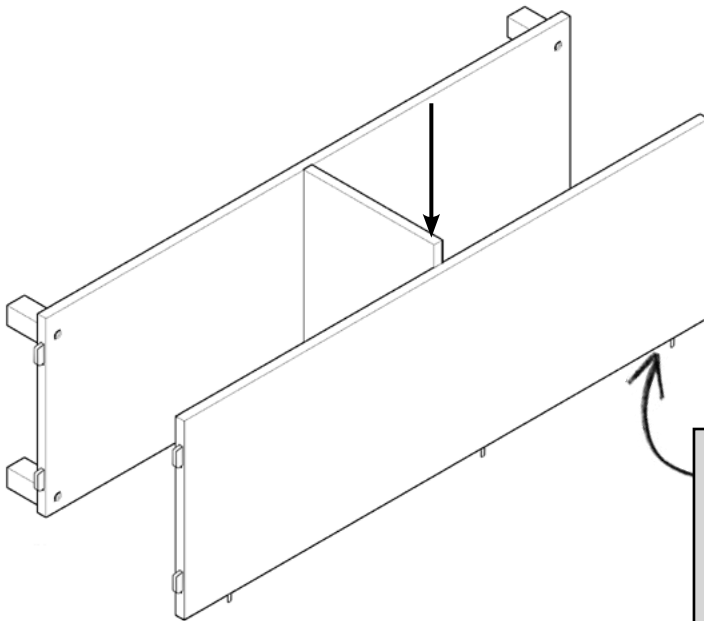

important!
before locking the top into place, be sure the 3 green connectors on the edge of the top are facing downward as shown here.



still confused? scan this code to watch the assembly video! →



5

lean L side (A1) against a wall as shown.

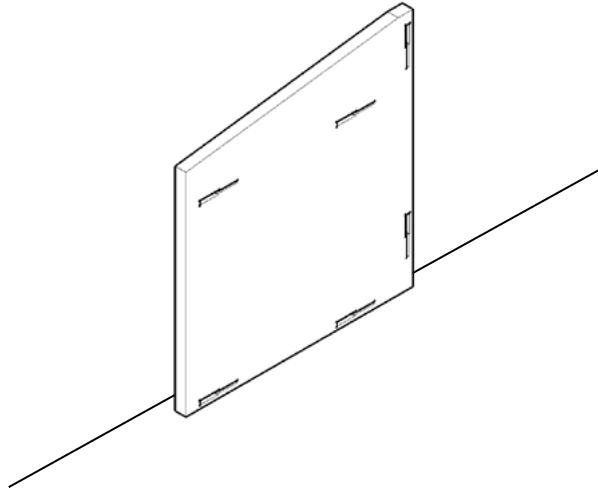

6

insert connectors on back (D) into slots on L side (A1). push down at the connection to lock into place.

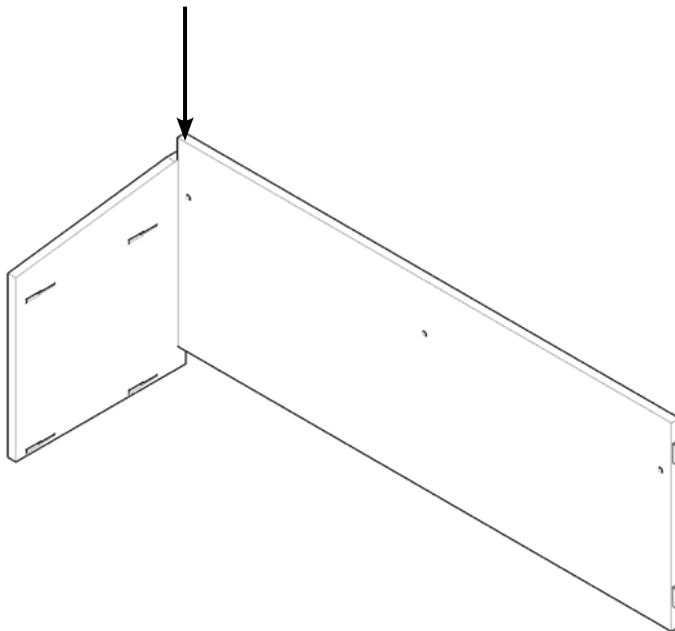

still confused? scan this code to watch the assembly video!



7

insert connectors on back (D) into slots on R side (A2). push down at the connection to lock into place.

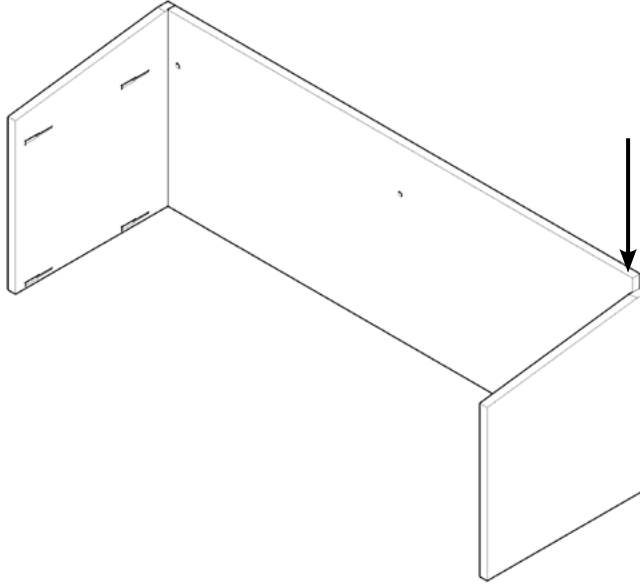

8a

gently lay the partially assembled case on its back and have a friend gently flare the sides (A1 + A2) outward as shown.

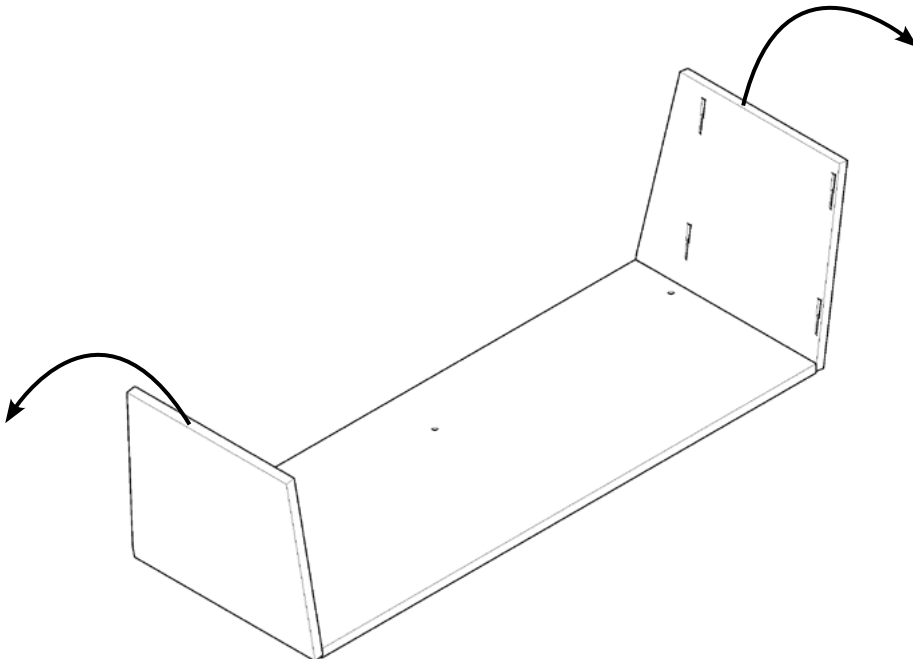

still confused? scan this code to watch the assembly video!



8b

with the sides flared outward, insert connectors of assembled base (C + F) and top (E) into slots on R side (A2).

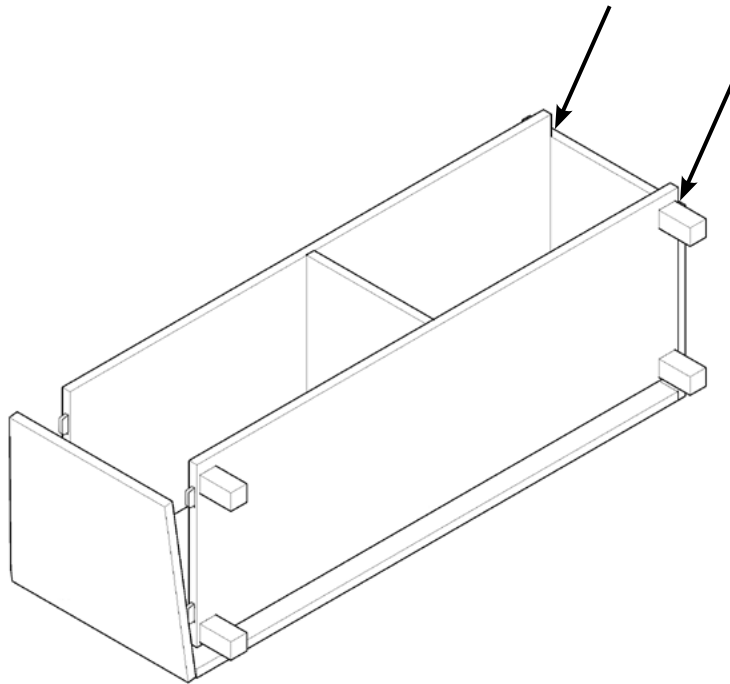
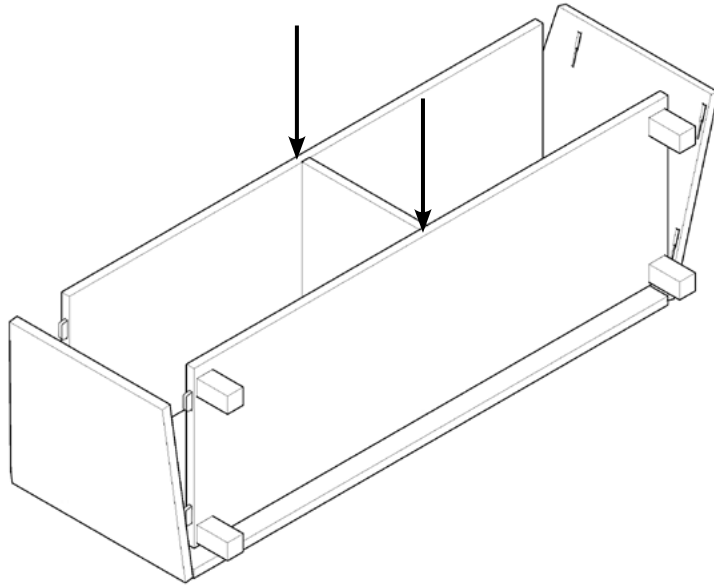

still confused? scan this code to watch the assembly video! →



8c

insert remaining connectors on assembled base (C + F) and top (E) into slots on L side panel (A2).

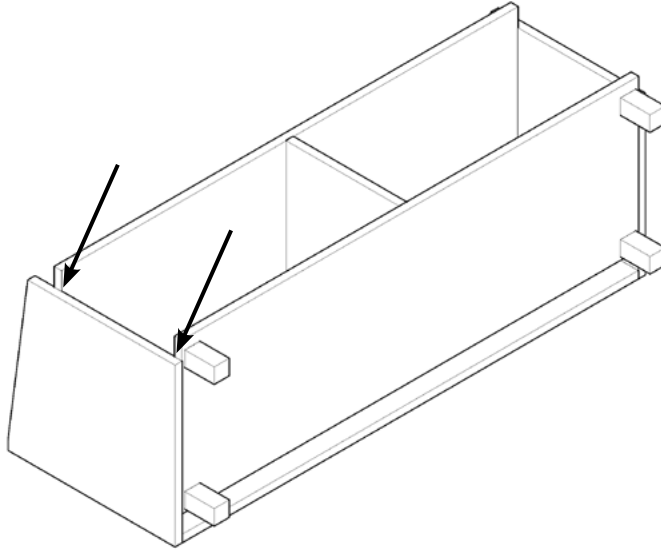

8d

once all connectors and slots are lined up and side panels are back to square position, apply hammer cap (I) to the head of a household hammer and tap bottom (C) and top (E) until there is no gap at the connection to back (D).

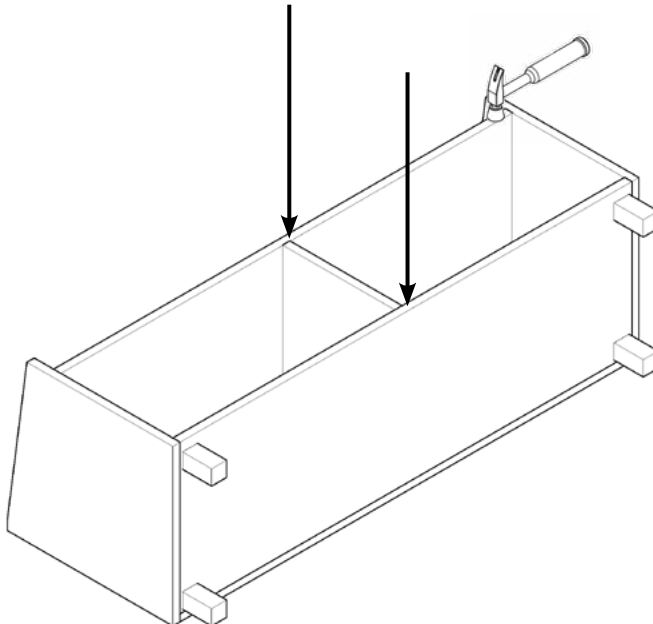

still confused? scan this code to watch the assembly video! →



9

rotate bench to upright position.

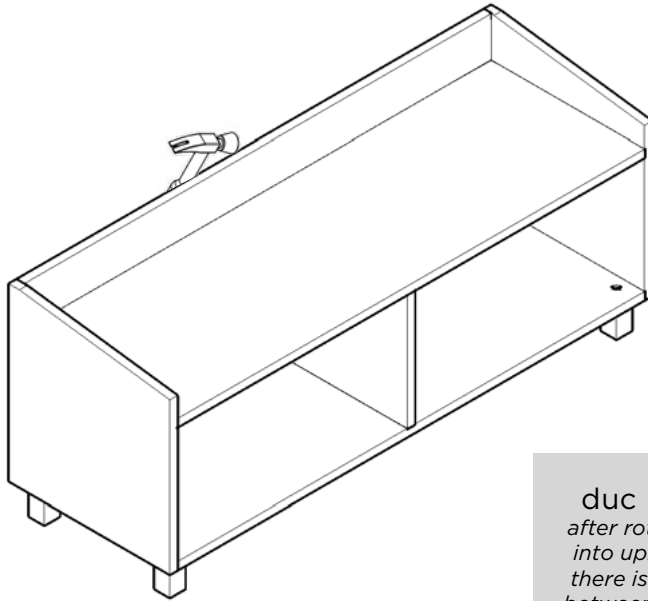

duc insider tip!
*after rotating the bench
into upright position, if
there is still a small gap
between the top and the
back, hammer the back
at each connection point
to fully secure into place.*

still confused? scan this code to watch the assembly video! →



huzzah! you did it!

give yourself a pat on the back, take a bow,
or go house a pint of ice cream...we don't judge.

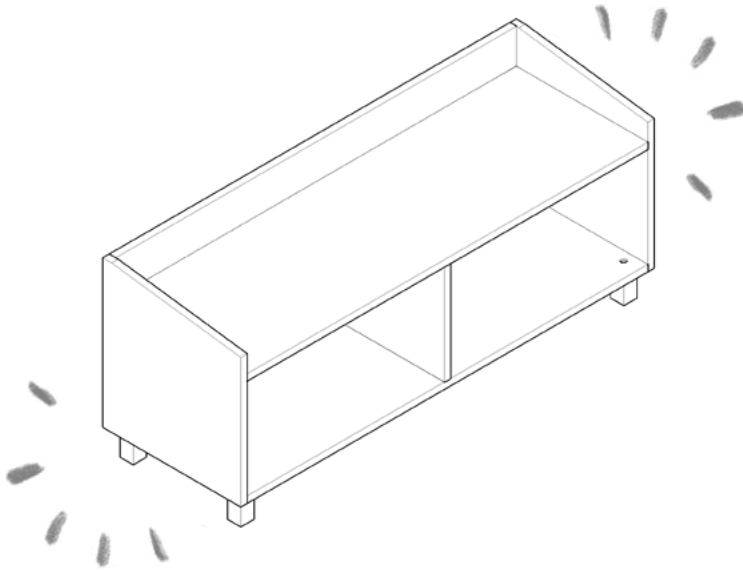

prefer to talk to a human instead? we're here for you!

contact our customer advocate team below:



212.226.1868



quack@ducducnyc.com



live chat at
ducducnyc.com



200 lexington, no. 701
ny, ny 10016