



Furniture Co.

Assembly Instructions

Poly Dining Chair



*Thank you for choosing **A&L Furniture Co.***

We hope that this piece brings you many years of enjoyment!

For help with assembling your furniture,
or if you have missing hardware, please email us at
helpalf@ibifax.com or call us at 814-349-8203

PARTS (included)

(A) Chair Seat (1)

(B) Back Rest(1)

(C) Front Legs (2)

(D) Leg Brace (1)



HARDWARE (included)

(a) 1 3/4" Bolts (8)

(b) 2 1/2" Screws (2)

(c) 1 1/2" Screws (2)

(d) Allen Wrench (1)

(e) Square Drive Bit (1)



TOOLS NEEDED

Screwgun

If your Dining Chair came with arms the following is also included:

PARTS (included)

(E) Right Arm (1)

(F) Left Arm (1)



HARDWARE (included)

(a) 1 3/4" Bolts (6)



STEP 1

Attach the back rest to the seat. Insert 1 3/4" bolts through the predrilled holes in the seat & screw into the metal inserts in the back rest. (See photos 1 & 2.) **Do not fully tighten any bolts until fully assembled.**

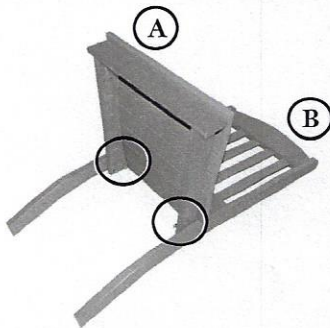

photo 1

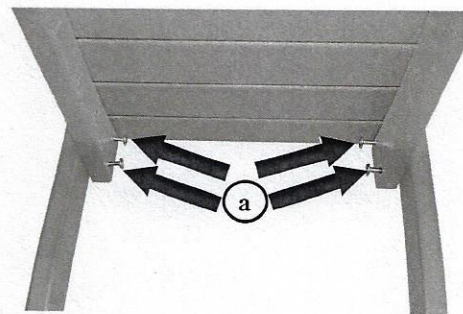

photo 2

STEP 2

Take the 2 front legs & line up the predrilled holes in the seat with the metal inserts in the legs. Insert the 1 3/4" bolts through the holes & screw into the metal inserts in the legs. (See photos 3 & 4.)

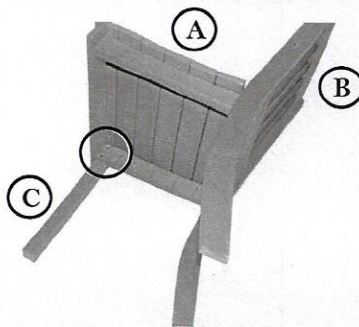

photo 3

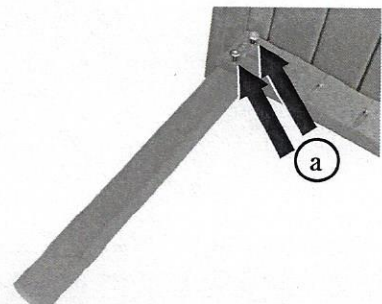

photo 4

STEP 3

Find the predrilled holes in the legs & line up with the leg brace. Insert the 2½" screws through the legs & into the frame using a screwgun. (See photos 5 & 6.)

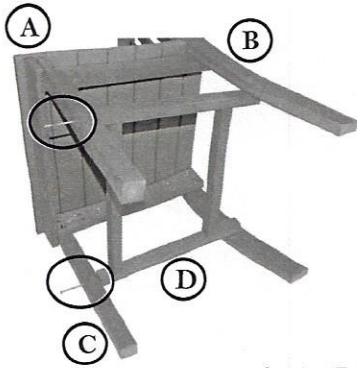

photo 5

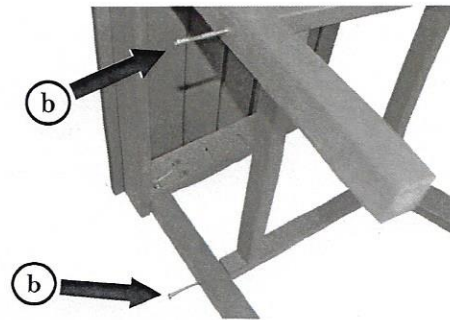

photo 6

STEP 4

Find the predrilled holes in the back legs & the brace. Insert the 1½" screws through the brace & into the back legs using a screwgun. (See photos 7 & 8.)

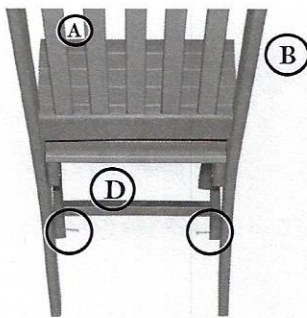

photo 7

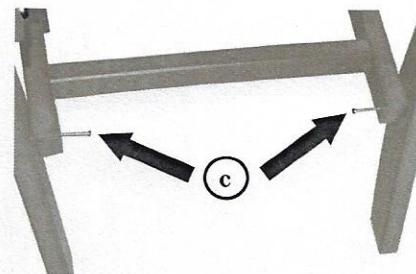

photo 8

If your chair came with arms, Step 5 is also needed.

STEP 5

Find the predrilled holes in the arms & seat, then align with the metal inserts in the arm & the back rest. Insert the 1¾" bolts through the holes & screw into the metal inserts. Tighten all the bolts with the Allen wrench. (See photos 9, 10 & 11.)

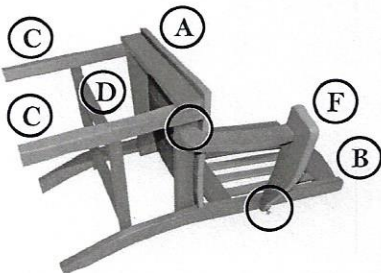

photo 9

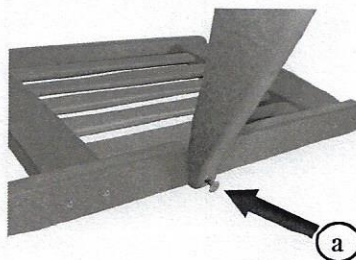

photo 10

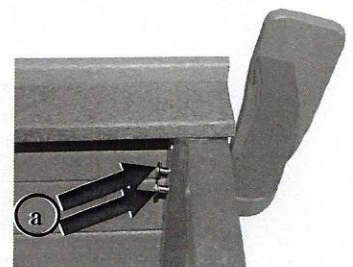

photo 11